

TECHNICAL MANUAL
DIRECT SUPPORT AND GENERAL SUPPORT
MAINTENANCE MANUAL
FOR
TRUCK, DUMP: 20-TON, 6X4
ON-OFF HIGHWAY, 71,000 GVW
(NSN 3805-00-192-7249
IHC MODEL F-5070 (CCE)

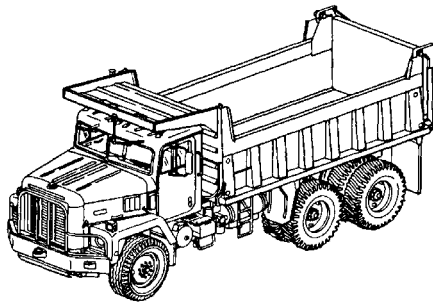

Troubleshooting Procedures	2-1
Cooling System	4-1
Electrical System	5-1
Transmission and Auxiliary Transmission	6-1
Axle	8-1
Differential	9-1
Brake System	10-1
Steering System	12-1
Suspension System	13-1
Body and Accessories	15-1
Power Take-off	16-1
Hydraulic System	17-1

This manual supersedes the Direct Support portion of TM 5-3805-254-14&P-1, dated 22 August 1980 and TM 5-3805-254-14&p-2, dated 12 June 1980.

Approved for public release; distribution is unlimited.

HEADQUARTERS, DEPARTMENT OF THE ARMY MARCH 1993

FOR INFORMATION ON FIRST AID, REFER TO FM 21-11.

WARNING

CARBON MONOXIDE EXHAUST GASES CAN KILL!

Carbon monoxide is a colorless, odorless, deadly poisonous gas which, when breathed, deprives the body of oxygen and causes suffocation. Exposure to air containing carbon monoxide produces symptoms of headache, dizziness, loss of muscular control, apparent drowsiness, and coma. Permanent brain damage or death can result from severe exposure.

Carbon monoxide occurs in exhaust fumes of internal combustion engines. Carbon monoxide can become dangerously concentrated under conditions of inadequate ventilation. The following precautions must be observed to ensure safety of personnel when engine of vehicle is operated for any purpose.

- (1) DO NOT operate engine of truck in enclosed areas.
- (2) DO NOT idle engine without ventilator blower operating and truck windows open.
- (3) BE ALERT at all times for exhaust odors.
- (4) BE ALERT for exhaust poisoning symptoms. They are:
 - Headache
 - Dizziness
 - Sleepiness
 - Loss of muscular control
- (5) If you see another person with exhaust poisoning symptoms:
 - Remove person from area.
 - Expose to fresh air.
 - Keep person warm.
 - Do not permit physical exercise.
 - Administer artificial respiration, if necessary.
 - Notify a medic.
- (6) BE AWARE: The field protective mask for chemical-biological-radiological (CBR) protection will not protect you from carbon monoxide poisoning.

The Best Defense Against Carbon Monoxide Poisoning Is Good Ventilation.

WARNING**ALCOHOL**

Do not smoke or allow open flames or sparks into areas where alcohol is being used. Failure to observe this precaution could cause death or serious injury to personnel.

WARNING**ASBESTOS HAZARD**

DO NOT handle brakeshoes, brakedrums, or other brake components unless area has been properly cleaned. There may be asbestos dust on these components which can be dangerous if you touch it or breathe it. Wear an approved filter mask and gloves. Never use compressed air or a dry brush to clean brake components. Dust may be removed using an industrial-type vacuum cleaner. Clean dust or mud away from brake components with water and a wet, soft brush or cloth. Failure to follow this warning may result in serious illness or death to personnel.

WARNING**BATTERY SAFETY**

Batteries can be dangerous if not handled properly. When working with batteries, use the following guidelines to ensure your safety:

- Electrolyte can cause severe skin burns.
- Wear rubber gloves and goggles when working with electrolyte.
- Do not get electrolyte on your skin.
- When removing battery cables, disconnect ground cables first.
- When installing battery cables, connect ground cables last.
- Ground cables must be disconnected prior to working on equipment where shorting of cables can occur.
- Incorrect cable installation is extremely dangerous.
- Always ensure that the correct cables go to the correct battery terminals.
- Keep all tools away from batteries.
- Do not smoke or have an open flame nearby while charging batteries.
- Remove all jewelry such as dog tags, rings, bracelets, etc.

WARNING**CLEANING AGENTS**

Dry cleaning solvent, P-D-680, is toxic and flammable. Always wear protective goggles and gloves, and use only in a well-ventilated area. Avoid contact with skin, eyes, and clothes, and DO NOT breathe vapors. DO NOT use near open flame or excessive heat. The solvent's flash point is 100°F-1380F (38°C-590C). If you become dizzy while using cleaning solvent, immediately get fresh air and medical help. If solvent contacts eyes, immediately wash your eyes and get medical aid.

WARNING**CLEANING AGENTS (Con't)**

Cleaning compound, trichlorotrifluoroethane, for electrical parts is toxic and flammable, and reacts violently with aluminum, titanium, barium, lithium, samarium, sodium, and potassium. Always wear protective goggles and rubber gloves, and use only in a well-ventilated area. DO NOT wear jewelry while using cleaning compound. Avoid contact with skin, eyes, and clothes, and DO NOT breathe vapors. Cleaning compound fumes or vapors can take the place of air and may become a cancer producing agent. DO NOT use near open flame or excessive heat. The compound's boiling point is 114°F (460C). If you become dizzy while using cleaning compound, immediately get fresh air and medical help. If compound contacts eyes, immediately wash your eyes with water and get medical aid.

WARNING**COMPRESSED AIR**

Compressed air used for cleaning or drying purposes, or for clearing restrictions, should never exceed 30 psi (207 kPa). Wear protective clothing (goggles/shield, gloves, etc.) and use caution to avoid injury to personnel.

WARNING**DIESEL FUEL**

Diesel fuel burns easily. Do not smoke or allow flames nearby. Disconnect batteries when working on fuel system. Failure to observe these precautions could cause serious Injury or death to personnel.

WARNING**EYE PROTECTION**

Wear eye protection when performing the following maintenance:

- Working under vehicle.
- Cleaning with wire brushes.
- Striking metal parts with hammer or chisel.
- Welding or heating vehicle components.
- Using chisel or drill.
- Using compressed air.

WARNING**FUEL TANK**

No welding, grinding, or use of heat producing devices is permitted near fuel tank unless fuel tank has been cleaned and purged of all flammable liquids and vapors. Failure to observe these precautions could cause serious Injury to personnel.

WARNING

HANDLING HEAVY COMPONENTS

Due to excessive weight, assistance will be needed to prevent personal injury when lifting heavy parts.

WARNING

HYDRAULIC LINES

Do not attempt to disconnect hydraulic lines and fittings while engine is running or before hydraulic system pressure has been released. When engine is running, hydraulic system is under pressure. Hydraulic system pressure should be 0 psi (0 kPa) before lines are disconnected. A line or fitting disconnected under pressure will explode with great force and can cause injury to personnel.

WARNING

NBC HAZARD

If NBC exposure is suspected, all engine air cleaner air filter media should be handled by personnel wearing protective equipment. Consult your NBC Officer or NBC NCO for appropriate handling or disposal procedures.

TECHNICAL MANUAL

TM 5-3805-254-34*

HEADQUARTERS
DEPARTMENT OF THE ARMY
Washington D.C., 1 March 1993

**DIRECT SUPPORT AND GENERAL SUPPORT
MAINTENANCE MANUAL
FOR
TRUCK, DUMP: 20-TON, 6 X 4
ON-OFF HIGHWAY, 71,000 GVW
(NSN 3805-00-192-7249)

IHC MODEL F-5070**

REPORTING ERRORS AND RECOMMENDING IMPROVEMENTS

You can help improve this manual. If you find any mistakes or if you know of a way to improve the procedures, please let us know. Mail your letter, DA Form 2028 (Recommended Changes to Publications and Blank Forms), or DA Form 2028-2, located in the back of this manual, direct to: Commander, U.S. Army Tank-Automotive Command, ATTN: AMSTA-MB, Warren, MI 48397-5000. A reply will be furnished to you.

TABLE OF CONTENTS

	Page
How To Use This Manual	iii
CHAPTER 1. INTRODUCTION	
Section I. General Information	1-1
Section II. Equipment Description and Data	1-2
Section III. Repair Parts; Special Tools; Test, Measurement, and Diagnostic Equipment (CTMDE); and Support Equipment	1-3
Section IV. General Maintenance Instructions	1-4
CHAPTER 2. TROUBLESHOOTING PROCEDURES	2-1
CHAPTER 3. ENGINE MAINTENANCE	3-1
CHAPTER 4. COOLING SYSTEM MAINTENANCE	4-1
CHAPTER 5. ELECTRICAL SYSTEM MAINTENANCE	5-1

Approved for public release; distribution is unlimited.

• This manual supersedes the Direct Support/General Support portion of TM 5-3805-254-14&P-1, dated 22 August 1980 and TM 5-3805-254-14&P-2, dated 12 June 1980.

TABLE OF CONTENTS (Con't)

	Page
CHAPTER 6. TRANSMISSION AND AUXILIARY TRANSMISSION MAINTENANCE	6-1
CHAPTER 7. PROPELLER SHAFT AND UNIVERSAL JOINT MAINTENANCE.....	7-1
CHAPTER 8. AXLE MAINTENANCE	8-1
CHAPTER 9. DIFFERENTIAL MAINTENANCE	9-1
CHAPTER 10. BRAKE SYSTEM MAINTENANCE	10-1
CHAPTER 11. WHEEL, TIRE, HUB, AND BRAKEDRUMS MAINTENANCE.....	11-1
CHAPTER 12. STEERING SYSTEM MAINTENANCE	12-1
CHAPTER 13. SUSPENSION SYSTEM MAINTENANCE	13-1
CHAPTER 14. FRAME MAINTENANCE.....	14-1
CHAPTER 15. BODY AND ACCESSORIES MAINTENANCE	15-1
CHAPTER 16. POWER TAKE-OFF MAINTENANCE.....	16-1
CHAPTER 17. HYDRAULIC SYSTEM MAINTENANCE.....	17-1
APPENDIX A. REFERENCES.....	A-1
APPENDIX B. EXPENDABLE/DURABLE SUPPLIES AND MATERIALS LIST.....	B-1
APPENDIX C. ILLUSTRATED LIST OF MANUFACTURED ITEMS.....	C-1
APPENDIX D. TORQUE LIMITS.....	D-1
INDEX	Index 1
FO-1. Wiring Diagram	FP-1

HOW TO USE THIS MANUAL

This manual is designed to help maintain the IHC Model F-5070 (CCE) dump truck. It describes in detail the Direct Support and General Support Maintenance prescribed by the Maintenance Allocation Chart (see TM 53805-254-20) and the Source, Maintenance, and Recoverability (SMR) Codes (see TM 5-3805-254-34P).

FEATURES OF THIS MANUAL:

- Bleed-to-edge Indicators on the cover and on the edge of the applicable manual pages provide quick access to chapters and sections most often used.
- A table of contents is provided for all chapters and sections.
- WARNINGS, CAUTIONS, and NOTES, subject headings, and other important information are highlighted in BOLD print as a visual aid.
- Statements and words of particular importance are printed in capital letters to create emphasis.
- Instructions are located together with illustrations that show the specific task on which the technician is working.
- Equipment locator illustrations are provided throughout the maintenance procedures. These illustrations are for use in locating components and assemblies of the overall equipment.
- An alphabetical index is provided at the end of the manual to assist in locating information not readily found in the table of contents.
- Technical instructions include metric units in addition to standard units. A metric conversion chart is provided on the inside back cover.

FOLLOW THESE GUIDELINES WHEN YOU USE THE MANUAL:

- Read through this manual and become familiar with its contents before proceeding to specific maintenance tasks.
- A Warning Summary is provided at the beginning of this manual and should be read before performing any maintenance tasks.
- In the actual maintenance tasks, follow all WARNINGS, CAUTIONS, and NOTES. These are given immediately preceding the procedural steps to which they apply. If these instructions are not followed or care is not taken, injury to personnel or equipment damage may result.
- Within a chapter, section, or paragraph, headings are used to help group the material and assist in quickly finding tasks. Read all preliminary information found at the beginning of each task. After completing a task, ALWAYS perform the follow-on maintenance at the end of the task.

**CHAPTER 1
INTRODUCTION**

Section I. GENERAL INFORMATION

Paragraph Number	Paragraph Title	Page Number
1-1	Scope	1-1
1-2	Maintenance Forms, Records, and Reports	1-1
1-3	Destruction of Army Materiel to Prevent Enemy Use.....	1-1
1-4	Reporting Equipment Improvement Recommendations (EIR s)	1-1

1-1. SCOPE.

This manual contains instructions for the performance of Direct and General Support Maintenance for the 20-Ton Dump Truck, IHC Model F-5070.

1-2. MAINTENANCE FORMS, RECORDS, AND REPORTS.

Department of the Army forms and procedures used for equipment maintenance will be those prescribed by DA Pam 738-750, The Army Maintenance Management System (TAMMS).

1-3. DESTRUCTION OF ARMY MATERIEL TO PREVENT ENEMY USE.

For information on destruction of Army materiel to prevent enemy use, refer to TM 750-244-6.

1-4. REPORTING EQUIPMENT IMPROVEMENT RECOMMENDATIONS (EIRs).

If your truck needs improvement, let us know. Send us an EIR. You, the user, are the only one who can tell us what you don't like about your equipment. Let us know why you don't like the design. Put it on an SF Form 368 (Product Quality Deficiency Report). Mail it to us at: Commander, U.S. Army Tank-Automotive Command, Attn: AMSTA-MP, Warren, MI 48397-5000. We'll send you a reply.

Section II. EQUIPMENT DESCRIPTION AND DATA

Paragraph Number	Paragraph Title	Page Number
1-5	Location and Description of Major Components	1-2
1-6	Equipment Data.....	1-2

1-5. LOCATION AND DESCRIPTION OF MAJOR COMPONENTS.

Refer to TM 5-3805-254-10 and TM 5-3805-254-20 for location and description of major components.

1-6. EQUIPMENT DATA.

Refer to TM 5-3805-254-10 for performance data and capacities information. Refer to TM 5-3805-254-20 for principles of operation.

**Section III. REPAIR PARTS; SPECIAL TOOLS; TEST,
MEASUREMENT, AND DIAGNOSTIC EQUIPMENT
(TMDE); AND SUPPORT EQUIPMENT**

Paragraph Number	Paragraph Title	Page Number
1-7	Common Tools	1-3
1-8	Special Tools.....	1-3
1-9	Repair Parts	1-3

1-7. COMMON TOOLS.

For authorized common tools and test equipment, refer to the Modified Table of Organization and Equipment (MTOE) applicable to your dump truck.

1-8. SPECIAL TOOLS.

Refer to TM 5-3805-254-34P for information on special tools and support equipment to support the dump truck.

1-9. REPAIR PARTS.

Refer to TM 5-3805-254-34P for information on repair parts to support the maintenance of the dump truck.

Section IV. GENERAL MAINTENANCE INSTRUCTIONS

Paragraph Number	Paragraph Title	Page Number
1-10	General.....	1-4
1-11	Work Safety.....	1-5
1-12	Cleaning Instructions.....	1-5
1-13	Preservation of Parts.....	1-6
1-14	Painting	1-6
1-15	Inspection Instructions	1-6
1-16	Tagging Parts.....	1-7
1-17	Electrical Ground Points.....	1-7
1-18	Lines and Ports	1-8
1-19	Antiseizing Tape.....	1-8
1-20	Tubes and Compression Fittings	1-9
1-21	Lockwire	1-9
1-22	Fluid Disposal.....	1-10
1-23	Transmission.....	1-10

1-10. GENERAL.

a. These general maintenance instructions contain general shop practices and specific procedures you must be familiar with to properly maintain your dump truck. You should read and understand these practices and procedures before performing any Direct Support and General Support Maintenance procedures.

b. Before beginning a task, find out how much repair, modification, or replacement is needed to fix the equipment. Sometimes the reason for equipment failure can be seen right away and complete teardown is not necessary. Disassemble equipment only as far as necessary to repair or replace damaged parts.

c. In some cases, a part may be damaged by removal. If the part appears to be good and other parts behind it are not defective, leave it on and continue with the procedure. Here are a few simple rules:

(1) Do not remove dowel pins or studs unless loose, bent, broken, or otherwise damaged.

(2) Do not remove bearings or bushings unless damaged. If you need to remove them to access parts behind, pull bearings and bushings out carefully.

(3) Replace all gaskets, lockwashers, seals, cotter pins, and preformed packings.

d. The following "Initial Setup" information applies to all procedures:

(1) Resources are not listed unless they apply to the procedure.

(2) "Personnel Required" is listed only if more than one mechanic is required to complete the task.

e. All tags and forms attached to equipment must be checked to learn the reason for removal of equipment from service. Modification Work Orders (MWO) and Technical Bulletins (TB) must also be checked for equipment changes and updates.

1-11. WORK SAFETY.

- a. Before beginning a procedure, think about the safety risks and hazards to yourself and others. Wear protective gear such as safety goggles or lenses, safety shoes, rubber apron, or gloves.
- b. Immediately clean up spilled fluids to avoid slipping.
- c. When lifting heavy parts, have someone help you. Ensure that lifting/jacking tool is working properly, that it meets weight requirement of the part being lifted, and that it is securely fastened to the part.
- d. Always use power tools carefully.
- e. Observe all WARNINGS and CAUTIONS.

1-12. CLEANING INSTRUCTIONS.

WARNING

Improper cleaning methods and use of unauthorized cleaning liquids or solvents can injure personnel and damage equipment. To prevent this, refer to TM 9-247 for further instructions.

- a. **General.** Cleaning Instructions will be the same for the majority of parts and components which make up the dump truck. The following applies to all cleaning operations:
 - (1) Clean all parts before inspection, after repair, and before assembly.
 - (2) Keep hands free of grease which can collect dust, dirt, and grit.
 - (3) After cleaning, all parts should be covered or wrapped to protect them from dust and dirt. Parts that are subject to rust should be lightly oiled.
- b. **Steam Cleaning.**
 - (1) Before steam cleaning dump truck, protect all electrical equipment which could be damaged by steam or moisture.

WARNING

Avoid contact with live steam. Live steam can burn skin, cause blindness, and cause other serious injury. Be sure to wear protective apron, gloves, and safety goggles when using live steam.

- (2) Place disassembled parts in a suitable container to steam clean. Parts that are subject to rust should be dried and lightly oiled after cleaning.
- c. Castings, Forgings, and Machined Metal Parts.

WARNING

Dry cleaning solvent, P-D-680, is toxic and flammable. Always wear protective goggles and gloves, and use only in a well-ventilated area. Avoid contact with skin, eyes, and clothes, and DO NOT breathe vapors. DO NOT use near open flame or excessive heat. The solvent's flash point is 100°F-1380F (38°C-590C). If you become dizzy while using cleaning solvent, immediately get fresh air and medical help. If solvent contacts eyes, immediately wash your eyes and get medical aid.

- (1) Clean inner and outer surfaces with dry cleaning solvent (Item 23, Appendix B).

1-12. CLEANING INSTRUCTIONS (Con't).

- (2) Remove grease and accumulated deposits with a scrub brush (item 3, Appendix B).

WARNING

Compressed air used for cleaning or drying purposes, or for clearing restrictions, should never exceed 30 psi (207 kPa). Wear protective clothing (goggles/shield, gloves, etc.) and use caution to avoid injury to personnel.

- (3) Clear all threaded holes with compressed air to remove dirt and cleaning fluids.

CAUTION

Do not wash oil seals, electrical cables, and flexible hoses with dry cleaning solvent or mineral spirits. Serious damage or destruction of material will result.

- d. **Oil Seals, Electrical Cables, and Flexible Hoses.** Wash oil seals, electrical cables, and flexible hoses with a solution of detergent (item 6, Appendix B) and water and wipe dry.
- e. **Bearings.** Clean bearings in accordance with TM 9-214.
- f. **General Cleaning Covered By Other Manuals.**
- (1) TB 43-0212, *Purging, Cleaning and Coating Interior Ferrous and Terne Sheet Vehicle Fuel Tanks.*
- (2) TB 750-1047, *Elimination of Combustibles from Interiors of Metal or Plastic Gasoline and Diesel Fuel Tanks.*
- (3) TM 9-247, *Materials Used for Cleaning, Preserving, Abrading, and Cementing Ordnance Materiel and Related Items, Including Chemicals.*

1-13. PRESERVATION OF PARTS.

Unpainted metal parts that will not be installed immediately after cleaning may be covered with a thin coat of engine oil (Item 14, Appendix B).

1-14. PAINTING.

- a. On painted areas where paint has been removed, paint in accordance with procedures outlined in TM 43-0139 and TB 43-0209.
- b. For camouflage painting instructions refer to FM 5-20.

1-15. INSPECTION INSTRUCTIONS.

NOTE

All damaged areas should be marked for repair or replacement.

- a. All components and parts must be carefully checked to determine if they are serviceable for use, can be repaired, or must be scrapped.

1-15. INSPECTION INSTRUCTIONS (Con't).

- b. Inspect drilled and tapped (threaded) holes for the following:
 - (1) Wear, distortion, cracks, and any other damage in or around holes.
 - (2) Threaded areas for wear distortion (stretching) and evidence of cross-threading.
- c. Inspect metal lines, flexible lines (hoses), and metal fittings and connectors for the following:
 - (1) Metal lines for sharp kinks, cracks, bad bends, and dents.
 - (2) Flexible lines for fraying, evidence of leakage, and loose metal fittings or connectors.
 - (3) Metal fittings and connectors for thread damage and worn or rounded hex heads.
- d. Inspect castings, forgings, and machined metal parts for the following:
 - (1) Machined surfaces for nicks, burrs, raised metal wear, and other damage.
 - (2) Inner and outer surfaces for breaks and cracks.
- e. Inspect bearings in accordance with TM 9-214.

1-16. TAGGING PARTS.

- a. Use marker tags (item 25, Appendix B) to identify all electrical wires, hydraulic, fuel, oil, and coolant lines, and any other parts which may be hard to identify or replace later. Fasten tags to parts during removal by wrapping wire fasteners around or through parts and twisting ends together. Position tags to be out of the way during cleaning, inspection, and repair. Mark tags with a pencil, pen, or marker.
- b. Whenever possible, identify electrical wires with number of terminal or wire to which it connects. If no markings can be found, tag both wires or wire and terminal, and use same identifying mark for both. If you cannot tag wire because it must fit through small hole or you cannot reach it, write down description of wire and the point to which it connects or draw a simple diagram on paper. Be sure to write down enough information so you will be able to connect wires properly during assembly. If you need to identify a loose wire, look for identifying numbers near end of wire, stamped on a permanent metal tag. Compare this number to wire numbers on appropriate electrical schematic.
- c. Identify hydraulic, fuel, oil, and coolant lines whenever you are taking off more than one line at the same time. Mark tags with points to which lines and hoses must be connected. If it is not obvious which end of a line goes where, tag each end of line.
- d. Identify and tag other parts as required by name and installed location.

1-17. ELECTRICAL GROUND POINTS.

Many electrical problems are the result of poor ground connections. You can ensure that ground connections are good by performing the following steps:

WARNING

Although battery disconnect switch must be on and battery ground cable connected to test electrical circuit voltage, turn off battery disconnect switch or disconnect battery ground cable before doing resistance tests or replacing parts. This will prevent shock and damage to parts and equipment.

- (1) Remove hardware connecting ground cable terminal lug to ground point.

1-17. ELECTRICAL GROUND POINTS (Con't).

WARNING

Cleaning compound, trichlorotrifluoroethane, for electrical parts is toxic and flammable, and reacts violently with aluminum, titanium, barium, lithium, samarium, sodium, and potassium. Always wear protective goggles and rubber gloves, and use only in a well-ventilated area. DO NOT wear jewelry while using cleaning compound. Avoid contact with skin, eyes, and clothes, and DO NOT breathe vapors. Cleaning compound fumes or vapors can take the place of air and may become a cancer producing agent. DO NOT use near open flame or excessive heat. The compound's boiling point is 114°F (46°C). If you become dizzy while using cleaning compound, immediately get fresh air and medical help. If compound contacts eyes, immediately wash your eyes with water and get medical aid,

- (2) Clean mounting hardware, ground cable terminal lugs, and ground point with trichlorotrifluoroethane (Item 31, Appendix B) and scrub brush (Item 3, Appendix B).
- (3) Remove any rust with wire brush and crocus cloth (Item 5, Appendix B).
- (4) Look for cracks, loose terminal lugs, and stripped threads. Replace any defective parts.
- (5) Install hardware connecting ground cable terminal lug to ground point. Ensure that all hardware is tight.

1-18. LINES AND PORTS.

To keep dirt from contaminating fluid systems when removing and installing hydraulic, fuel, oil, and coolant lines, perform the following steps:

- (1) Clean fittings and surrounding area before disconnecting lines.
- (2) Cover, cap, plug, or tape lines and ports after disconnecting lines. When these are not available, use hand-carved wooden plugs, clean rags (Item 17, Appendix B), duct tape (Item 27, Appendix B), or other similar materials to prevent dirt from entering system.
- (3) Ensure that new and used parts are clean before installing.
- (4) Wait to uncover, uncap, unplug, or remove tape from lines and ports until just before installing lines.

1-19. ANTISEIZING TAPE.

New antiseizing tape (Item 26, Appendix B) may be used to keep connections from leaking whenever you are connecting fuel, oil, and hydraulic system lines and fittings without compression sleeves or packings as follows:

- (1) Ensure that threads are clean and dry.
- (2) Start tape one or two threads from small or leading edge of fitting, joining tape together with an overlap of about X in. (3.18 mm) for fittings with fine threads. For fittings with coarse threads, tape should be wrapped around threads two or three times.
- (3) Wrap tape tightly in same direction as you tighten a nut. Tape must be pressed into threads without cutting or ripping.

1-19. ANTISEIZING TAPE (Con't).

CAUTION

Do not exceed specified torque or use power tools to tighten fittings taped with antiseizing tape. Overtightening could damage fitting threads and cause connection to leak.

- (4) Using hand tools, tighten fittings to specified torque.

1-20. TUBES AND COMPRESSION FITTINGS.

- a. Tubes with inverted nuts and compression fittings are designed for one-time assembly. Once assembled, they must be replaced as a unit if any parts are found defective. Used parts may not seal properly when used with new ones.
- b. Used tube assemblies in good condition can be installed to their original location without leaking.
- c. Assemble new tubes, compression sleeves, and inverted nuts as follows:
 - (1) Slide inverted nut onto end of tube.
 - (2) Slide compression sleeve onto end of tube.
 - (3) Repeat steps (1) and (2) for other end of tube as required.
- d. Install new tube assemblies as follows:
 - (1) Insert end of tube as far as it will go into fitting to which tube is being installed.
 - (2) Screw Inverted nut into fitting and tighten it against compression sleeve with open end wrench. Compression sleeve will clamp down around tube and conform to internal surface of fitting and inverted nut.
 - (3) Repeat steps (1) and (2) for other end of tube as required.

1-21. LOCKWIRE.

- a. Always use nonelectrical wire (Item 34, Appendix B).
- b. Drilled head screws and bolts usually do not require lockwiring if they are installed with self-locking nuts or lockwashers.
- c. Three screws or bolts are the maximum number that may be lockwired in a series when they are spaced 4-6 in. (10.16-15.24 cm) apart. The maximum number of closely-spaced multiple groups of screws or bolts to be lockwired, is limited to the number of units that can be lockwired with a 24 in. (60.96 cm) length of wire.
- d. Do not secure screws, bolts, or fittings which are spaced more than 6 in. (15.24 cm) apart. Lockwire these fasteners to tiepoints 6 in. (15.24 cm) or less away.
- e. Lockwire parts so that tension will be on lockwire when parts tend to loosen. Lockwire should be installed and twisted tightly so that loop around head stays down and does not come up over head of screw or bolt. This does not apply to castellated nuts when slot is close to top of nuts; wire is more secure when made to pass along the side of stud. Ensure that lockwire is tight but not overstressed.
- f. Make pigtail of Y-X in. (6.35-12.70 mm) at end of lockwire. Bend pigtail down so it will not become a snag.
- g. When lockwiring castellated nuts, tighten nut to low side of torque range, then continue tightening until slot lines up with hole.

1-22. FLUID DISPOSAL.

Dispose of contaminated drained fluids in accordance with the Standard Operating Procedures (SOP) of your unit.

1-23. TRANSMISSION.

a. Follow these MAINTENANCE instructions when repairing transmission:

(1) Handle transmission parts and subassemblies carefully to prevent nicking and scratching parts. Parts that fit together closely can bind if damaged. Use extreme care to avoid damaging internal parts of control valve. Parts that depend on smooth surfaces for sealing may leak oil if nicked or scratched.

(2) Do not use metal tools when removing gaskets and seals to avoid scratching metal sealing surfaces. Use pointed wood dowel to remove seals from grooves. Use wood or plastic scrapers to remove gasket material from sealing surfaces.

b. Follow these CLEANING Instructions when repairing transmission:

(1) All parts must be clean to permit effective inspection. At assembly, no dirt or foreign material can be allowed to enter transmission. Even small particles can cause malfunction of close-fitting parts, such as valves.

WARNING

- **Dry cleaning solvent, P-D-680, is toxic and flammable. Always wear protective goggles and gloves, and use only in a well-ventilated area. Avoid contact with skin, eyes, and clothes, and DO NOT breathe vapors. DO NOT use near open flame or excessive heat. The solvent's flash point is 100°F-138°F (38°C-59°C). If you become dizzy while using cleaning solvent, immediately get fresh air and medical help. If solvent contacts eyes, immediately wash your eyes and get medical aid.**

- **Avoid contact with live steam. Live steam can burn skin, cause blindness, and cause other serious injury. Be sure to wear protective apron, gloves, and safety goggles when using live steam.**

(2) All metal transmission parts, except bearings and clutch disks, should be cleaned thoroughly with dry cleaning solvent (Item 23, Appendix B). Large parts may be steam cleaned. Do not use caustic soda solution when steam cleaning.

WARNING

Compressed air used for cleaning or drying purposes, or for clearing restrictions should never exceed 30 psi (207 kPa). Wear protective clothing (goggles/shield, gloves, etc.) and use caution to avoid injury to personnel.

(3) Bearings should drip and air dry, then a thin coat of hydraulic fluid (Item 7, Appendix B) should be applied. Parts may be wiped dry with clean lint-free wipes (Item 33, Appendix B) or allowed to air dry. Parts with oil passages should be dried with compressed air.

1-23. TRANSMISSION (Con't).

WARNING

- Dry cleaning solvent, P-D-680, is toxic and flammable. Always wear protective goggles and gloves, and use only in a well-ventilated area. Avoid contact with skin, eyes, and clothes, and DO NOT breathe vapors. DO NOT use near open flame or excessive heat. The solvent's flash point is 1000F-138°F (380C-59°C). If you become dizzy while using cleaning solvent, immediately get fresh air and medical help. If solvent contacts eyes, immediately wash your eyes and get medical aid.
- Compressed air used for cleaning or drying purposes, or for clearing restrictions, should never exceed 30 psi (207 kPa). Wear protective clothing (goggles/shield, gloves, etc.) and use caution to avoid injury to personnel.

(4) Clean oil passages by working a piece of soft wire through the passages and flushing with dry cleaning solvent (Item 23, Appendix B). Dry passages with compressed air.

(5) Inspect parts, especially oil passages, after cleaning to ensure they are clean. Clean again if necessary.

c. Follow these INSPECTION instructions when repairing transmission: (1) Inspect surfaces in contact with gaskets or seals for nicks, burrs, or scratches. Remove any defects before assembly.

(2) After cleaning, oil bearings with thin coat of hydraulic fluid (Item 7, Appendix B) to prevent corrosion.

(3) Inspect bores for wear, scratches, grooves, burrs, and dirt. Remove scratches and burrs with crocus cloth, then clean thoroughly. Clean dirt and foreign matter from parts. Replace parts that are deeply scratched or grooved.

(4) Inspect housings and other cast parts for cracks. Replace parts that are cracked.

(5) Inspect machined surfaces for damage that may cause malfunction or oil leakage. Replace damaged parts.

(6) Inspect gears for worn or broken teeth. Replace damaged gears.

(7) Inspect face of gears for scoring or burrs. Remove defects with soft stone, then clean thoroughly. If scoring or burrs cannot be removed with soft stone, replace gear.

(8) Inspect splined parts for chipped or burred splines. Remove burrs with soft stone, then clean thoroughly. Spline wear is not considered cause for part replacement.

(9) Inspect retaining rings for distortion and looseness. Retaining ring must snap tightly into groove. Replace retaining ring if damaged.

(10) Inspect for broken, deformed, or worn springs. Replace spring if damaged.

(11) Inspect clutch disks (internal splined) for burrs, embedded metal particles, loose or missing facings, excessive wear, cracks, distortion, and damaged spline teeth. Replace clutch disks if damaged.

(12) Inspect clutch plates (external splined) for burrs, scoring, excessive wear, distortion, cracks, and damaged spline teeth. Replace clutch plates if damaged.

(13) Inspect surface of parts contacted by hook-type and step-joint seal rings for wear, scratches, and scoring. Remove only raised metal portion of defect with soft stone or crocus cloth (item 5, Appendix B), then clean thoroughly. Polishing to remove defect is not necessary or desirable. If defect permits oil leakage, replace defective part.

(14) Inspect surface of parts contacted by spring-loaded, lip-type oil seals for scratches, roughness, embedded dirt, and wear. Remove defects and restore finish with crocus cloth, then clean thoroughly. If defect permits oil leakage, replace defective part.

CHAPTER 2
TROUBLESHOOTING INSTRUCTIONS

Paragraph Number	Paragraph Title	Page Number
2-1	General.....	2-1
2-2	Explanation of Columns	2-2
2-3	Troubleshooting Symptom Index	2-2
Table 2-1	Troubleshooting.....	2-3

2-1. GENERAL.

a. This section provides information for identifying and correcting malfunctions which may develop while operating your dump truck.

b. The Troubleshooting Symptom Index in paragraph 2-3 lists common malfunctions which may occur and refers you to the proper page in Table 2-1 for a troubleshooting procedure.

c. If you are unsure of the location of an item mentioned in troubleshooting, refer to TM 5-3805-254-10 or to the maintenance task where the item is replaced.

d. Before performing troubleshooting, read and follow all safety instructions found in the Warning Summary at the front of this manual.

e. This section cannot list all malfunctions that may occur, nor all tests or inspections and corrective actions. If a malfunction is not listed, or is not corrected by the listed corrective actions, notify your supervisor.

f. When troubleshooting a malfunction:

(1) Locate the symptom or symptoms in paragraph 2-3 that best describe the malfunction.

(2) Turn to the page in Table 2-1 where the troubleshooting procedures for the malfunction in question are described. Headings at top of each page show how each troubleshooting procedure is organized: MALFUNCTION, TEST OR INSPECTION (in step number order), and CORRECTIVE ACTION.

(3) Perform each step in the order listed until the malfunction is corrected. DO NOT perform any maintenance task unless the troubleshooting procedure tells you to do so.

2-2. EXPLANATION OF COLUMNS.

The columns in Table 2-1 are defined as follows:

- (1) **MALFUNCTION.** A visual or operational indication that something is wrong with the dump truck.
- (2) **TEST OR INSPECTION.** A procedure to isolate the problem in a component or system.
- (3) **CORRECTIVE ACTION.** A procedure to correct the problem.

2-3. TROUBLESHOOTING SYMPTOM INDEX.

	Troubleshooting Procedure Page
 COOLING SYSTEM	
Coolant Temperature:	
Above Normal	2-6
Below Normal.....	2-6
 ENGINE ASSEMBLY	
Engine Oil in Coolant or Coolant in Engine Oil.....	2-4
Excessive:	
Noise.....	2-5
Vibration.....	2-5
Fails to Crank	2-3
Hard to Start or Fails to Start.....	2-3
Low Power.....	24
Stops and Will Not Start	2-4
 ENGINE COMPRESSION BRAKE	
Engaged With Switch in OFF Position	2-5
Weak or Slow to Activate	2-5
 TRANSMISSION	
Creeps:	
Excessively When in:	
First Gear	2-8
Reverse	2-8
Fails to Respond to Shift Control	2-8
When in Neutral	2-7
Oil:	
Dirty.....	2-10
Leaking:	
At Output Shaft.....	2-10
Into Torque Converter	2-10

2-3. TROUBLESHOOTING SYMPTOM INDEX (Con't).

	Troubleshooting Procedure Page
TRANSMISSION (Con't)	
Oil (Con't):	
Pressure Low	2-9
Pressure Low in One Gear, Normal in Other Gears	2-9
Thrown from Filler Tube.....	2-10
Overheats	2-8
Shifts:	
Roughly	2-8
When Speed of Vehicle is:	
Too Low	2-9
Too High	2-9
Slips in:	
All Forward Gears	2-6
Fifth Gear and Reverse.....	2-7
First Gear and Reverse.....	2-7
Fourth Gear Only	2-7
Second Gear Only	2-7
Third Gear Only	2-7

Table 2-1. Troubleshooting.

MALFUNCTION
TEST OR INSPECTION
CORRECTIVE ACTION

ENGINE ASSEMBLY

1. ENGINE FAILS TO CRANK.

- Step 1. Inspect flywheel ring gear for broken teeth (see paragraph 6-10).
 Replace damaged flywheel (see paragraph 6-10).
- Step 2. Check for seized engine.
 Replace engine (see paragraph 3-1).

2. ENGINE HARD TO START OR FAILS TO START.

- Step 1. Inspect for plugged fuel injectors (see TM 5-2815-241-34&P).
 Clean or replace plugged or damaged fuel injectors (see TM 5-2815-241-34&P).
- Step 2. Inspect for broken fuel pump shaft (see TM 5-2815-241-34&P).
 Repair fuel pump (see TM 5-2815-241-34&P).

Table 2-1. Troubleshooting (Con't).

MALFUNCTION	TEST OR INSPECTION	CORRECTIVE ACTION
Step 3.	Inspect fuel pump for scored or worn gears (see TM 5-2815-241-34&P).	Repair fuel pump (see TM 5-2815-241-34&P).
Step 4.	Check fuel pump injector timing (see TM 5-2815-241-34&P).	Adjust fuel pump injector timing (see TM 5-2815-241-34&P).
Step 5.	Inspect for broken piston rings and damaged pistons (see TM 5-2815-241-34&P).	Replace engine (see paragraph 3-1).
Step 6.	Inspect for out-of-round, scored, and damaged cylinder liners (see TM 5-2815-241-34&P).	Replace engine (see paragraph 3-1).
3. ENGINE OIL IN COOLANT OR COOLANT IN ENGINE OIL.		
Step 1.	Inspect for leaking cylinder head gasket (see TM 52815-241-34&P).	Replace cylinder head gasket (see TM 5-2815-241-34&P).
Step 2.	Inspect for cracked cylinder block.	Replace engine (see paragraph 3-1).
4. LOW ENGINE POWER.		
Step 1.	Inspect for leaking cylinder head gasket (see TM 5-2815-241-34&P).	Replace cylinder head gasket (see TM 5-2815-241-34&P).
Step 2.	Inspect valves for wear and damage (see TM 5-2815-241-34&P).	Repair or replace valves (see TM 5-2815-241-34&P).
Step 3.	Check fuel pump injector timing (see TM 5-2815-241-34&P).	Adjust fuel pump injector timing (see TM 5-2815-241-34&P).
Step 4.	Inspect for broken and worn piston rings (see TM 5-2815-241-34&P).	Replace engine (see paragraph 3-1).
5. ENGINE STOPS AND WILL NOT START.		
Step 1.	Inspect for broken fuel pump shaft (see TM 5-2815-241-34&P).	Repair fuel pump (see TM 5-2815-241-34&P).
Step 2.	Inspect fuel pump for scored or worn gears (see TM 5-2815-241-34&P).	Repair fuel pump (see TM 5-2815-241-34&P).

Table 2-1. Troubleshooting (Con't).

MALFUNCTION	TEST OR INSPECTION	CORRECTIVE ACTION
6. EXCESSIVE ENGINE NOISE.		
	Inspect for internal engine wear and damage to main bearings, connecting rods, camshafts, and journals (see TM 5-2815-241-34&P).	Replace engine (see paragraph 3-1).
7. EXCESSIVE ENGINE VIBRATION.		
Step 1.	Inspect for faulty vibration damper (see TM 5-2815-241-34&P).	Replace vibration damper (see TM 5-2815-241-34&P).
Step 2.	Inspect for loose and damaged engine mounts (see paragraph 3-3).	Tighten or replace engine mounts (see paragraph 3-3).
Step 3.	Inspect for loose flywheel (see paragraph 6-10).	Tighten flywheel (see paragraph 6-10).

ENGINE COMPRESSION BRAKE

8. ENGINE COMPRESSION BRAKE ENGAGED WITH SWITCH IN "OFF" POSITION.

- | | | |
|---------|---|---|
| Step 1. | Inspect for solenoid valve plunger stuck in ON position (see TM 5-2815-241-34&P). | Replace solenoid valve (see TM 5-2815-241-34&P). |
| Step 2. | Inspect for faulty solenoid valve seals (see TM 5-2815-241-34&P). | Replace solenoid valve seals (see TM 5-2815-241-34&P). |
| Step 3. | Inspect for broken control valve spring (see TM 5-2815-241-34&P). | Replace control valve spring (see TM 5-2815-241-34&P). |
| Step 4. | Inspect for control valve stuck in ON position (see TM 5-2815-241-34&P). | Free or replace control valve (see TM 5-2815-241-34&P). |

9. ENGINE COMPRESSION BRAKE WEAK OR SLOW TO ACTIVATE.

- | | | |
|---------|---|--|
| Step 1. | Inspect for sticking slave piston (see TM 5-2815-241-34&P). | Free or replace slave piston (see TM 5-2815-241-34&P). |
| Step 2. | Inspect for broken control valve spring (see TM 5-2815-241-34&P). | Replace control valve spring (see TM 5-2815-241-34&P). |

Table 2-1. Troubleshooting (Con't).

MALFUNCTION	TEST OR INSPECTION	CORRECTIVE ACTION
Step 3.	Inspect for sticking control valve (see TM 5-2815-241-34&P).	Free or replace control valve (see TM 5-2815-241-34&P).
Step 4.	Inspect for sticking master piston (see TM 5-2815-241-34&P).	Free or replace master piston (see TM 5-2815-241-34&P).

COOLING SYSTEM

10. COOLANT TEMPERATURE ABOVE NORMAL.

- Step 1. Inspect for damage to radiator cooling fins (see paragraph 4-4).
 Repair or replace radiator (see paragraph 4-4).
- Step 2. Inspect for obstructed radiator core (see paragraph 4-4).
 Repair or replace radiator (see paragraph 4-4).
- Step 3. Inspect for damaged radiator shroud (see paragraph 4-5).
 Replace radiator shroud (see paragraph 4-5).
- Step 4. Check for missing water pump belts.
 Replace water pump belts (see TM 5-2815-241-34&P).
- Step 5. Check for leaking water manifold or water pump.
 Replace water manifold or water pump (see TM 5-2815-241-34&P).

11. COOLANT TEMPERATURE BELOW NORMAL.

- Check for radiator shutter stuck open.

 Replace radiator shutter (see paragraph 4-1).

TRANSMISSION

12. TRANSMISSION SLIPS IN ALL FORWARD GEARS.

- Step 1. Check level of transmission oil (see TM 5-3805-254-10).
 Add transmission oil if low (see TM 5-3805-254-20).

Table 2-1. Troubleshooting (Con't).

MALFUNCTION	TEST OR INSPECTION	CORRECTIVE ACTION
Step 2.	Inspect for clogged transmission internal oil filter element (see TM 5-3805-254-20).	Replace oil filter element (see TM 5-3805-254-20).
Step 3.	Inspect front support seal rings for wear or damage (see paragraph 6-29).	Repair front support (see paragraph 6-29).
Step 4.	Inspect forward clutch seal rings for wear or damage (see paragraph 6-30).	Repair forward clutch (see paragraph 6-30).
13. TRANSMISSION SLIPS IN FIRST GEAR AND REVERSE.		
	Inspect low clutch seal rings for wear or damage (see paragraph 6-21).	Replace low clutch (see paragraph 6-21).
14. TRANSMISSION SLIPS IN FIFTH GEAR AND REVERSE.		
	Inspect fourth clutch seal rings for wear or damage (see paragraph 6-31).	Repair fourth clutch (see paragraph 6-31).
15. TRANSMISSION SLIPS IN SECOND GEAR ONLY.		
	Inspect first clutch seal rings for wear or damage (see paragraph 6-23).	Replace first clutch (see paragraph 6-23).
16. TRANSMISSION SLIPS IN THIRD GEAR ONLY.		
	Inspect second clutch seal rings for wear or damage (see paragraph 6-26).	Replace second clutch (see paragraph 6-26).
17. TRANSMISSION SLIPS IN FOURTH GEAR ONLY.		
	Inspect third clutch seal rings for wear or damage (see paragraph 6-18).	Replace third clutch (see paragraph 6-18).
18. VEHICLE CREEPS WITH TRANSMISSION IN NEUTRAL.		
Step 1.	Inspect transmission shift cable for damage (see TM 5-3805-254-20).	Replace transmission shift cable (see TM 5-3805-254-20).
Step 2.	Inspect transmission shift cable for out of adjustment (see TM 5-3805-254-20).	Adjust transmission shift cable (see TM 5-3805-254-20).

Table 2-1. Troubleshooting (Con't).

MALFUNCTION	TEST OR INSPECTION	CORRECTIVE ACTION
Step 3.	Inspect forward clutch for damage (see paragraph 6-16).	Repair forward clutch (see paragraph 6-30).
Step 4.	Inspect fourth clutch for damage (see paragraph 6-17).	Repair fourth clutch (see paragraph 6-31).
19. VEHICLE CREEPS EXCESSIVELY WITH TRANSMISSION IN FIRST GEAR AND REVERSE.		
Check engine idle speed (see TM 5-3805-254-34&P). Adjust engine Idle speed (see TM 5-3805-254-34&P).		
20. TRANSMISSION SHIFTS ROUGHLY.		
Step 1.	Inspect transmission shift cable for damage (see TM 5-3805-254-20).	Replace transmission shift cable (see TM 5-3805-254-20).
Step 2.	Inspect transmission shift cable for out of adjustment (see TM 5-3805-254-20).	Adjust transmission shift cable (see TM 5-3805-254-20).
Step 3.	Inspect for defective transmission control valve (see paragraph 6-34).	Repair transmission control valve (see paragraph 6-34).
Step 4.	Inspect for defective transmission modulator valve (see paragraph 6-7).	Repair transmission modulator valve (see paragraph 6-7).
21. TRANSMISSION OVERHEATS.		
Step 1.	Check level of transmission oil (see TM 5-3805-254-10).	Add transmission oil if low (see TM 5-3805-254-20). Drain transmission oil if high (see TM 5-3805-254-20).
Step 2.	Inspect for clogged torque converter cooler (see paragraph 6-6).	Perform maintenance on transmission torque converter cooler (see paragraph 6-6).
22. TRANSMISSION FAILS TO RESPOND TO SHIFT CONTROL.		
Step 1.	Inspect transmission shift cable for damage (see TM 5-3805-254-20).	Replace transmission shift cable (see TM 5-3805-254-20).
Step 2.	Check gage for low transmission oil pressure (see TM 5-3805-254-20).	Replace transmission oil filter element (see TM 5-3805-254-20). Replace seal ring of transmission oil filter element (see TM 5-3805-254-20). Repair transmission oil pump (see paragraph 6-28). Repair transmission control valve (see paragraph 6-34).

Table 2-1. Troubleshooting (Con't).

MALFUNCTION	TEST OR INSPECTION	CORRECTIVE ACTION
23.	TRANSMISSION SHIFTS WHEN SPEED OF VEHICLE IS TOO LOW.	
Step 1.	Inspect for defective transmission modulator valve in transmission control valve (see paragraph 6-14).	Repair transmission modulator valve in transmission control valve (see paragraph 6-34).
Step 2.	Inspect for defective shift signal valve in transmission control valve (see paragraph 6-14).	Repair transmission shift signal valve in transmission control valve (see paragraph 6-34).
Step 3.	Inspect for defective transmission governor assembly (see paragraph 6-35).	Replace transmission governor assembly (see paragraph 6-35).
24.	TRANSMISSION SHIFTS WHEN SPEED OF VEHICLE IS TOO HIGH.	
Step 1.	Inspect for defective transmission governor assembly (see paragraph 6-35).	Replace transmission governor assembly (see paragraph 6-35).
Step 2.	Inspect for defective shift signal valve in transmission control valve (see paragraph 6-14).	Repair transmission shift signal valve in transmission control valve (see paragraph 6-34).
25.	TRANSMISSION OIL PRESSURE LOW.	
Step 1.	Check level of transmission oil (see TM 5-3805-254-10).	Add transmission oil if low (see TM 5-3805-254-20).
Step 2.	Inspect for clogged transmission internal oil filter element (see TM 5-3805-254-20).	Replace oil filter element (see TM 5-3805-254-20).
Step 3.	Inspect seal ring of transmission oil filter element (see TM 5-3805-254-20).	Replace seal ring of transmission oil filter element (see TM 5-3805-254-20).
Step 4.	Inspect for defective transmission oil pump (see paragraph 6-28).	Repair transmission oil pump (see paragraph 6-28).
Step 5.	Inspect for defective transmission control valve (see paragraph 6-14).	Repair transmission control valve (see paragraph 6-34).
26.	TRANSMISSION OIL PRESSURE LOW IN ONE GEAR, NORMAL IN OTHER GEARS.	
Step 1.	Inspect for defective transmission control valve (see paragraph 6-14).	Repair transmission control valve (see paragraph 6-34).
Step 2.	Inspect for defective seal rings in piston of gear with low pressure.	Repair transmission.

Table 2-1. Troubleshooting (Con't).

MALFUNCTION	TEST OR INSPECTION	CORRECTIVE ACTION
27. TRANSMISSION OIL DIRTY.		
Step 1.	Inspect for damaged transmission internal oil filter element (see TM 5-3805-254-20). Replace oil filter element (see TM 5-3805-254-20).	
Step 2.	Inspect for transmission clutch failure. Repair transmission.	
28. TRANSMISSION OIL THROWN FROM FILLER TUBE.		
Step 1.	Check level of transmission oil (see TM 5-3805-254-10). Drain transmission oil if too high (see TM 5-3805-254-20).	
Step 2.	Check for clogged transmission breather (see paragraph 6-27). Replace transmission breather (see paragraph 6-27).	
Step 3.	Inspect for defective torque converter cooler (see paragraph 6-6). Repair torque converter cooler (see paragraph 6-6).	
29. TRANSMISSION OIL LEAKING AT OUTPUT SHAFT.		
	Inspect for defective packing retainer and oil seal (see paragraph 6-36).	Replace packing retainer and oil seal (see paragraph 6-36).
30. TRANSMISSION OIL LEAKING INTO TORQUE CONVERTER.		
	Inspect for defective hub seal of torque converter (see paragraph 6-11).	Replace hub seal (see paragraph 6-11).

**CHAPTER 3
ENGINE MAINTENANCE**

Paragraph Number	Paragraph Title	Page Number
3-1	Engine Replacement	3-2
3-2	Fuel Lines Replacement	3-8
3-3	Engine Mounts Replacement.....	3-12

3-1. ENGINE REPLACEMENT.

This Task Covers:

a. Removal

*Initial Setup:***Equipment Conditions:**

- Batteries disconnected. (see TM 5-3805-254-20).
- Front fenders removed (see paragraph 15-24).
- Grille guard removed (See TM 5-3805-254-20).
- Front bumper removed (see TM 5-3805-254-20).
- Turbocharger piping removed (see TM 5-3805-254-20).
- 6 Ail cleaner housing removed (see TM 5-3805-254-20).
- Turbocharger crossover tube removed (see TM 5-2815-241-34&P).
- Alcohol evaporator removed (see TM 5-3805-254-20).
- Primary fuel filter housing removed (see TM 5-3805-254-20).
- Primer pump fuel hose disconnected from fuel pump (see TM 5-3805-254-20).
- Preheater fuel hose disconnected from preheated nozzle (see TM 5-3805-254-20).
- Glow plug wire disconnected from glow plug (see TM 5-3805-254-20).
- Accelerator control disconnected from fuel pump (see TM 5-3805-254-20).
- Auxiliary oil filter hoses disconnected from left side of engine (see TM 5-3805-254-20).
- Tachometer drive cable disconnected from fuel pump (see TM 5-3805-254-20).
- Ground strap removed from left side of engine crankcase (see TM 5-3805-254-20).
- Oil pressure switch wire disconnected from fuel solenoid of fuel pump (see TM 5-3805-254-20).
- Engine compression brake throttle switch removed from fuel pump (see TM 5-3805-254-20).
- Steering pump bypass hose and fittings removed (see TM 5-3805-254-20).
- Torque converter cooler removed (see paragraph 6-6).
- Radiator bypass coolant line removed (see TM 5-3805-254-20).

b. Installation

Equipment Conditions (Con't):

- Heater core hoses disconnected from water pump and water manifold (see TM 5-3805-254-20).
- Engine water temperature switch wires disconnected (see TM 5-3805-254-20).
- Radiator removed (see paragraph 4-4).
- Exhaust pipe elbow disconnected from turbocharger (see TM 5-3805-254-20).
- Water temperature gage line removed (see TM 5-3805-254-20).
- Air compressor to air dryer hose disconnected from air compressor (see TM 5-3805-254-20).
- Air compressor governor to air dryer air line disconnected from air compressor (see TM 5-3805-254-20).
- Air compressor governor to wet air reservoir line disconnected from air compressor governor (see TM 5-3805-254-20).
- Power steering oil reservoir removed (see TM 5-3805-254-20).
- Engine cover removed (see paragraph 15-1).
- Floorboards and inserts removed (see paragraph 15-3).

Materials/Parts:

- Two cotter pins
- Two locknuts
- Sixteen lockwashers

Tools/Test Equipment:

- General mechanic's tool kit
- Field automotive shop set
- Lifting eye

Personnel Required: Two

References:

- TM 5-3805-254-20

3-1. ENGINE REPLACEMENT (Con't).

a. REMOVAL

- 1. Remove four nuts (3) and lockwashers (4) from four studs (1) at top of engine (5). Discard lockwashers.
- 2. Install lifting eye (2) to four studs (1) and install four new lockwashers (4) and nuts (3).

WARNING

Use extreme caution when handling engine. Lifting device is required when parts weigh over 50 lb (23 kg) for a single person lift, over 100 lb (45 kg) for a two person lift, and over 150 lb (68 kg) for a three or more person lift. Keep clear of heavy parts supported only by lifting device. Failure to follow this warning may result in serious injury or death to personnel.

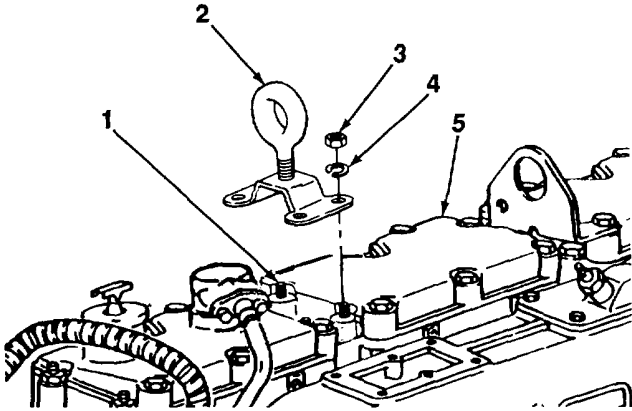

- 3. Attach overhead lifting device to lifting eye (2) and raise overhead lifting device just enough to take weight of engine (5) off engine mounts (14).
- 4. Using floor jack or wood cribbing, support front of transmission (15).
- 5. Remove two screws (10), lockwashers (9), and housing cover (8) from right side of engine flywheel housing (7). Discard lockwashers.

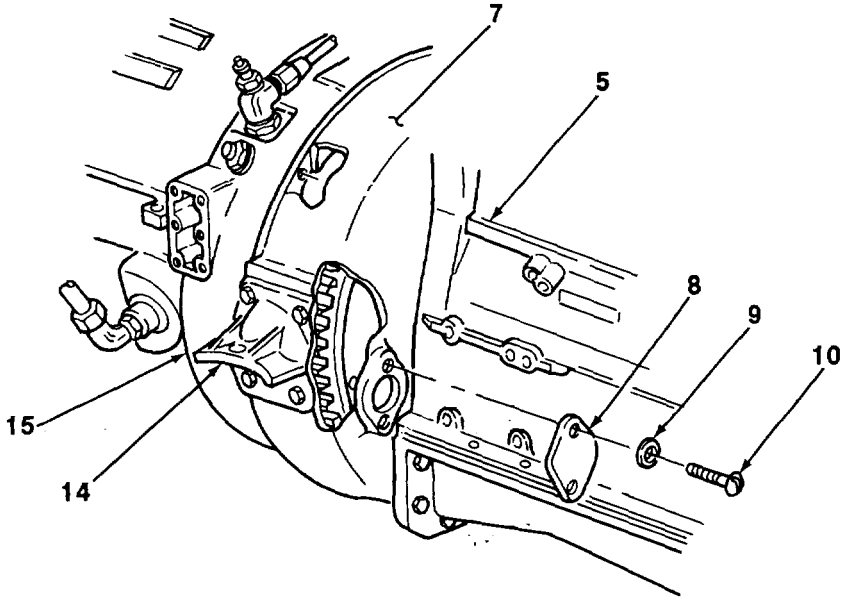

3-1. ENGINE REPLACEMENT (Con't).**CAUTION**

Rotate engine only in normal operating direction to prevent damage to engine.

NOTE

Normal rotation of engine is clockwise when facing front of engine.

6. While rotating engine (5) to each of 12 screw (11) positions, remove screws to disconnect flywheel (13) from engine flexplate (12).

WARNING

Use extreme caution when handling transmission. Lifting device is required when parts weigh over 50 lb (23 kg) for a single person lift, over 100 lb (45 kg) for a two person lift, and over 150 lb (68 kg) for a three or more person lift. Keep clear of heavy parts supported only by lifting device. **DO NOT** remove bolts unless transmission is supported. Failure to follow this warning may result in serious injury or death to personnel.

7. Remove 12 bolts (6) to separate engine (5) from transmission (15).

NOTE

Perform step 8 at left and right rear engine mounts.

8. Remove cotter pin, nut, two washers, and bolt from rear engine mount (see paragraph 3-3).

NOTE

Perform step 9 at left and right front engine mount bracket.

9. Remove locknut, two washers, and bolt from front engine mount bracket (see paragraph 3-3).

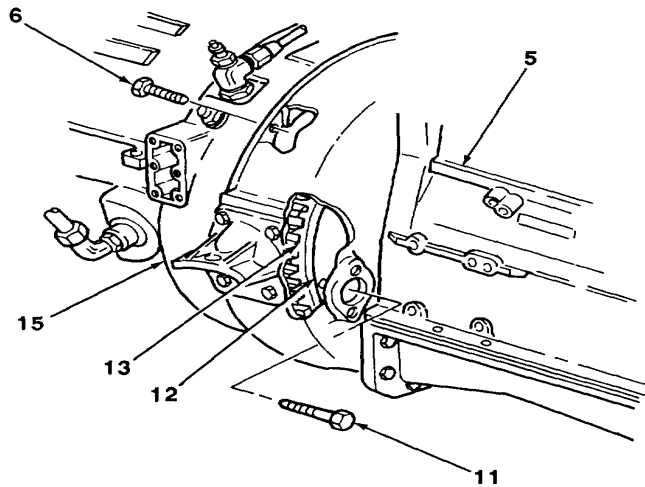

TA703647

3-1. ENGINE REPLACEMENT (Con't).**WARNING**

Use extreme caution when handling engine. Lifting device is required when parts weigh over 50 lb (23 kg) for a single person lift, over 100 lb (45 kg) for a two person lift, and over 150 lb (68 kg) for a three or more person lift. Keep clear of heavy parts supported only by lifting device. Failure to follow this warning may result in serious injury or death to personnel.

10. Remove engine (5) from vehicle.

NOTE

If engine is to be replaced with another, perform the following steps to remove items from the unserviceable engine and install on serviceable engine.

11. Remove and install starter motor (see TM 5-3805-254-20).
12. Remove and install generator (see TM 5-3805-254-20).
13. Remove and install steering pump (see paragraph 12-7).
14. Remove and install torque converter cooler (see paragraph 6-6).
15. Remove and install radiator fan (see paragraph 4-6).
16. Remove and install lifting eye.
17. Remove all other serviceable items from unserviceable engine and install on serviceable engine.

b. INSTALLATION

1. Attach overhead lifting device to lifting eye (2).

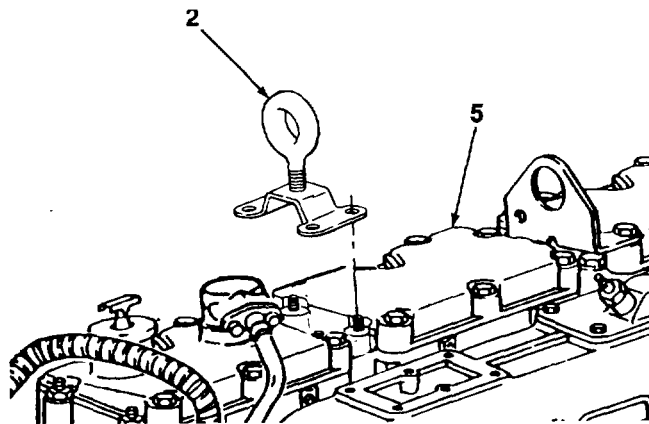
**WARNING**

Use extreme caution when handling engine. Lifting device is required when parts weigh over 50 lb (23 kg) for a single person lift, over 100 lb (45 kg) for a two person lift, and over 150 lb (68 kg) for a three or more person lift. Keep clear of heavy parts supported only by lifting device. Failure to follow this warning may result in serious injury or death to personnel.

2. Raise engine (5) and position engine to vehicle.

3-1. ENGINE REPLACEMENT (Con't).

3. Aline engine flywheel housing (7) to front of transmission (15) and install 12 bolts (6). Torque bolts to 150 lb.-ft, (203 N•m).
4. Remove floor jack or wood cribbing supporting front of transmission (15).
5. While rotating engine (5) to each of 12 screw (11) positions, connect flywheel (13) to engine flexplate (12) with 12 screws. Torque screws to 96-115 lb.-ft. (130-156 Nom).
6. Install housing cover (8) to engine flywheel housing (7) with two new lockwashers (9) and screws (10).

NOTE

Perform step 7 at left and right rear engine mounts.

7. Using overhead lifting device, position engine (5) and engine mounts (14) and install bolt, two washers, nut, and new cotter pin (see paragraph 3-3).

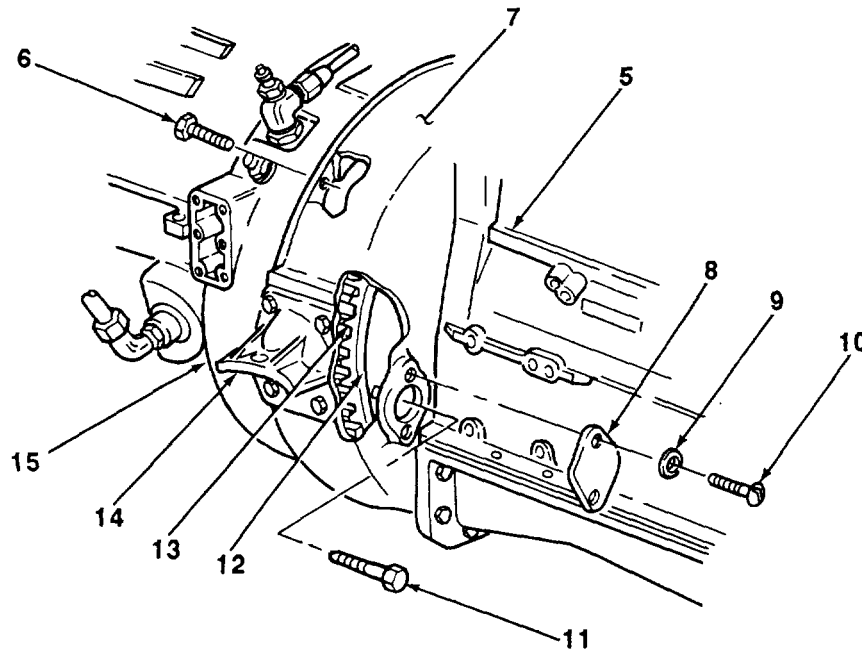
**NOTE**

Perform step 8 at left and right front engine mount bracket.

8. Using overhead lifting device, position front engine mount bracket to crossmember and install bolt, two washers, and new locknut (see paragraph 3-3).

TA703649

3-1. ENGINE REPLACEMENT (Con't).

9. Remove overhead lifting device from lifting eye (2).

NOTE

Perform steps 10 and 11 to remove lifting eye.

10. Remove four nuts (3) and lockwashers (4) from four studs (1) at top of engine (5). Discard lockwashers.
11. Remove lifting eye (2) and install four new lockwashers (4) and nuts (3). Torque nuts to 55-60 lb.-ft. (75-81 N•m).

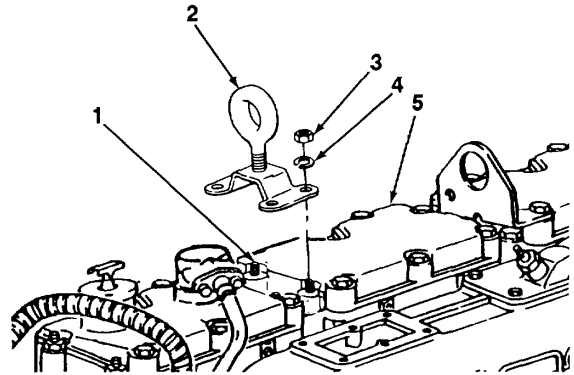
**FOLLOW-ON TASKS:**

- Install floorboards and inserts (see paragraph 15-3).
- Install engine cover (see paragraph 15-1).
- Install power steering oil reservoir (see TM 5-3805-254-20).
- Connect air compressor governor to wet air reservoir line to air compressor governor (see TM 5-3805-254-20).
- Connect air compressor governor to air dryer air line to air compressor (see TM 5-3805-254-20).
- Connect air compressor to air dryer hose to air compressor (see TM 5-3805-254-20).
- Install water temperature gage line (see TM 5-3805-254-20).
- Connect exhaust pipe elbow to turbocharger (see TM 5-3805-254-20).
- Install radiator (see paragraph 4-4).
- Connect engine water temperature switch wires (see TM 5-3805-254-20).
- Connect heater core hoses from water pump and water manifold (see TM 5-3805-254-20).
- Install radiator bypass coolant line (see TM 5-3805-254-20).
- Install torque converter cooler (see paragraph 6-6).
- Install steering pump bypass hose and fittings (see TM 5-3805-254-20).
- Install engine compression brake throttle switch to fuel pump (see TM 5-3805-254-20).
- Connect oil pressure switch wire to fuel solenoid of fuel pump (see TM 5-3805-254-20).
- Install ground strap to left side of engine crankcase (see TM 5-3805-254-20).
- Connect tachometer drive cable to fuel pump (see TM 5-3805-254-20).
- Connect auxiliary oil filter hoses to left side of engine (see TM 5-3805-254-20).
- Connect accelerator control to fuel pump (see TM 5-3805-254-20).
- Connect glow plug wire to glow plug (see TM 5-3805-254-20).
- Connect preheater fuel hose to preheater nozzle (see TM 5-3805-254-20).
- Connect primer pump fuel hose to fuel pump (see TM 5-3805-254-20).
- Install primary fuel filter housing (see TM 5-3805-254-20).
- Install alcohol evaporator (see TM 5-3805-254-20).
- Install turbocharger crossover tube (see TM 5-2815-241-34&P).
- Install air cleaner housing (see TM 5-3805-254-20).
- Install turbocharger piping (see TM 5-3805-254-20).
- Install front bumper (see TM 5-3805-254-20).
- Install grille guard (see TM 5-3805-254-20).
- Install front fenders (see paragraph 15-24).
- Connect batteries (see TM 5-3805-254-20).

TA703650

3-2. FUEL LINES REPLACEMENT (Con't).

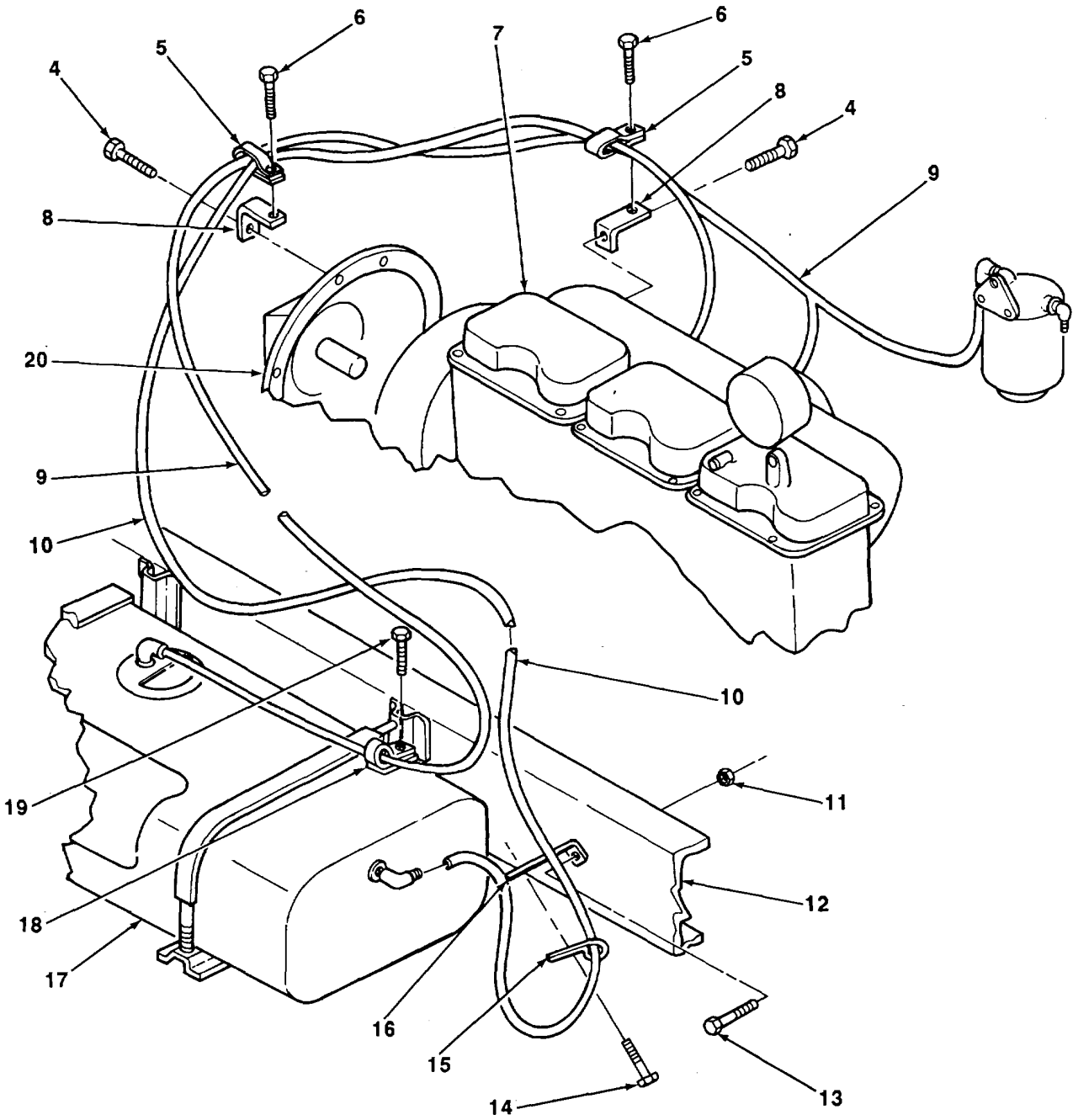

b. INSTALLATION

- 1. Install extension clip (8) on engine (7) with screw (4).
- 2. Install extension clip (8) on transmission housing (20) with screw (4).

3-2. FUEL LINES REPLACEMENT (Con't).

- 3. Install hose assemblies (9 and 10) on vehicle with two clamps (5) and screws (6).
- 4. Install hose assembly (9) on fuel tank (17) with clamp (18) and screw (19).
- 5. Install extension clip (16) on frame (12) with screw (13) and nut (11).
- 6. Install hose assembly (10) on extension clip (16) with clamp (15) and screw (14).

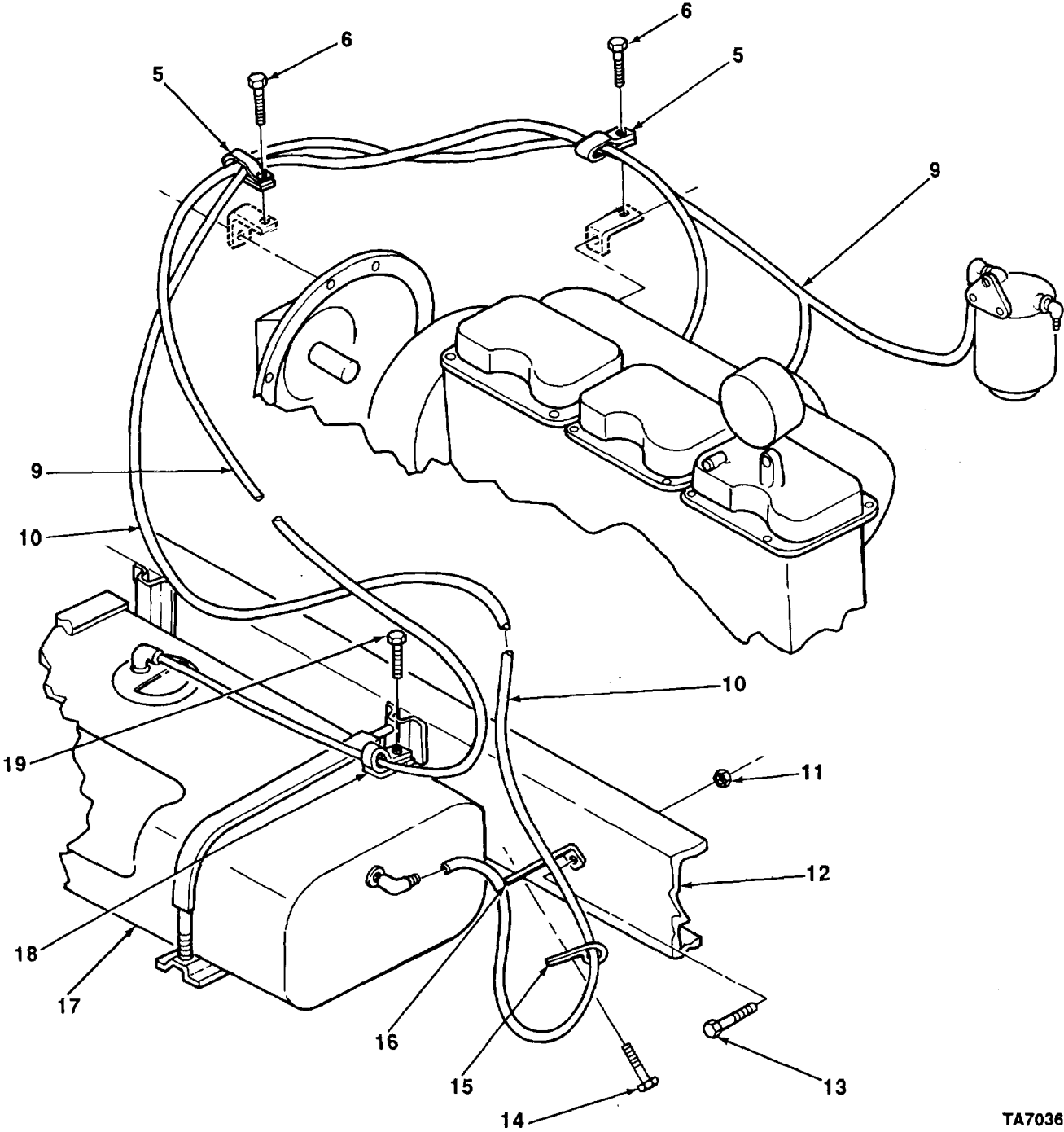

TA703653

TA703653

3-2. FUEL LINES REPLACEMENT (Con't).

7. Install elbow (3) and hose assembly (2) on fuel pump (1).

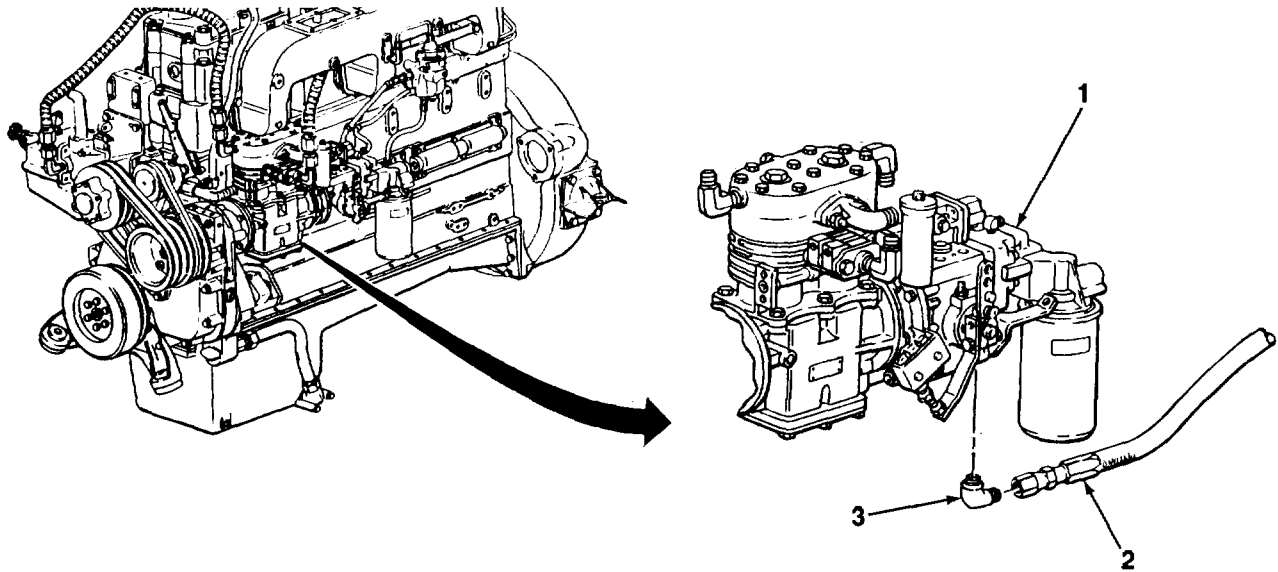
**FOLLOW-ON TASKS:**

- Connect hose assemblies to fuel filter housing (see TM 5-3805-254-20).
- Connect hose assemblies to fuel tank (see TM 5-3805-254-20).
- Close left and right hood (see TM 5-3805-254-10).

TA703654

3-3. ENGINE MOUNTS REPLACEMENT.

This Task Covers:

- a. Removal b. Installation
-

Initial Setup:

Equipment Conditions:

- Hood removed (see TM 5-3805-254-20).
- Radiator removed (see paragraph 4-4).

Materials/Parts:

- Two cotter pins
- Two locknuts
- Eight lockwashers

Tools/Test Equipment:

Personnel Required: Two

- General mechanic's tool kit
 - Field automotive shop set
-

a. REMOVAL**NOTE**

Perform steps 1 through 3 to remove front engine mounts.

1. Support engine (4) with suitable lifting device.
2. Raise engine (4) just enough to take weight of engine off front engine mount insulator washers (1 and 8).

NOTE

Perform step 3 at left and right side of engine mount bracket.

3. Remove locknut (3), flatwasher (2), insulator washers (1 and 8), bolt (7), and washer (6) from front engine mount bracket (9) and crossmember (5). Discard locknut.

3-3. ENGINE MOUNTS REPLACEMENT (Con't).

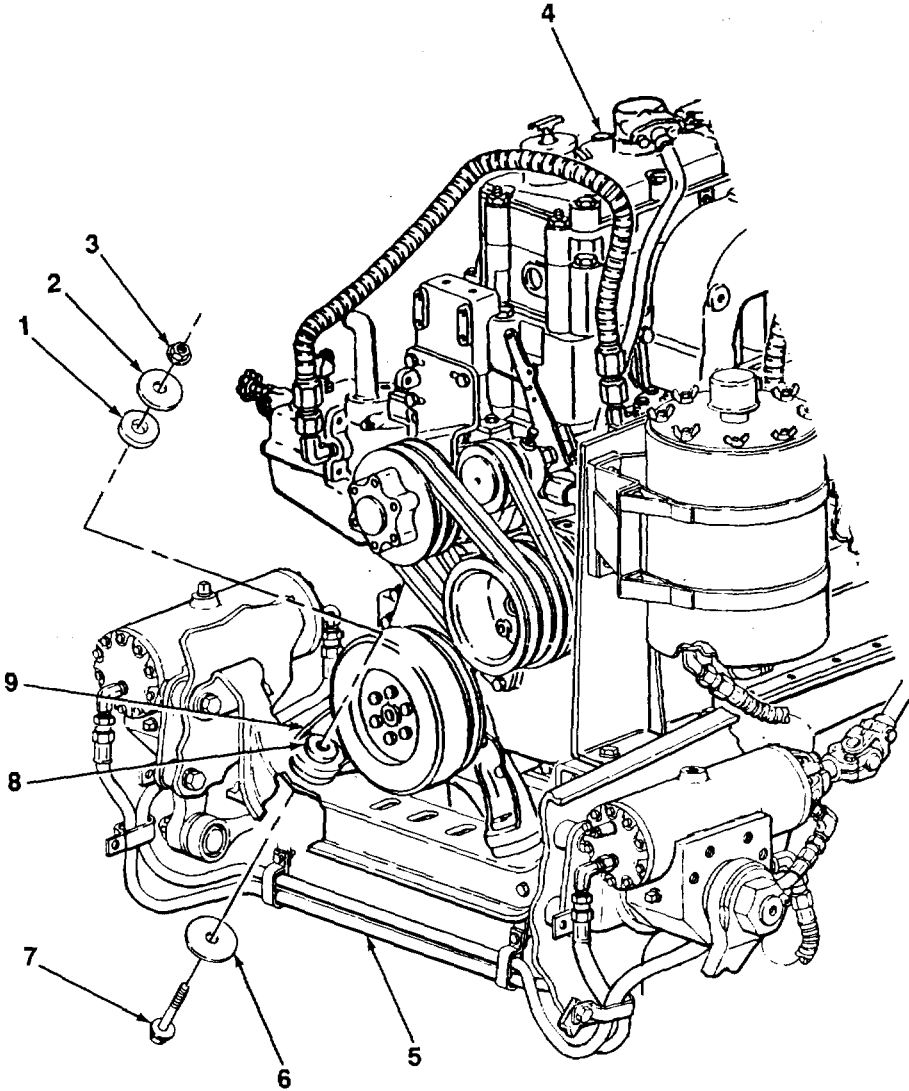

3-3. ENGINE MOUNTS REPLACEMENT (Con't)**CAUTION**

Ensure that engine mounts at front of engine are in place, or that engine is fully supported with suitable lifting device, before attempting to remove rear mounting brackets.

NOTE

Perform steps 4 through 7 to remove rear engine mounts and brackets.

4. Support rear of engine (4) with suitable lifting device.
5. Raise rear of engine (4) just enough to take weight of engine off rear engine mount upper Insulator (16).

NOTE

Perform steps 6 through 8 at left and right rear of engine.

6. Remove cotter pin (20), nut (19), washer (21), bolt (10), washer (11), Insulator (22), and upper insulator (16) from rear engine mount (23). Discard cotter pin.
7. Remove four bolts (15), lockwashers (14), washers (13), and rear engine mounting bracket (12) from engine (4). Discard lockwashers.
8. Remove four bolts (24), nuts (18), and rear engine mount (23) from frame (17).

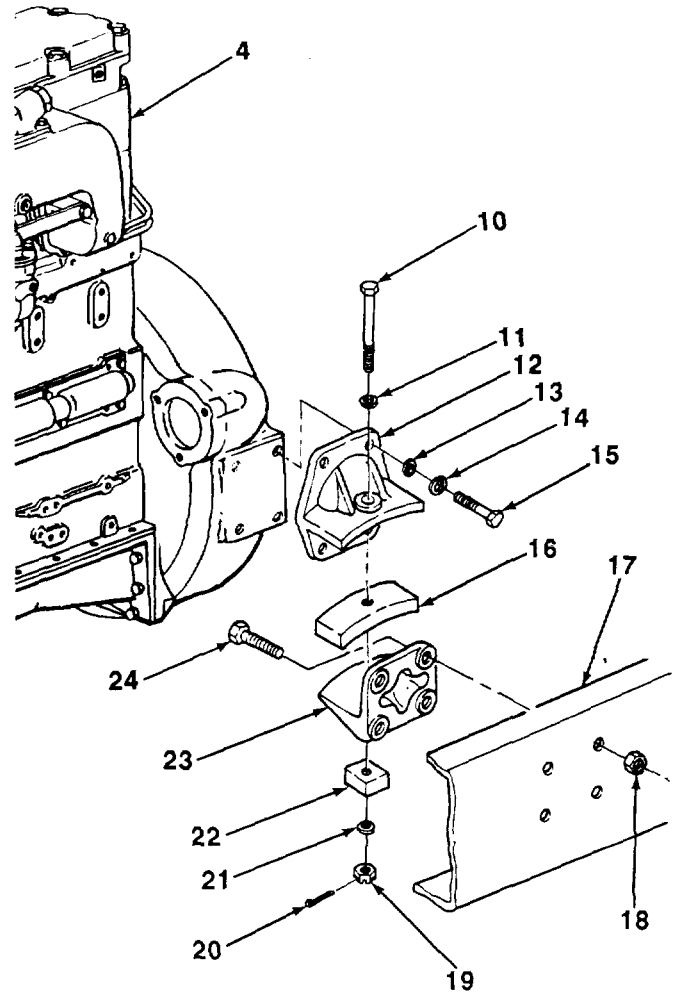
**b. INSTALLATION**

Perform steps 1 through 3 to install rear engine mounts and brackets at left and right rear of engine.

1. Install rear engine mount (23) on frame (17) with four bolts (24) and nuts (18).
2. Install rear engine mounting bracket (12) to engine (4) with four washers (13), new lockwashers (14), and bolts (15).
3. Install rear engine mounting bracket (12) to rear engine mount (23) with insulator (22), upper insulator (16), washer (11), bolt (10), washer (21), nut (14), and new cotter pin (20).
4. Remove lifting device and tighten bolts (10).

TA703656

3-3. ENGINE MOUNTS REPLACEMENT (Con't).**NOTE**

Perform steps 5 and 6 to install front engine mounts at left and right side of engine mount bracket.

5. Install washer (6), bolt (7), insulator washers (1 and 8), flatwasher (2), and new locknut (3) to front engine mount bracket (9) and crossmember (5).
6. Remove lifting device from front of engine (4) and tighten bolts (7).

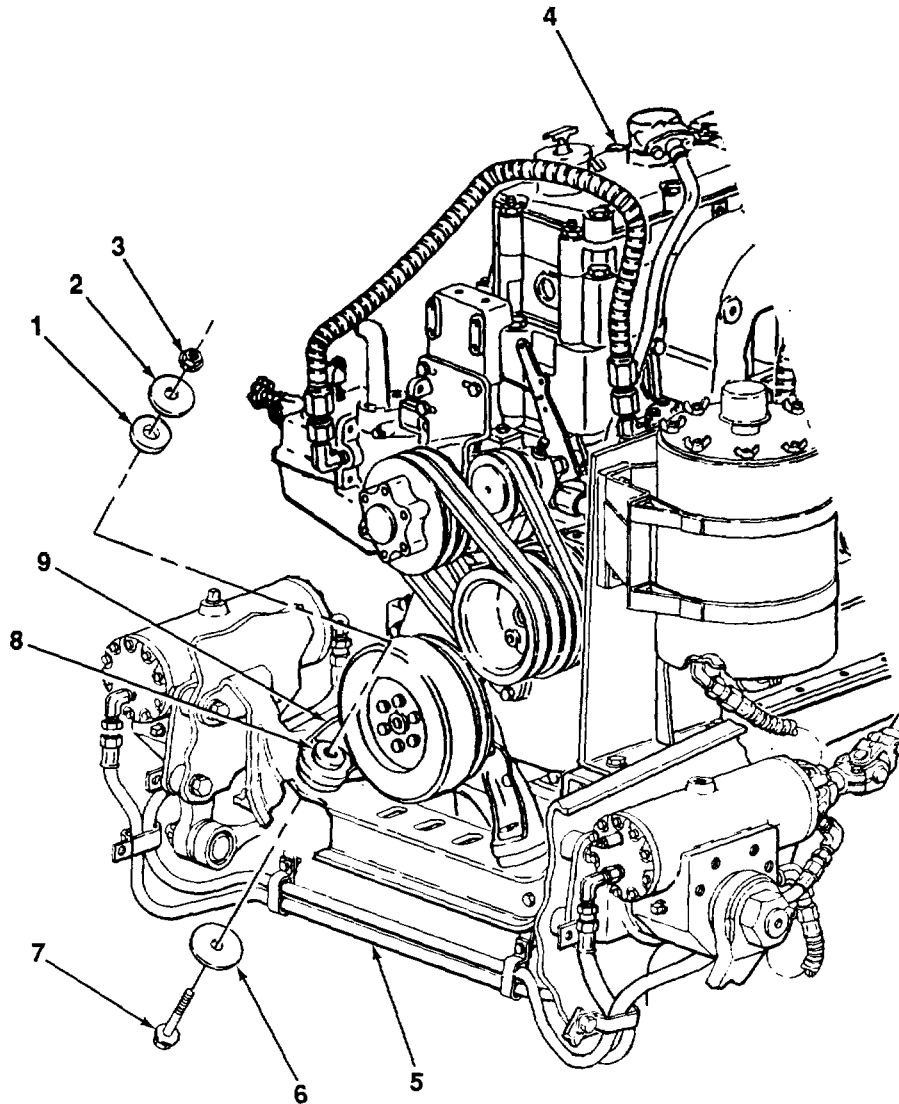
**FOLLOW-ON TASKS:**

- Install radiator (see paragraph 4-4).
- Install hood (see TM 5-3805-254-20).

TA703657

CHAPTER 4
COOLING SYSTEM MAINTENANCE

Paragraph Number	Paragraph Title	Page Number
4-1	Radiator Shutter Maintenance	4-1
4-2	Shutterstat Replacement	4-10
4-3	Radiator Shell Replacement	4-12
4-4	Radiator Maintenance	4-18
4-5	Radiator Shroud Replacement	4-36
4-6	Radiator Fan Replacement	4-37
4-7	Radiator Fan Hub Repair	4-38

4-1. RADIATOR SHUTTER MAINTENANCE.

This Task Covers:

- a. Removal
 - b. Disassembly
 - c. Assembly
 - d. Installation
-

Initial Setup:

Equipment Conditions:

* Radiator grille removed (see TM 5-3805-254-20).

Materials/Parts:

- Six rivets
- Nine lockwashers

Tools/Test Equipment:

- General mechanic's tool kit

4-1. RADIATOR SHUTT MAINTENANCE (Con't).

a. REMOVAL

- 1. Disconnect hose (1) from elbow (4) on air cylinder (2).
- 2. Remove elbow (4) and elbow (3) from air cylinder (2).

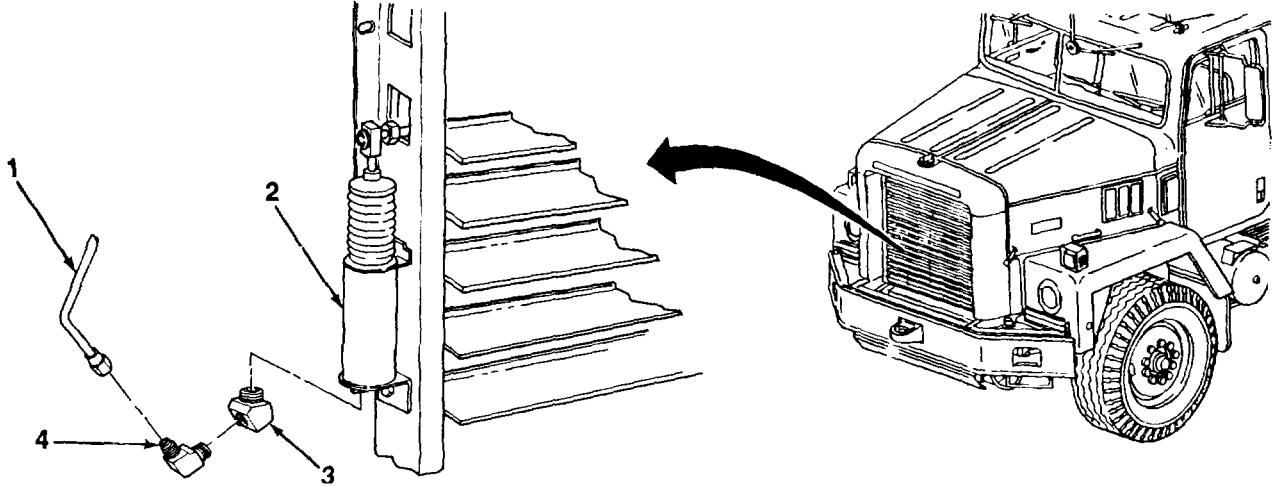

- 3. Remove eight bolts (5), lockwashers (6), and radiator shutter (8) from front of radiator shell (7). Discard lockwashers.

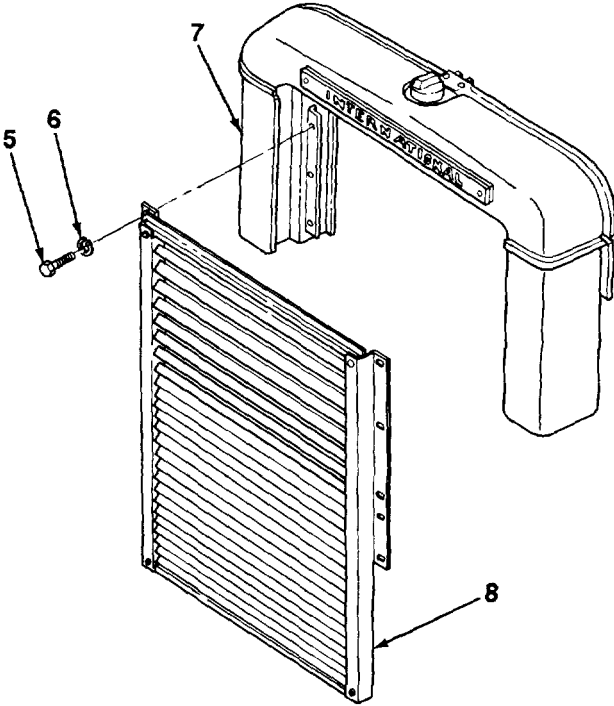

4-1. RADIATOR SHUTTER MAINTENANCE (Con't).

4. Remove screw (12) and lockwasher (13) from lower end of air cylinder (2) and radiator shutter (8). Discard lockwasher.
5. Remove retaining ring (9), two bushings (10), and air cylinder (2) from radiator shutter (8).
6. Remove end connector (11) and boot (15) from air cylinder rod (14).

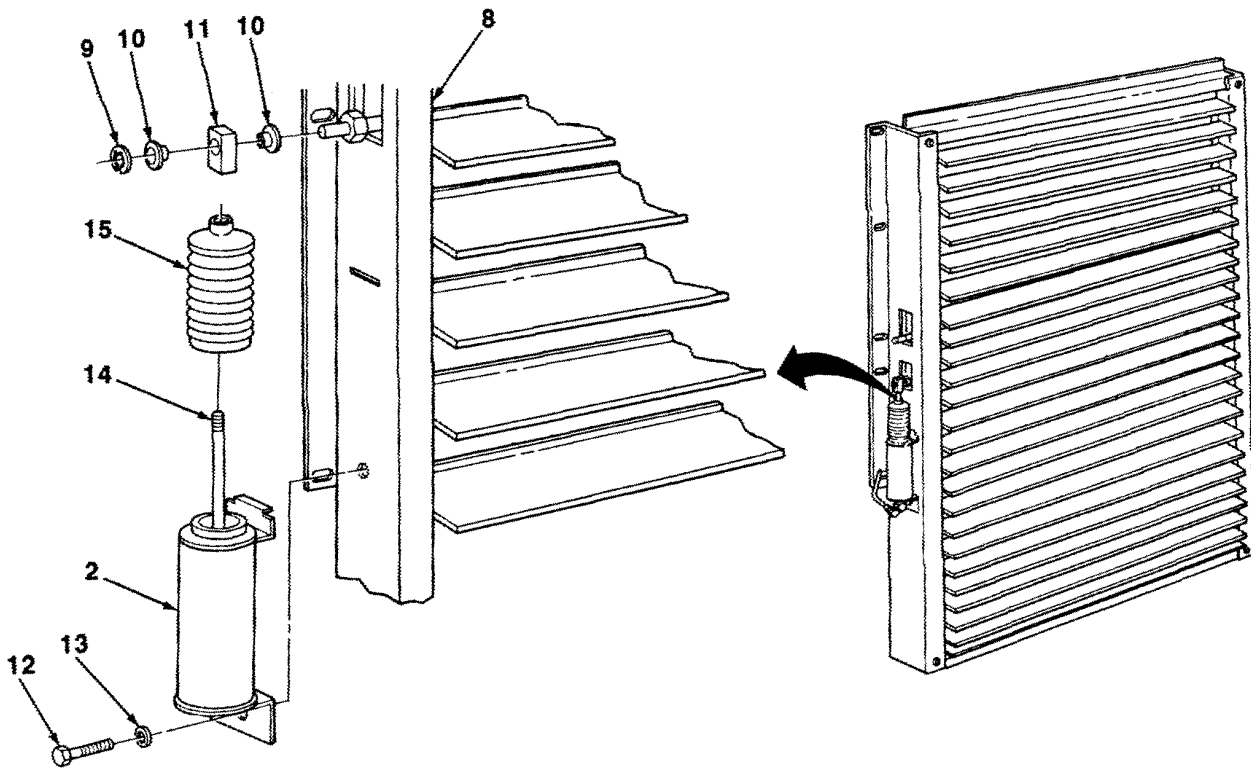

TA703639

4-1. RADIATOR SHUTTER MAINTENANCE (Con't).**b. DISASSEMBLY**

1. Remove two springs (17) from studs (16) and spring brackets (18).
2. Remove two screws (19) and bracket (20).
3. Remove four rivets (21), top member (22), and bottom member (24) from left and right members (23 and 25). Discard rivets.

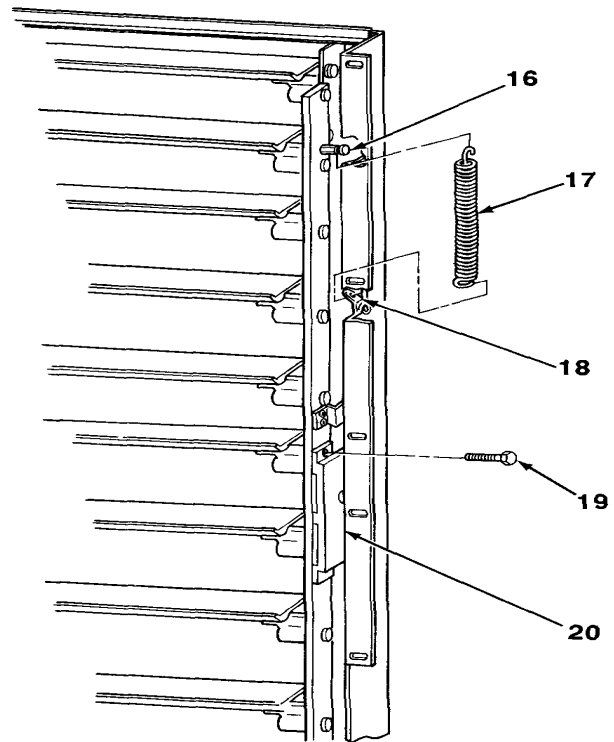
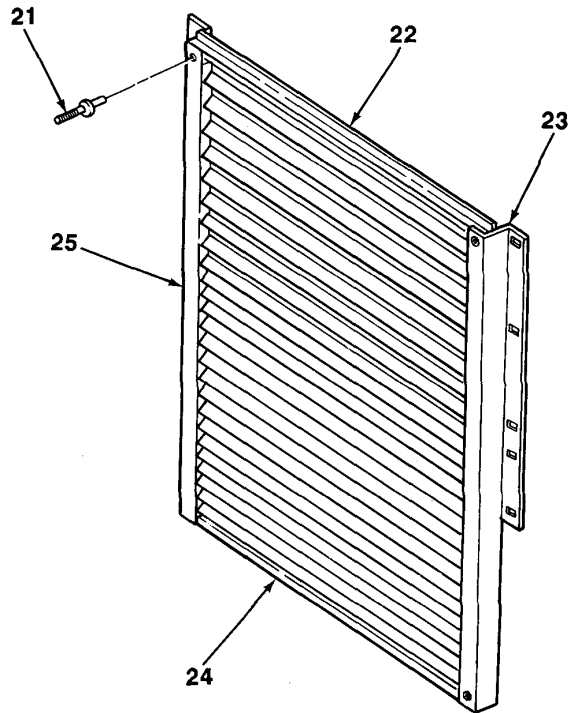

4-1. RADIATOR SHUTTER MAINTENANCE (Con't).

4. Remove two studs (16) from control bar (26).
5. Remove two rivets (27) and spring bracket (18) from left member (23). Discard rivets.
6. Remove two screws (28) and bracket (29) from control bar (26).

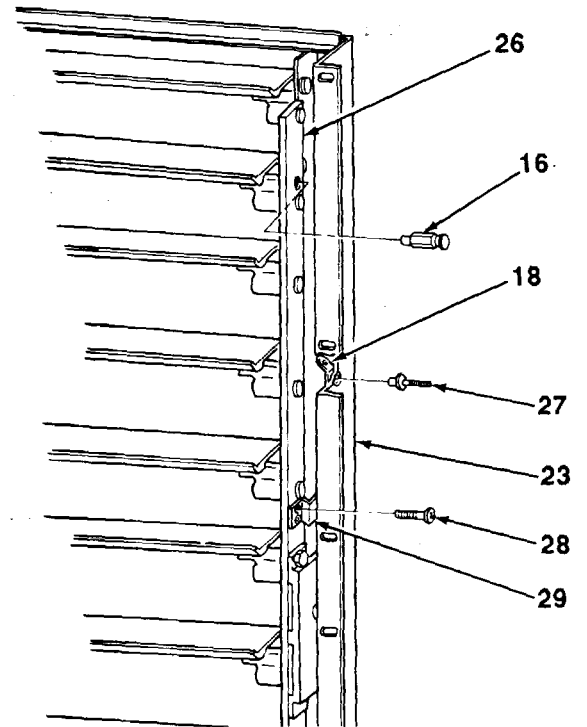

NOTE

- All shutter blades are removed in the same manner. Removal of one side is shown.
- If all shutter blades are removed, control bar, right member, and left member will be lying loose.

7. Remove retaining rings (32 and 33) from both ends of shutter blade (30).
8. Remove shutter blade (30) from left member (23).
9. Remove two bushings (31) from shutter blade (30).
10. Repeat steps 7 through 9 for remaining shutter blades (30).

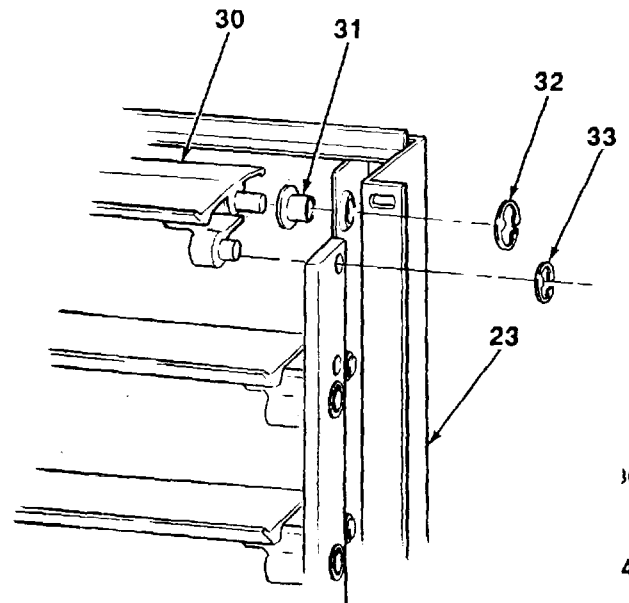

1661

4-5

TA703661

4-1. RADIATOR SHUTTER MAINTENANCE (Con't).

C. ASSEMBLY

NOTE

All shutter blades are installed in the same manner. Installation of one side is shown.

- 1. Install two bushings (31) on shutter blade (30).
- 2. Install shutter blade (30) in left member (23) with retaining rings (32 and 33) on each side.
- 3. Repeat steps 1 and 2 for remaining shutter blades (30) to be installed.

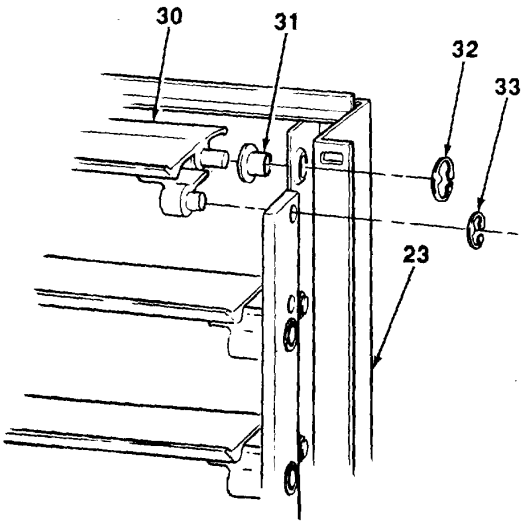

- 4. Install bracket (29) with two screws (28).
- 5. Install spring bracket (18) with two new rivets (27).
- 6. Install two studs (16) in control bar (26).

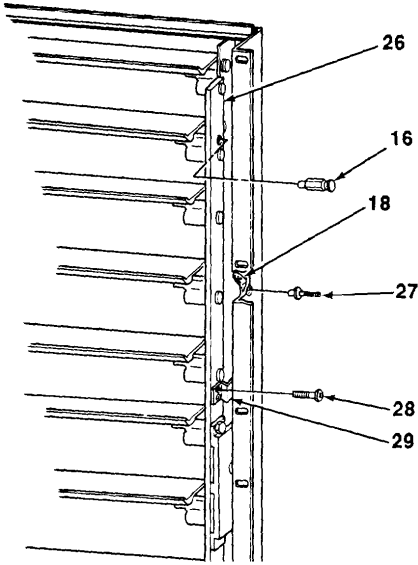

4-1. RADIATOR SHUTTER MAINTENANCE (Con't).

- 7. Install bottom member (24) and top member (22) on left and right members (23 and 25) with four new rivets (21).
- 8. Install bracket (20) with two screws (19).
- 9. Install two springs (17) on spring brackets (18) and studs (16).

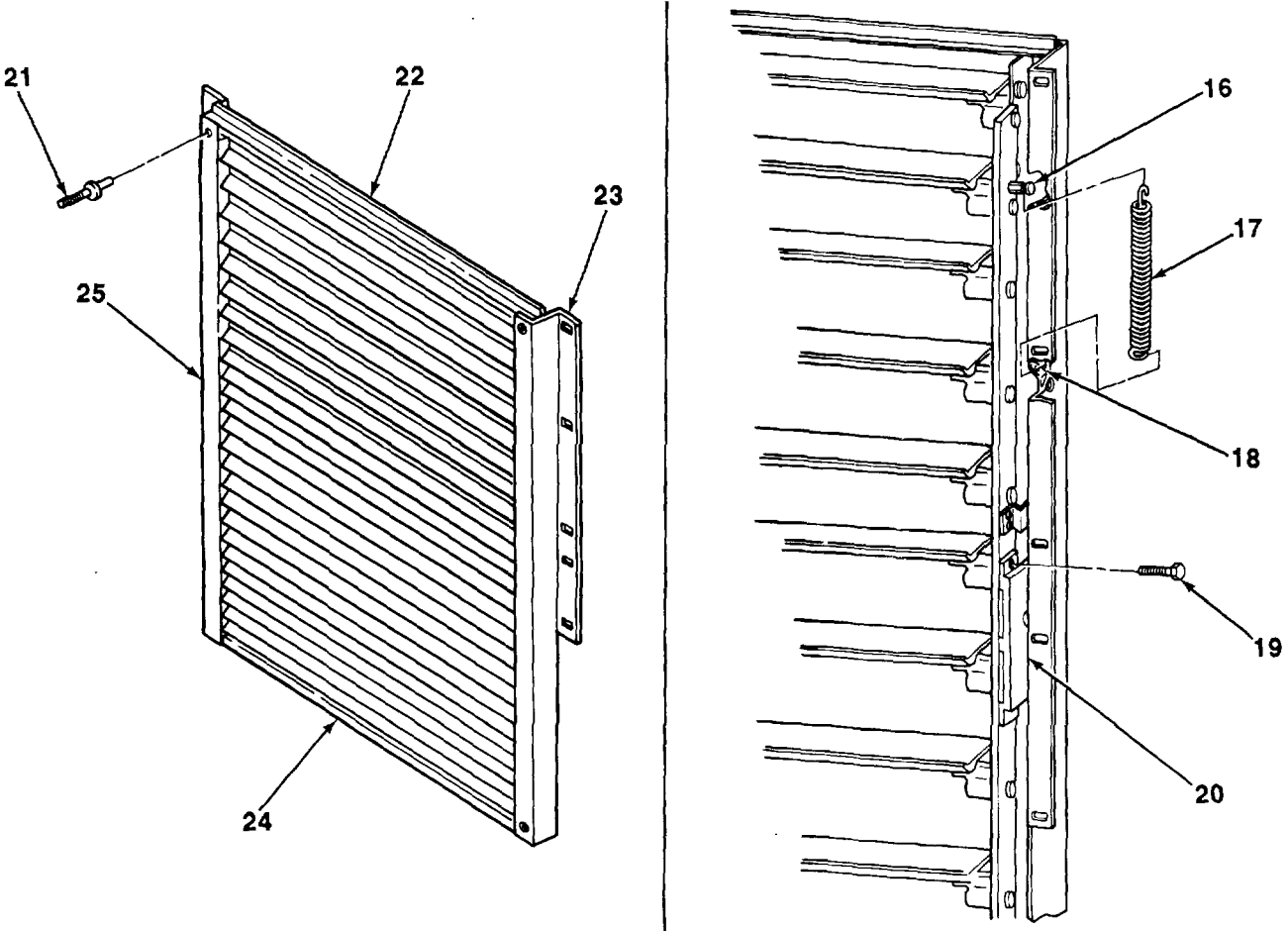

TA703663

4-1. RADIATOR SHUTTER MAINTENANCE (Con't).**d. INSTALLATION**

1. Install boot (15) and end connector (11) on air cylinder rod (14).
2. Install air cylinder (2) on radiator shutter (8) with two bushings (10) and retaining ring (9).
3. Install top of air cylinder (2) in slot on radiator shutter (8).
4. Install lower end of air cylinder (2) with new lockwasher (13) and screw (12).

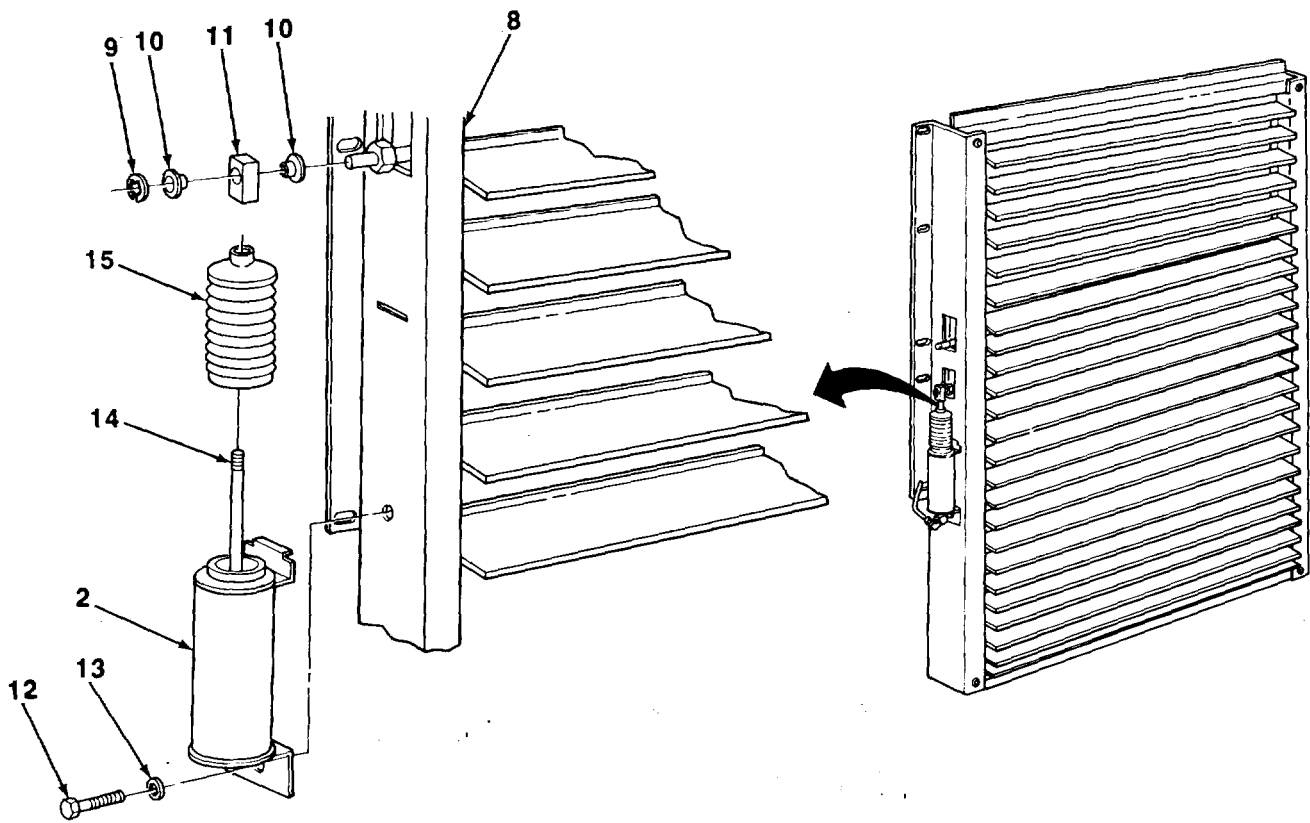

TA703664

4-1. RADIATOR SHUTTER MAINTENANCE (Con't).

5. Install radiator shutter (8) to front of radiator shell (7) with eight new lockwashers (6) and bolts (5).

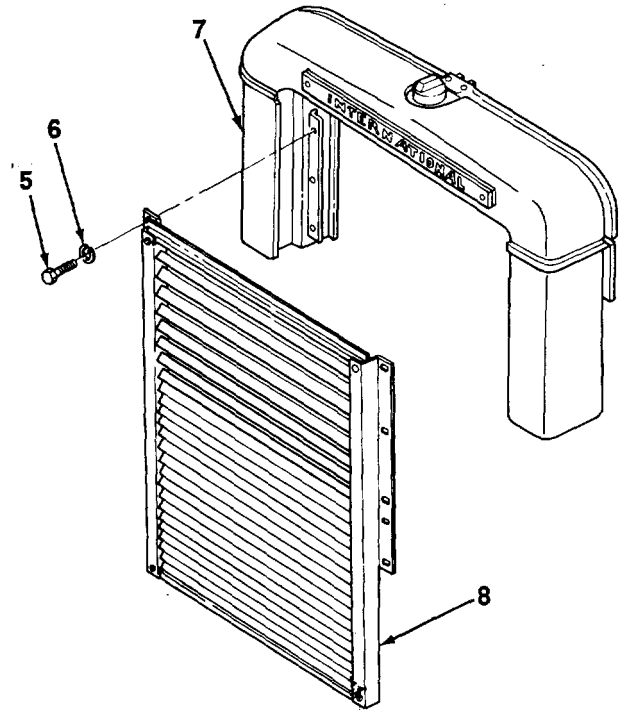

6. Connect elbow (3) and elbow (4) to air cylinder
7. Connect hose (1) to elbow (4).

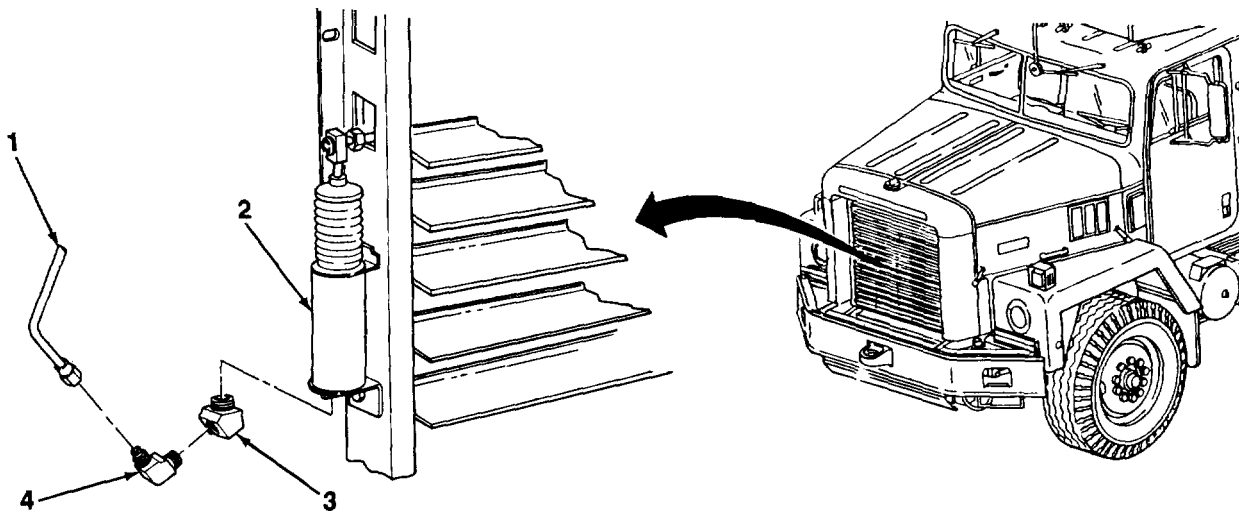

FOLLOW-ON TASKS:

- Install radiator grille (see TM 5-3805-254-20).

4-2. SHUTTERSTAT REPLACEMENT.

This Task Covers:

a. Removal

b. Installation

Initial Setup:

Equipment Conditions:

- Left hood opened (see TM 5-3805-254-10).

Tools/Test Equipment:

- General mechanic's tool kit
-

a. REMOVAL

1. Disconnect air cylinder-to-draincock hose assembly (1) from elbow (19) and connector (2).
2. Remove two screws (20), clamps (21), and air cylinder-to-draincock hose assembly (1).
3. Remove elbow (19) from pipe elbow (18).
4. Remove pipe elbow (18) from air cylinder (17).
5. Disconnect hose assembly (7) from elbow (12) and elbow (8).
6. Remove nut (10), screw (15), clamp (14), and hose assembly (7) from engine (9).
7. Remove screw (16) and extension (11) from engine (9).
8. Remove elbow (12) from air manifold (13)
9. Remove elbow (8) from check valve (6).
10. Remove check valve (6) from shutterstat (5).
11. Remove connector (2), draincock (3), and tee (4) from shutterstat (5).
12. Remove shutterstat (5) and reducer (22) from engine (9).

b. INSTALLATION

1. Install reducer (22) on engine (9).
2. Install shutterstat (5) on reducer (22).
3. Install tee (4), draincock (3), and connector (2) on shutterstat (5).
4. Install check valve (6) on shutterstat (5).
5. Install elbow (8) on check valve (6).
6. Install elbow (12) in air manifold (13).
7. Install extension (11) on engine (9) with screw (16).
8. Connect hose assembly (7) to elbow (8), and elbow (12), and install on engine with clamp (14), screw (15), and nut (10).
9. Install pipe elbow (18) on air cylinder (17).

4-2. SHUTTERSTAT REPLACEMENT (Con't).

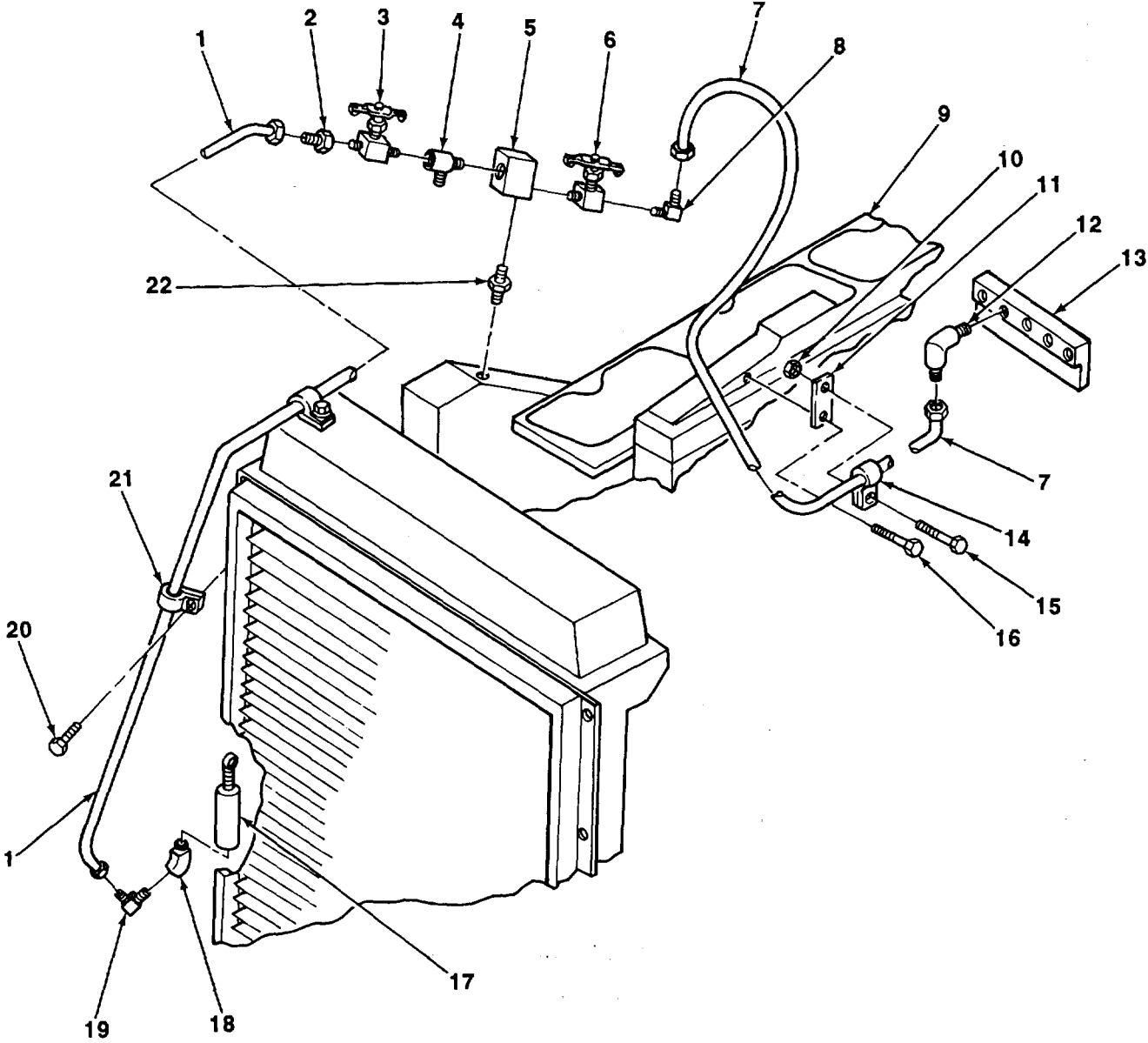

- 10. Install elbow (19) on pipe elbow (18).
- 11. Connect air cylinder-to-draincock hose assembly (1) to elbow (19) and connector (2), and Install with two clamps (21) and screws (20).

FOLLOW-ON TASKS:

- Close left hood (see TM 5-3805-254-10).

4-3. RADIATOR SHELL REPLACEMENT.

This Task Covers:

a. Removal

b. Installation

Initial Setup:

Equipment Conditions:

- Hood removed (see TM 5-3805-254-20).
- Hood latches removed (see TM 5-3805-254-20).
- Water filter hose removed (see TM 5-3805-254-20).
- Water filter removed (see TM 5-3805-254-20).
- Radiator shutter removed (see paragraph 4-1).

Tools/Test Equipment:

- General mechanic's tool kit

Materials/Parts:

- Thirty lockwashers

Personnel Required: Two

References:

- TM 9-237

a. REMOVAL

1. Remove eight screws (6) and lockwashers (7) holding radiator shell (1) to rear of radiator. Discard lockwashers.
2. Remove radiator cap (2).
3. Remove two bolts (3), lockwashers (4), and nuts (5) from top of radiator shell (1) and bracket. Discard lockwashers.
4. Remove radiator shell (1) from vehicle.

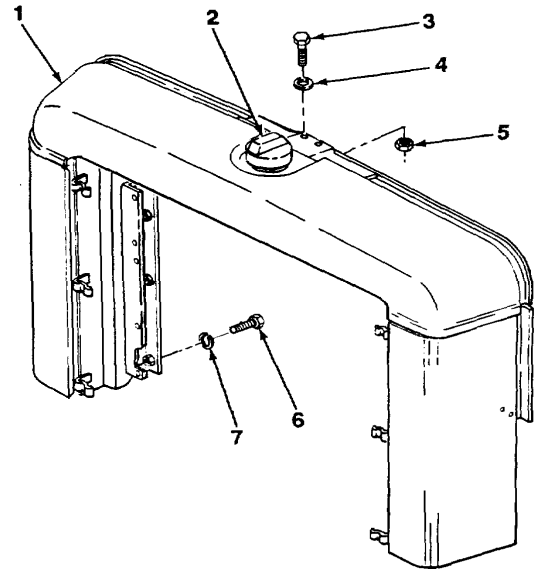

TA703667

4-3. RADIATOR SHELL REPLACEMENT (Con't).**NOTE**

Perform steps 5 and 6 at left and right side of radiator shell.

5. Remove four nuts (11), screws (10), lockwashers (9), washers (8), and two supports (12) from radiator shell (1) and side panel (16). Discard lockwashers.
6. Remove three nuts (17), screws (13), lockwashers (14), washers (15), and side panel (16). Discard lockwashers.

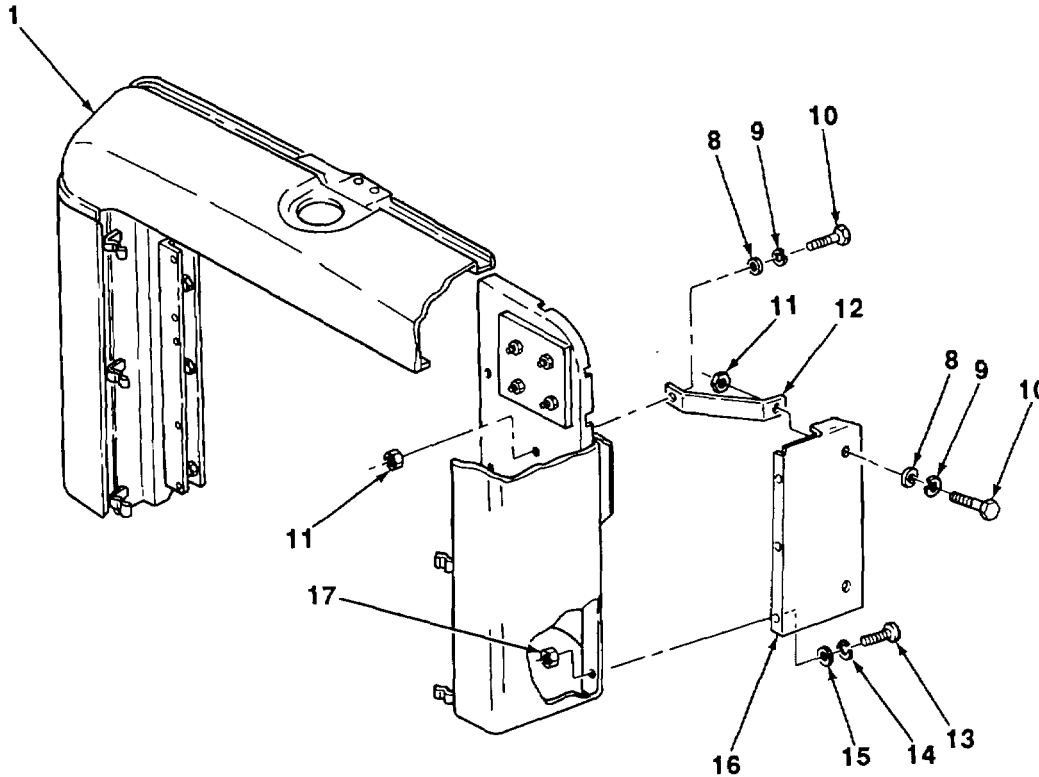

TA703668

4-3. RADIATOR SHELL REPLACEMENT (Con't).

7. Remove screw (20) and washer (21) from each of two seals (18).
8. Remove 18 plastic retainers (19) and two seals (18) from radiator shell (1).

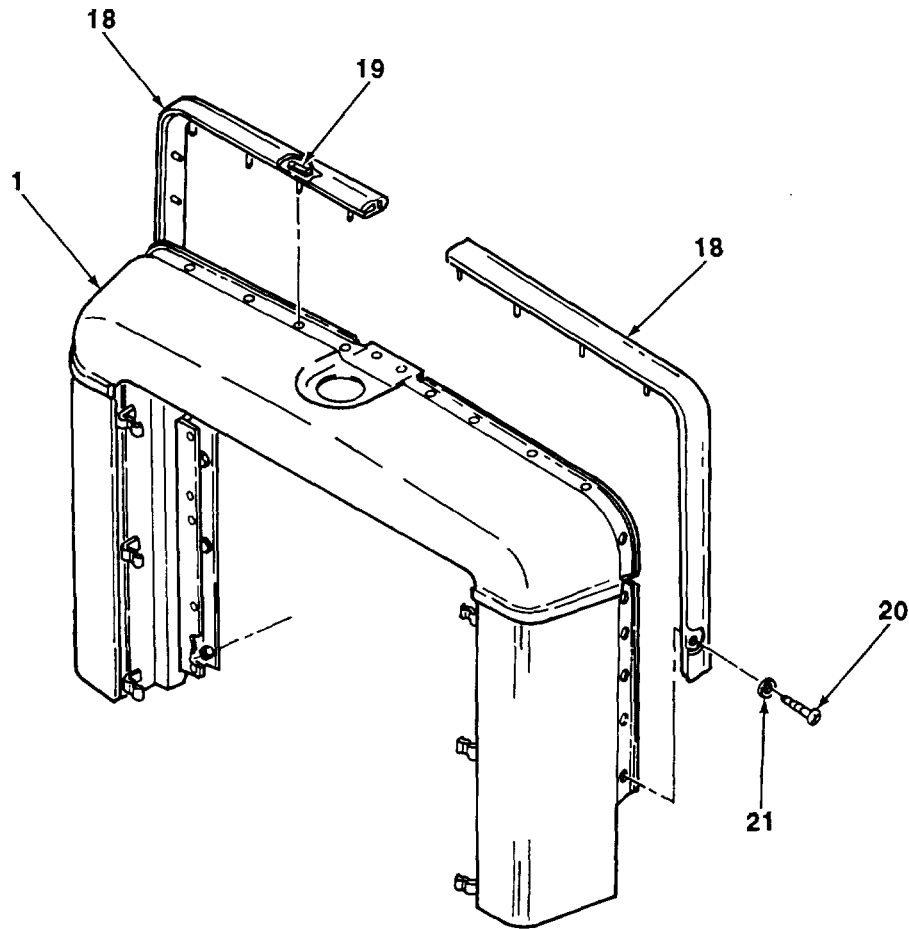

NOTE

Panels, shrouds, and reinforcement panel are spot welded to each other. Remove only if damaged.

9. Break welds to remove left and right filler panels (23 and 26) ;from left and right shrouds (25 and 27) and reinforcement panel (22).
10. Break welds to remove left and right shrouds (25 and 27) from front lower left and front lower right panels (24 and 28) and reinforcement panel (22).
11. Break welds to remove front lower left or front lower right panels (24 or 28) from front reinforcement panel (22).

TA703669

4-3. RADIATOR SHELL REPLACEMENT (Con't).

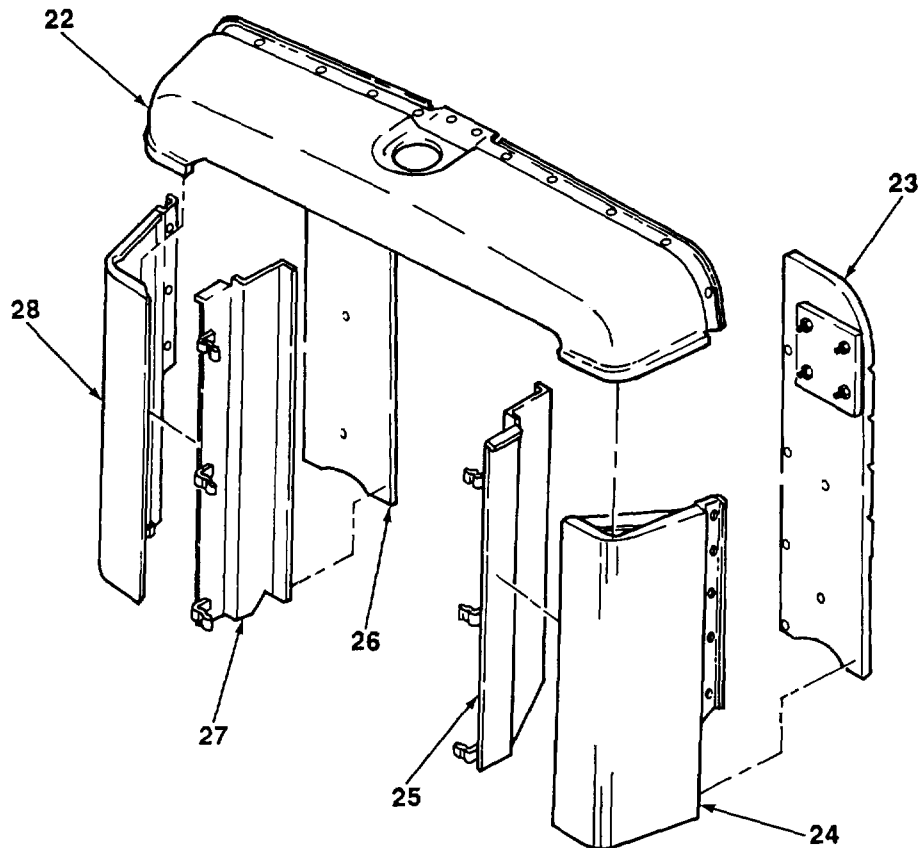

b. INSTALLATION

NOTE

Panel, shrouds, and reinforcement panel are spot welded to each other. Spot weld the same number of places as was removed. Refer to TM 9-237 for instructions on welding.

1. Install front lower left or front lower right panels (24 or 28) to reinforcement panel (22) with welds.
2. Install left and right shrouds (25 and 27) to front lower left and front lower right panels (24 and 28) and reinforcement panel (22) with welds.
3. Install left and right filler panels (23 and 26) to left and right shrouds (25 and 27) and reinforcement panel (22) with welds.

TA703670

4-3. RADIATOR SHELL REPLACEMENT (Con't).

4. Install two seals (18) to radiator shell (1) with 18 plastic retainers (19).
5. Install washer (21) and screw (20) to each of two seals (18).

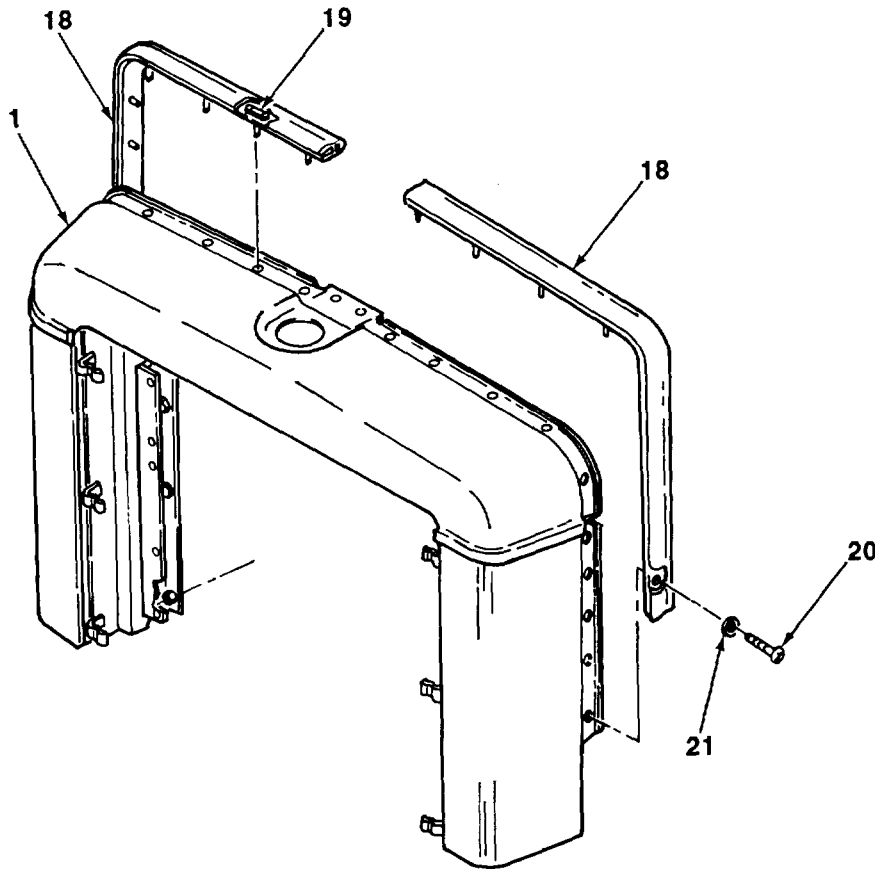
**NOTE**

Perform steps 6 and 7 at left and right side of radiator shell.

6. Install side panel (16) to radiator shell (1) with three washers (15), new lockwashers (14), screws (13), and nuts (17).
7. Install two supports (12) to radiator shell (1) and side panel (16) with four washers (8), new lockwashers (9), screws (10), and nuts (11).

TA703671

4-3. RADIATOR SHELL REPLACEMENT (Con't).

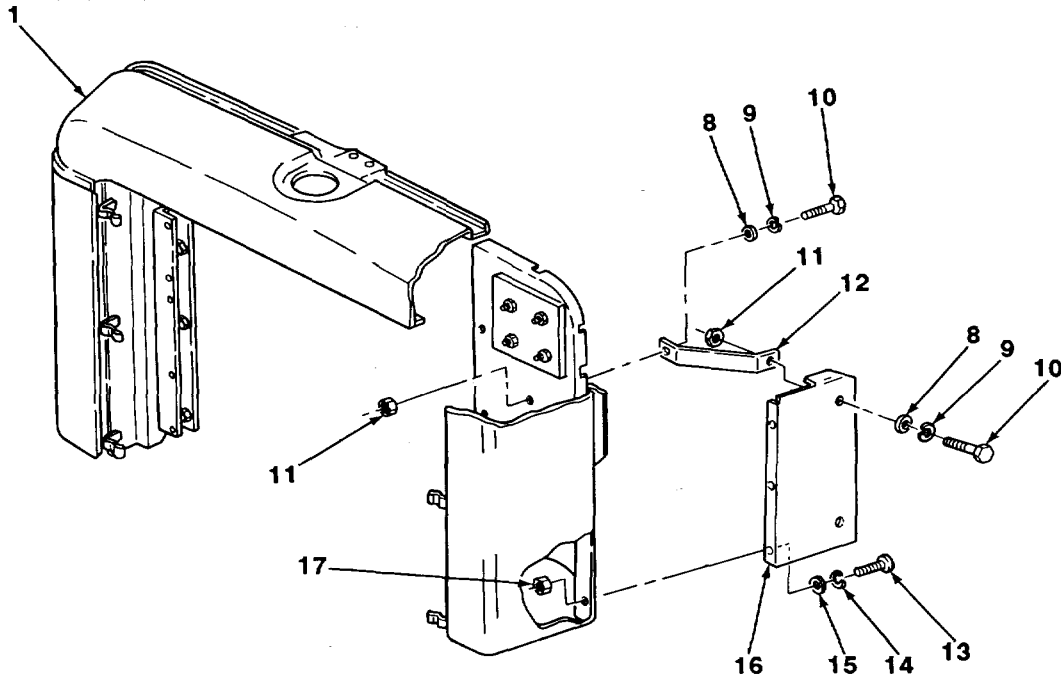

8. Install radiator shell (1) to rear of radiator with eight screws (6) and new lockwashers (7).
9. Install top of radiator shell (1) to bracket with two nuts (5), new lockwashers (4), and bolts (3).
10. Install radiator cap (2).

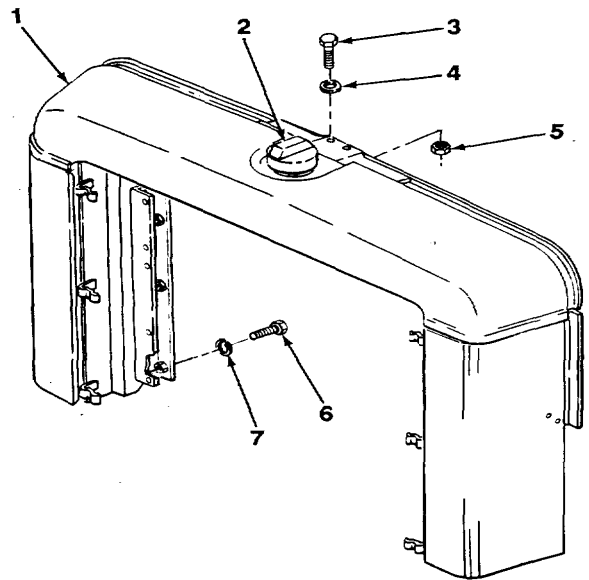

FOLLOW-ON TASKS:

- * Install radiator shutter (see paragraph 4-1).
- * Install water filter (see TM 5-3805-254-20).
- * Install water filter hose (see TM 5-3805-254-20).
- * Install hood latches (see TM 5-3805-254-20).
- * Install hood (see TM 5-3805-254-20).

4-4. RADIATOR MAINTENANCE.

This Task Covers:

- | | |
|----------------|-----------------|
| a. Removal | d. Assembly |
| b. Disassembly | e. Installation |
| c. Repair | |

Initial Setup:

Equipment Conditions:

- * Radiator outlet hose removed (see TM 5-3805-254-20)
- * Radiator inlet hose removed (see TM 5-3805-254-20)
- * Radiator hose removed (see TM 5-3805-254-20)
- * Radiator vent hose and deaeration hose removed (see TM 5-3805-254-20)
- * Water filter hose disconnected (see TM 5-3805-254-20)
- * Radiator shell removed (see paragraph 4-3)

Materials/Parts:

- * Sealant compound (Item 19, Appendix B)
- * Six gaskets
- * Six locknuts
- * 125 lockwashers

Personnel Required: Two

References:

- * TM 750-254

Tools/Test Equipment:

- * General mechanic's tool kit
- * Overhead lifting device

a. REMOVAL

1. Attach lifting device to top of radiator assembly (1).
2. Use lifting device to raise radiator assembly (1) enough to take weight of radiator assembly off channel (4).
3. Remove two nuts (8), special washers (7), bolts (2), spacers (6), and insulators (5) from two mounting brackets (3).

4-4. RADIATOR MAINTENANCE (Con't).

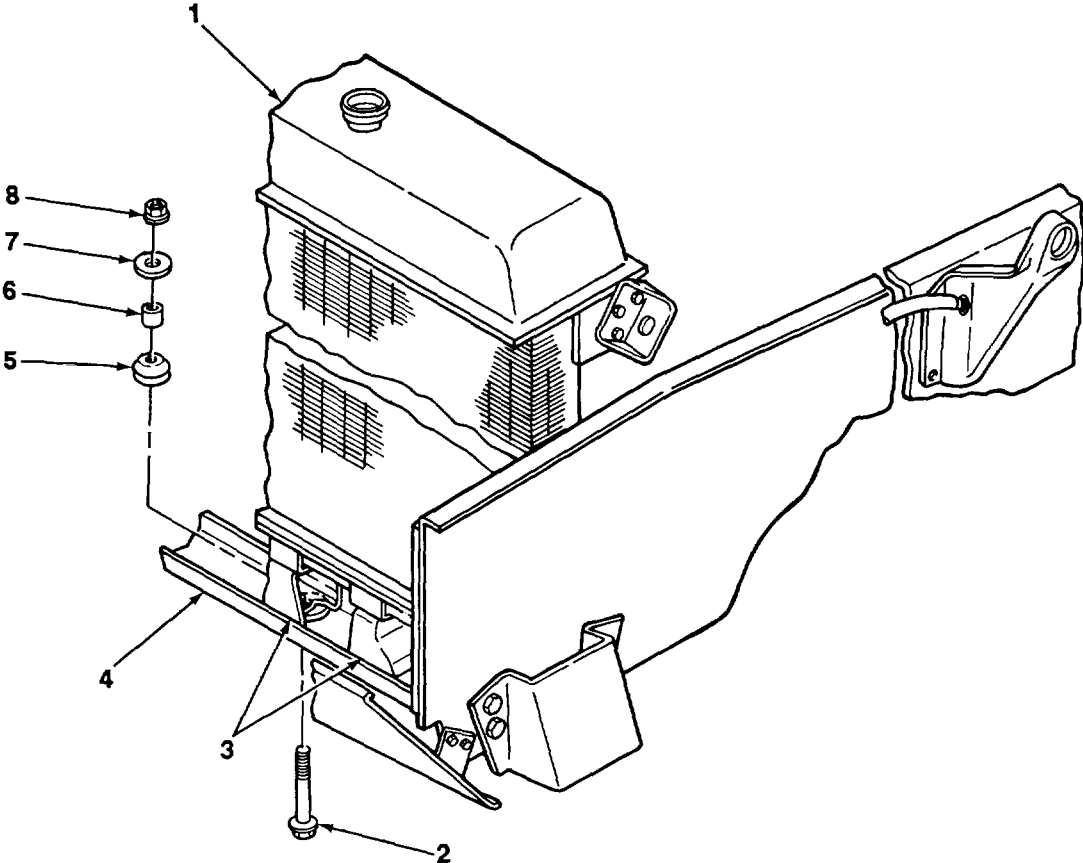

TA703673

4-4. RADIATOR MAINTENANCE (Con't).

4. Remove two nuts (13), lockwashers (12), and screws (11) from right and left stabilizer rods (9), and radiator assembly (1). Discard lockwashers.

NOTE

Perform steps 5 through 8 only if stabilizer rod, parts of stabilizer rod, or stabilizer rod brackets are damaged.

5. Remove one nut (14), washer (15), bushing (16), and right or left stabilizer rod (9) from right or left bracket (20).
6. Remove spacer (17), bushing (16), washer (15), and nut (14) from stabilizer rod (9).
7. Remove rod end (10) from right or left stabilizer rod (9).
8. Remove two screws (18), lockwashers (19), and right or left bracket (20). Discard lockwashers.

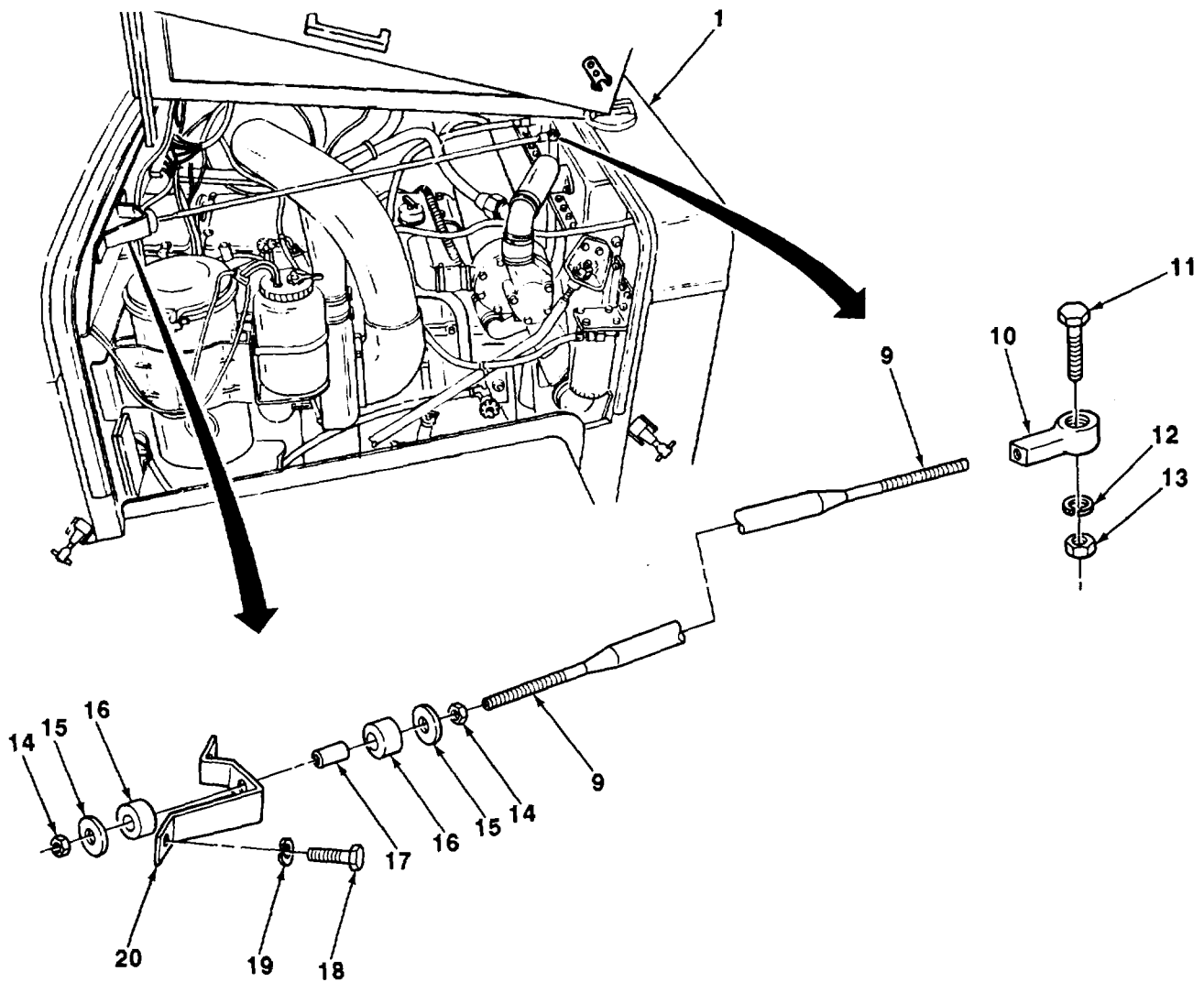

TA703674

4-4. RADIATOR MAINTENANCE (Con't).**WARNING**

Radiator assembly is heavy and must be supported as stabilizer rods are disconnected to prevent falling. Use care when handling to avoid injury.

NOTE

Perform step 9 at each side of radiator.

9. Remove nut (21), lockwasher (22), washer (23), mount (24), and bushing (25) to disconnect stabilizer rod (27) from bracket (26). Discard lockwasher.
10. Remove radiator assembly (1) from vehicle and move to safe work area. Remove lifting device.
11. Remove radiator shroud (see paragraph 4-5).

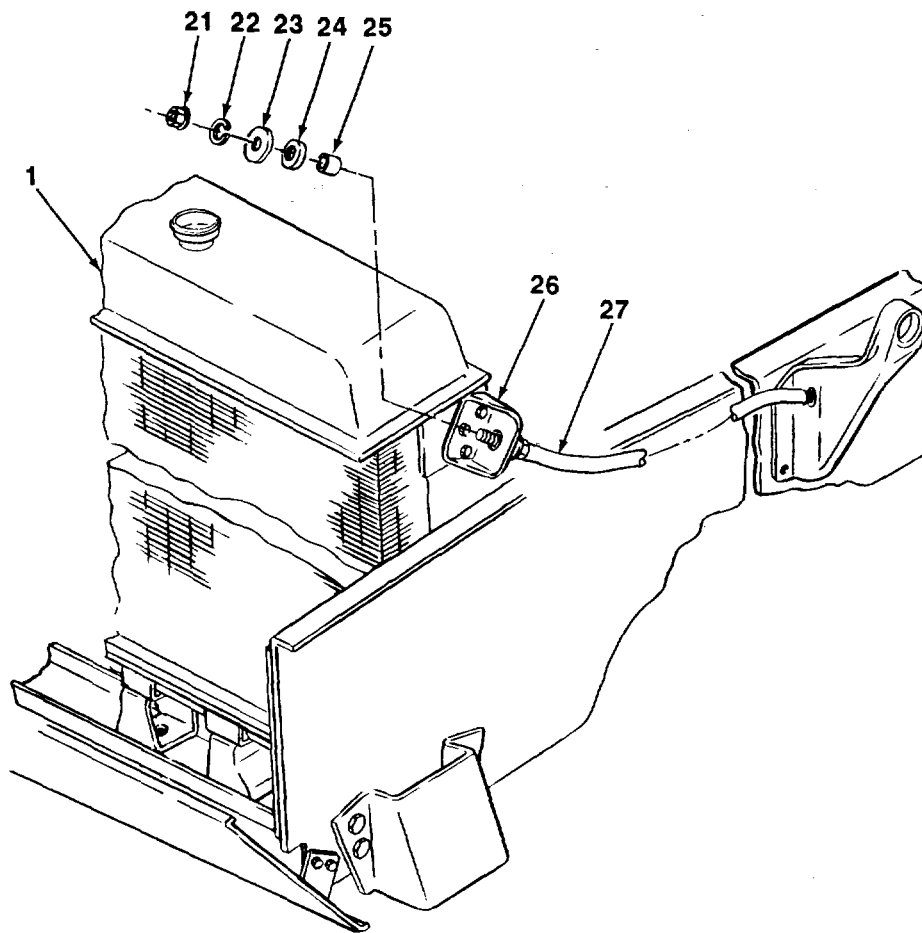

TA703675

4-4. RADIATOR MAINTENANCE (Con't).

NOTE

Perform steps 12 and 13 for left and right stabilizer rods only if stabilizer rods or mounting parts are damaged.

12. Remove remaining mount (28), washer (29), lockwasher (30), and nut (31), from end of stabilizer rod (27). Discard lockwasher.
13. Remove two nuts (32), lockwashers (33), washers (34), mounts (35), and bushing (36) at other end of stabilizer rod (27). Remove stabilizer rod from bracket (37). Discard lockwashers.

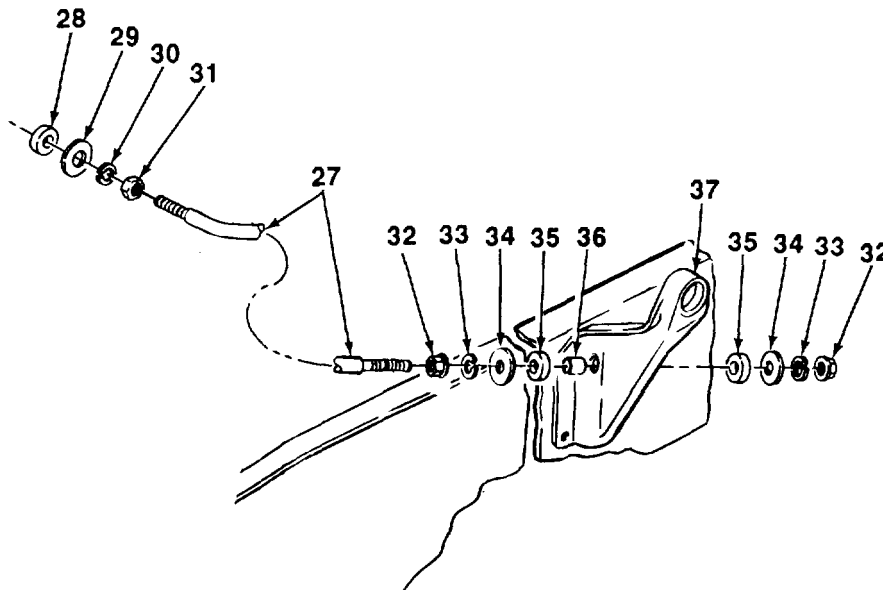

14. Remove four screws (41), lockwashers (40), two mounting brackets (3), four bushings (39), and two spacers (38) from radiator assembly (1). Discard lockwashers.

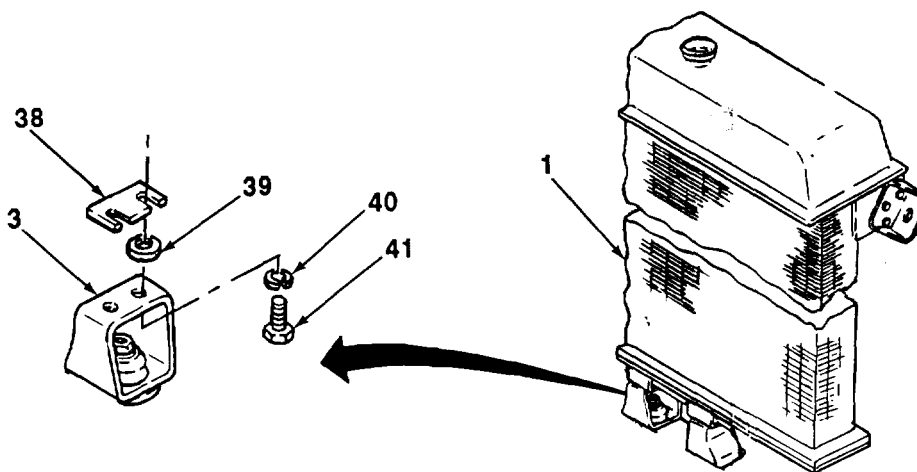

4-4. RADIATOR MAINTENANCE (Con't).

15. Remove three locknuts (45), screws (42), and bracket (26) from left member (43). Discard locknuts.
16. Repeat step 15 for right member (44).

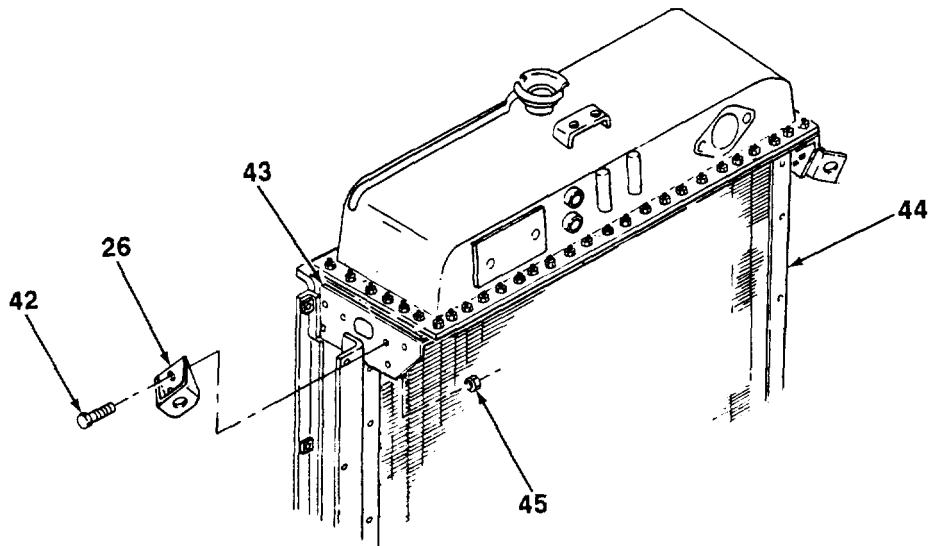

TA703677

4-4. RADIATOR MAINTENANCE (Con't).

b. DISASSEMBLY

NOTE

Screws vary in length. Note location of short screws and screws removed when radiator shell was removed (see paragraph 4-3).

1. Remove 54 nuts (47), lockwashers (48), and screws (53) holding upper tank (46) to radiator (51). Discard lockwashers.

NOTE

Note position of upper tank and radiator for assembly.

2. Remove upper rear bar (52), upper tank (46), gasket (49), and plate (50) from radiator (51). Discard gasket.

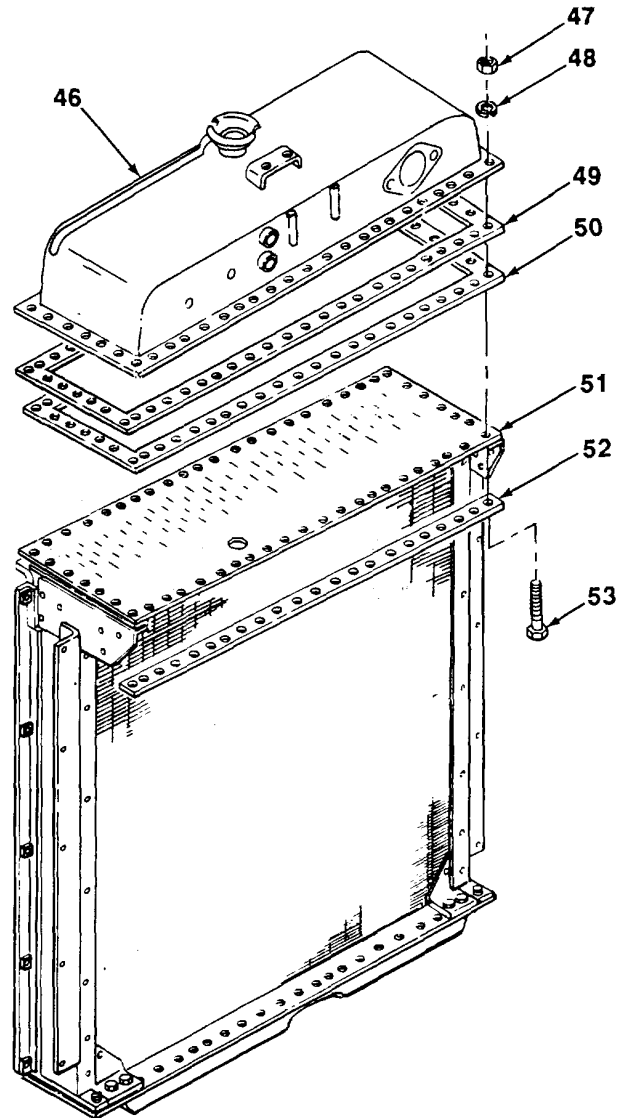

TA703678

4-4. RADIATOR MAINTENANCE (Con't).

3. Remove two screws (56), plate (55), and two gaskets (54) from upper tank (46). Discard gaskets.

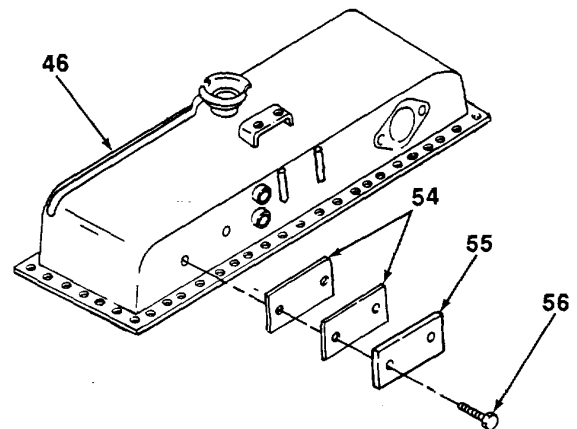

4. Remove two nuts (57) and washer (58) from each of two brace rods (59).
5. Remove two screws (61), washers (60), and two brace rods (59).

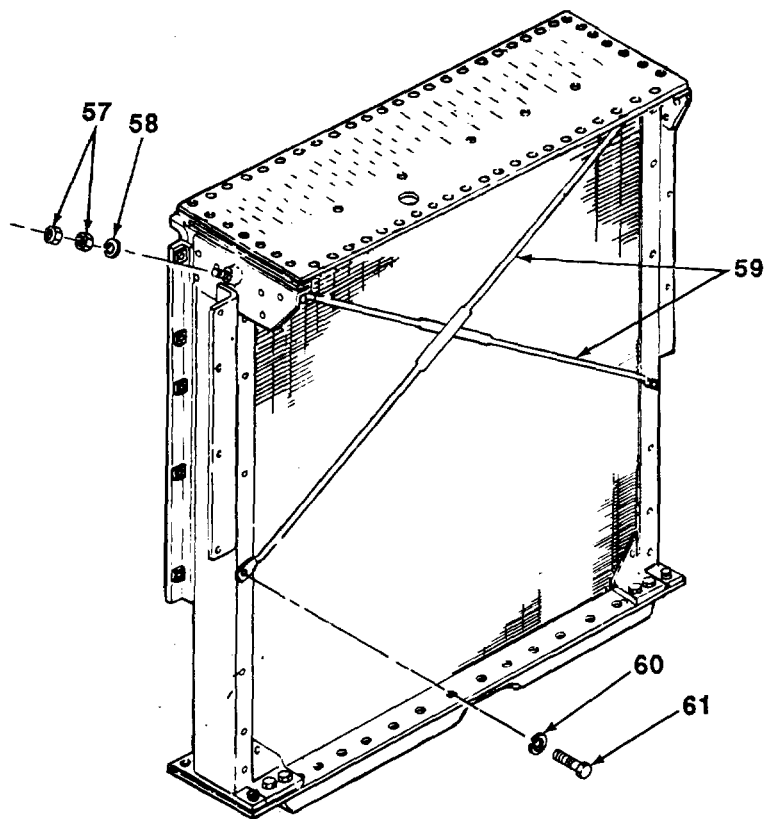

4-4. RADIATOR MAINTENANCE (Con't).

6. Remove 36 nuts (69), lockwashers (68), screws (65), and two bottom bars (76) from bottom of radiator (51). Discard lockwashers.

NOTE

Note position of lower tank and radiator for assembly.

7. Remove eight screws (74), lockwashers (75), lower tank (67), left member (43), right member (44), and gasket (66). Discard lockwashers and gasket.
8. Remove five screws (64), lockwashers (63), and bar (62) from radiator (51). Discard lockwashers.
9. Remove four screws (72), lockwashers (71), outlet cover (73), and two gaskets (70) from lower tank (67). Discard lockwashers and gaskets.

c. REPAIR

Refer to TM 750-254 for Instructions on repair of radiator.

d. ASSEMBLY

1. Apply thin coat of sealant compound to surfaces of two new gaskets (70).
2. Install two new gaskets (70) and outlet cover (73) to lower tank (67) with four new lockwashers (71) and screws (72).
3. Install bar (62) to radiator (51) with five new lockwashers (63) and screws (76).
4. Apply thin coat of sealant compound to both surfaces of new gasket (64).
5. Install left member (43), right member (44), new gasket (66), and lower tank (67) to radiator (51) with eight new lockwashers (95) and screws (74).
6. Install two bottom bars (76) to radiator (51) with 36 screws (65), new lockwashers (68), and nuts (69).

4-4. RADIATOR MAINTENANCE (Con't).

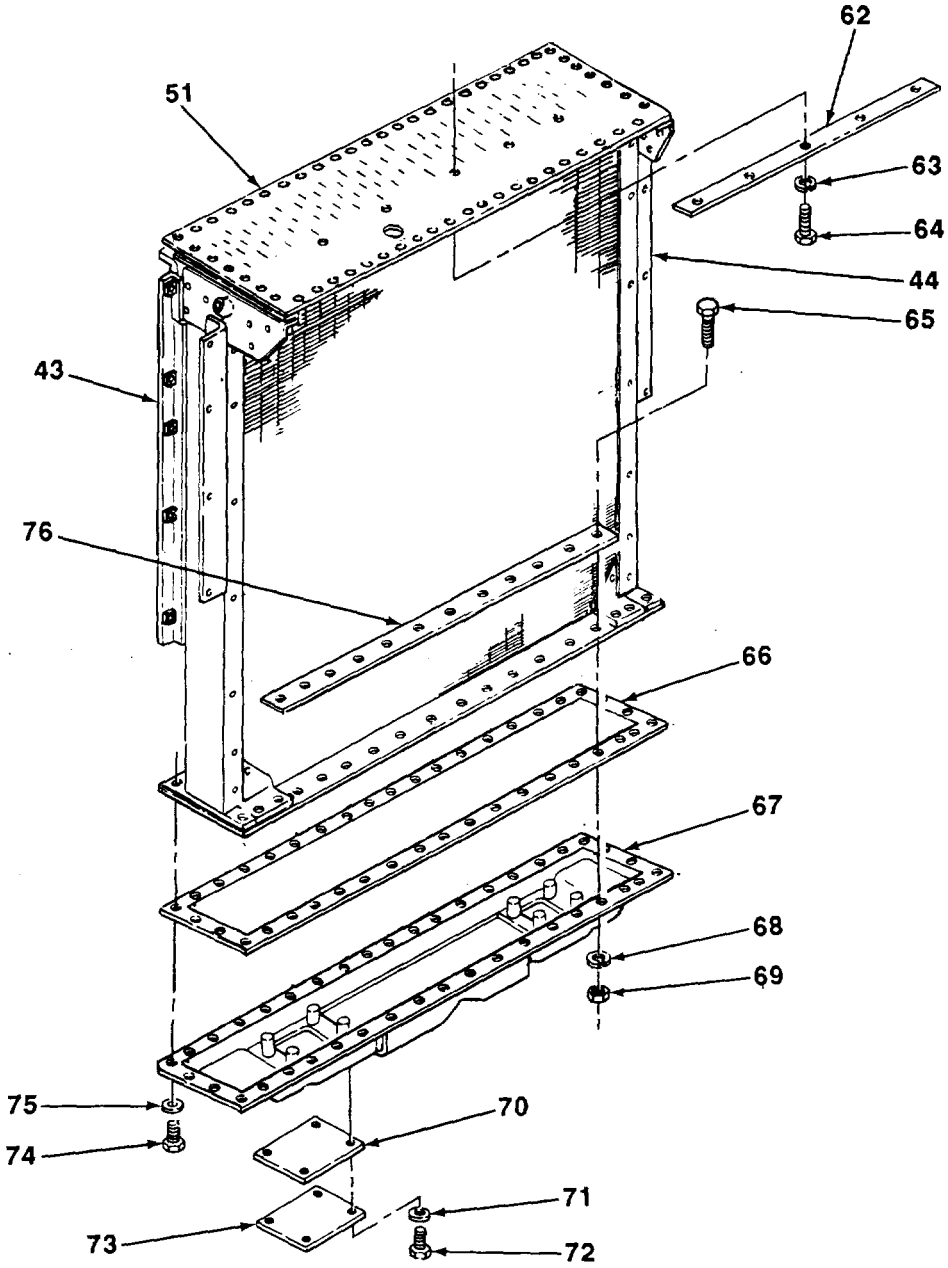

TA703680

4-4. RADIATOR MAINTENANCE (Con't).

- 7. Position threaded ends of two brace rods (59) through hole in left member (43) and right member (44).
- 8. Install other end of each brace rod (59) with two washers (60) and screws (61).
- 9. Loosely Install washer (58) and two nuts (57) to each brace rod (59).

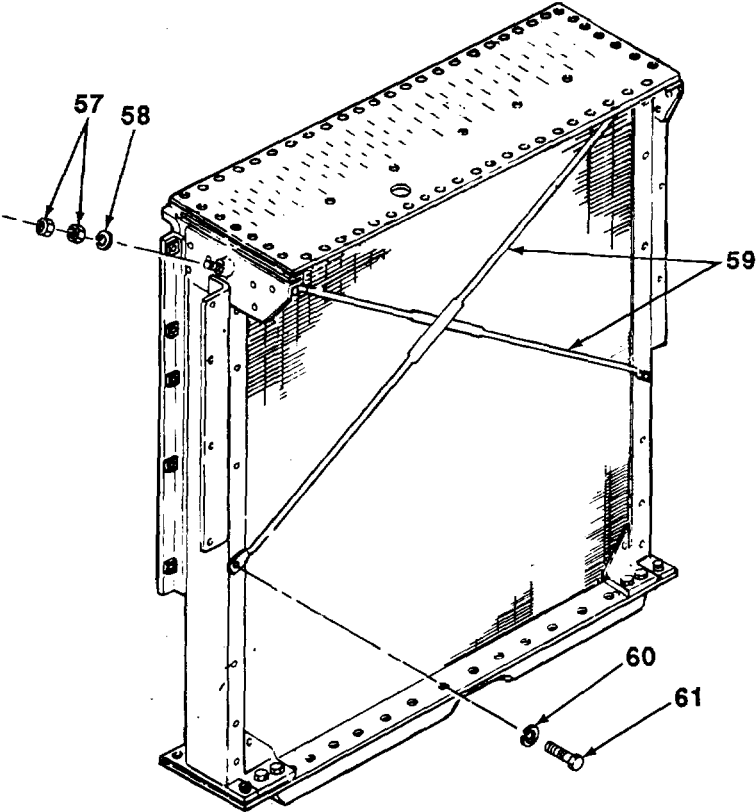

- 10. Apply thin coat of sealant compound to surfaces of two new gaskets (54).
- 11. Install two new gaskets (54) and plate (55) to upper tank (46) with two screws (56).

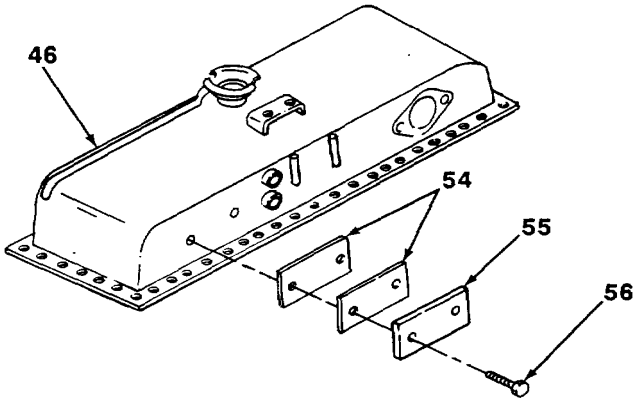

4-4. RADIATOR MAINTENANCE (Con't).

12. Apply thin coat of sealant compound to both surfaces of new gasket (49).
13. Install new gasket (49), plate (50), upper tank (46), and upper rear bar (52) to top of radiator (51).

NOTE

Install short screws in location noted during disassembly.

14. Install 54 screws (53), new lockwashers (48), and nuts (47).

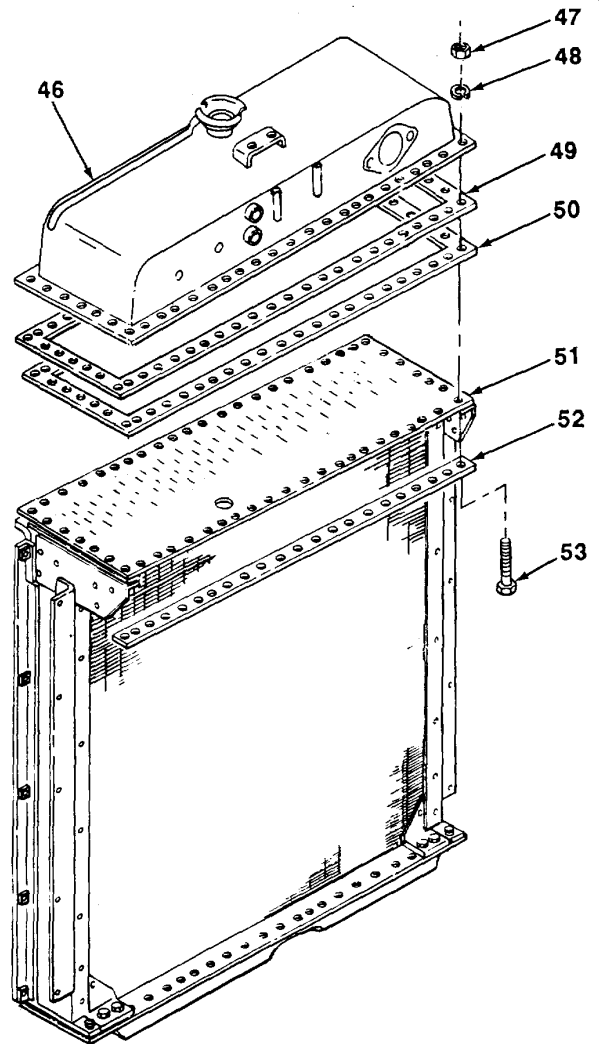

TA03682

4-4. RADIATOR MAINTENANCE (Con't).

e. INSTALLATION I

- 1. Install bracket (26) to left member (43) with three screws (42) and new locknuts (45).
- 2. Repeat step 1 for right member (44).

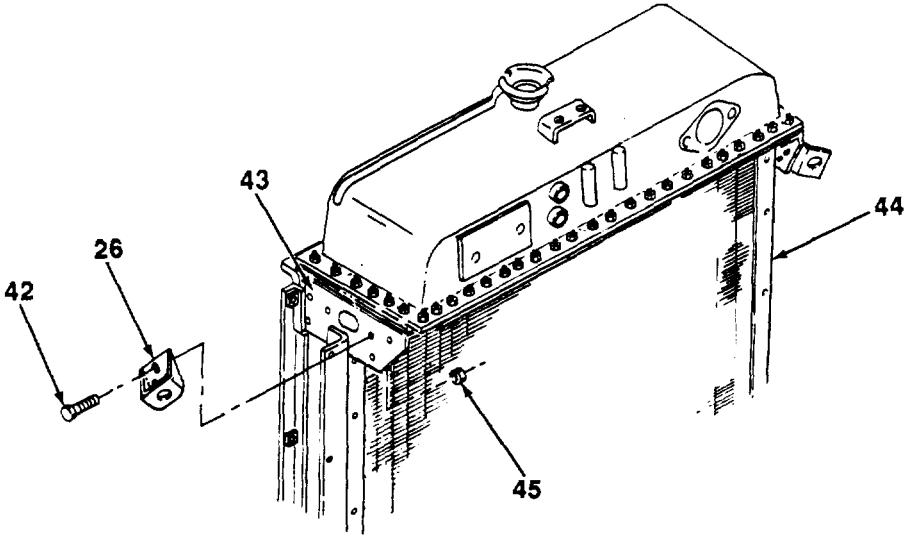

- 3. Install two mounting brackets (3) on radiator assembly (1) with two spacers (38), four bushings (39), new lockwashers (40), and screws (41).

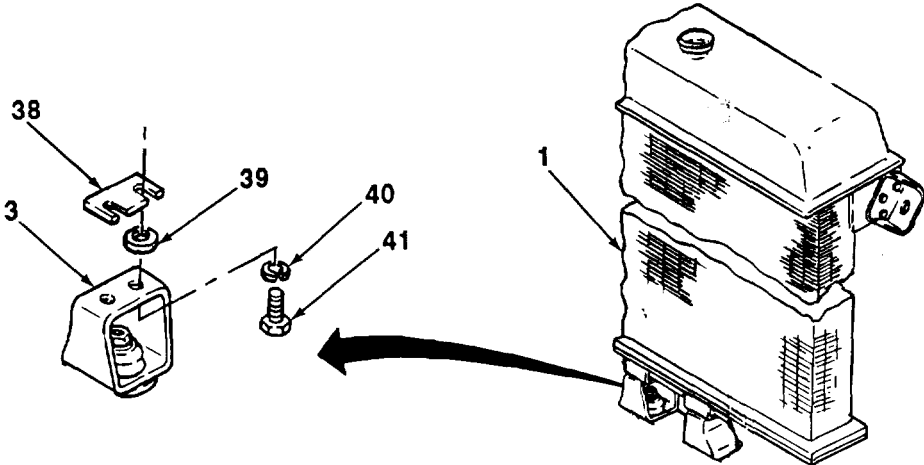

4-4. RADIATOR MAINTENANCE (Con't).

4. Tighten two nuts (57) at each end of two brace rods (59). Ensure that radiator assembly (1) and surrounding parts are square with each other. Tighten nuts against each other to lock radiator in place.
5. Install radiator shroud (see paragraph 4-5).
6. Attach lifting device to radiator assembly (1) and move radiator to vehicle.

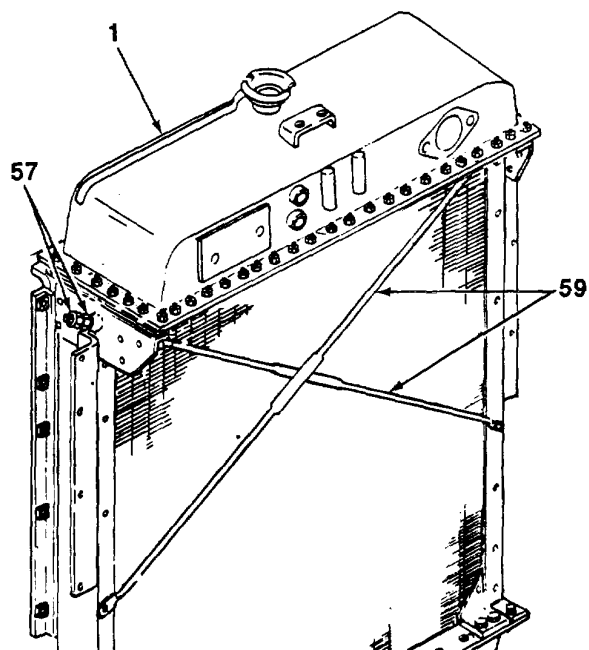

TA703684

4-4. RADIATOR MAINTENANCE (Con't).

NOTE

Ensure that spacer is still in place on top of each radiator mounting bracket.

- 7. Install radiator assembly (1) on channel (4) with two spacers (6), insulators (5), special washers (7), bolts (2), and nuts (8).

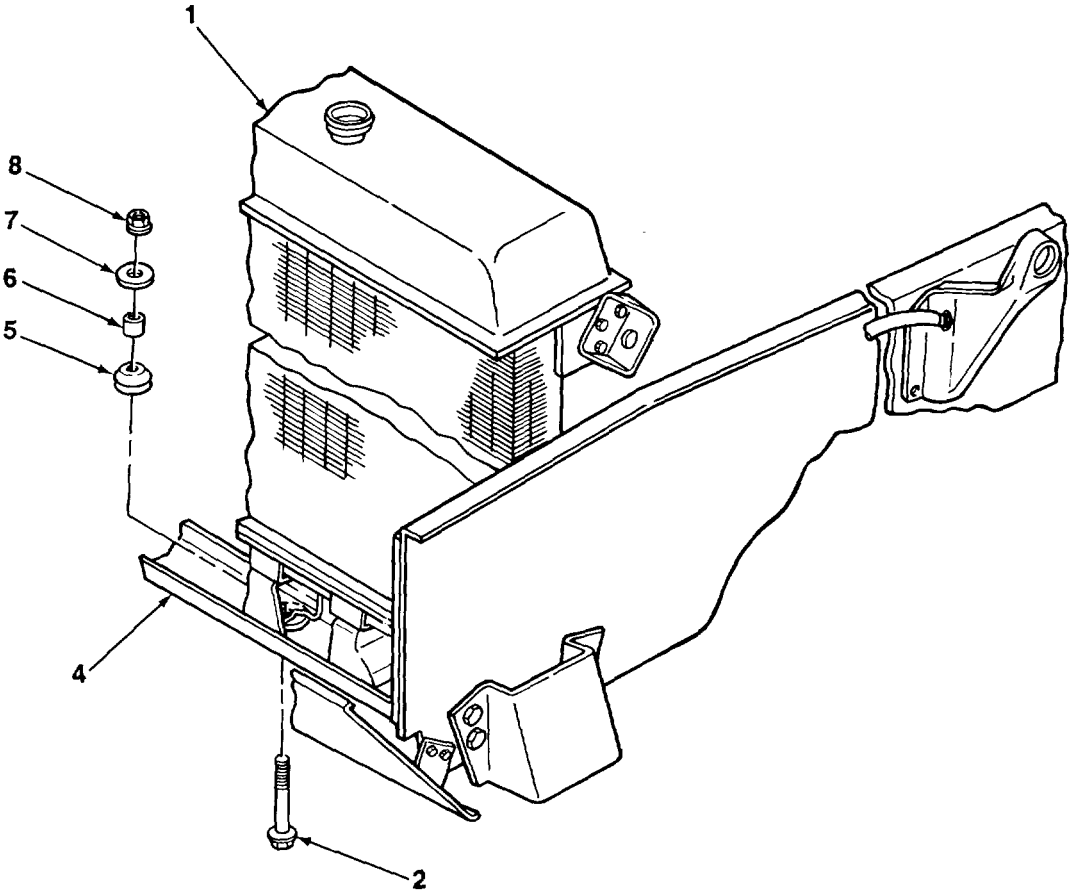

TA703685

4-4. RADIATOR MAINTENANCE (Con't).

NOTE

Perform steps 8 and 9 to Install left and right stabilizer rods.

8. If removed, install rear of stabilizer rod (27) to bracket (37) with bushing (36) two mounts (35), washers (34), new lockwashers (33), and nuts (32).
9. Install nut (31), new lockwasher (30), washer (29), and mount (28) on stabilizer rod (27).

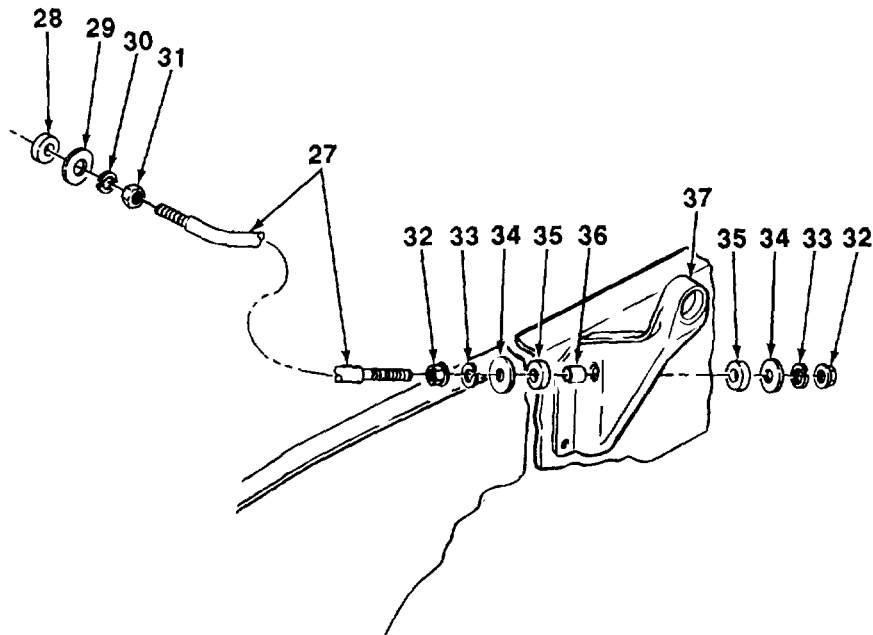

TA703686

4-4. RADIATOR MAINTENANCE (Con't).

NOTE

- * Perform step 10 at each side of radiator.
- * Ensure that radiator is square with vehicle frame as nuts are tightened.

10. Position stabilizer rod (27) in bracket (26) and install bushing (25), mount (24), washer (23), new lockwasher (22), and nut (21).
11. Remove lifting device.

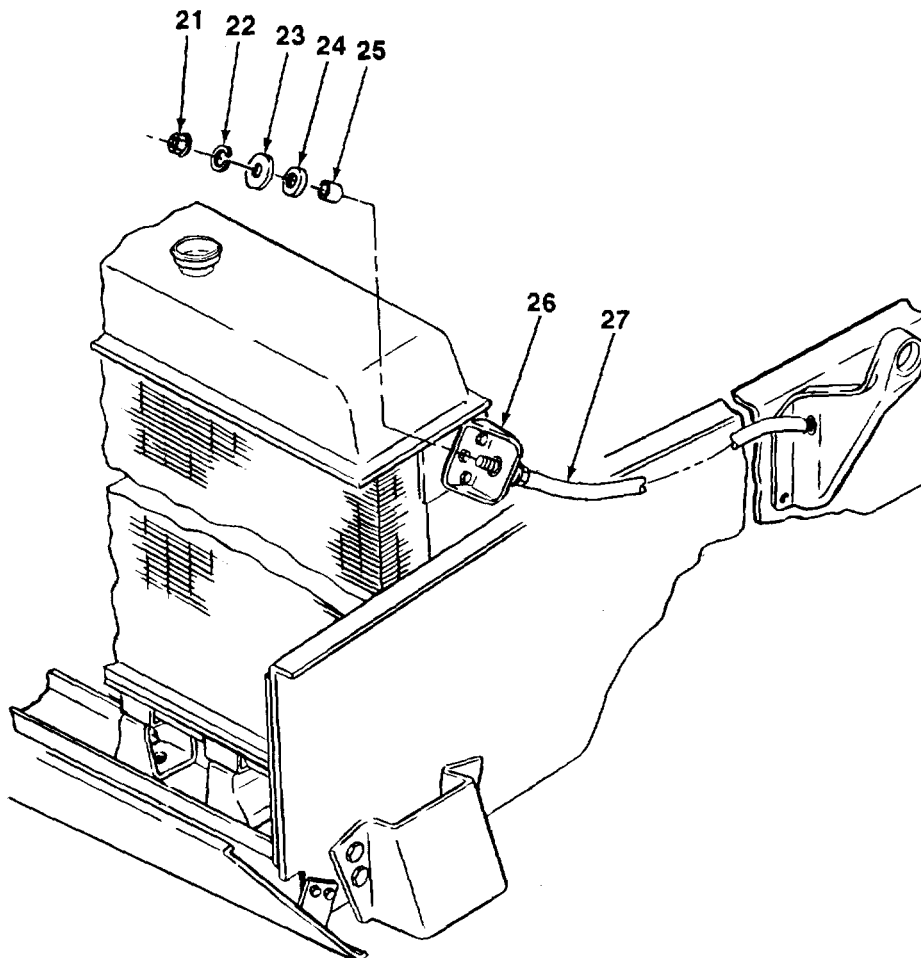
**NOTE**

Perform steps 12 through 15 if stabilizer rods were removed from vehicle.

12. Install right or left bracket (20) with two new lockwashers (19) and screws (18).
13. Install rod end (10) on right or left stabilizer rod (9).

TA703687

4-4. RADIATOR MAINTENANCE (Con't).

14. Install nut (14), washer (15), bushing (16), and spacer (17) on right or left stabilizer rod (9).
15. Install right or left stabilizer rod (9) in bracket (20) with bushing (16), washer (15), and nut (14).
16. Install right and left stabilizer rod (9) on radiator assembly (1) with two screws (11), new lockwashers (12), and

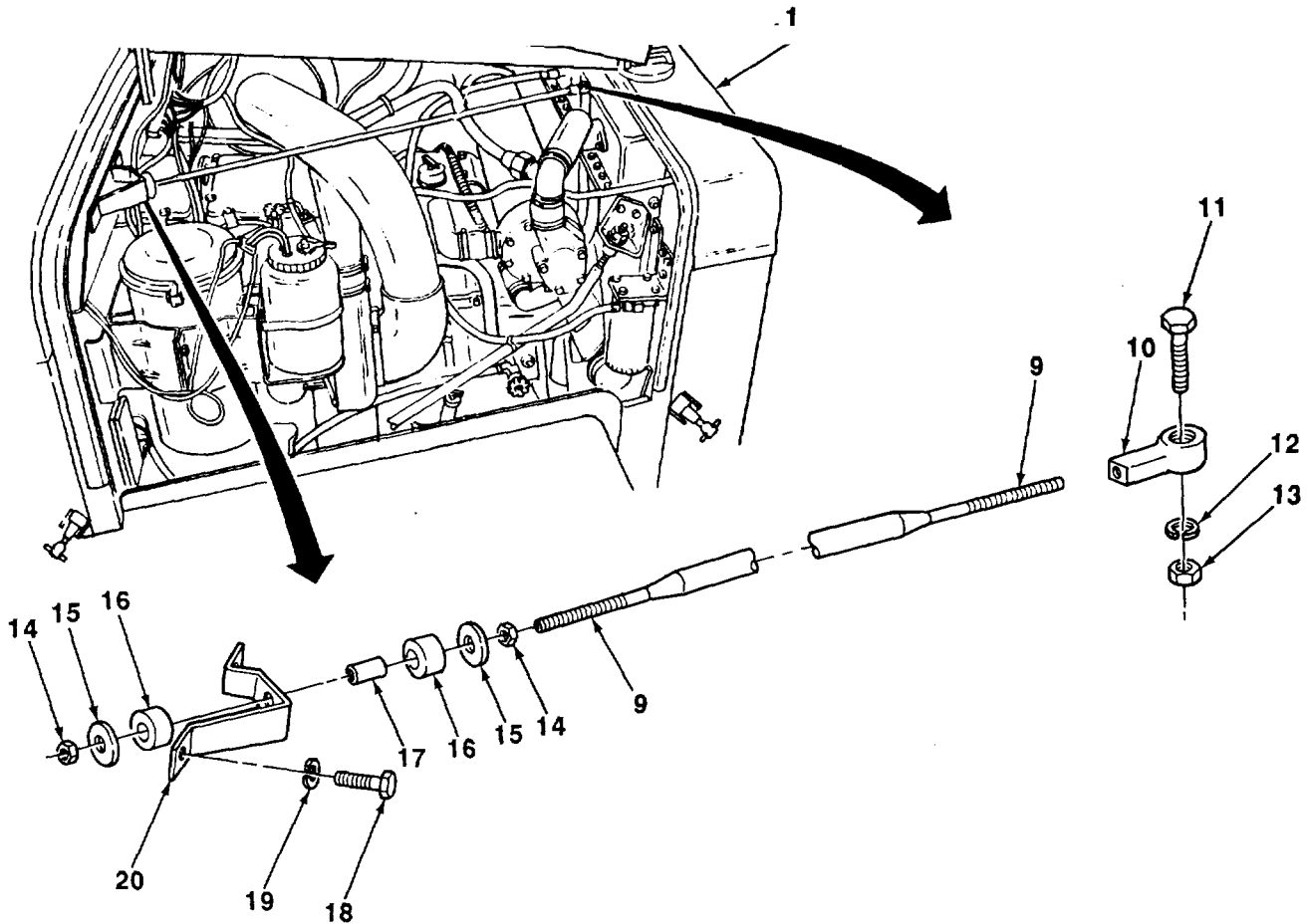

FOLLOW-ON TASKS:

- * Install radiator shell (see paragraph 4-3).
- * Install water filter hose (see TM 5-3805-254-20).
- * Install radiator vent hose and deaeration hose (see TM 5-3805-254-20).
- * Install radiator hose (see TM 5-3805-254-20).
- * Install radiator inlet hose (see TM 5-3805-254-20).
- * Install radiator outlet hose (see TM 5-3805-254-20).

TA703688

4-5. RADIATOR SHROUD REPLACEMENT.

This Task Covers: Replacement

Initial Setup:

Equipment Conditions:

- Radiator removed (see paragraph 4-4).

Tools/Test Equipment:

- General mechanic's tool kit

Materials/Parts:

- Ten lockwashers

REPLACEMENT

1. Remove ten screws (1), lockwashers (2), washers (3), and radiator shroud (4) from radiator (5). Discard lockwashers.
2. Install radiator shroud (4) to radiator (5) with ten washers (3), new lockwashers (2), and screws (1).

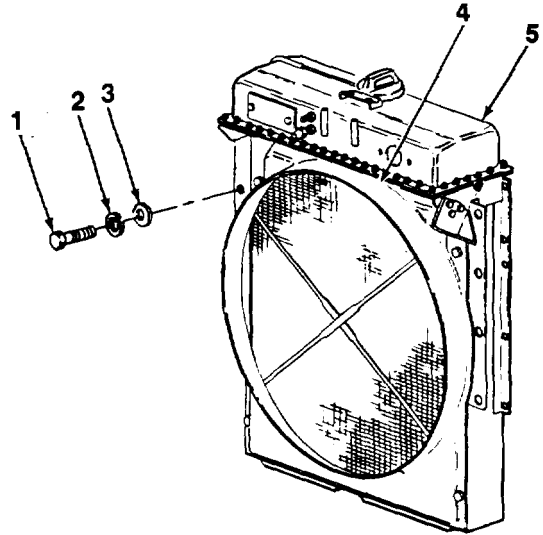
**FOLLOW-ON TASKS:**

- Install radiator (see paragraph 4-4).

TA703689

4-6. RADIATOR FAN REPLACEMENT.

This Task Covers: Replacement

Initial Setup:

Equipment Conditions:

- Radiator removed (see paragraph 4-4).

Materials/Parts:

- Six lockwashers

Tools/Test Equipment:

- General mechanic's tool kit
-

REPLACEMENT**NOTE**

Note direction fan blades curve to aid in installation.

1. Remove six screws (1), washers (2), radiator fan (3), and two spacers (4) from fan hub (5).
2. Install two spacers (4) and radiator fan (3) to fan hub (5) with six washers (2) and screws (1).

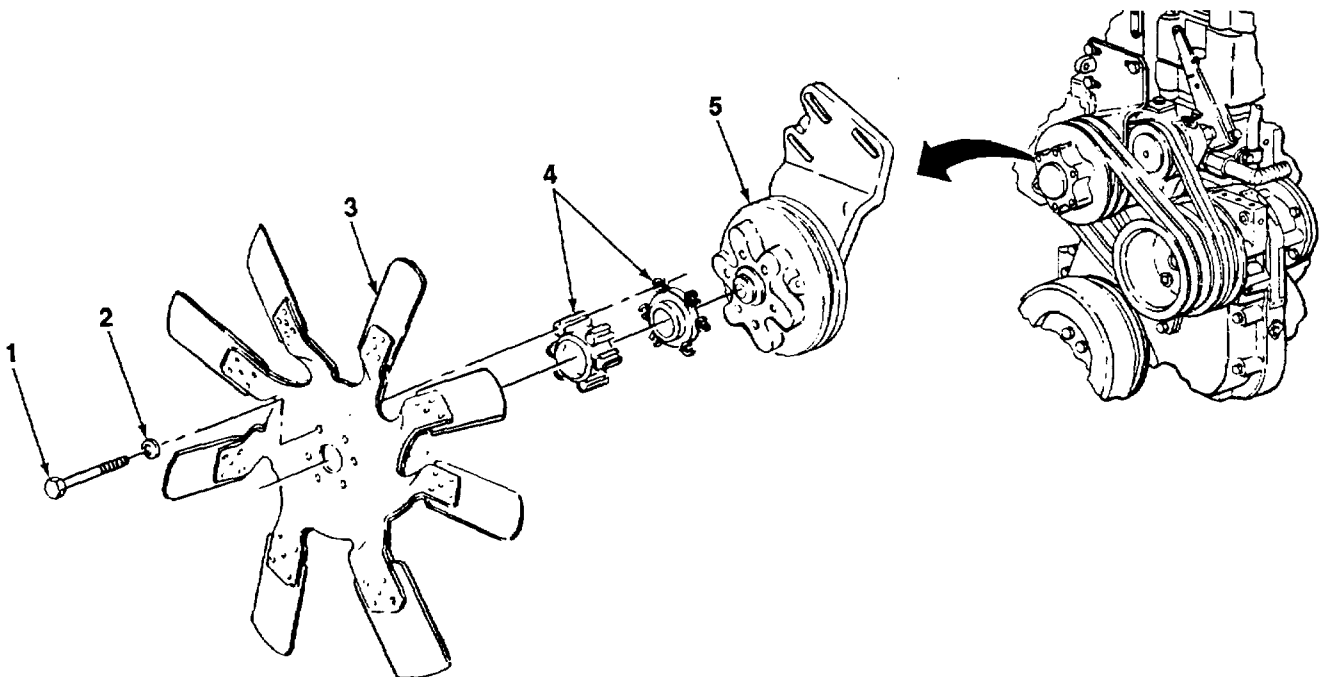
**FOLLOW-ON TASKS:**

- Install radiator (see paragraph 4-4).

TA703690

4-7. RADIATOR FAN HUB REPAIR

"

This Task Covers:

- a. Disassembly
- b. Cleaning and Inspection

- c. Assembly

*Initial Setup:***Equipment Conditions:**

- Fan hub removed (see TM 5-2815-241-34&P)

Tools/Test Equipment:

- General mechanic's tool kit
- Field automotive shop set

References:

- TM 9-214

General Safety Instructions:

- Dry cleaning solvent is flammable and must not be used near open flame. Use only in a well-ventilated area.

Materials/Parts:

- Grease (Item 10, Appendix B)
- Dry cleaning solvent (Item 23, Appendix B)
- One locknut
- One preformed packing
- One seal
- Three lockwashers

a. DISASSEMBLY

1. Remove adjusting screw (1), washer (2), and spacer (3) from fan support bracket (4).
2. Remove three screws (6), lockwashers (7), washers (8), and shaft bracket (5) from fan support to

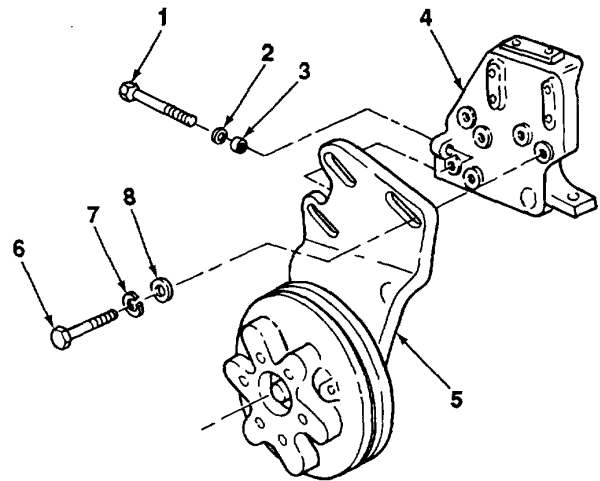

TA703691

4-7. RADIATOR FAN HUB REPAIR (Con't).

3. Remove retainer (9), preformed packing (10), and locknut (11) from shaft bracket (5). Discard preformed packing and locknut.
4. Remove pulley (12) and seal (13) from shaft bracket (5). Discard seal.

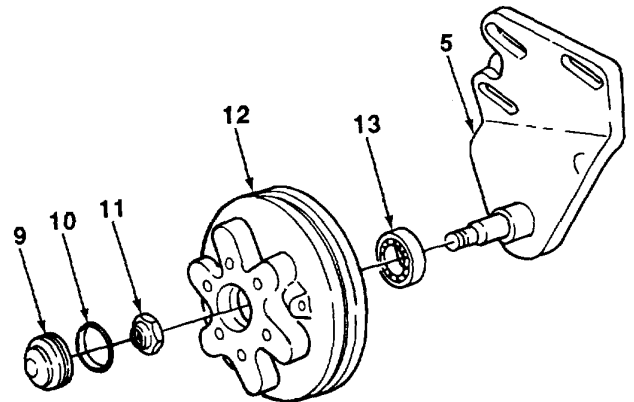

5. Remove two bearing assemblies (14) and retaining rings (15) from pulley (12).
6. Remove pipe plug (16) from pulley (12).

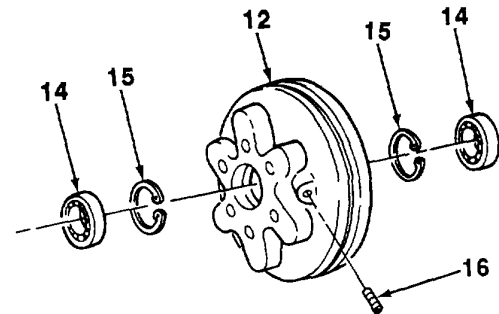
**b. CLEANING AND INSPECTION I****WARNING**

Dry cleaning solvent, PD680, is toxic and flammable. Always wear protective goggles and gloves, and use only in a well-ventilated area. Avoid contact with skin, eyes, and clothes, and DO NOT breathe vapors. DO NOT use near open flame or excessive heat. The solvent's flash point is 100°F/138°F (38°C/59°C). If you become dizzy while using cleaning solvent, immediately get fresh air and medical help. If solvent contacts eyes, immediately wash your eyes and get medical aid.

1. Clean bearing assemblies using dry cleaning solvent. Inspect bearing assemblies (see TM 9-214).

TA703692

4-7. RADIATOR FAN HUB REPAIR (Con't).**WARNING**

Dry cleaning solvent, PD680, is toxic and flammable. Always wear protective goggles and gloves, and use only in a well-ventilated area. Avoid contact with skin, eyes, and clothes, and DO NOT breathe vapors. DO NOT use near open flame or excessive heat. The solvent's flash point is 100°F/38°C. If you become dizzy while using cleaning solvent, immediately get fresh air and medical help. If solvent contacts eyes, immediately wash your eyes and get medical aid.

2. Clean shaft bracket, pulley, and internal components with dry cleaning solvent and allow to air dry.
3. Inspect shaft bracket for cracks and wear. Discard if cracked or worn.

c. ASSEMBLY

1. Apply grease to two bearing assemblies (14).
2. Install pipe plug (16) in pulley (12).
3. Install two retaining rings (15) and bearing assemblies (14) in pulley (12).

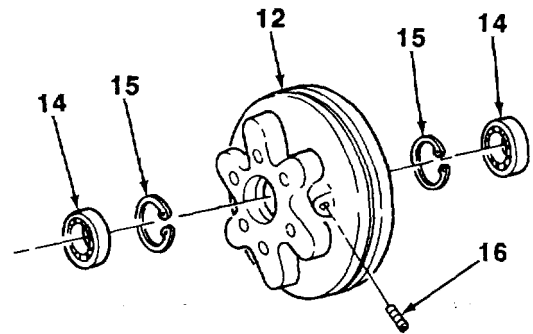

4. Install new seal (13) and pulley (12) to shaft bracket (5). Install new locknut (11), new preformed packing (10), and retainer (9) to shaft bracket (5).

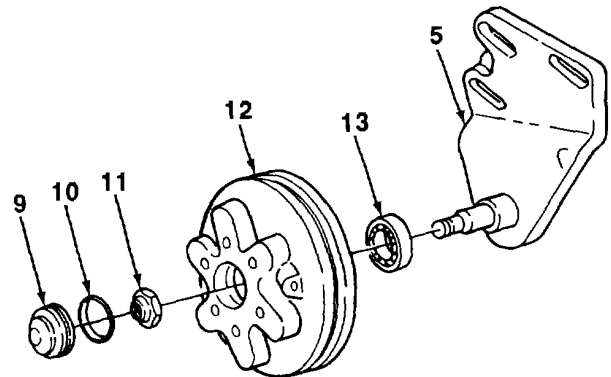

TA703693

4-7. RADIATOR FAN HUB REPAIR (Con't).

5. Install shaft bracket (5) to fan support bracket (4) with three washers (8), new lockwashers (7), and screws (6).
6. Loosely install adjusting screw (1), washer (2), and spacer (3) to fan support bracket (4).

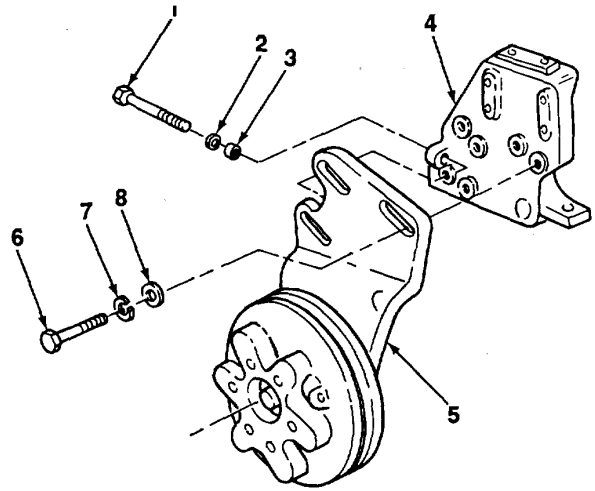
**FOLLOW-ON TASKS:**

- Install fan hub (see TM 5-2815-241-34&P).

TA703694

**CHAPTER 5
ELECTRICAL SYSTEM MAINTENANCE**

Paragraph Number	Paragraph Title	Page Number
5-1	Generator Repair.....	5-1
5-2	Starter Motor Test	5-11
5-3	Starter Motor Repair.....	5-14
5-4	Starter Motor End Play Adjustment.....	5-32
5-5	Starter Motor Solenoid Replacement	5-35
5-6	Engine, Transmission, Body and Chassis Wiring Harness Replacement.....	5-38
5-7	Wiring Diagram	5-39
5-8	Jacobs Exhaust Brake Wiring Harness Replacement	5-39

5-1. GENERATOR REPAIR.

This Task Covers:

- | | |
|--|--|
| <ul style="list-style-type: none"> a. Test and Disassembly b. Assembly | <ul style="list-style-type: none"> c. Bench Check |
|--|--|

Initial Setup:

Equipment Conditions:

- Generator pulley removed (see TM 5-3805-254-20).

Tools/Test Equipment:

- Automotive fuel and electrical system repair tool kit
- Automotive fuel and electrical system shop set
- Multimeter

Materials/Parts:

- Dry cleaning solvent (Item 23, Appendix B)
- Four lockwashers

General Safety Instructions:

- Dry cleaning solvent is flammable and must not be used near open flame. Use only in a well-ventilated area.

5-1. GENERATOR REPAIR (Con't).

a. TEST AND DISASSEMBLY

- 1. Remove fan (4) from shaft of rotor (2).
- 2. Remove four bolts (5) and end (1) from housing (3).

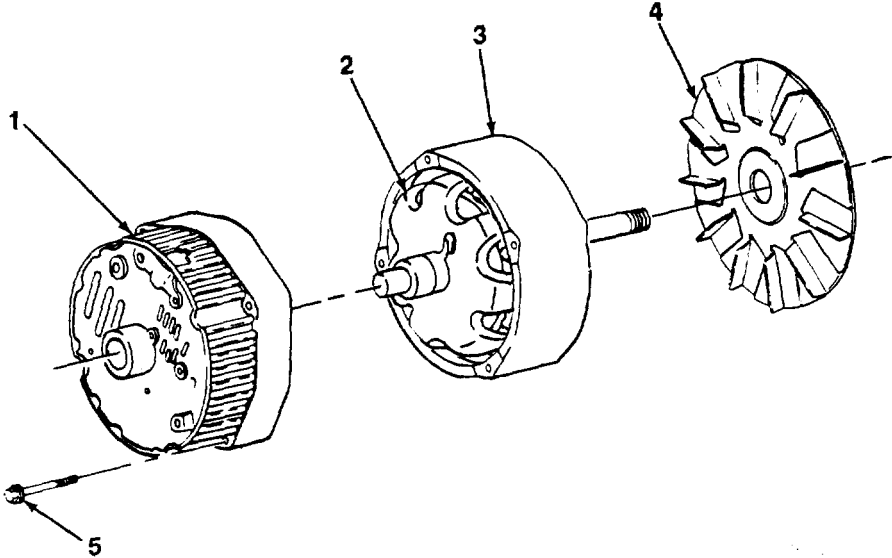

- 3. Remove collar (9) and rotor (2) from housing (3).
- 4. Connect multimeter to two slip rings (12). If reading is high (infinite), winding is open and rotor (2) must be replaced.

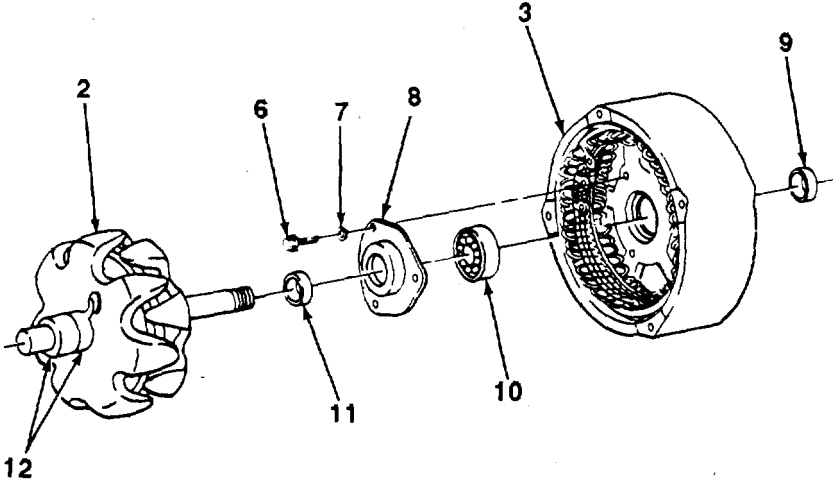

TA703695

5-1. GENERATOR REPAIR (Con't).

- 5. Remove bearing collar (11) from rotor (2).
- 6. Remove three screws (6), lockwashers (7), and plate (8) from housing (3). Discard lockwashers.
- 7. Remove bearing (10) from housing (3).
- 8. Connect one lead of multimeter to one stator lead (13) and the other lead to clean part of stator frame (15). If reading is high, windings are not properly grounded and stator (14) must be replaced.

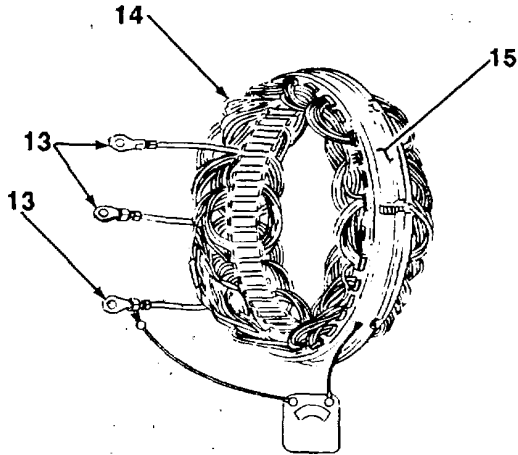

- 9. Remove three nuts (20) and stator (14) from end (1).
- 10. Using multimeter with 1 -volt cell set at lowest range scale, check diode (16) by connecting one lead to single connector (18) and other lead to one of three connectors (19). Record reading. Reverse multimeter leads to same two connectors. Record reading. If readings are the same, replace diode trio. A good diode trio will give one high and one low reading. Repeat step for other two connectors.
- 11. Remove screw (17) and diode (16) from end (1).

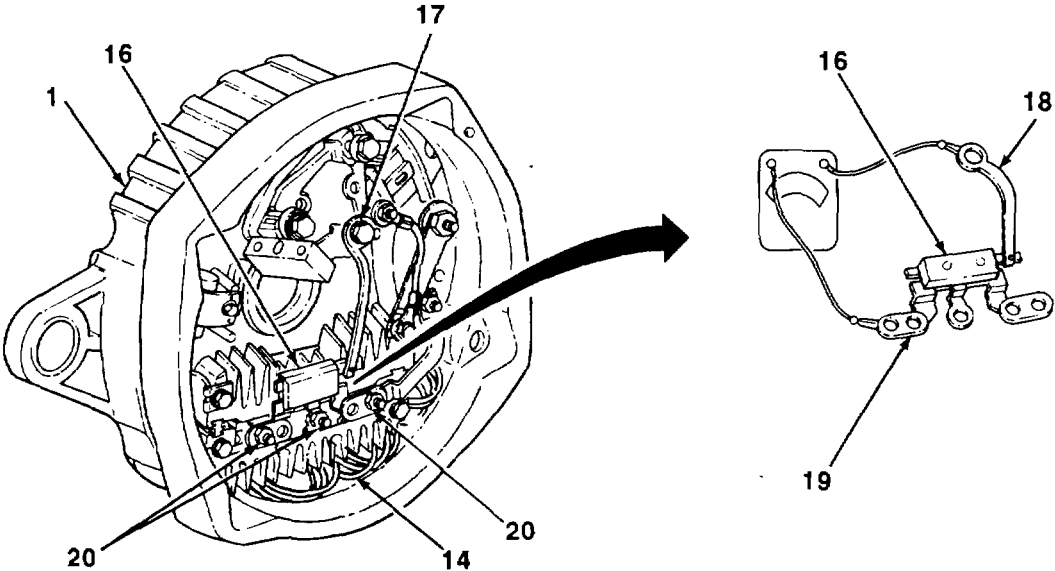

5-1. GENERATOR REPAIR (Con't).

12. Loosen two Insulated screws (21) and brush holder (22) from end (1).
13. Remove nut (23), screw (28), and wire (25).
14. Remove nut (24) and bracket (26) from end (1).
15. Remove nut (27) and bracket (29) from end (1).

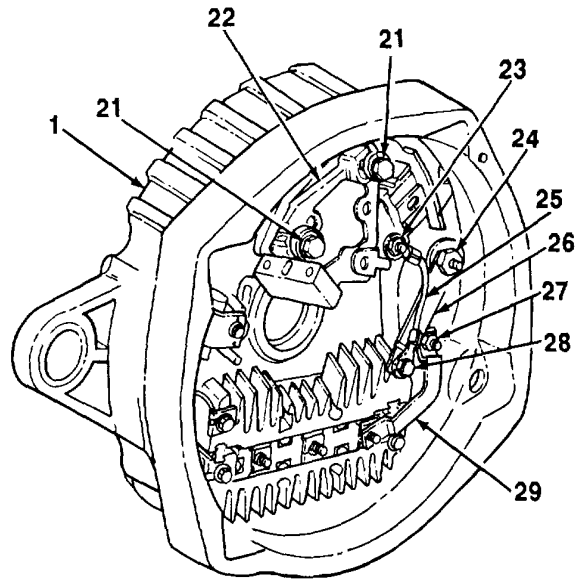

16. Connect multimeter to heat sink (31) and one flat metal chip (32). Press firmly on flat metal chip and record reading. Reverse lead connections and record reading. If both readings are the same, replace rectifier bridge (30). Repeat step for other heat sink and flat metal chips.

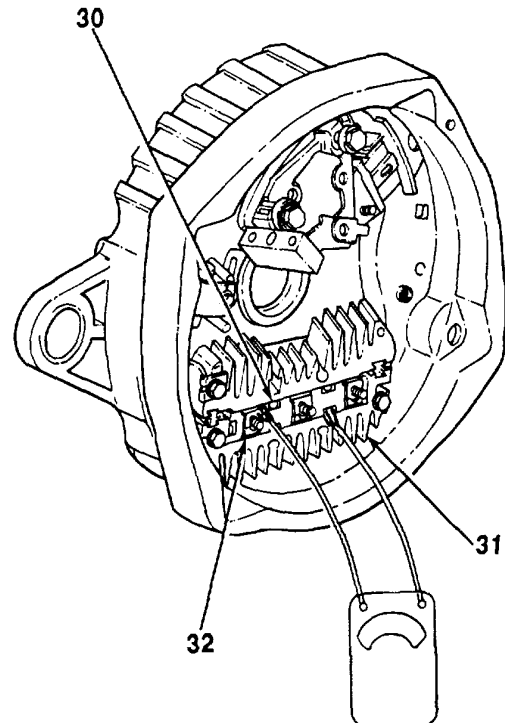

TA703697

5-1. GENERATOR REPAIR (Con't).

17. Remove three screws (34) and rectifier bridge (30) from end (1).

18. Remove screw (35) and capacitor (33) from end (1).

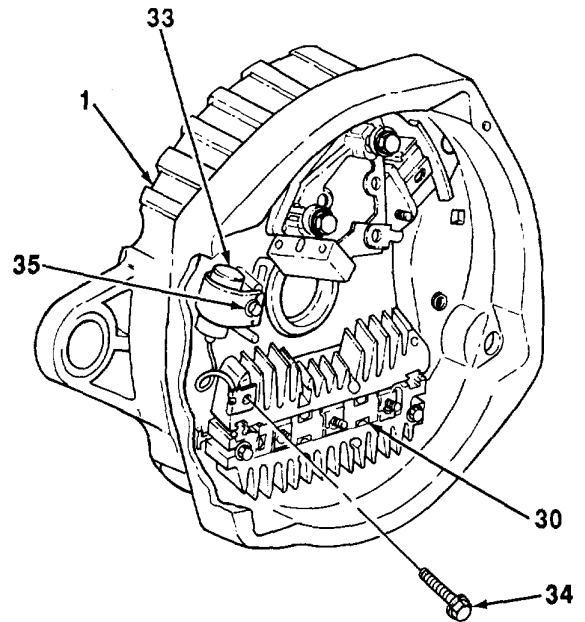

19. Set multimeter on lowest range scale and connect one lead to brush lead clip (36) and one lead to end (1). Record reading. Reverse lead connections and record reading. If both readings are zero, either brush lead clip is grounded or regulator (37) is defective.

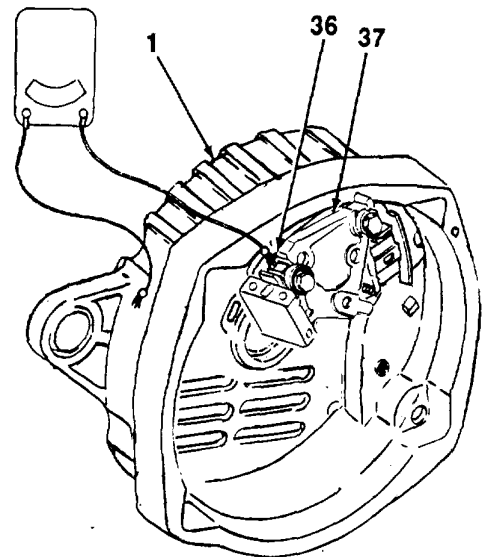

TA703698

5-1. GENERATOR REPAIR (Con't).

20. Remove two insulated screws (21) and plastic sleeves (41) and inspect sleeves. If sleeves are not missing or damaged, replace regulator.
21. Remove brush holder (22).
22. Remove screw (38), lockwasher (39), and retainer (40) from end (1). Discard lockwasher.
23. Remove regulator (37) from end (1).

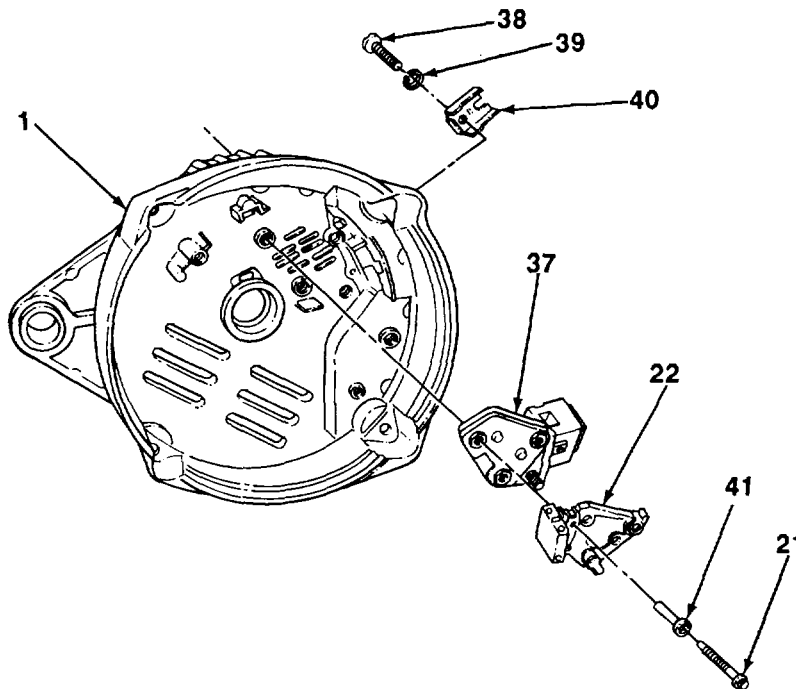
**b. ASSEMBLY**

1. Install regulator (37) to end (1).
2. Install retainer (40), new lockwasher (39), and screw (38).
3. Install brush holder (22).
4. Install two plastic sleeves (41) and insulated screws (21).

5-1. GENERATOR REPAIR (Con't).

5. Install capacitor (33) on end (1) with screw (35).
6. Install rectifier bridge (30) in end (1) with three screws (34).

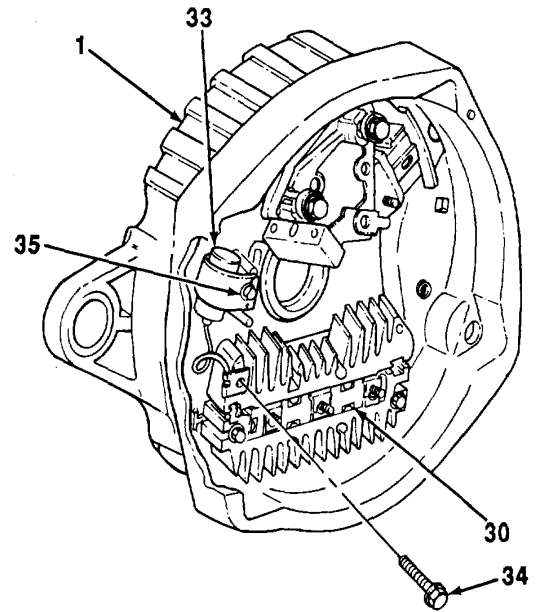

7. Install bracket (29) on end (1) with nut (27).
8. Install bracket (26) on end (1) with nut (24).
9. Install wire (25) with screw (28) and nut (23).

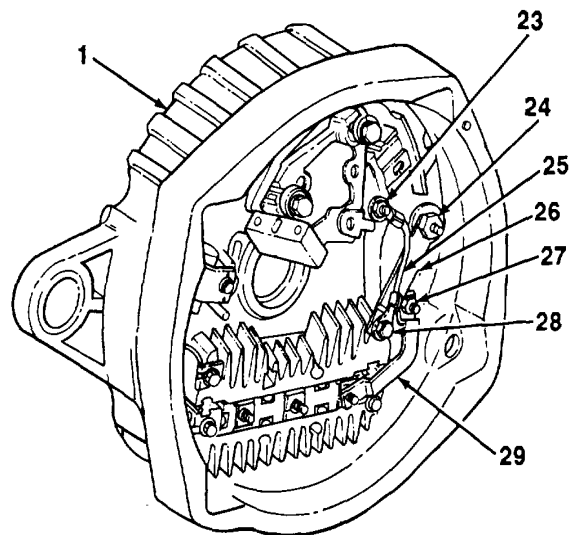

TA703700

5-1. GENERATOR REPAIR (Con't).

- 10. Install diode (16) with screw (17).
- 11. Position stator (14) in end (1) with three nuts (20).

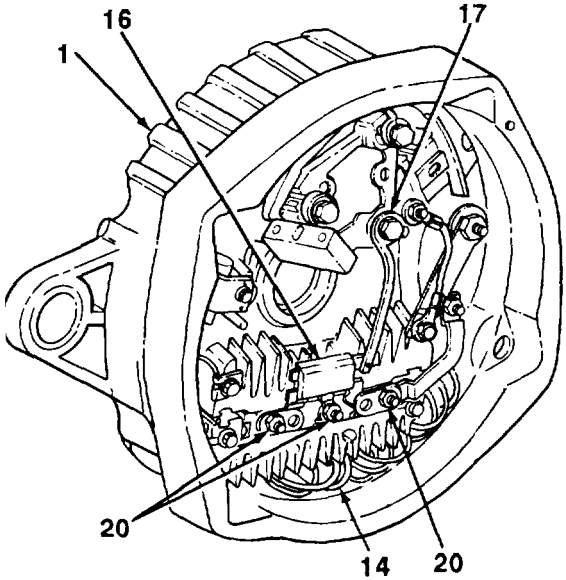

- 12. Install bearing (10) in housing (3).
- 13. Install plate (8) in housing (3) with three new lockwashers (7) and screws (6).
- 14. Install bearing collar (11) on rotor (2).
- 15. Install rotor (2) and collar (9) on housing (3).

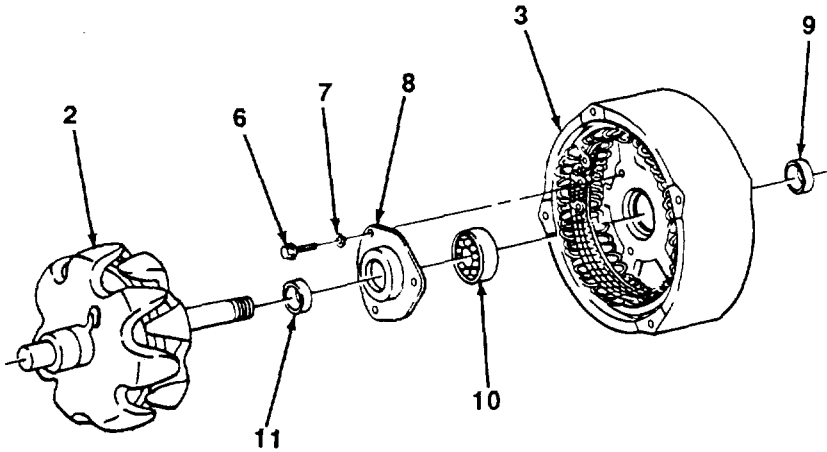

5-1. GENERATOR REPAIR (Con't).

16. Install end (1) on housing (3) with four bolts (5).
17. Install fan (4) on shaft of rotor (2).

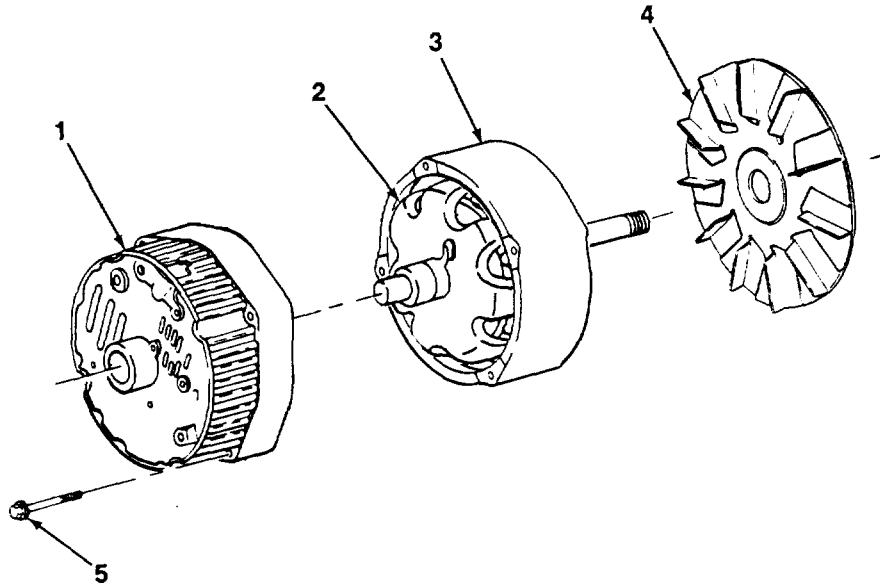

c. BENCH CHECK

1. Position generator in holding fixture.

NOTE

Ground polarity of energizer or battery and generator must be the same. Use a fully charged battery and a 10-ohm resistor rated at six watts or more between generator no. 1 terminal and battery.

2. Make connections as illustrated, except leave carbon pile disconnected.
3. Slowly increase generator speed and observe voltage.
 - (a) If voltage is uncontrolled with speed and increases above 15.5 volts on a 12-volt system, check for a grounded brush lead clip (see subparagraph a). If not grounded, replace regulator and check field winding (see subparagraph b).
 - (b) If voltage is below 15.5 volts on a 12-volt system, connect carbon pile as shown.

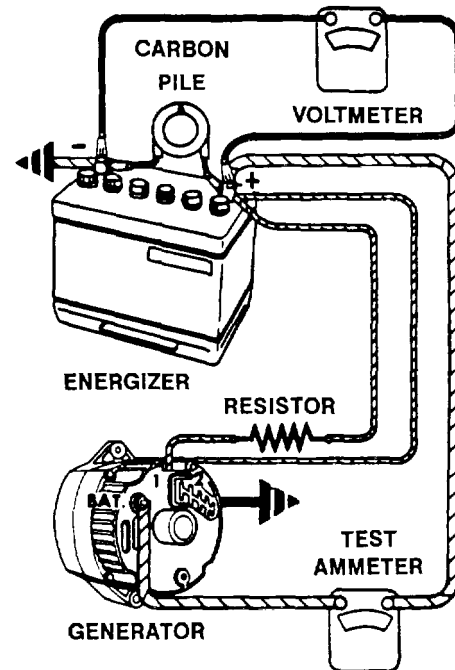

TA703702

5-1. GENERATOR REPAIR (Con't).

4. Operate generator at moderate speed as required and adjust carbon pile as required to obtain maximum current output.
 - (a) If output is within 10% of rated output as stamped on generator frame, generator is good.
 - (b) If output is not within 10% of rated output, keep battery loaded with carbon pile and ground generator field by inserting screwdriver to ground tab (42) to end frame.

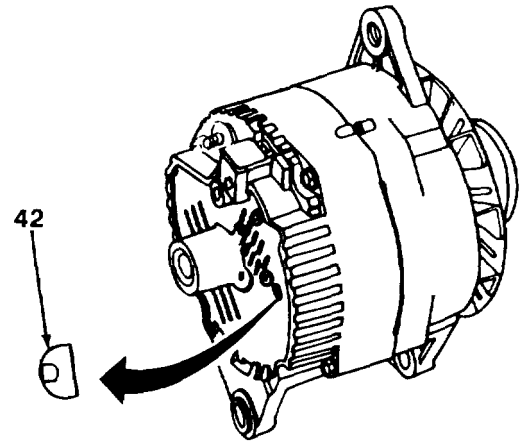

5. Operate generator at moderate speed and adjust carbon pile as required to obtain maximum output.
 - (a) If output is within 10% of rated output, replace regulator and check field winding (see subparagraph b).
 - (b) If output is not within 10% of rated output, check field winding, diode trio, rectifier bridge, and stator (see subparagraph a).

FOLLOW-ON TASKS:

- Install generator pulley (see TM 5-3805-254-20).

5-2. STARTER MOTOR TEST.

This Task Covers: Testing

Initial Setup:

Equipment Conditions:

- Starter motor removed (see TM 5-3805-254-20).

Materials/Parts:

- Rags (Item 17, Appendix B)
- Dry cleaning solvent (Item 23, Appendix B)
- Two gaskets

Tools/Test Equipment:

- Automotive fuel and electrical system repair tool kit
- Automotive fuel and electrical system shop set

General Safety Instructions:

- Dry cleaning solvent is flammable and must not be used near open flame. Use only in a well-ventilated area.
-

TESTING**WARNING**

Dry cleaning solvent, P-D-680, is toxic and flammable. Always wear protective goggles and gloves, and use only in a well-ventilated area. Avoid contact with skin, eyes, and clothes, and DO NOT breathe vapors. DO NOT use near open flame or excessive heat. The solvent's flash point is 100°F-138°F (380C-590C). If you become dizzy while using cleaning solvent, immediately get fresh air and medical help. If solvent contacts eyes, immediately wash your eyes and get medical aid.

1. Clean outside of starter motor (4) with dry cleaning solvent and a rag.
2. Turn starter housing collar (1) clockwise and counterclockwise. If starter housing collar and armature shaft (7) do not turn freely, repair starter motor (see paragraph 5-3).

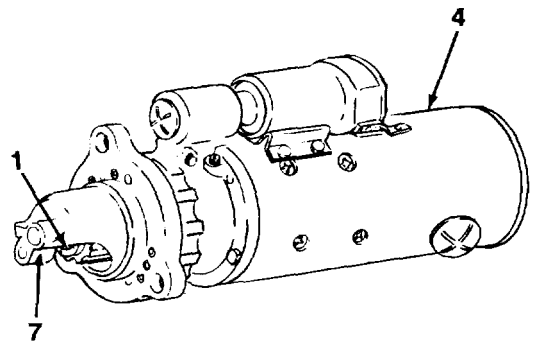

TA703704

5-2. STARTER MOTOR TEST (Con't).

3. Remove two plugs (16) and gaskets (15) from housing (8). Inspect plugs for damage. Replace if damaged. Discard gaskets.
4. Set multimeter to RX1 scale and check continuity between two brush terminals (11). If multimeter reads 10 ohms or more, repair starter motor (see paragraph 5-3).
5. Set multimeter to RX10,000 scale. Check continuity between each brush terminal (11) and housing (8). If multimeter reads anything except infinity, repair starter motor (see paragraph 5-3).

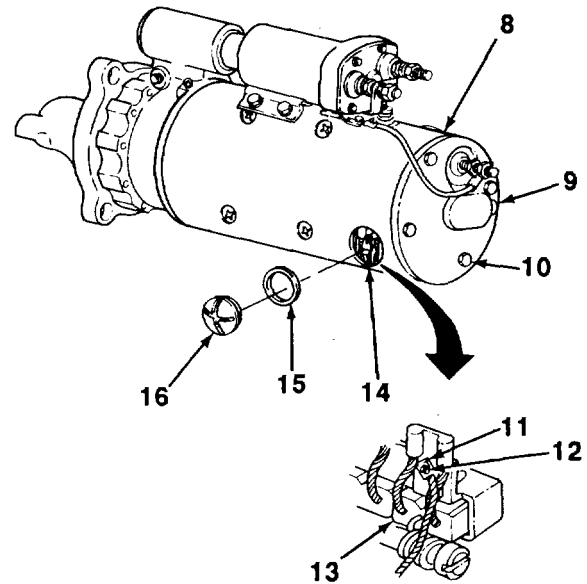

6. Set multimeter to RX1 scale. Check continuity between terminal (19) and B terminal (18). If multimeter reads more than 10 ohms, replace starter motor solenoid (see paragraph 5-5).
7. Set multimeter to RX10,000 scale. Check resistance between terminal (19) and switch case (17). Check resistance between M terminal (20) and switch case. Check resistance between B terminal (18) and switch case. If multimeter reads anything except infinity for any checks, replace starter motor solenoid (see paragraph 5-5).
8. Install starter motor on alternator and starter automotive generator test stand. Operate test stand in accordance with operating instructions.

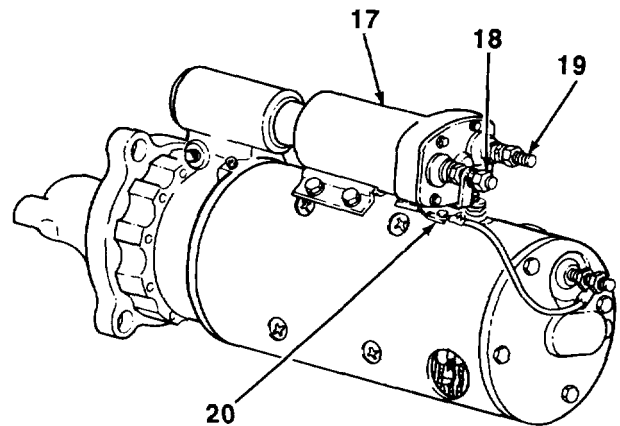

TA703705

5-2. STARTER MOTOR TEST (Con't).

9. Check motor current, speed, and voltage. Motor current should be 70-110 amps dc, speed should be 550-9000 rpms, and voltage should be 20 Vdc.

NOTE

Perform step 10 only if check in step 9 gave accepted values or If starter motor does not vibrate or make noise.

10. Install two new gaskets (15) and plugs (16) in housing (8).

NOTE

Perform steps 11 through 16 only if check in step 9 did not give accepted values or motor vibrates or makes noise.

11. Inspect four screws (10) in commutator end bell (9) for tightness Tighten any loose screws.
12. Inspect two screws (12) holding brushes (13) for tightness. Tighten any loose screws through opening (14).
13. Install two new gaskets (15) and plugs (16) in housing (8).
14. Inspect six screws (2) in drive housing (3) and eight shoe pole screws (5) for tightness. Tighten any loose screws.
15. Inspect lever housing (6) for tightness. If lever housing is loose, repair starter motor (see paragraph 5-3).
16. Repeat step 9. If starter motor still does not give accepted values or if starter motor vibrates or makes noise, repair starter motor (see paragraph 5-3).

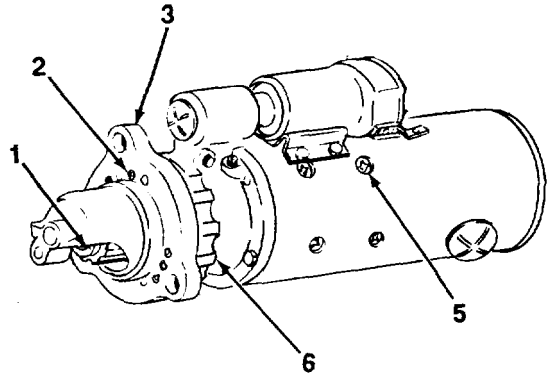
**FOLLOW-ON TASKS:**

- Install starter (see TM 5-3805-254-20).
- Lubricate starter (see LO 5-3805-254-12).

5-3. STARTER MOTOR REPAIR.

This Task Covers:

- a. Test and Disassembly
- b. Assembly
- c. Bench Check

Initial Setup:

Equipment Conditions:

- Starter motor solenoid removed (see paragraph 5-5).

Tools/Test Equipment:

- Automotive fuel and electrical system repair tool kit
- Automotive fuel and electrical system shop set

General Safety Instructions:

- Dry cleaning solvent is flammable and must not be used near open flame. Use only in a well-ventilated area.
- Compressed air used for cleaning purposes should never exceed 30 psi (207 kPa).

Materials/Parts:

- Adhesive (Item 1, Appendix B)
- Abrasive cloth (Item 4, Appendix B)
- Lubricating oil (Item 13, Appendix B)
- Dry cleaning solvent (Item 23, Appendix B)
- One locknut
- One oil seal
- Two preformed packings
- Two retaining rings
- Three felt wicks
- Seven gaskets
- Thirteen lockwashers

a. DISASSEMBLY

1. Scribe three match-marks (7) on end cap (1), field frame (2), lever housing (3), and drive housing (6).
2. Remove two inspection plugs (9) and gaskets (8) from field frame (2). Discard gaskets.
3. Remove inspection plug (5) and gasket (4) from lever housing (3). Discard gasket.

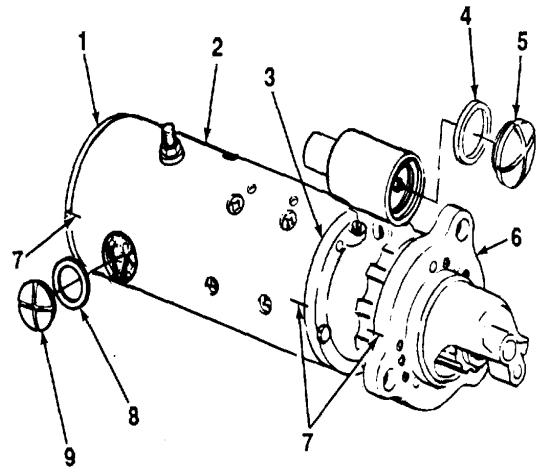

TA703707

5-3. STARTER MOTOR REPAIR (Con't).

- 4. Remove three screws (10) and lockwashers (11) from field leads (12) and brushes (13). Discard lockwashers.

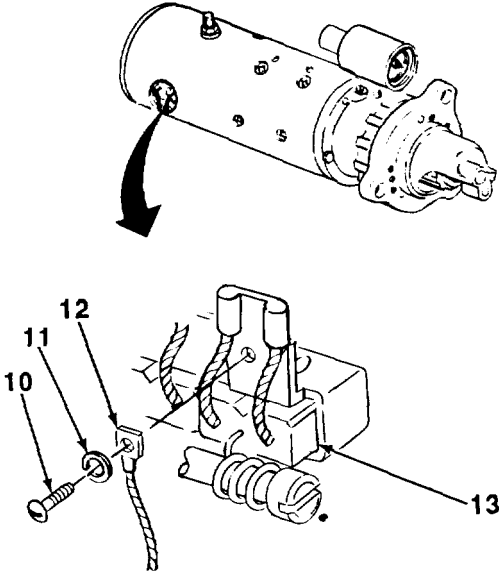

- 5. Remove four screws (17), lockwashers (16), end cap (1), gasket (14), and brushes (13) from armature (15). Discard lockwashers and gasket.
- 6. Remove armature (15) from field frame (2).

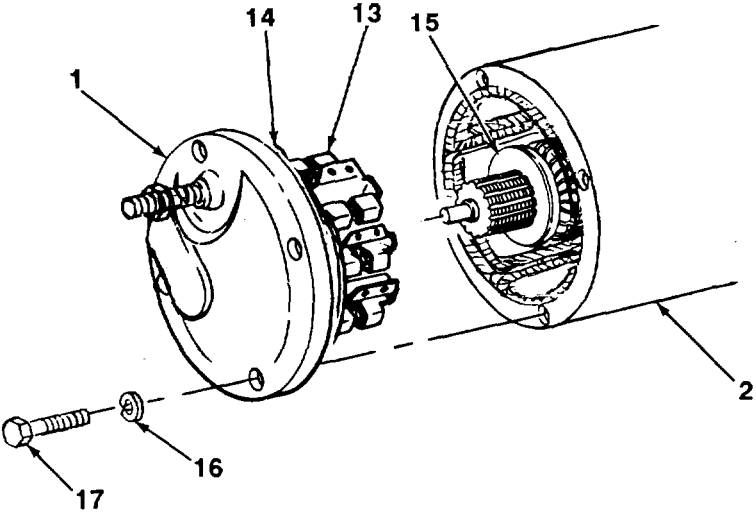

5-3. STARTER MOTOR REPAIR (Con't).

7. Remove washer (18) and thrustwasher (19) from armature (15).

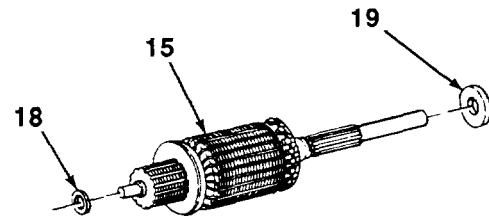

8. Remove five screws (21), lockwashers (20), drive housing (6), and lever housing (3) from field frame (2). Discard lockwashers.

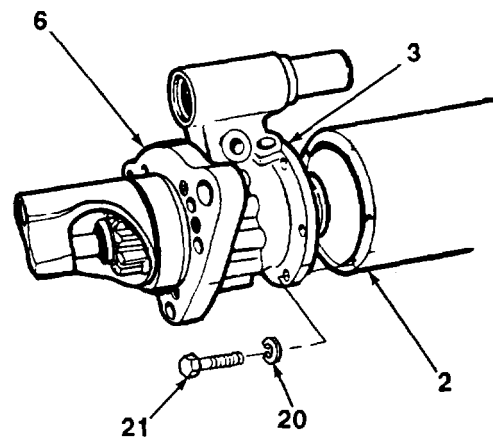

9. Remove five long screws (22), short screw (29), and drive housing (6) from lever housing (3).
10. Remove starter drive (28) and gasket (27) from lever housing (3). Discard gasket.
11. Remove retaining ring (26) and shift lever shaft (24) from lever housing (3). Discard retaining ring.
12. Remove large preformed packing (23) and small preformed packing (25) from shift lever shaft (24). Discard preformed packings.

TA703709

5-3. STARTER MOTOR REPAIR (Con't).

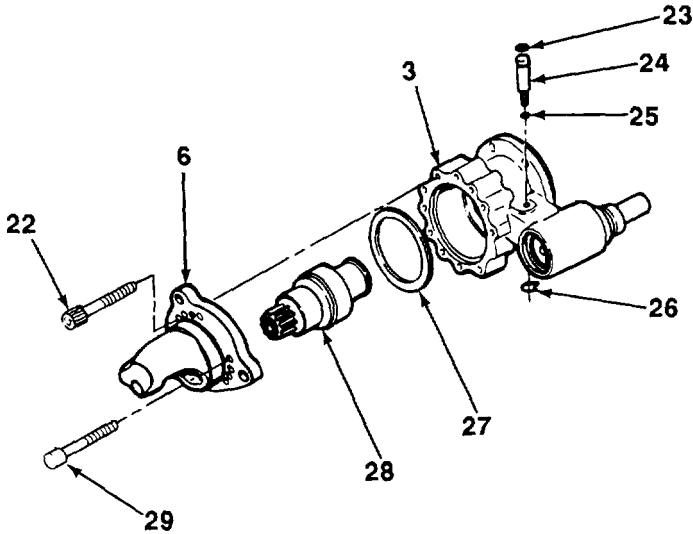

NOTE

Note number of turns required to remove locknut from plunger.

- 13. Remove locknut (34), plunger (33), and shift lever (30) from lever housing (3). Discard locknut.
- 14. Remove and discard gasket (31) and oil seal (32) from lever housing (3).
- 15. Remove retaining ring (35), retainer (36), spring (37), retainer (38), boot (39), and washer (40) from plunger (33). Discard retaining ring.

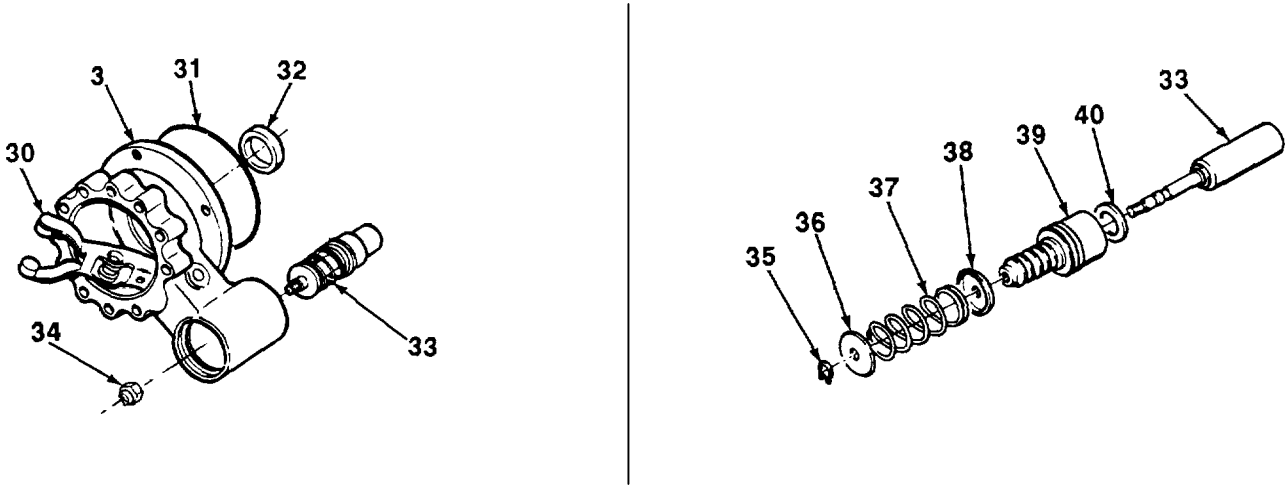

5-3. STARTER MOTOR REPAIR (Con't).

16. Remove washer (43) and bushing (44) from lever housing (3).

17. Remove cap plug (45) and felt wick (46) from lever housing (3). Discard felt wick.

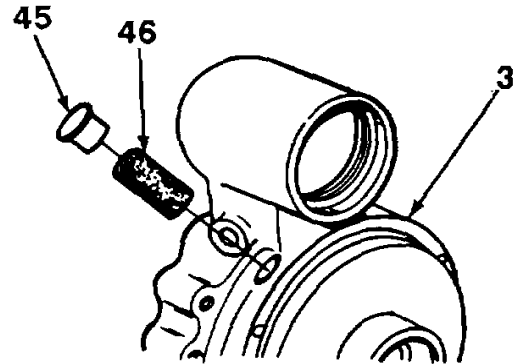
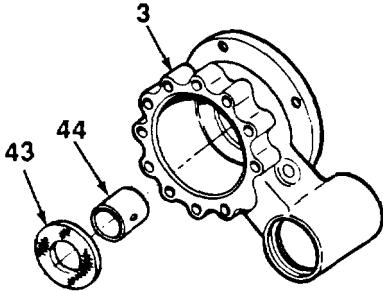

18. Remove cap plug (48) and felt wick (49) from drive housing (6). Discard felt wick.

19. Mark holes and remove six rubber balls (47) from drive housing (6).

20. Remove bushing (50) from drive housing (6).

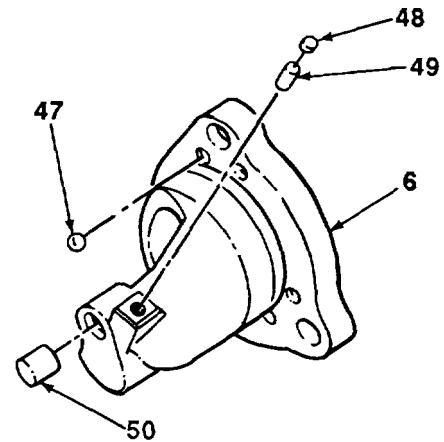

5-3. STARTER MOTOR REPAIR (Con't).

- 21. Remove six screws (51) and brush leads (52) from bracket (56).
- 22. Remove eight brushes (13) from brush holders (55).
- 23. Remove four screws (54) and springs (53) from end cap (1).

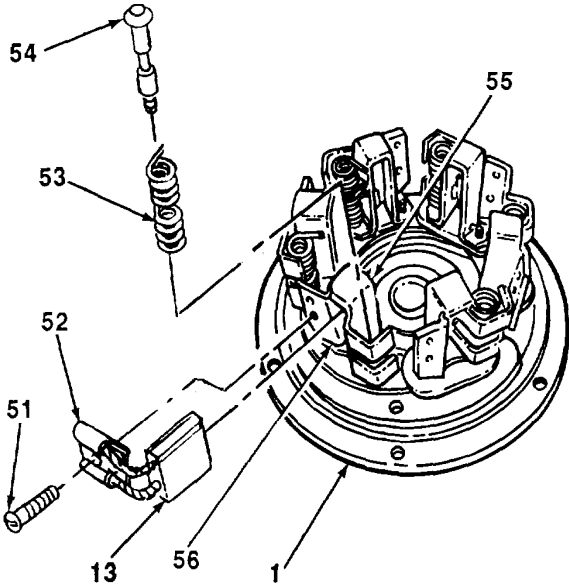

- 24. Remove nut (57), lockwasher (58), washer (59), and insulator (60) from ground terminal (61). Discard lockwasher.
- 25. Remove three screws (63) from holder assembly (62).

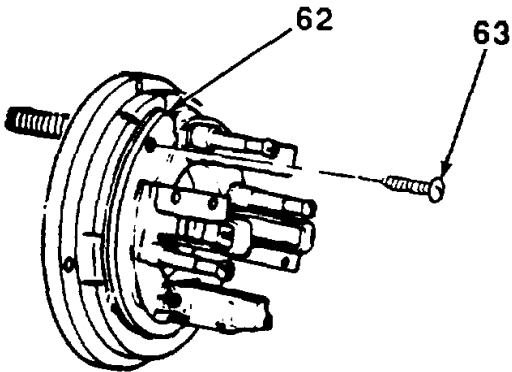
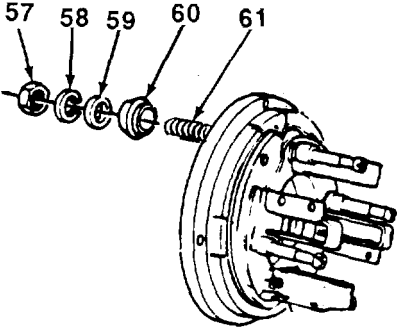

TA703712

5-3. STARTER MOTOR REPAIR (Con't).

26. Separate end cap (1) from holder assembly (62) and remove rubber bushing (65) and two insulating washers (66) from ground terminal (61).
27. Remove gasket (64) from holder assembly (62). Discard gasket.

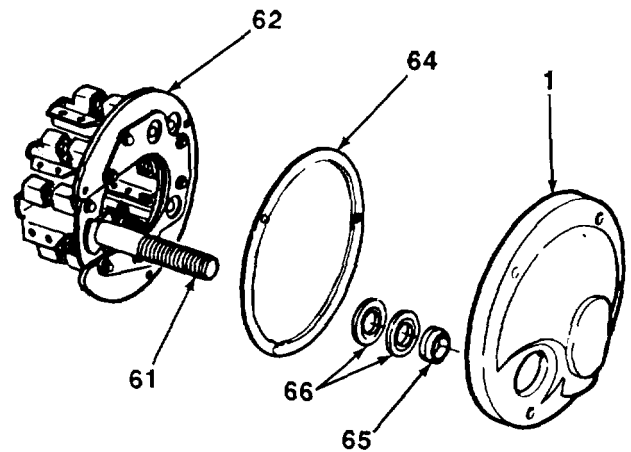

28. Remove cap plug (68) and felt wick (67) from end cap (1). Discard felt wick.
29. Remove bushing (69) from end cap (1).

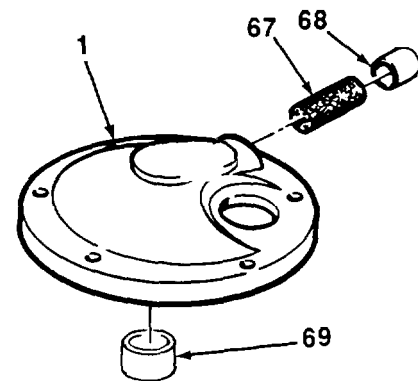

30. Remove four screws (75), brush holders (55), plates (74), plate insulators (73), and eight insulators (72) from holder assembly (62).
31. Remove support plate (70) and disc insulator (71) from holder assembly (62).

5-3. STARTER MOTOR REPAIR (Con't).

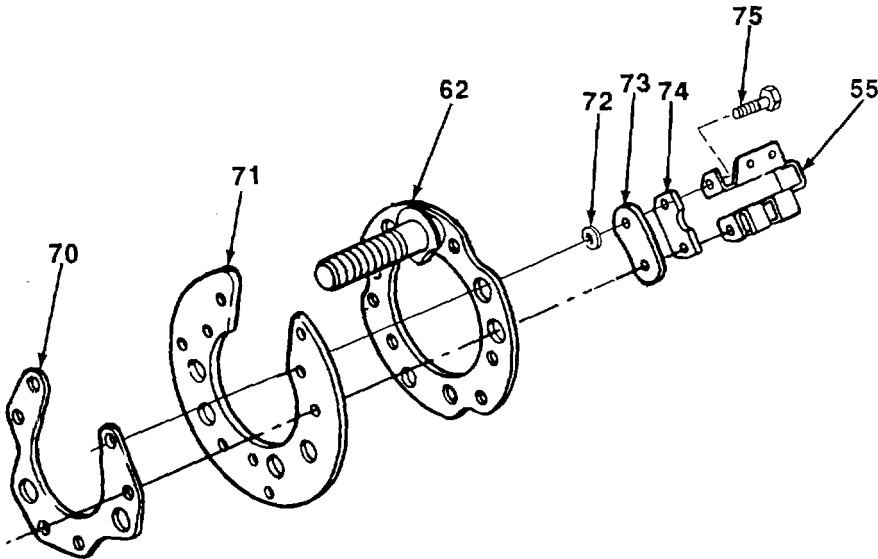

32. Remove nut (79), washer (78), and two insulators (77) from terminal stud (76).

33. Remove eight screws (81) and four pole shoes (80) from field frame (2).

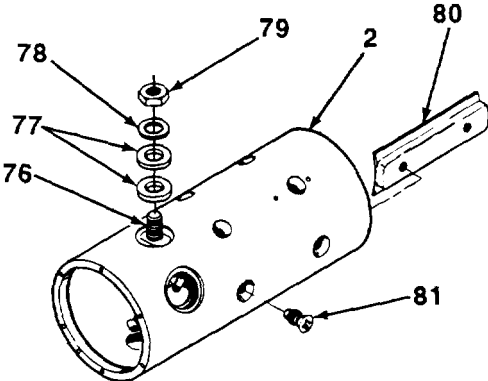

TA703714

5-3. STARTER MOTOR REPAIR (Con't).

34. Remove field coil (84) and plate insulator (82) from field frame (2).
35. Remove insulator bushing (83) from terminal stud (76).

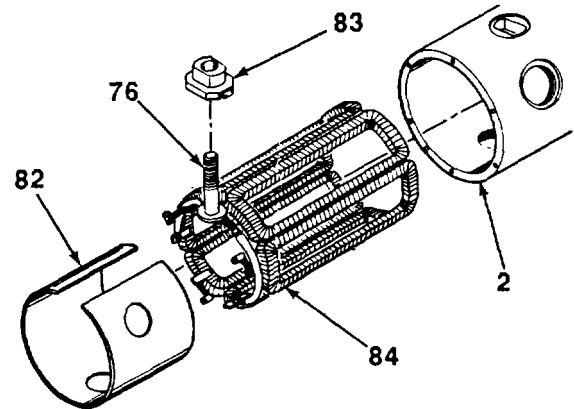

b. CLEANING AND INSPECTION

WARNING

Dry cleaning solvent, P-D-680, is toxic and flammable. Always wear protective goggles and gloves, and use only in a well-ventilated area. Avoid contact with skin, eyes, and clothes, and DO NOT breathe vapors. DO NOT use near open flame or excessive heat. The solvent's flash point is 100°F-138°F (38°C-59°C). If you become dizzy while using cleaning solvent, immediately get fresh air and medical help. If solvent contacts eyes, immediately wash your eyes and get medical aid.

1. Clean all metal parts except armature, field coil, and starter drive with dry cleaning solvent.
2. Clean starter drive with dry, clean cloth.
3. Inspect field frame for cracks, breaks, and other damage. Replace field frame if damaged, cracked, or broken.
4. Inspect commutator (85) contact surface for rough surface, pits, scoring, burns, hard carbon, oil coat, and out-of-round. Commutator diameter, when new, is 2.3125-2.3250 in. (58.7375-59.0550 mm). Commutator diameter may not be less than 2.00 in. (50.80 mm) when returned to service. Commutator may not be more than 0.0020 in. (0.0508 mm) out-of-round.

TA703715

5-3. STARTER MOTOR REPAIR (Con't).**WARNING**

Compressed air used for cleaning or drying purposes, or for clearing restrictions, should never exceed 30 psi (207 kPa). Wear protective clothing (goggles/shield, gloves, etc.) and use caution to avoid injury to personnel.

5. Cut commutator (85) as required on lathe. When cutting commutator, cut no more than 0.005 in. (0.127 mm) at a time to remove scoring, pits, burrs, or to return commutator to round. Then make final cut of 0.002 in. (0.051 mm). Undercut mica (86) A2 in. (0.79 mm) deep and A2 in. (0.79 mm) wide. Remove all loose copper and mica particles with compressed air.

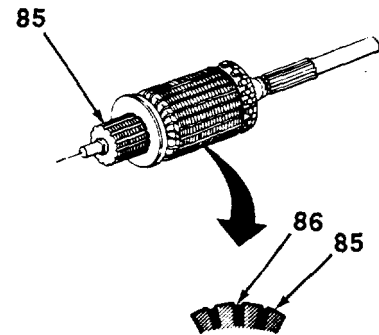

7. Check length of brushes. If length is less than 0.50 in. (12.70 mm), replace brushes.
8. Inspect brush springs for distortion. Replace brush springs if distorted.
9. Inspect splines and gear teeth on starter drive for damage. Replace starter drive if splines or gear teeth are damaged.
10. Inspect bushings for damage and wear. If inside diameter of bushings is more than 0.005 in. (0.127 mm) larger than shaft diameter, replace bushings.
11. Inspect all other parts for damage. Replace damaged parts.

c. ASSEMBLY

1. Install insulator bushing (83) on terminal stud (76).
2. Install plate insulator (82) and field coil (84) on field frame (2).

TA703716

5-3. STARTER MOTOR REPAIR (Con't).

- 3. Install four pole shoes (80) on field frame (2) with eight screws (81).
- 4. Install two insulators (77), washer (78), and nut (79) on terminal stud (76).

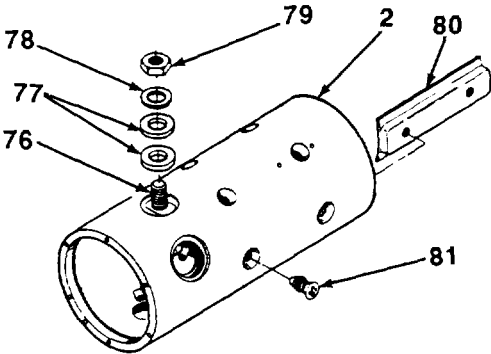

- 5. Position disc insulator (71) and support plate (70) on holder assembly (62).
- 6. Install eight insulators (72), four plate insulators (73), plates (74), and brush holders (55) on holder assembly (62) with four screws (75).

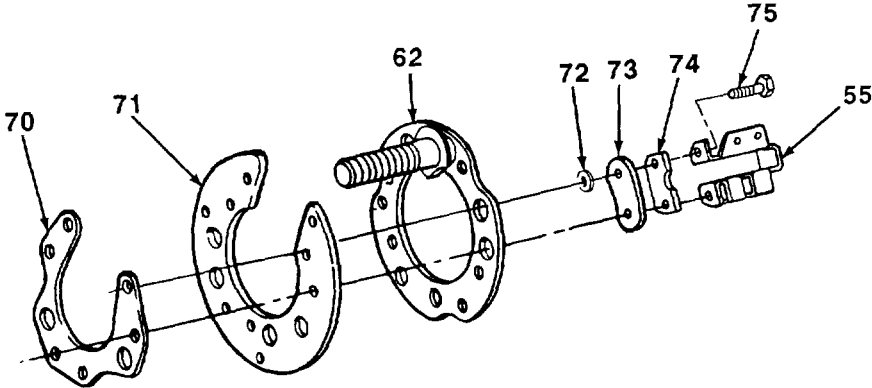

TA703717

5-3. STARTER MOTOR REPAIR (Con't).

7. Press bushing (69) into end cap (1) until flush with top of bore.

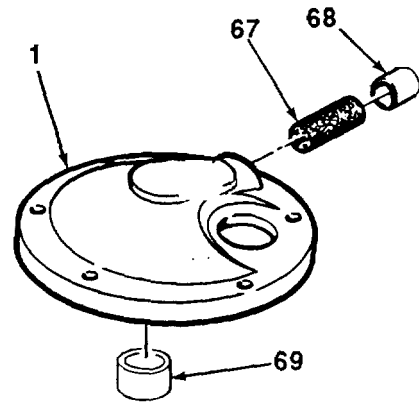

8. Install new gasket (64) on end cap (1).
9. Install new felt wick (67) on end cap (1) and fill with oil.
10. Install cap plug (68) on end cap (1).
11. Install two insulating washers (66) and rubber bushing (65) on ground terminal (61).

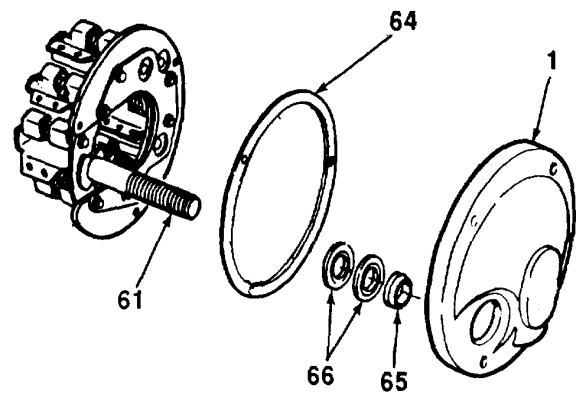

TA703718

5-3. STARTER MOTOR REPAIR (Con't).

- 12. Install three screws (63) on holder assembly (62).
- 13. Install insulator (60), washer (59), new lockwasher (58), and nut (57) on ground terminal (61).

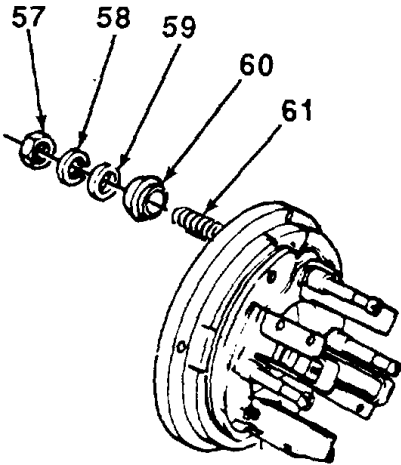
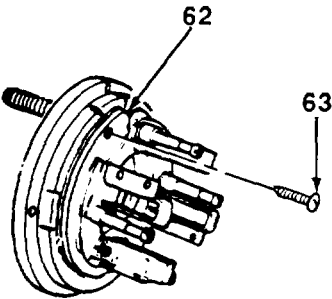

- 14. Install four springs (53) on end cap (1) with four screws (54).
- 15. Position eight brushes (13) in brush holders (55).
- 16. Install four brush leads (52) on brackets (56) with six screws (51).

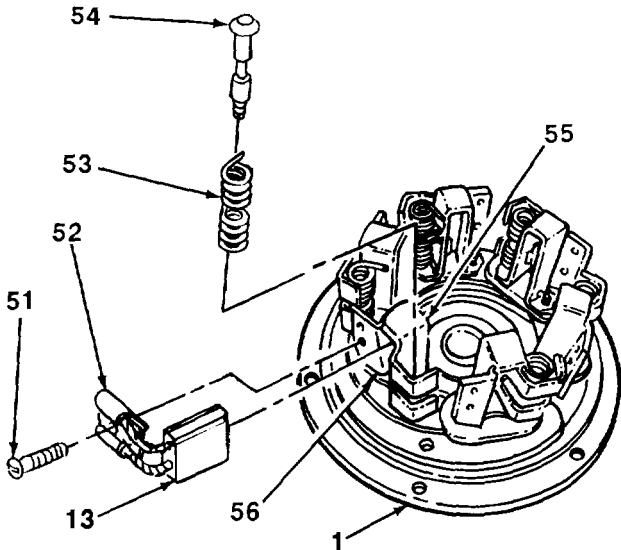

TA703719

5-3. STARTER MOTOR REPAIR (Con't).

17. Install bushing (50) In drive housing (6).
18. Install six rubber balls (47) in drive housing (6).

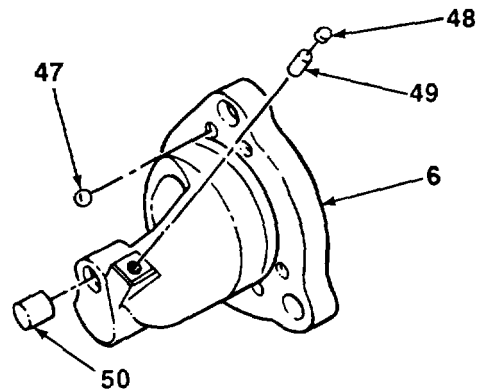

19. Install new felt wick (46) in lever housing (3) and fill with oil.
20. Install cap plug (45) on lever housing (3).

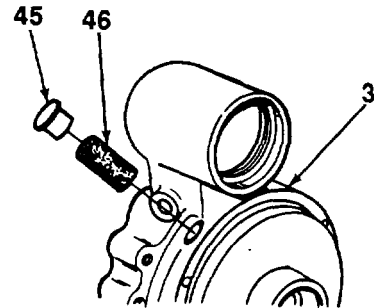

21. Install new felt wick (49) in drive housing (6) and fill with oil.
22. Install cap plug (48) on drive housing (6).
23. Install bushing (44) on lever housing (3).
24. Apply adhesive to back of washer (43) and install on lever housing (3).

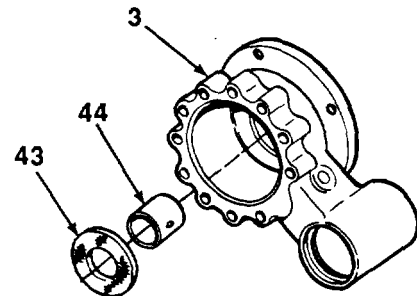

TA703720

5-3. STARTER MOTOR REPAIR (Con't).

25. Install washer (40) in boot (39).
26. Install boot (39) on plunger (33). Push boot down so collar (42) on boot fits into groove (41).
27. Install retainer (38), spring (37), and retainer (36) on boot (39) with retaining ring (35).

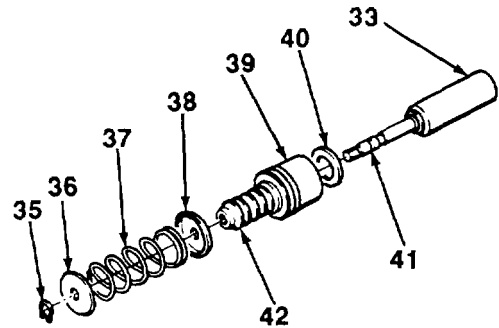

28. Install new oil seal (32) and new gasket (31) on lever housing (3).
29. Position shift lever (30) in lever housing (3) and install plunger (33) assembly with new locknut (34).

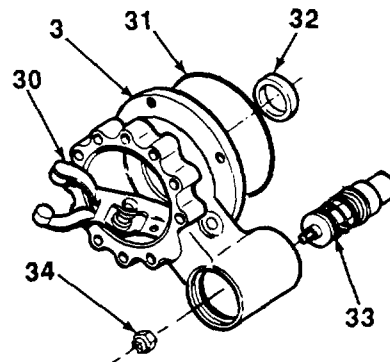

30. Install shift lever shaft (24) in lever housing (3).
31. Install new small preformed packing (25) and new large preformed packing (23) on shift lever shaft (24).
32. Install new retaining ring (26) on shift lever shaft (24).
33. Position new gasket (27) and starter drive (28) on lever housing (3).
34. Aline match-marks on drive housing (6) and lever housing (3). Install drive housing on lever housing with short screw (29) and five long screws (22).

TA703721

5-3. STARTER MOTOR REPAIR (Con't).

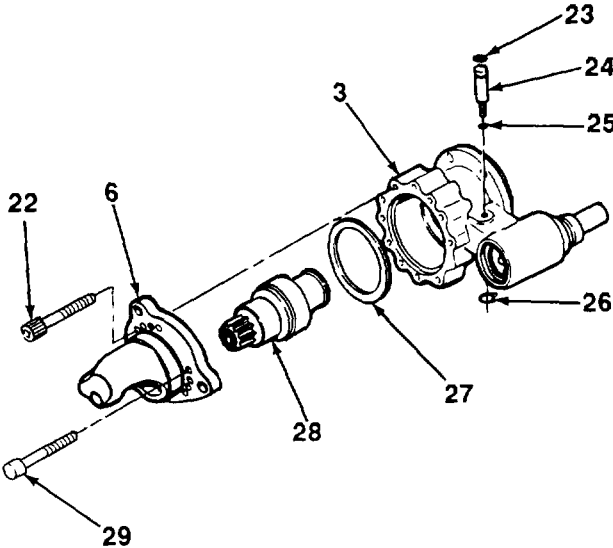

35. Aline match-marks on lever housing (3) and field frame (2). install lever housing and drive housing (6) on field frame with five new lockwashers (20) and screws (21).

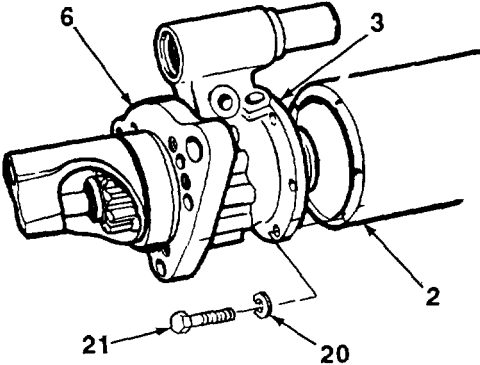

36. Install thrustwasher (19) and washer (18) on armature (15).

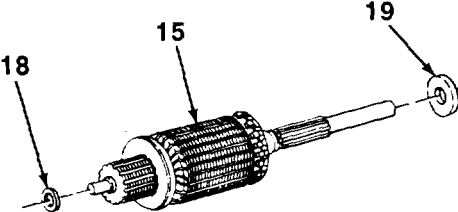

5-3. STARTER MOTOR REPAIR (Con't).

- 37. Position armature (15) in field frame (2).
- 38. Aline match-marks on end cap (1) and field frame (2). Install brushes (13), new gasket (14), and end cap on armature (15) and field frame with four new lockwashers (16) and screws (17).

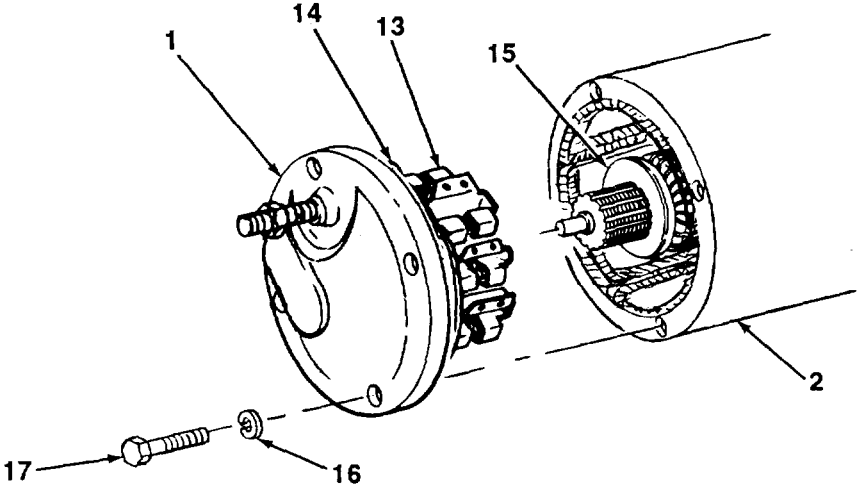

- 39. Install three field leads (12) on brushes (13) with three new lockwashers (11) and screws (10).

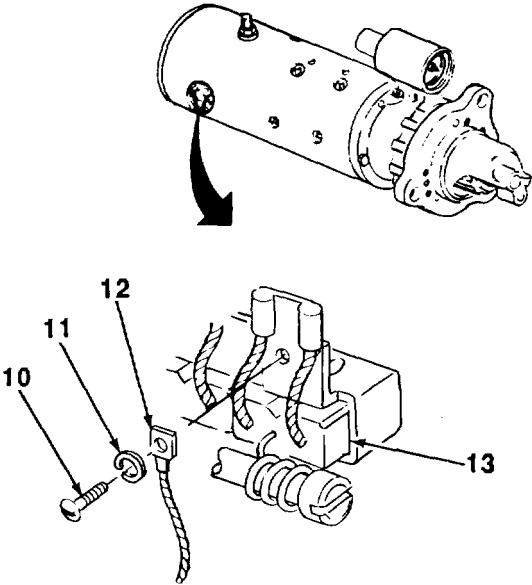

5-3. STARTER MOTOR REPAIR (Con'

40. Install new gasket (4) and inspection plug (5) on lever housing (3).
41. Install two new gaskets (8) and inspection pi (9) on field frame (2).

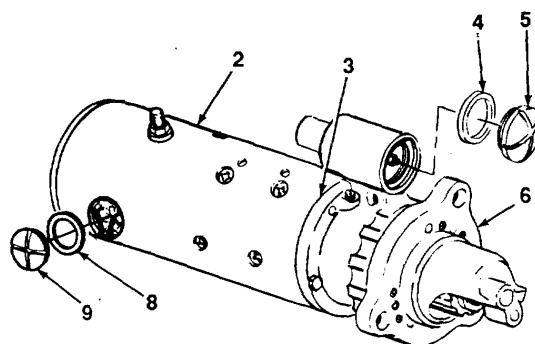
**FOLLOW-ON TASKS:**

- Install starter motor solenoid (see paragraph 5-5).
- Adjust starter motor end play (see paragraph 5-4).

5-4. STARTER MOTOR END PLAY ADJUSTMENT.

This Task Covers: Adjustment

Initial Setup:

Equipment Conditions:

- Starter motor removed (see TM 5-3805-254-20).

Materials/Parts:

- One gasket

Tools/Test Equipment:

- Automotive fuel and electrical system repair tool kit
- Automotive fuel and electrical system shop set

General Safety Instructions:

- Remove all jewelry.

ADJUSTMENT

WARNING

Remove all Jewelry such as dog tags, rings, bracelets, etc. If jewelry contacts any hot electrical terminal, a direct short will result, causing serious Injury or death to personnel.

1. Connect one end of cable (5) on positive terminal (3) of power supply (4) and connect other end of cable on Batt. terminal (7) of solenoid switch (6).
2. Connect one end of cable (1) on negative terminal (2) of power supply (4) and connect other end of cable on housing (10).
3. Connect one end of cable (9) on Mot. terminal (8) of solenoid switch (6) and connect other end of cable on housing (10).
4. Set line switch (14) on power supply (4) to ON. Turn two current knobs (12) clockwise Y turn. Turn two voltage knobs (13) clockwise until voltage Indicator (11) shows 24 volts.

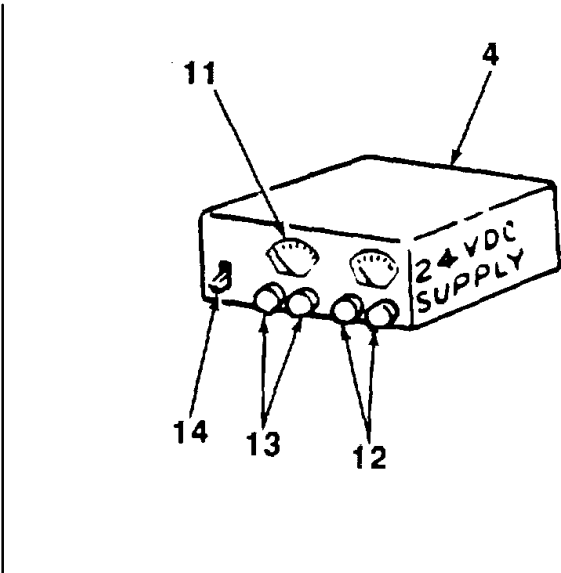
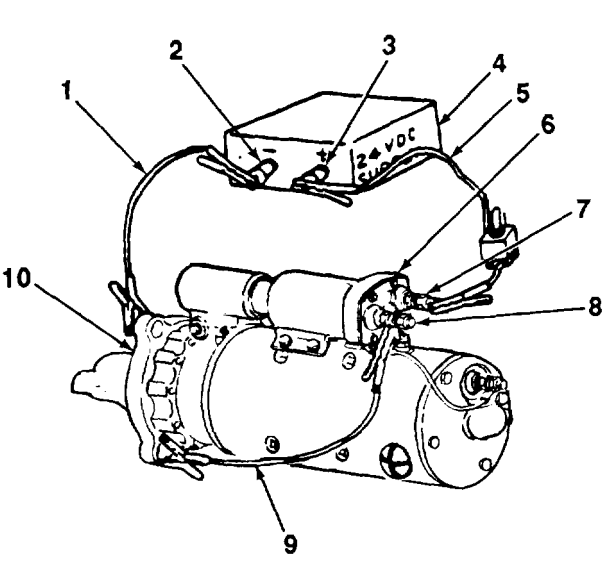

TA703725

5-4. STARTER MOTOR END PLAY ADJUSTMENT (Con't).**CAUTION**

Holding switch to ON for more than 30 seconds will damage switch. Hold switch to ON only long enough to drive clutch motor drive gear against starter housing collar.

5. Hold switch (18) to ON until solenoid switch (6) pushes clutch motor drive gear (21) against starter housing collar (15).
6. Push clutch motor drive gear (21) away from starter housing collar (15) and try to slip 0.040-inch feeler gage between clutch motor drive gear and starter housing collar. If gage slips between clutch motor drive gear and starter housing collar, set switch (18) to OFF.

NOTE

Perform step 7 only if feeler gage did not fit between clutch motor drive gear and starter housing collar.

7. Position 0.030-inch feeler gage between clutch motor drive gear (21) and starter housing collar (15).

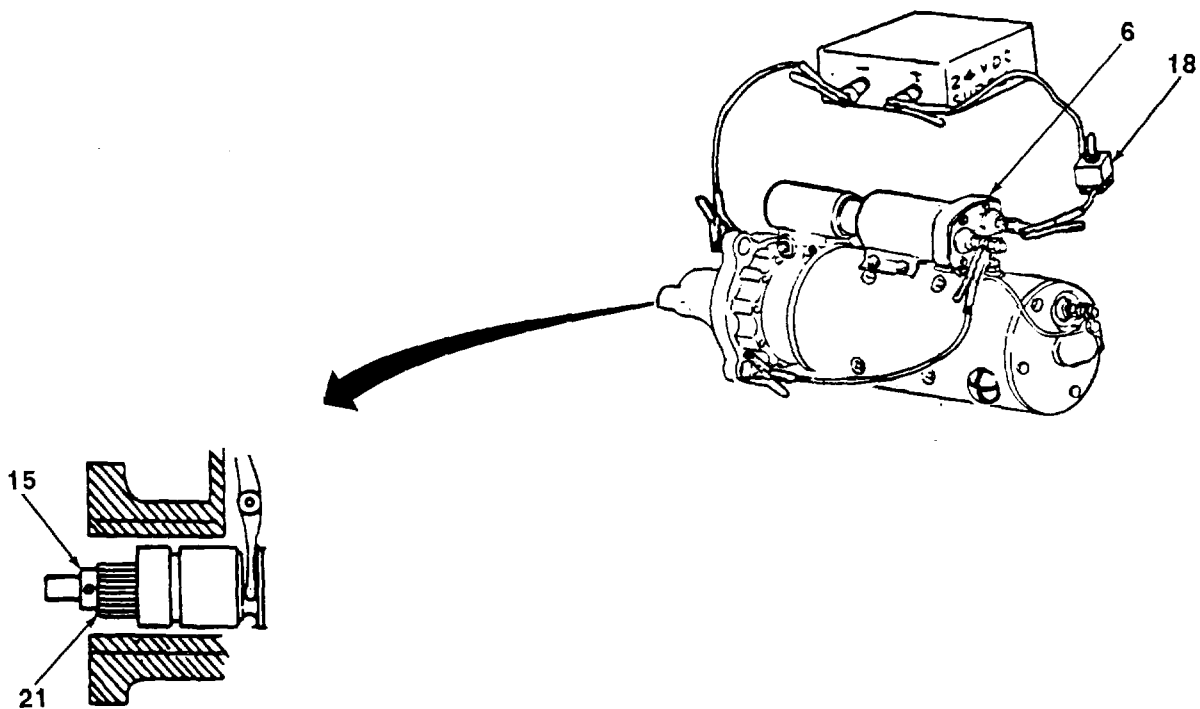

5-4. STARTER MOTOR END PLAY ADJUSTMENT (Con't).**NOTE**

Perform steps 8 through 11 only if 0.040-inch or 0.030-inch feeler gage fits between clutch motor drive gear and starter housing collar.

8. Remove plug (16) and gasket (17) from solenoid switch (6). Discard gasket.
9. Set switch (18) to ON until solenoid switch (6) pushes clutch motor drive gear (21) against starter housing collar (15).
10. Position 0.035-inch feeler gage between clutch motor drive gear (21) and starter housing collar (15) and turn lever nut (20) to point where feeler gage just slips out. Set switch (18) to OFF and turn off power supply. If end play will not adjust, repair starter motor (see paragraph 5-3).
11. Install new gasket (17) and plug (16) on solenoid switch (6).
12. Remove cables (1, 5, and 9) from power supply (4) and motor (19).
13. Perform starter motor test (see paragraph 5-2).

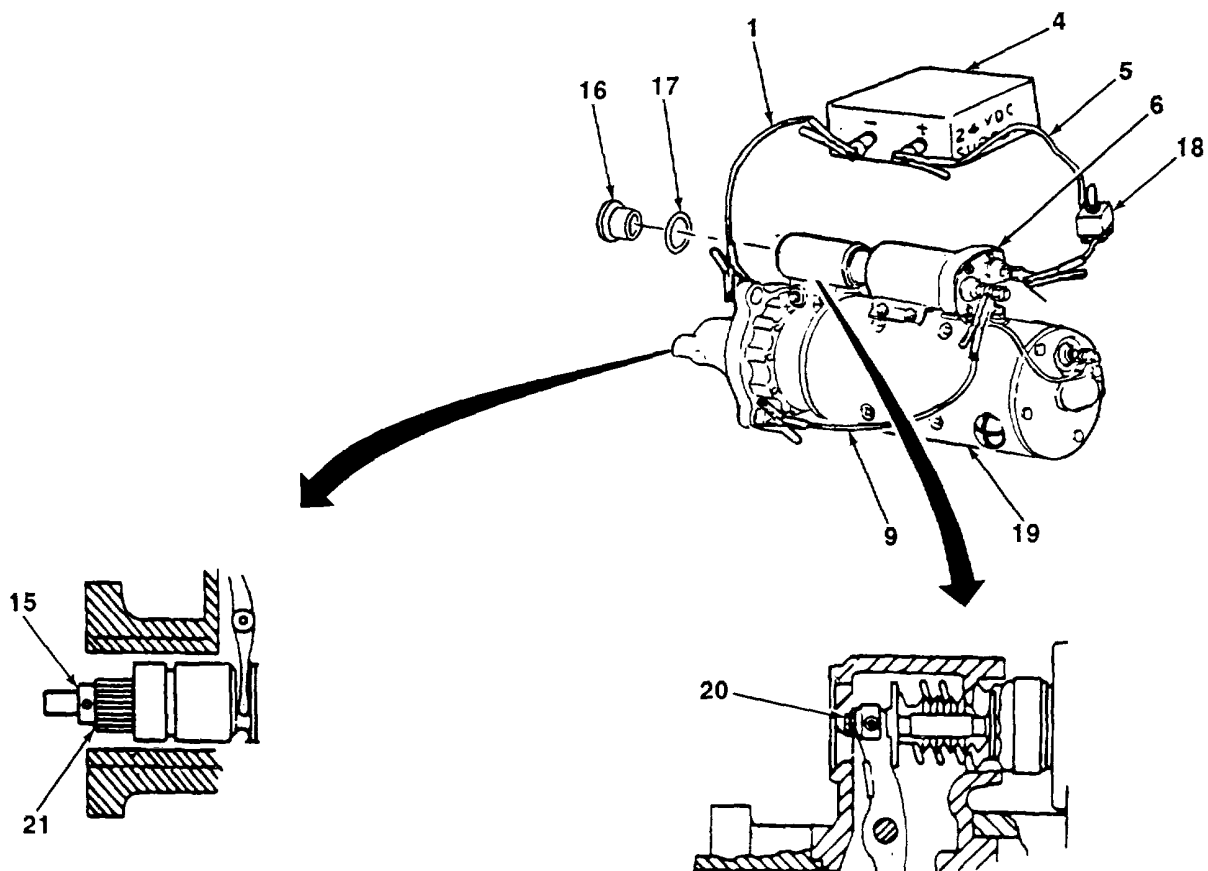

TA703727

5-5. STARTER MOTOR SOLENOID REPLACEMENT.

This Task Covers:

- a. Removal
- b. Installation

Initial Setup:

Equipment Conditions:

- Starter motor removed (see TM 5-3805-254-20).

Materials/Parts:

- Three lockwashers

Tools/Test Equipment:

- Automotive fuel and electrical system repair kit

a. REMOVAL

1. Remove nut (4), lockwasher (3), and ground lead (2) from terminal (1). Discard lockwasher.

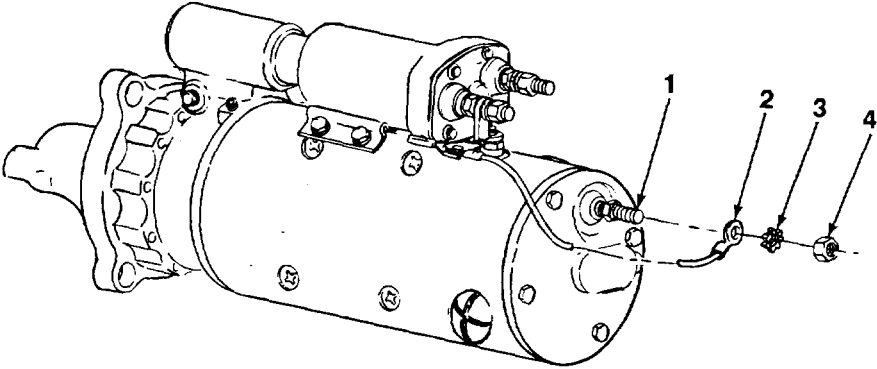

2. Remove nut (8) and lockwasher (7) from terminal (5). Discard lockwasher.
3. Remove nut (9) and lockwasher (10) from terminal (11). Discard lockwasher.
4. Remove connector (6) from two terminals (5 and 11).

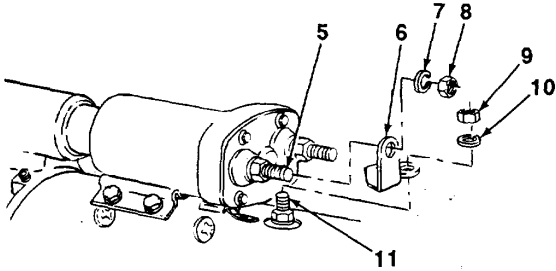

TA703728

5-5. STARTER MOTOR SOLENOID REPLACEMENT (Con't).

5. Remove screw (15), ground lead (14), and clamp (16) from bracket (17).
6. Remove four screws (12) from solenoid (13).
7. Remove solenoid (13) from plunger (18) and starter (19).

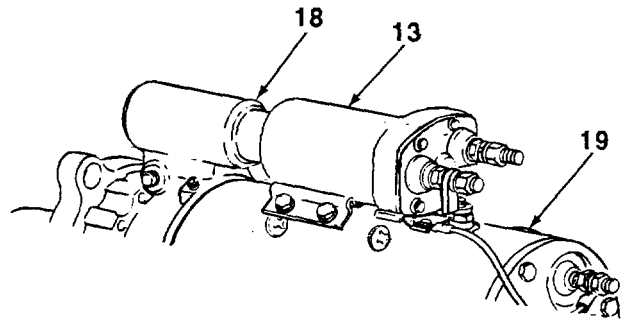
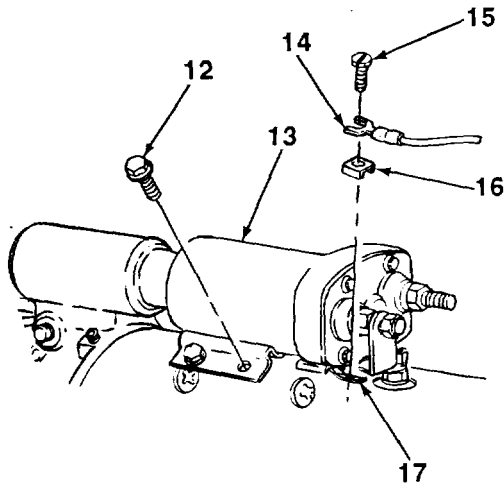

b. INSTALLATION

1. Position solenoid (13) on starter (19) and plunger (18).
2. Install four screws (12) on solenoid (13).
3. Install clamp (16) and ground lead (14) on bracket (17) with screw (15).
4. Position connector (6) on two terminals (5 and 11).
5. Install new lockwasher (10) and nut (9) on terminal (11).
6. Install new lockwasher (7) and nut (8) on terminal (5).

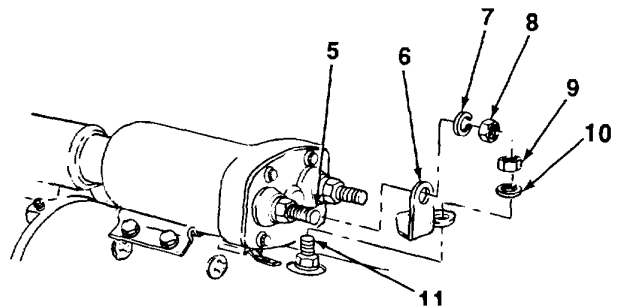

TA703729

5-5. STARTER MOTOR SOLENOID REPLACEMENT (Con't).

7. Install ground lead (2) on terminal (1) with new lockwasher (3) and nut (4).

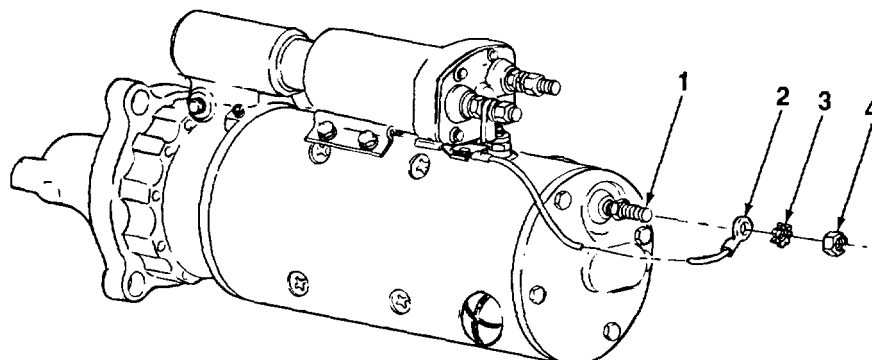
**FOLLOW-ON TASKS:**

- Install starter motor (see TM 5-3805-254-20).

TA703730

5-6. ENGINE, TRANSMISSION, BODY, AND CHASSIS WIRING HARNESS REPLACEMENT.

This Task Covers:

- a. Removal
 - b. Installation
-

Initial Setup:

Equipment Conditions:

- Battery cables disconnected (see TM 5-3805-254-20).

Materials/Parts:

- Marker tags (Item 25, Appendix B)

Tools/Test Equipment:

- General mechanic's tool kit
 - Field automotive shop set
-

a. REMOVAL

1. Refer to wiring diagram (see page FP-1) for routing information and circuit numbers of wiring harness to be removed.

NOTE

- **Tag all wires for Installation (see paragraph 1-16).**
- **Tags must be transferred to wires of new wiring harness to assist in Installation.**

2. Refer to applicable procedure for specific component for removal of wires from components.
3. Note location to assist in Installation and remove all tie wraps, clamps, or other wiring harness retaining devices.

b. INSTALLATION

NOTE

Refer to electrical schematic (see page FP-1) for assistance.

1. Route wiring harness the same location as removed.
2. Install retaining devices, clamps, and tie wraps as noted in removal.
3. Connect wiring harness wires to components as tagged.
4. Remove tags.

FOLLOW-ON TASKS:

- Connect battery cables (see TM 5-3805-254-20).

5-7. WIRING DIAGRAM.

Refer to the wiring diagram on page FP-1, Figure FO-1 at the back of the manual.

5-8. JACOBS EXHAUST BRAKE WIRING HARNESS REPLACEMENT.

This Task Covers:

- a. Removal
- b. Installation

Initial Setup:

Equipment Conditions:

- Battery ground cable disconnected (see TM 5-3805-254-20).
- Left side hood opened (see TM 5-3805-254-10).
- Upper center Instrument panel opened (see TM 5-3805-254-20).

Materials/Parts:

- Tie-down straps (Item 24, Appendix B)
- Marker tags (Item 25, Appendix B)

References:

- TM 5-3805-254-20

Tools/Test Equipment:

- General mechanic's tool kit
- Field automotive shop set

a. REMOVAL

1. Disconnect wires from compression brake 15 amp circuit breaker (see TM 5-3805-254-20).
2. Disconnect wires from compression brake switch (see TM 5-3805-254-20).
3. Disconnect wires from engine water temperature switch (see TM 5-3805-254-20).

5-8. JACOBS EXHAUST BRAKE WIRING HARNESS REPLACEMENT (Con't).

4. Remove two screws (10) and clamps (9) from engine covers (4).
5. Disconnect three connectors (2) from engine connections (3).
6. Note location of 12 tie-down straps (8) to assist in installation and remove tie-down straps securing harness assemblies (6 and 7). Discard tie-down straps.
7. Remove harness assemblies (6 and 7) from vehicle.

NOTE

Keep wires of harness assembly being replaced to use as a template to make new harness assembly.

8. If replacing either harness assembly (6 or 7), remove all connectors (1) and terminal lugs (5 and 11) from harness to be replaced.

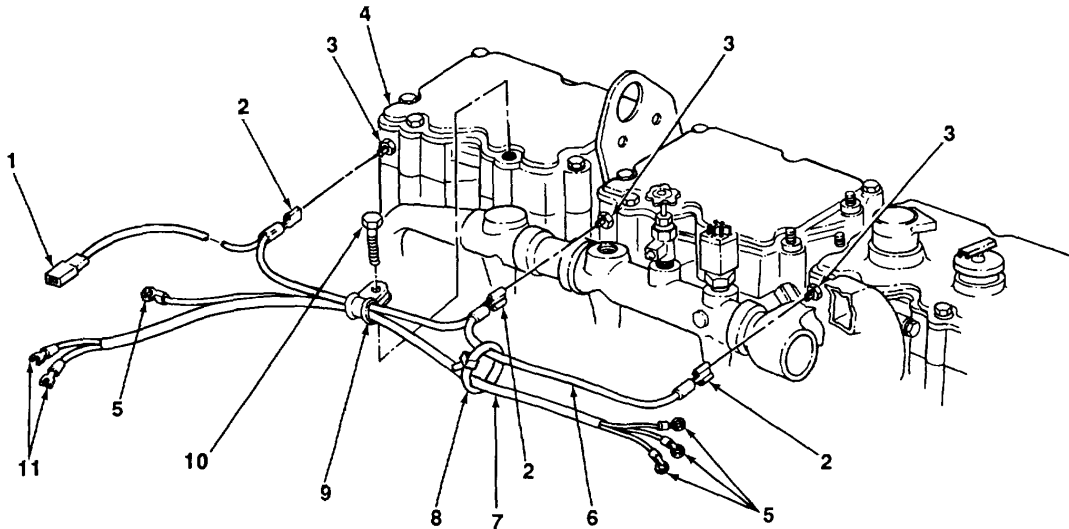
**b. INSTALLATION****NOTE**

Perform steps 1 through 3 only if replacing harness assembly.

1. Use wires from old harness assembly (6 or 7) as a template and cut new wires to same length.

TA703731

5-8. JACOBS EXHAUST BRAKE WIRING HARNESS REPLACEMENT (Con't).

2. Install three connectors (2) and connector (1) on new wires if replacing harness assembly (6).
3. Install three terminal lugs (5) and two lugs (11) on new wires if replacing harness assembly (7).
4. Install harness assemblies (6 and 7) on engine covers (4) with two clamps (9) and screws (10).
5. Connect three connectors (2) of harness assembly (6) to engine connections (3).
6. Install 12 new tie-down straps (8) to secure harness assemblies (6 and 7) to vehicle.
7. Connect wires to engine water temperature switch (see TM 5-3805-254-20).
8. Connect wires to compression brake switch (see TM 5-3805-254-20).
9. Connect wires to compression brake 15 amp circuit breaker (see TM 5-3805-254-20).

FOLLOW-ON TASKS:

- Close upper center instrument panel (see TM 5-3805-254-20).
- Connect battery ground cable (see TM 5-3805-254-20).
- Close left side hood (see TM 5-3805-254-10).

5-41/(5-42 Blank)

CHAPTER 6
TRANSMISSION AND AUXILIARY TRANSMISSION MAINTENANCE

Paragraph Number	Paragraph Title	Page Number
6-1	Auxiliary Transmission Replacement	6-2
6-2	Auxiliary Transmission Repair	6-7
6-3	Auxiliary Transmission Top Cover Maintenance	6-28
6-4	Auxiliary Transmission Linkage Replacement	6-33
6-5	Transmission Cooler Hoses and Fittings Replacement	6-39
6-6	Torque Converter Cooler Maintenance	6-42
6-7	Transmission Modulator Valve Maintenance	6-51
6-8	Transmission Replacement	6-58
6-9	Install and Remove Transmission from Overhaul Stand	6-62
6-10	Flywheel Replacement	6-64
6-11	Torque Converter Replacement	6-72
6-12	Trimmer Valve Replacement	6-80
6-13	Low Shift Valve Replacement	6-82
6-14	Control Valve Replacement	6-83
6-15	Oil Pump, Front Support, and Converter Housing Replacement	6-86
6-16	Input Shaft and Forward Clutch Replacement	6-94
6-17	Fourth Clutch Replacement	6-96
6-18	Third Clutch Replacement	6-97
6-19	Output Housing Replacement	6-99
6-20	Low Planetary Carrier Replacement	6-101
6-21	Low Ring Gear and Low Clutch Replacement	6-102
6-22	Adapter Housing Replacement	6-104
6-23	First Clutch and Ring Gear Replacement	6-105
6-24	Center Support Replacement	6-109
6-25	Gear Unit Replacement	6-112
6-26	Second Clutch Replacement	6-114
6-27	Transmission Housing Repair	6-117
6-28	Oil Pump Repair	6-120
6-29	Front Support Repair	6-122
6-30	Forward Clutch Repair	6-127
6-31	Fourth Clutch Repair	6-140
6-32	Low Trimmer Valve Repair	6-147
6-33	Low Shift Valve Repair	6-149
6-34	Control Valve Repair	6-151
6-35	Governor Assembly Replacement	6-171
6-36	Transmission Output Shaft Oil Seal Replacement	6-172
6-37	Output Housing Repair	6-173
6-38	Low Planetary Carrier Repair	6-179
6-39	Adapter Housing Repair	6-182
6-40	Gear Unit Repair	6-186
6-41	Center Support Repair	6-201

6-1. AUXILIARY TRANSMISSION REPLACEMENT.

This Task Covers:

- a. Removal
- b. Installation

Initial Setup:

Equipment Conditions:

- Auxiliary transmission drained (see TM 5-3805-254-20).
- Speedometer drive cable disconnected (see TM 5-3805-254-20).
- Auxiliary transmission linkage disconnected (see paragraph 6-4).
- Transmission to auxiliary transmission propeller shaft removed (see paragraph 7-1).
- Auxiliary transmission to interaxle differential propeller shaft removed (see paragraph 7-1).

Materials/Parts:

*Thirteen locknuts

Tools/Test Equipment:

- General mechanic's tool kit
- Field automotive shop set

Personnel Required: Two

a. REMOVAL

1. Position transmission floor Jack under auxiliary transmission (5) and raise transmission floor Jack to support auxiliary transmission.

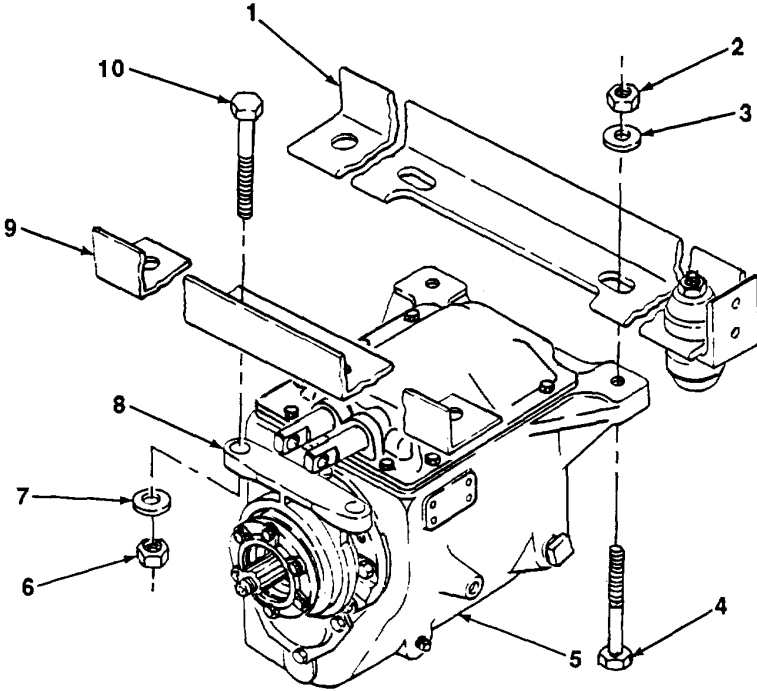

TA703732

6-1. AUXILIARY TRANSMISSION REPLACEMENT (Con't).**WARNING**

Auxiliary transmission is heavy. DO NOT remove nuts and screws unless auxiliary transmission is supported. Failure to follow this warning may result in injury or death to personnel.

2. Remove two locknuts (6), washers (7), and screws (10) holding trunnion (8) to front transmission support (9). Discard locknuts.
3. Remove two nuts (2), washers (3), and screws (4) holding auxiliary transmission (5) to rear transmission support (1).
4. Lower auxiliary transmission (5).
5. Remove spacer (11) and trunnion (8) from auxiliary transmission (5).
6. Remove lube fitting (12) from trunnion (8).

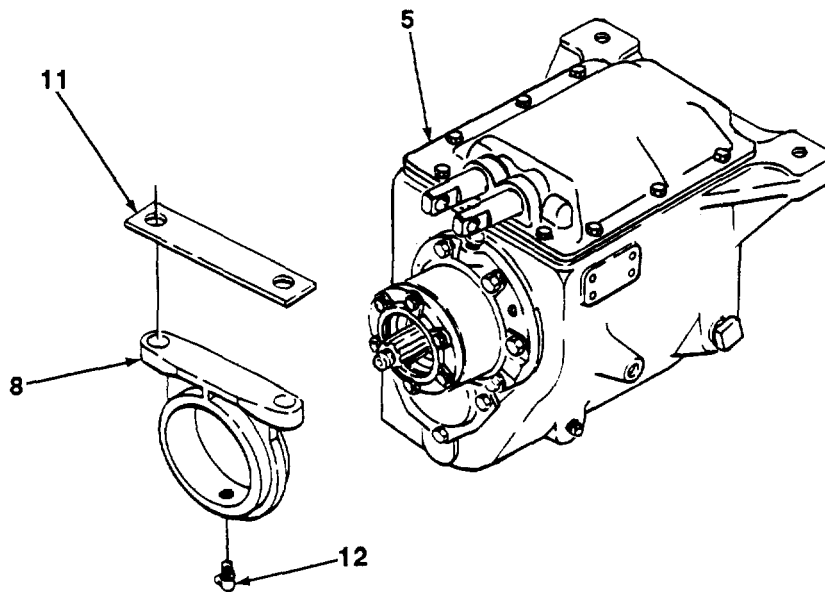

TA703733

6-1. AUXILIARY TRANSMISSION REPLACEMENT (Con't).

- 7. Remove four locknuts (13), screws (17), washers (18), eight insulators (14), four spacer sleeves (15), front transmission support (9), and rear transmission support (1) from four angles (19). Discard locknuts.

NOTE
Perform step 8 for angle toward right rear of vehicle frame.

- 8. Remove two locknuts (20), one screw (16), and angle (19) from vehicle frame. Discard locknuts.

NOTE
Perform step 9 for each of three remaining angles.

- 9. Remove two locknuts (20), screws (16), and angle (19) from vehicle frame. Discard locknuts.

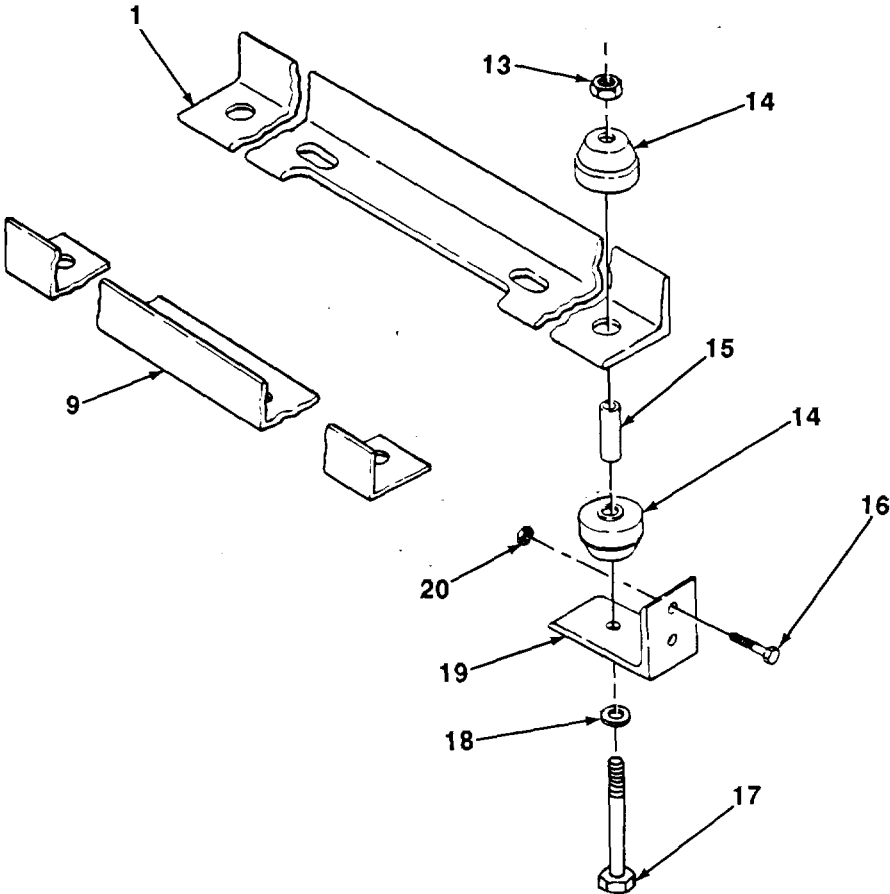

TA703734

6-1. AUXILIARY TRANSMISSION REPLACEMENT (Con't).**b. INSTALLATION****NOTE**

Perform step 1 for angle toward right rear of vehicle frame.

1. Install angle (19) to vehicle frame with one screw (16) and two new locknuts (20).

NOTE

Perform step 2 for each of three remaining angles.

2. Install angle (19) to vehicle frame with two screws (16) and new locknuts (20).
3. Install rear transmission support (1) and front transmission support (9) to four angles (19) with four spacer sleeves (15), eight insulators (14), four washers (18), screws (17), and new locknuts (13).
4. Install lube fitting (12) to trunnion (8).
5. Install trunnion (8) to front of auxiliary transmission (5).
6. Install spacer (11) on top of trunnion (8).

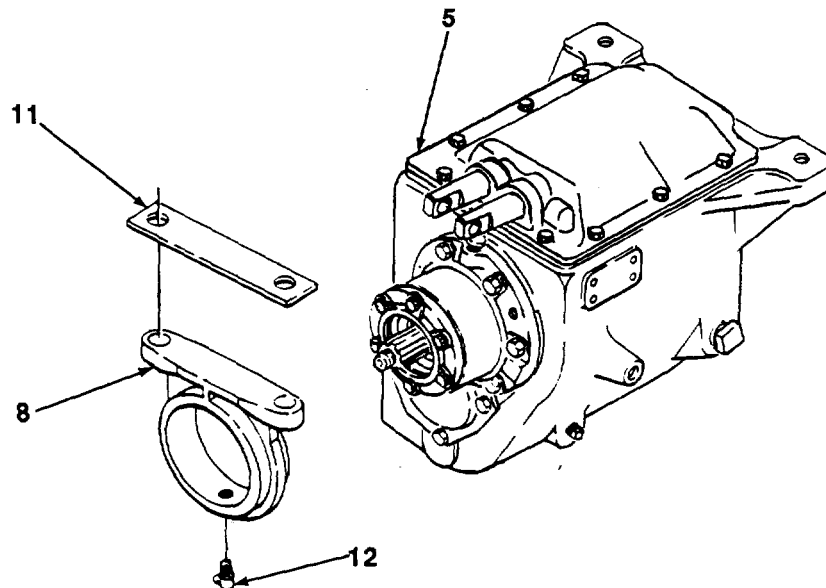

TA703735

6-1. AUXILIARY TRANSMISSION REPLACEMENT (Con't).**WARNING**

Auxiliary transmission is heavy. Handle carefully to avoid injury or damage. Failure to follow this warning may result in injury or death to personnel.

7. Raise auxiliary transmission (5) upward and install trunnion (8) to front transmission support (9) with two screws (10), washers (7), and new locknuts (6).
8. Install auxiliary transmission (5) to rear transmission support (1) with two screws (4), washers (3), and nuts (2).

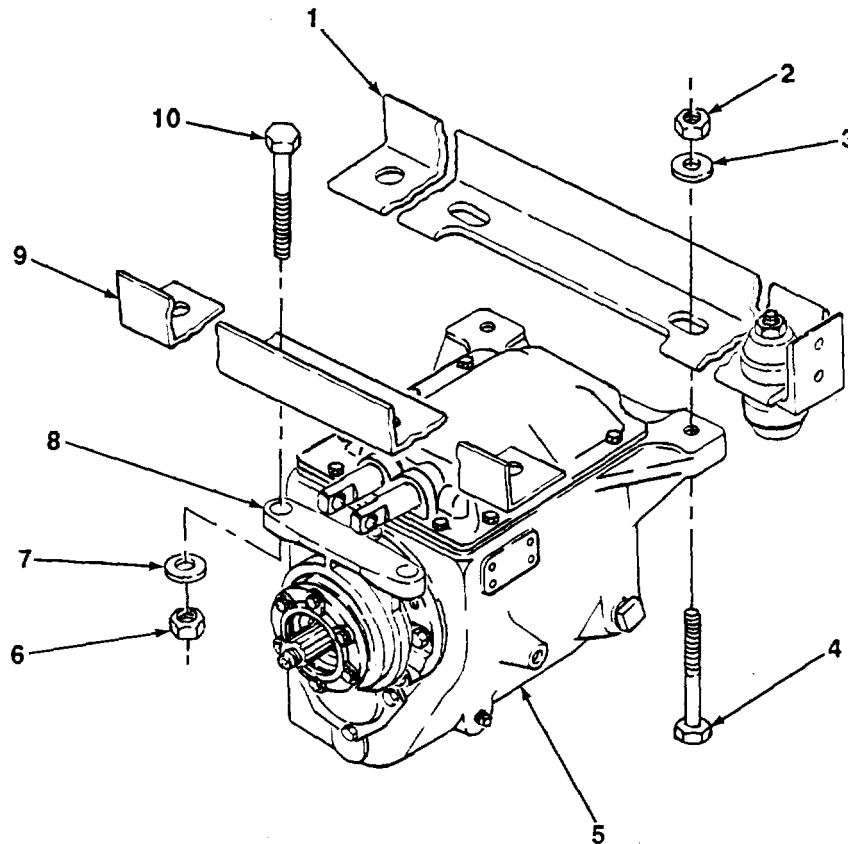
**FOLLOW-ON TASKS:**

- Install auxiliary transmission to interaxle differential propeller shaft (see paragraph 7-1).
- Install transmission to auxiliary transmission propeller shaft (see paragraph 7-1).
- Connect auxiliary transmission linkage (see paragraph 6-4).
- Connect speedometer drive cable (see TM 5-3805-254-20).
- Fill auxiliary transmission (see TM 5-3805-254-20).

TA703736

6-2. AUXILIARY TRANSMISSION REPAIR.

This Task Covers:

- | | | | |
|----|-------------------------|----|----------|
| a. | Disassembly | c. | Assembly |
| b. | Cleaning and Inspection | | |

Initial Setup:

Equipment Conditions:

- Auxiliary transmission removed (see paragraph 6-1).
- Lubricating oil (Item 13, Appendix B)

Tools/Test Equipment:

- General mechanic's tool kit
- Field automotive shop set
- Forty lockwashers

Materials/Parts:

- Grease (Item 10, Appendix B)
- Sealant compound (Item 19, Appendix B)
- Dry cleaning solvent (Item 23, Appendix B)
- Three parts kits

General Safety Instructions:

- Dry cleaning solvent is flammable and must not be used near open flame, Use only in a well-ventilated area.

a. ASSEMBLY**NOTE**

* Perform steps 1 through 9 to disassemble top cover housing.

* Auxiliary transmission is in neutral when shaft and shift bar protrude evenly from case.

1. Using shaft (1) and shift bar (3), shift auxiliary transmission (2) into neutral.

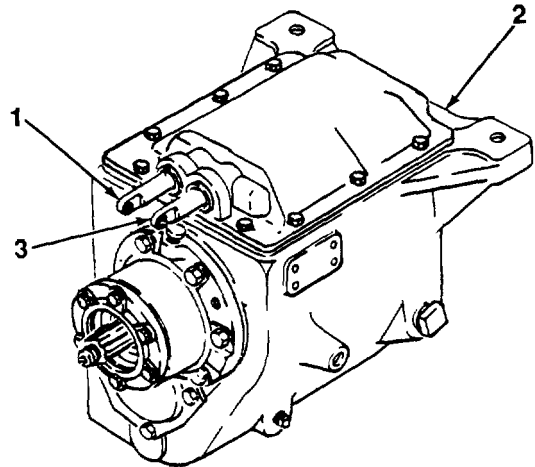

TA703737

6-2. AUXILIARY TRANSMISSION REPAIR

2. Remove ten bolts (4), lockwashers (5), housing (6), and gasket (7) from top of case (8). Discard lockwashers and gasket.

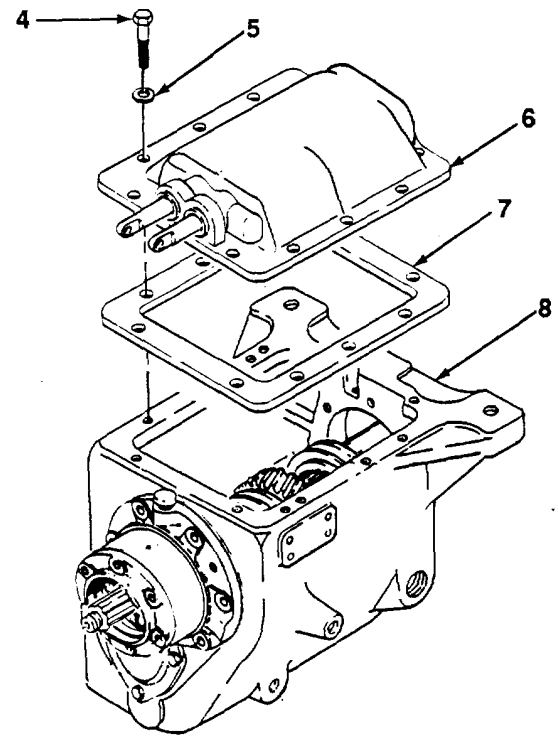

3. Remove retainer (9), spring (10), plunger (11), and ball (12) from housing (6). Discard spring, plunger, and ball.
4. Remove screw (16) from shift fork (15) and pull shaft (1) partially out of housing (6) to remove stop sleeve (14) and shift fork. Discard screw.
5. Remove screw (17) from shift fork (18). Discard screw.

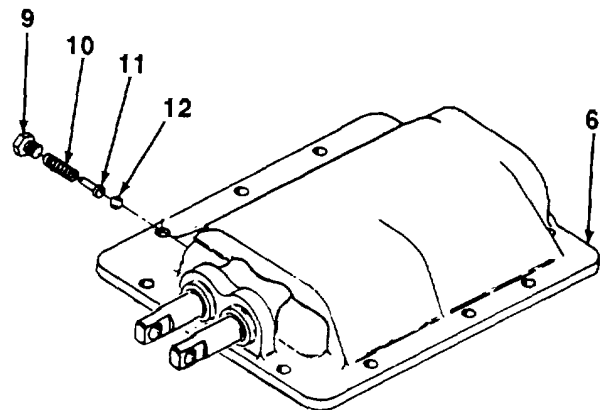
**CAUTION**

Interlock and ball will fall free as shaft is removed from housing. DO NOT lose or damage Interlock and ball.

6. Remove shaft (1), interlock (22), and ball (21) from housing (6). Discard interlock and ball.
7. Remove plunger (20) and spring (19) from housing (6). Discard plunger and spring.
8. Remove shift bar (3) from housing (6).
9. Remove two oil seals (13). Discard oil seals.

TA703738

6-2. AUXILIARY TRANSMISSION REPAIR (Con't).

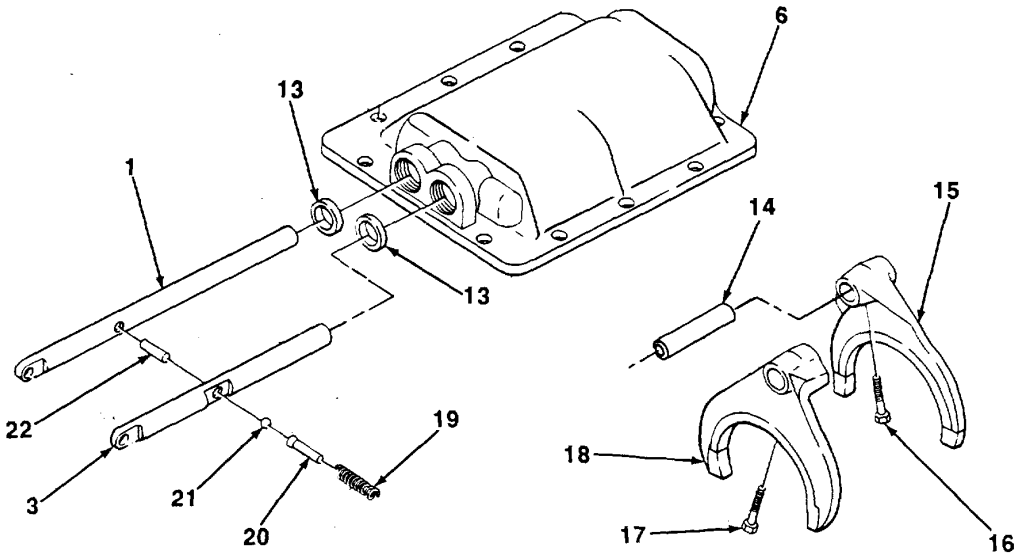

NOTE

Perform steps 10 through 43 to disassemble auxiliary transmission case.

- 10. Remove nut (23) and washer (24) from end of case (8).
- 11. Remove six bolts (25), lockwashers (26), bearing retainer (27), and gasket (28) from retainer (29). Discard lockwashers and basket.

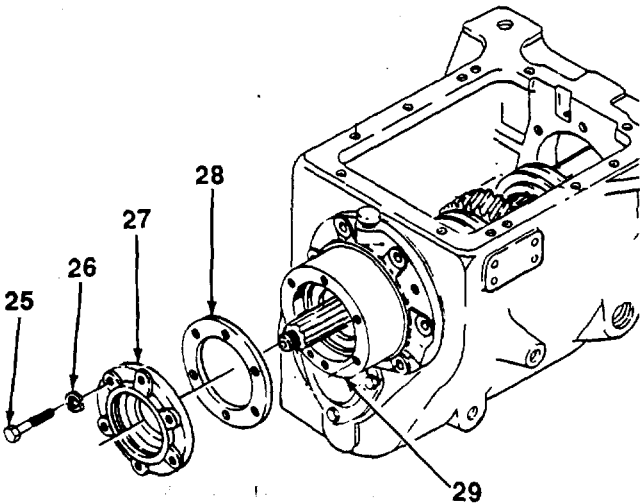
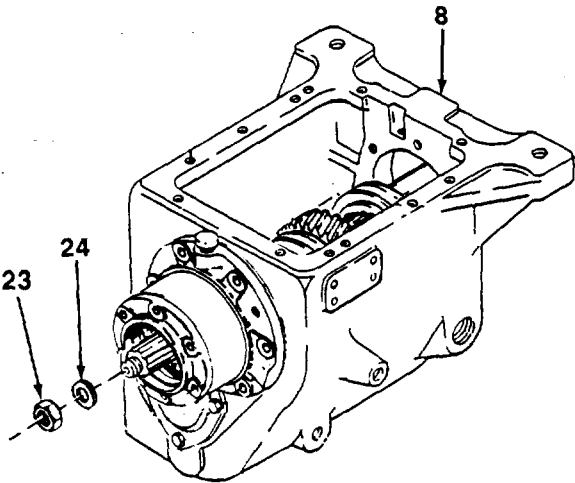

TA703739

6-2. AUXILIARY TRANSMISSION REPAIR (Con't)

- 12. Remove seal (30) from bearing retainer (27). Discard seal.

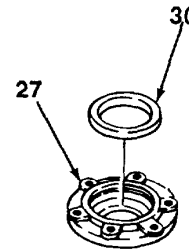

- 13. Remove breather (31) from retainer (29).
- 14. Mark position of retainer (29) on case (8) for assembly.

- 15. Remove six bolts (35) and lockwashers (34). Discard lockwashers.

- 16. Using puller, remove retainer (29) from drive gearshaft (33). Remove gasket (32). Discard gasket.

- 17. Using puller, remove bearing (36) from front of retainer (29). Discard bearing.

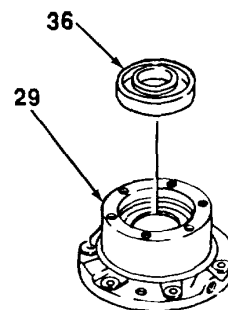
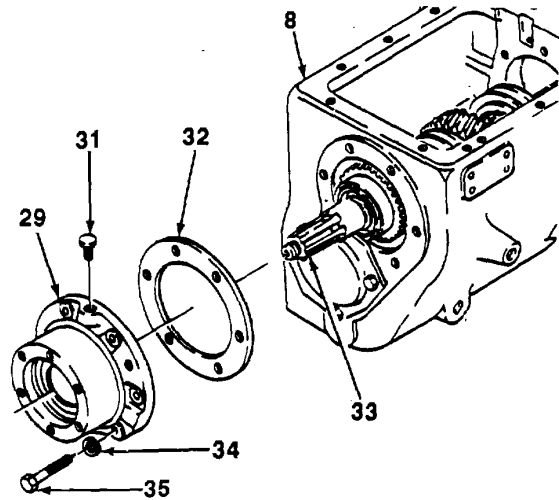

6-2. AUXILIARY TRANSMISSION REPAIR (Con't).

18. Remove two long screws (40) and lockwashers (39) from bearing retainer (38). Discard lockwashers.
19. Remove four screws (42), lockwashers (43), bearing retainer (38), and gasket (37) from case (8). Discard lockwashers and gasket.
20. Remove seal (41) from bearing retainer (38). Discard seal.

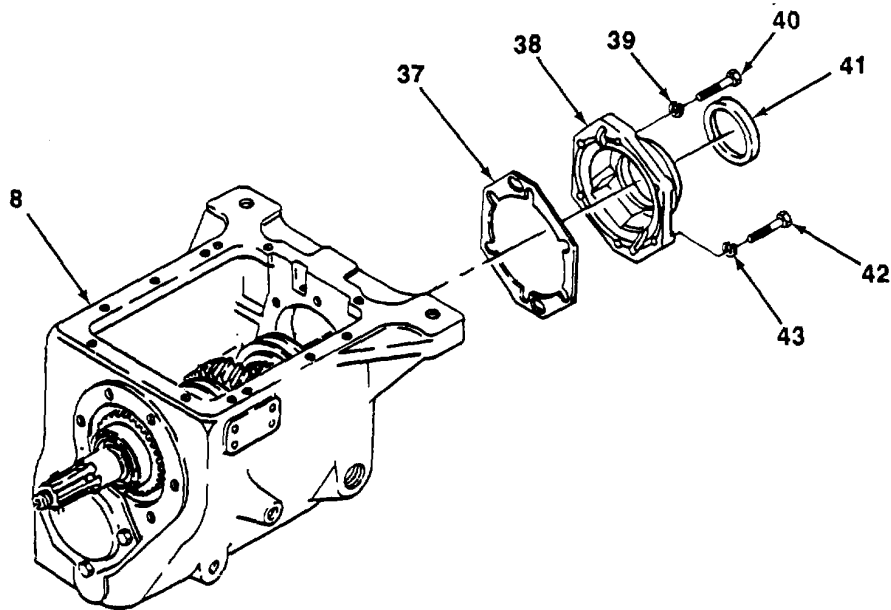

21. Remove two screws (44), lockwashers (45), flange (46), gear (47), and bushing (48) from bearing retainer (38). Discard lockwashers.

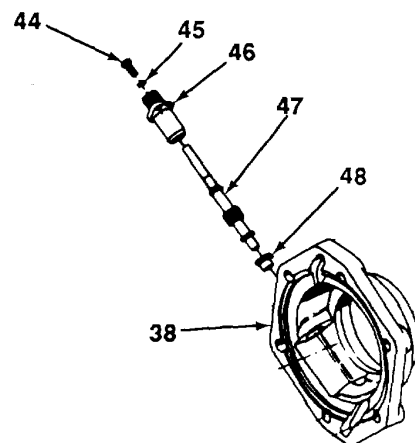

TA703741

6-2. AUXILIARY TRANSMISSION REPAIR

22. Remove speedometer drive gear (51) and washer (50) from rear of mainshaft (49).

NOTE

Perform steps 23 and 24 to expose retainer ring at front of mainshaft.

23. Pull drive gearshaft (33) with bearing (53) fully forward.
24. Drive mainshaft (49) forward until collar (52) contacts rear of drive gearshaft (33).

NOTE

Perform either step 25 or 26 to remove retainer ring from front of mainshaft.

25. Pry retainer ring (54) upward to remove retainer ring. Discard retainer ring.
26. Press downward on ends of retainer ring (54) and allow retainer ring to drop into bottom of case (8). Discard retainer ring.
27. Using two pry bars, move mainshaft (49) assembly to rear of case (8).

28. Using puller attached to snapping of ball bearing (56), remove ball bearing from case (8). Discard ball bearing.

29. Remove thrustwasher (55). Discard thrustwasher.

30. While pulling mainshaft (49) through rear of case (8), remove collar (58), gear (57), sleeve (59), gear (61), bearing (60), sleeve (62), collar (52), gear (63), gear (65), and bearing (64) out through top of case (8). Discard bearings.

31. Remove drive gearshaft (33) through top of case (8).

32. Remove outer race of bearing (53) from drive gearshaft (33). Discard outer race.

33. Remove bearing (66) from rear of drive gearshaft (33). Discard bearing.

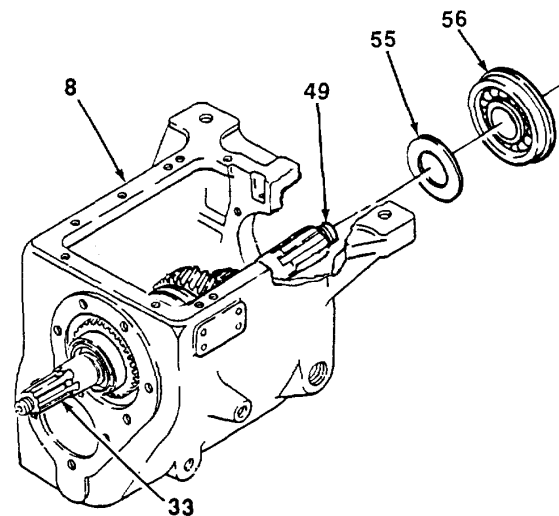
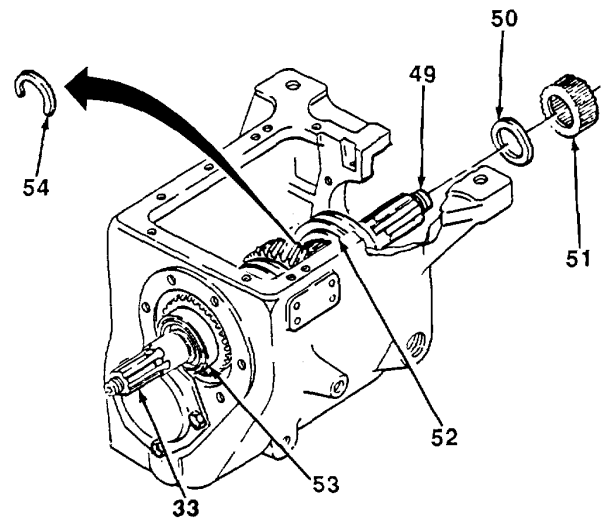

TA703742

6-2. AUXILIARY TRANSMISSION REPAIR (Con't).

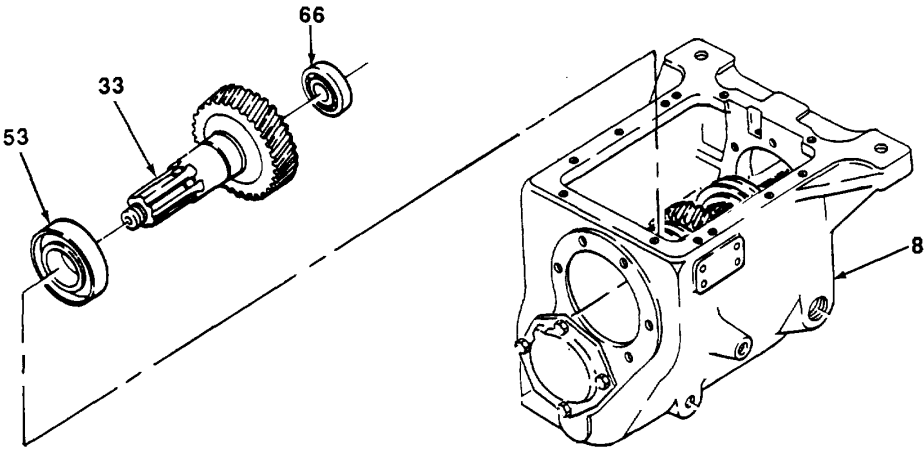
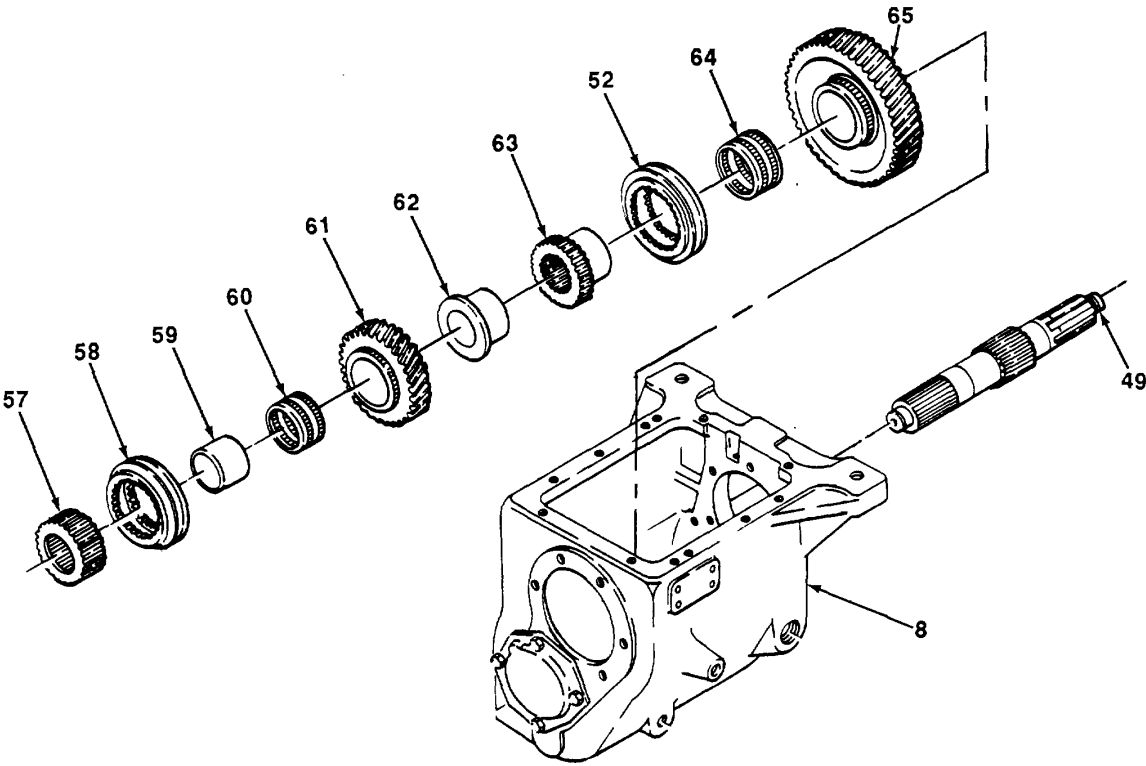

6-2. AUXILIARY TRANSMISSION REPAIR (Con't).**NOTE**

Perform step 34 at each end of case.

34. Remove four bolts (74), lockwashers (73), retainer (67), and gasket (68). Discard lockwashers and gasket.

NOTE

Countershaft bearing at rear of case will be forced out of case.

35. Using pry bar against gear (69), move countershaft (71) rearward far enough to remove countershaft from countershaft bearing (72 at front of case (8)).

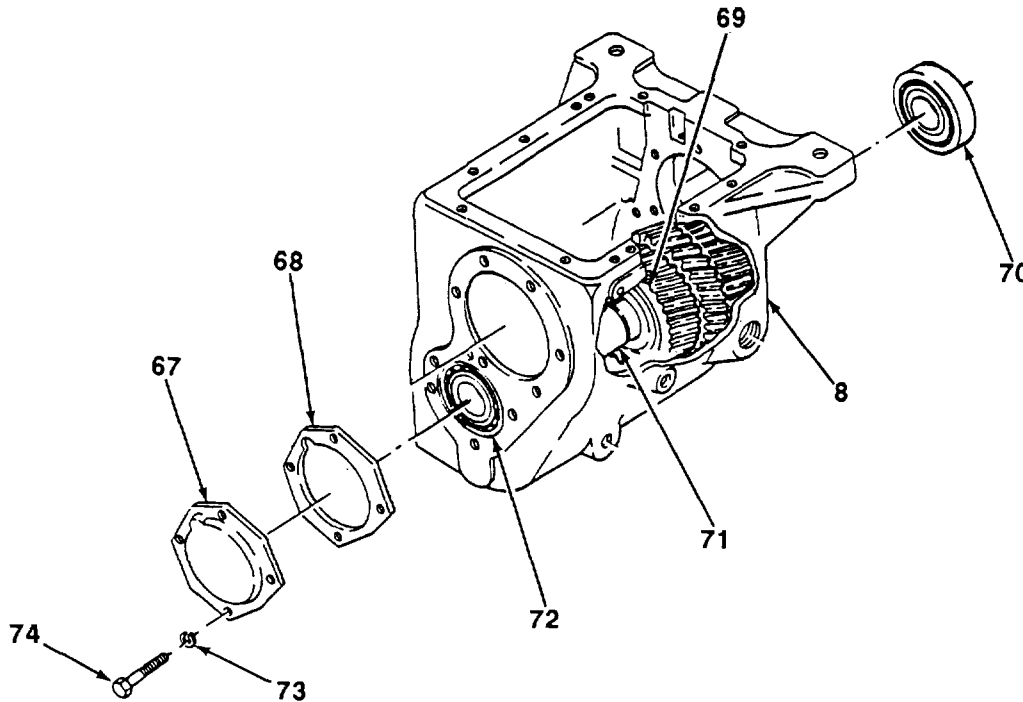

36. Remove countershaft bearing (70) at rear of countershaft (71). Discard outer race.
37. Remove countershaft (71) out through top of case (8).
38. Drive countershaft bearing (72) from front of case (8). Discard outer race.
39. Remove retainer ring (75) from countershaft (71). Discard retainer ring.
40. Press gear (69) and gear (76), one at a time, off countershaft (71).
41. Remove two woodruff keys (78) and retainer ring (77). Discard retainer ring.

TA703744

6-2. AUXILIARY TRANSMISSION REPAIR (Con't).

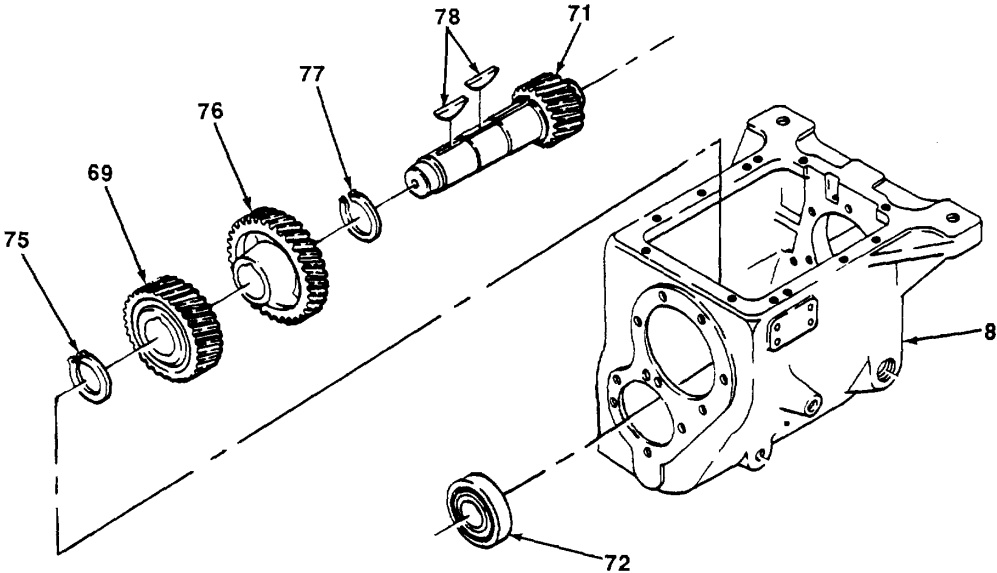

- 42. Remove eight bolts (79), PTO cover (80), and gasket (81) from case (8). Discard gasket.
- 43. Remove two plugs (82) filler plug (83), plug (84) drain plug (85) and pipe plug (86).

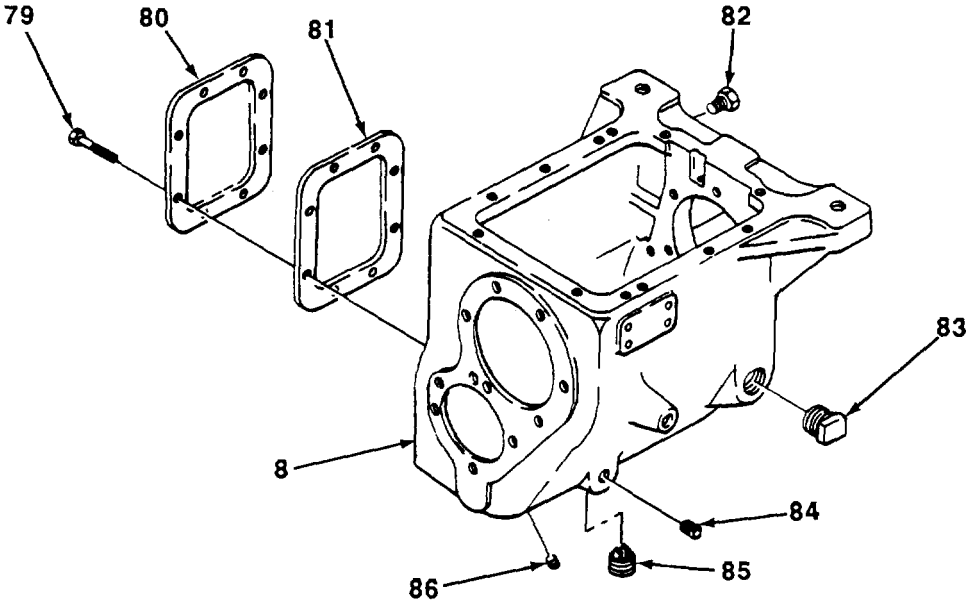

6-2. AUXILIARY TRANSMISSION REPAIR (Con't).**b. CLEANING AND INSPECTION****WARNING**

Dry cleaning solvent, P-D-680, is toxic and flammable. Always wear protective goggles and gloves, and use only in a well-ventilated area. Avoid contact with skin, eyes, and clothes, and DO NOT breathe vapors. DO NOT use near open flame or excessive heat. The solvent's flash point is 100°F-138°F (38°C-59°C). If you become dizzy while using cleaning solvent, immediately get fresh air and medical help. If solvent contacts eyes, immediately wash your eyes and get medical aid.

1. Clean interior metal parts with dry cleaning solvent.
2. Clean external metal parts with dry cleaning solvent or steam. Dry thoroughly.
3. Inspect metal parts for cracks, breaks, wear, and other damage. Replace if damaged.
4. Inspect bearings for wear or damage. Replace if damaged.
5. Inspect gears for chipped, worn, or broken teeth.

c. ASSEMBLY**NOTE**

Perform steps 1 through 52 to assemble auxiliary transmission case.

1. Apply thin coat of sealant compound to threads of pipe plug (86), drain plug (85), plug (84), filler plug (83) and two plugs (82), and install into case (8).

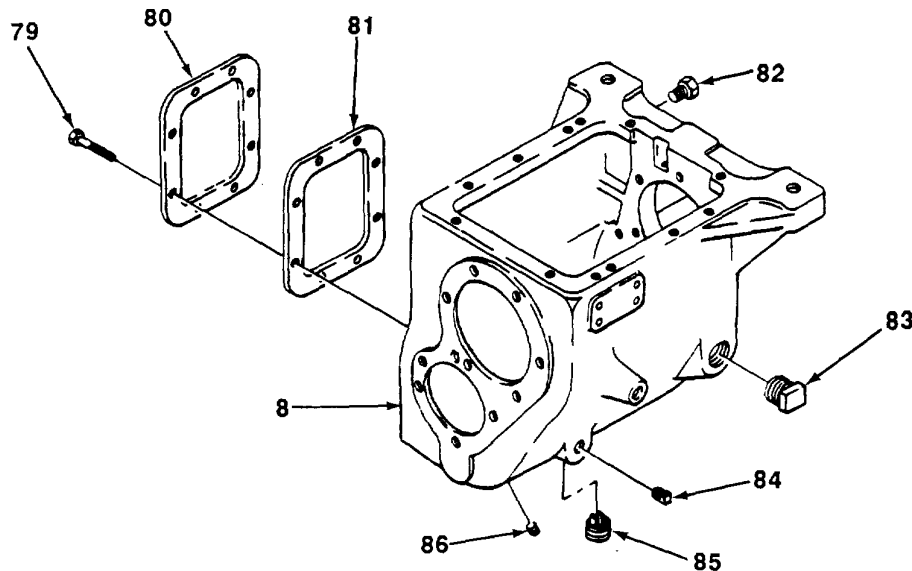

TA703746

6-2. AUXILIARY TRANSMISSION REPAIR (Con't).

2. Install new gasket (81) and PTO cover (80) with eight bolts (79).
3. Apply thin coat of lubricating oil to all interior parts of auxiliary transmission.
4. Install new retainer ring (77) and two woodruff keys (78) to countershaft (71).

NOTE

Gears are Installed on countershaft side of gear bore first.

5. Press gear (76) and gear (69), one at a time, on countershaft (71) until fully seated.
6. Install new retainer ring (75).
7. Install new outer race of countershaft bearing (72) into front of case (8) with 0.02 in. (0.51 mm) of bearing race protruding from front of case.

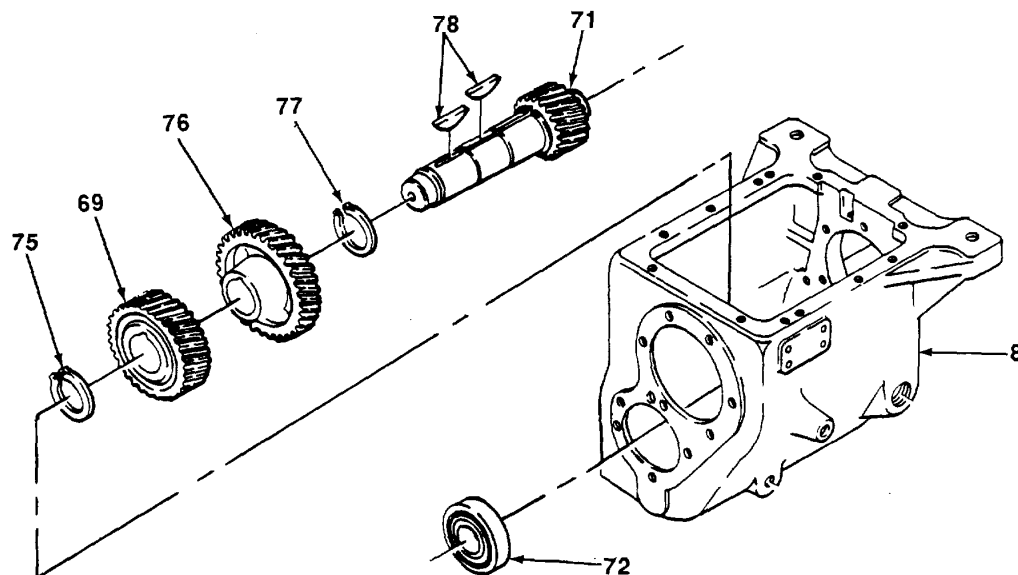

TA703747

6-2. AUXILIARY TRANSMISSION REPAIR (Con't).

8. Install countershaft bearing (70) to end of countershaft (71).
9. Install countershaft (71) into case (8).
10. Ensure outer bearing race of countershaft bearing (72) is installed in case (8) with 0.02 in. (0.51 mm) of bearing race protruding from rear of case

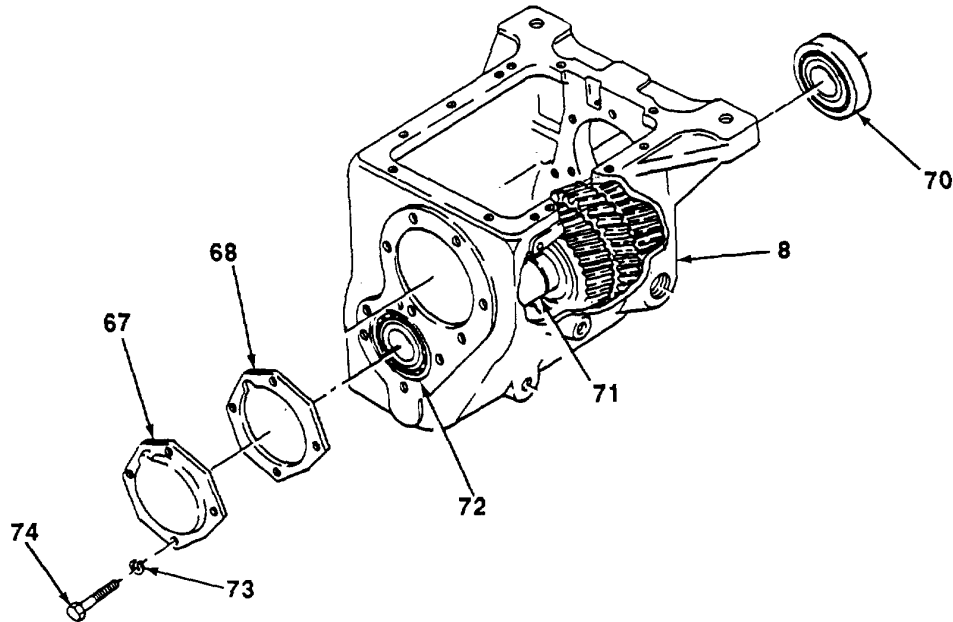
**NOTE**

Perform steps 11 and 12 at each end of case.

11. Apply thin coat of sealant compound to threads of four bolts (74) and both sides of new gasket (68).
12. Install new gasket (68) and retainer (67) to case (8) with four new lockwashers (73) and bolts (74). Torque bolts to 25-32 lb.-ft. (34-43 N-m).

TA703748

6-2. AUXILIARY TRANSMISSION REPAIR (Con't).

13. Install new outer race of bearing (53) into front of case (8) with flanged end of outer race facing away from case.
14. Press new inner race of bearing (53) onto drive gearshaft (33) with flange of inner race fully seated against gear of drive gearshaft.
15. Install new bearing (66) into rear of drive gearshaft (33) with flanged end of inner race facing away from gear.
16. Install drive gearshaft (33) in case (8).
17. Install drive gearshaft (33) forward through outer race of bearing (53).

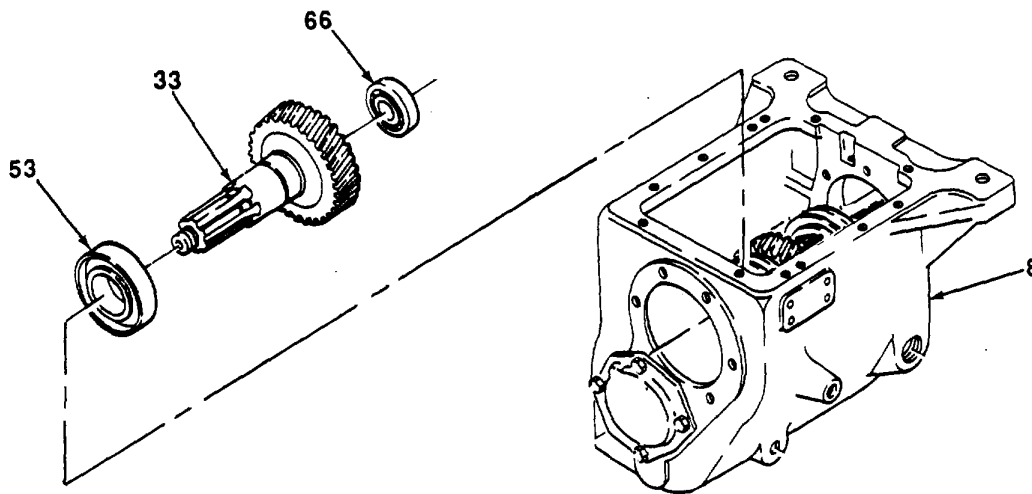

TA703749

6-2. AUXILIARY TRANSMISSION REPAIR (Con't).

18. Place gear (63) on work surface with flange facing downward.

CAUTION

Ensure that grease does not plug oil holes in gear.

19. Apply coat of grease to surface of gear (63) above flange.
20. Install new bearing (64) on gear (63).
21. Install gear (65) over bearing (64) with clutch teeth of gear facing flange of gear (63). Set aside.
22. Apply coat of grease to outer surface of sleeve (59).
23. Install new bearing (60) on sleeve (59).
24. Install gear (61) over bearing (60). Set aside.

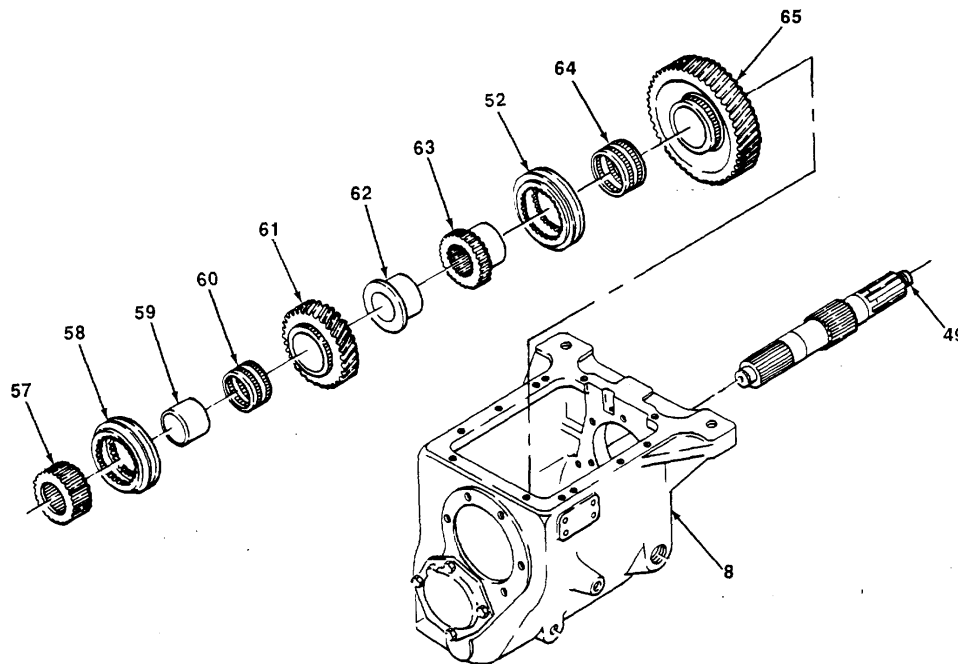

TA703750

6-2. AUXILIARY TRANSMISSION REPAIR (Con't).

25. Position gear (65) down into case (8) with clutch teeth of gear facing front of case and outer teeth of gear meshing with countershaft (71).

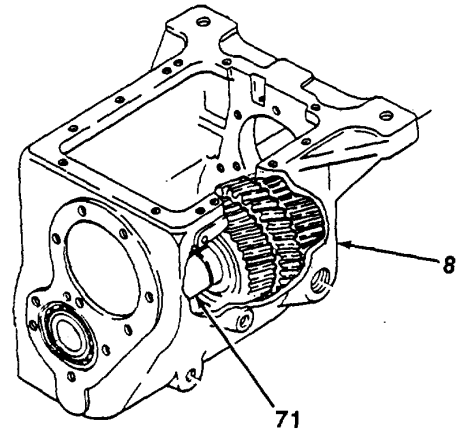

26. Install collar (52) to clutch teeth of gear (65) with extended hub of collar facing gear.
 27. Apply thin coat of grease to surface of mainshaft (49).
 28. Install mainshaft (49) through rear of case (8) and through gear (65).
 29. As mainshaft (49) is inserted in Case (8), install sleeve (62) and gear (61) to mainshaft.

NOTE

Ensure that Inner and outer races of bearing in rear of drive gearshaft remain in place.

30. As mainshaft (49) is advanced, Install gear (57) to mainshaft with counterbore in gear facing front of case (8).
 31. Install collar (58) over gear (57) with extended hub of collar facing front of case (8).
 32. Position X in. (12.6 mm) thick aluminum or brass plate between drive gearshaft (33) and gear (57).

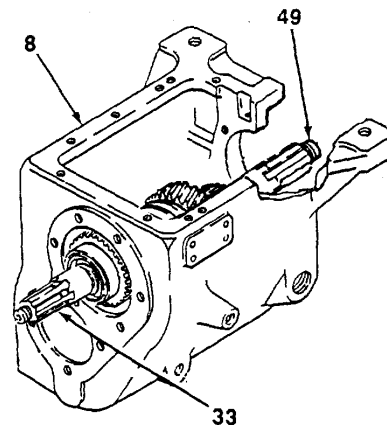

TA703751

6-2. AUXILIARY TRANSMISSION REPAIR (Con't).

33. Drive mainshaft (49) forward until retainer ring groove in mainshaft is exposed. Install new

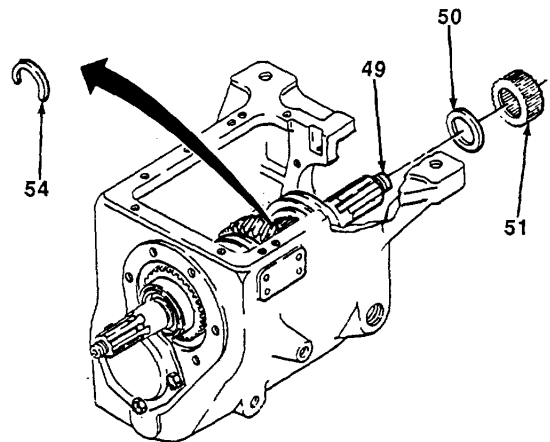

34. Install new thrustwasher (55) over rear of mainshaft (49) with flat surface of thrustwasher against gear.
 35. Install new ball bearing (56) over rear of mainshaft (49) with snapping of ball bearing facing away from case (8).
 36. Drive ball bearing (56) into case (8) until snapping is fully seated against case. Remove aluminum or brass plate.
 37. Install washer (50) and speedometer drive gear (51) to rear of mainshaft (49).
 38. Install bushing (48), gear (47), and flange (46) in bearing retainer (38) with two new lockwashers (45) and screws (44).

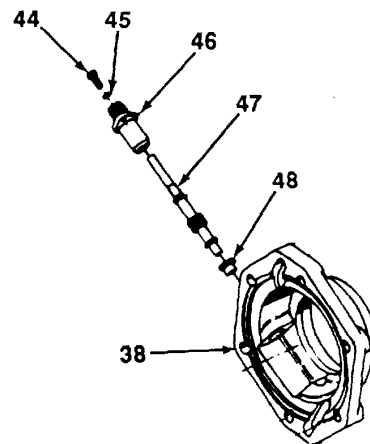
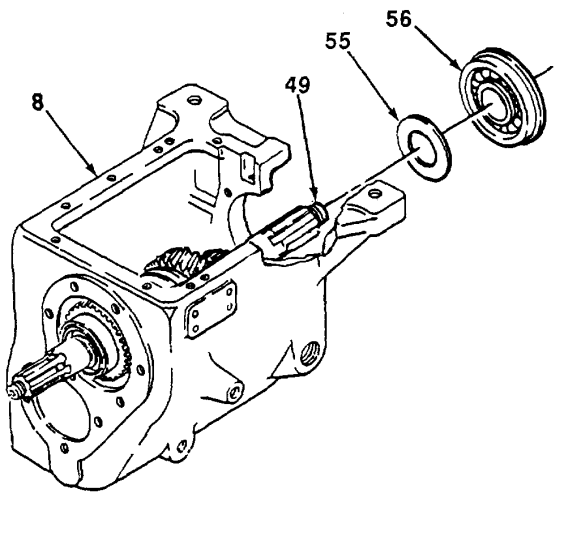

6-2. AUXILIARY TRANSMISSION REPAIR (Con't).

- 39. Apply sealant compound to outer diameter of new seal (41) and press seal into bearing retainer (38).
- 40. Apply thin coat of sealant compound to threads of two long screws (40), four screws (42), and both sides of new gasket (37).
- 41. Install gasket (37) and bearing retainer (38) to rear of case (8) with four new lockwashers (43) and screws (42).
- 42. Install two new lockwashers (39) and long screws (40). Torque screws (40 and 42) to 60-80 lb.-ft. (81 -108 N-m).

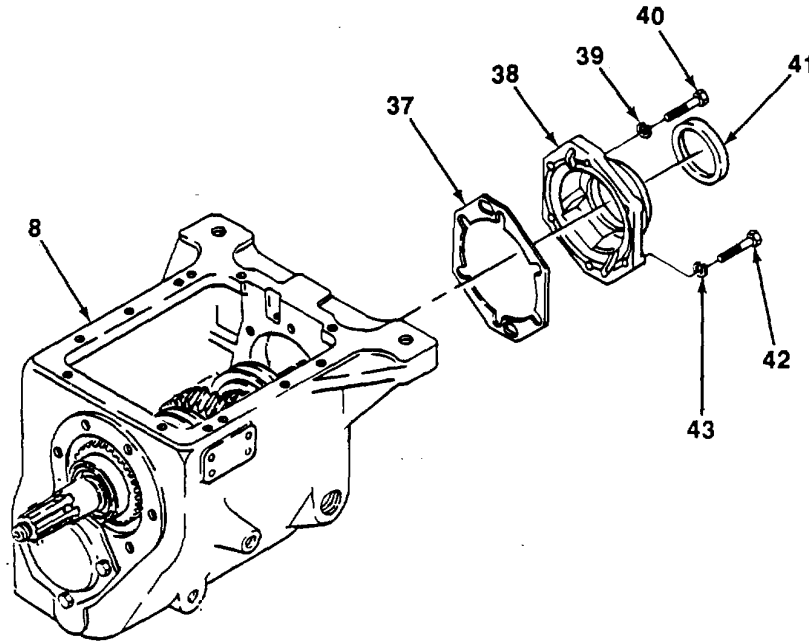

- 43. Install new bearing (36) to front of retainer (29) with flange of inner race facing upward.

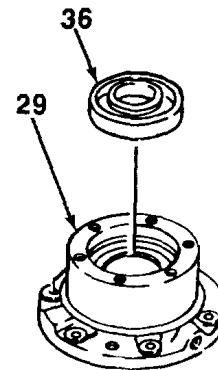

6-2. AUXILIARY TRANSMISSION REPAIR (C)

44. Install breather (31) in retainer (29).
45. Apply sealant compound to threads of six bolts (35) and both sides of new gasket (32).
46. Install gasket (32) and retainer (29) to front of case (8) with six new lockwashers (34) and bolts (35). Torque bolts to 60-80 lb.-ft. (81-108 N•m).

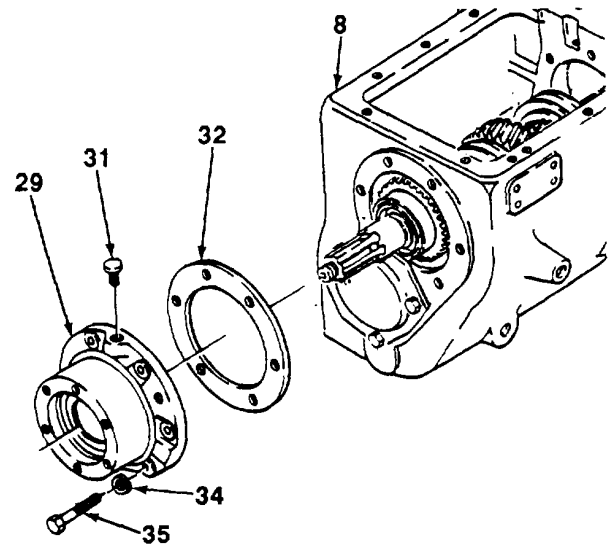

47. Press new seal (30) into bearing retainer (27).

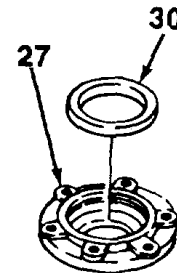

48. Apply thin coat of sealant compound to both sides of new gasket (28).
49. Install gasket (28) and bearing retainer (27) to retainer (29) with six new lockwashers (26) and bolts (25).
50. Loosely install washer (24) and nut (23) to each end of case (8).

NOTE

Perform steps 53 through 66 to assemble top cover housing.

51. Apply sealant compound to outer diameter of two new oil seals (13) and press oil seals into housing (6).
52. Install new spring (19), plunger (20), and ball (21).

TA703754

6-2. AUXILIARY TRANSMISSION REPAIR (Con't).

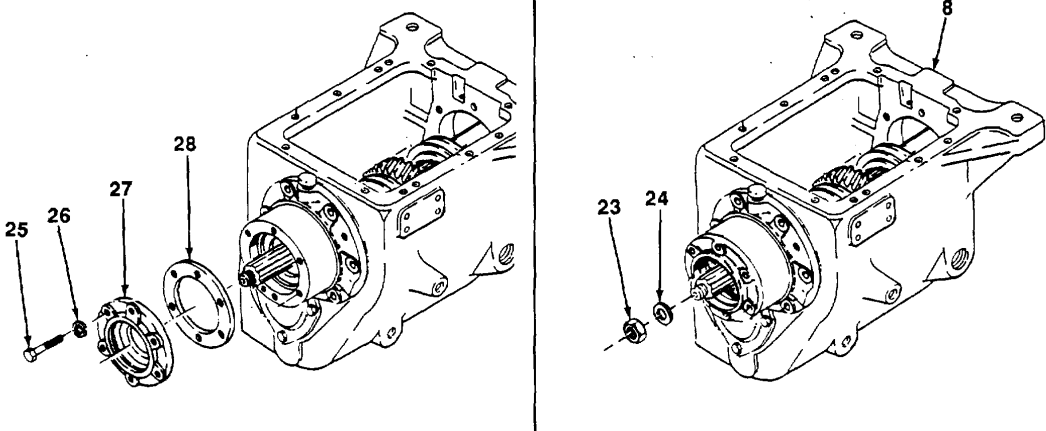

- 53. Apply thin coat of grease to surface of shift bar (3) and install shift bar with three notches facing ball (21).
- 54. Install shift fork (18) to shift bar (3) as shift bar is installed toward rear of housing (6). Ensure that long hub of shift fork faces rear of housing.
- 55. Install new screw (17) to shift fork (18). Torque screw to 40-50 lb.-ft. (54-68 N-m).

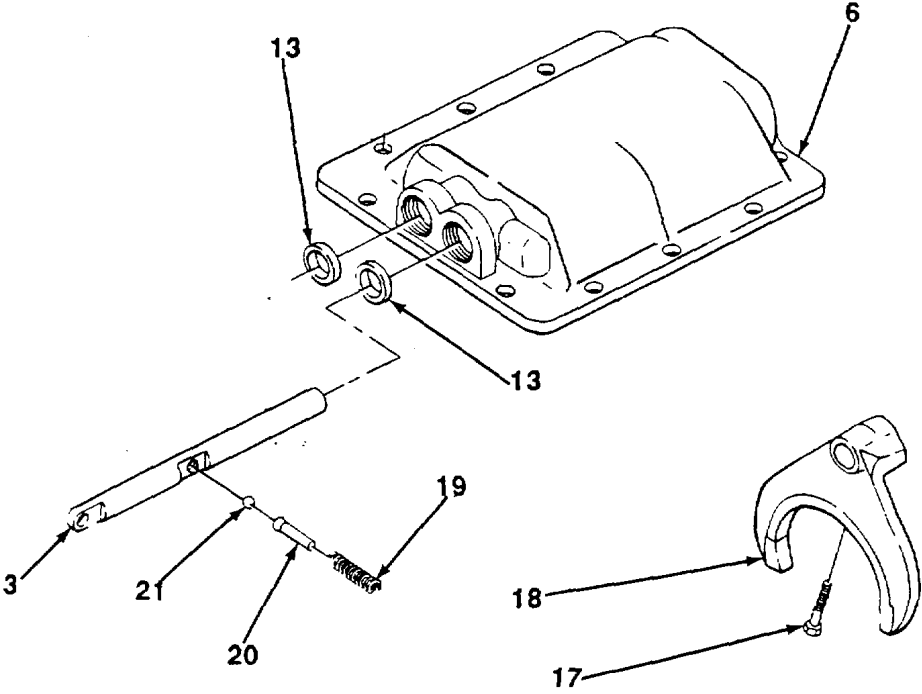

6-2. AUXILIARY TRANSMISSION REPAIR (Con't).

- 56. With shift bar (3) in neutral position, install new Interlock (22) into housing (6). Ensure that interlock seats in neutral notch of shift bar.
- 57. Apply thin coat of grease to surface of shaft (1) and install shaft with notches facing threaded hole in housing (6).
- 58. Install stop sleeve (14) and shift fork (15) to shaft (1) as shaft is installed toward rear of housing (6).
- 59. Install screw (16) to shift fork (15). Torque screw to 40-50 lb.-ft. (54-68 N-m).

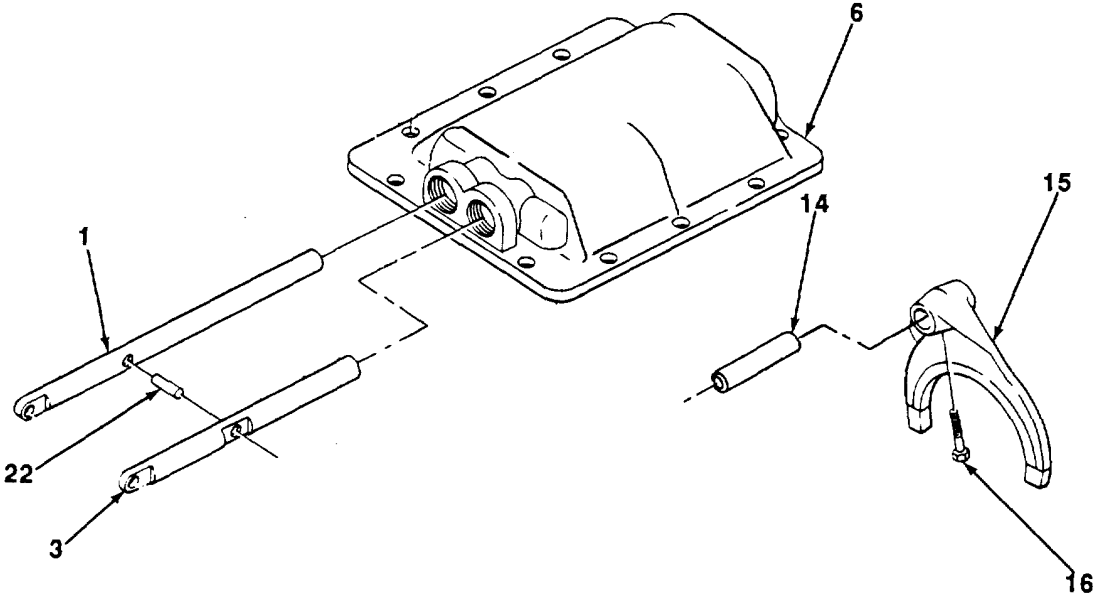

- 60. Install new ball (12), new plunger (11), new spring (10), and retainer (9) in housing (6).

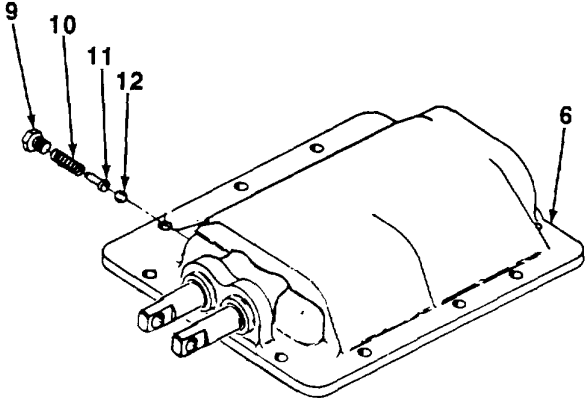

TA703756

6-2. AUXILIARY TRANSMISSION REPAIR (Con't).**NOTE**

Auxiliary transmission is in neutral when shaft and shift bar protrude evenly from case.

61. Position shaft (1) and shift bar (3) into neutral position.
62. Apply thin coat of sealant compound to both sides of new gasket (7).
63. Install gasket (7) and housing (6) to top of case (8). Ensure that shift forks mesh with collars.
64. Install ten new lockwashers (5) and bolts (4).

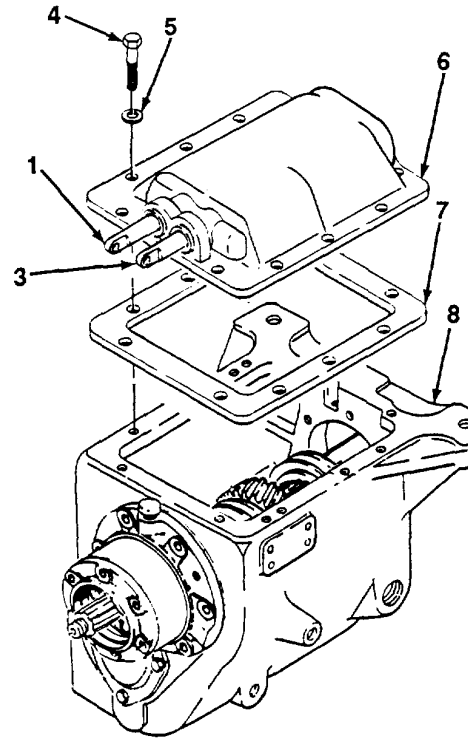
**FOLLOW-ON TASKS:**

- Install auxiliary transmission (see paragraph 6-1).

TA703757

6-3. AUXILIARY TRANSMISSION TOP COVER MAINTENANCE.

This Task Covers:

- | | |
|----------------------------|-----------------|
| a. Removal | d. Assembly |
| b. Disassembly | e. Installation |
| c. Cleaning and Inspection | |

Initial Setup:

Equipment Conditions:

- Auxiliary transmission linkage disconnected (see paragraph 6-4).

Tools/Test Equipment:

- General mechanic's tool kit
- Field automotive shop set

General Safety Instructions:

- Dry cleaning solvent is flammable and must not be used near open flame. Use only in a well-ventilated area.

Materials/Parts:

- Grease (Item 10, Appendix B)
- Sealant compound (Item 19, Appendix B)
- Dry cleaning solvent (Item 23, Appendix B)
- Three parts kits

a. REMOVAL**NOTE**

Auxiliary transmission is in neutral when shaft and shift bar protrude evenly from housing.

1. Using shaft (7) and shift bar (6), shift auxiliary transmission into neutral.
2. Remove ten bolts (1), washers (2), housing (3), and gasket (4) from top of case (5). Discard gasket.

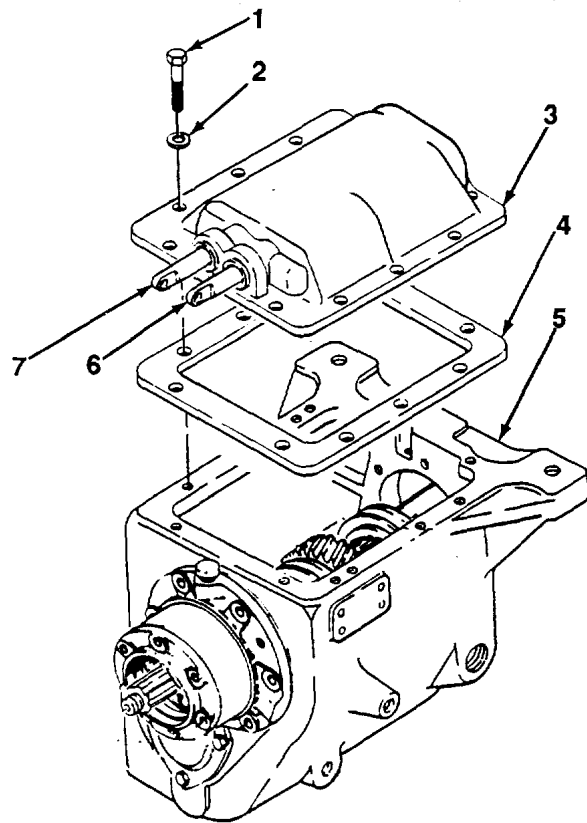

TA703758

6-3. AUXILIARY TRANSMISSION TOP COVER MAINTENANCE (Con't).

b. DISASSEMBLY

1. Remove retainer (8), spring (9), plunger (10), and ball (11) from housing (3). Discard spring, plunger, and ball.
2. Remove screw (15) from shift fork (14) and pull shaft (7) partially out of housing (3) to remove stop sleeve (13) and shift fork. Discard screw.
3. Remove screw (16) from shift fork (17). Discard screw.

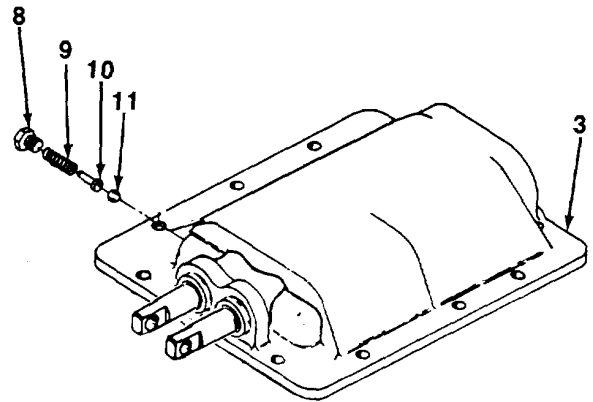

CAUTION

Interlock and ball will fall free as shaft is removed from housing. Do not lose or damage Interlock and ball.

4. Remove shaft (7), interlock (21), and ball (20) from housing (3). Discard interlock and ball.
5. Remove plunger (19) and spring (18) from housing (3). Discard plunger and spring.
6. Remove shift bar (6) and shift fork (17) from housing (3).
7. Remove two oil seals (12). Discard oil seals.

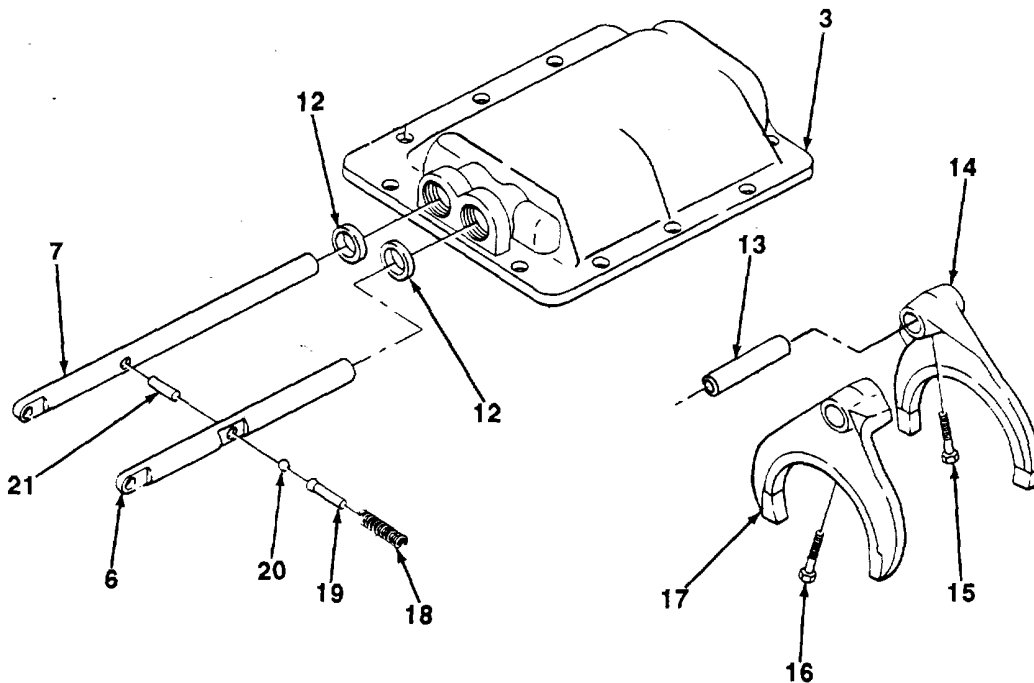

6-3. AUXILIARY TRANSMISSION TOP COVER MAINTENANCE (Con't).**c. CLEANING AND INSPECTION****WARNING**

Dry cleaning solvent, P-D-680, is toxic and flammable. Always wear protective goggles and gloves, and use only in a well-ventilated area. Avoid contact with skin, eyes, and clothes, and DO NOT breathe vapors. DO NOT use near open flame or excessive heat. The solvent's flash point is 100°F-138°F (38°C-59°C). If you become dizzy while using cleaning solvent, immediately get fresh air and medical help. If solvent contacts eyes, immediately wash your eyes and get medical aid.

1. Clean interior metal parts with dry cleaning solvent.
2. Clean exterior of housing with dry cleaning solvent or steam. Dry thoroughly.
3. Inspect metal parts for cracks, breaks, wear, and other damage. Replace if damaged.

d. ASSEMBLY

1. Apply sealant compound to outer diameter of two new oil seals (12) and press oil seals into housing (3).
2. Install new spring (18), new plunger (19), and new ball (20).
3. Apply thin coat of grease to surface of shift bar (6) and install shift bar with three notches facing ball (20).

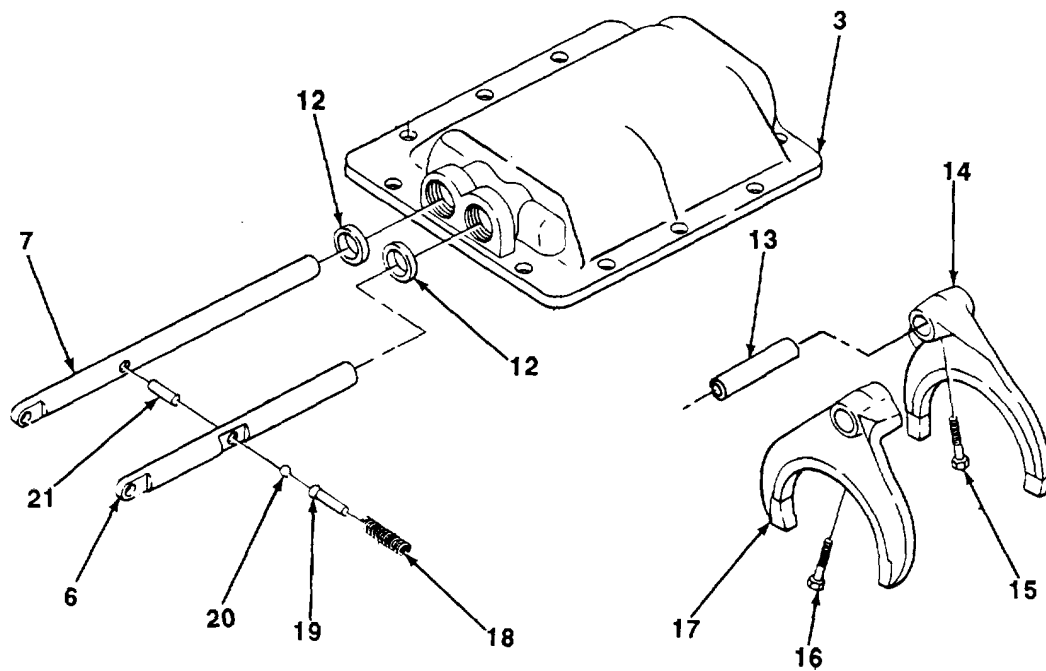

TA703760

6-3. AUXILIARY TRANSMISSION TOP COVER MAINTENANCE (Con't).

4. Install shift fork (17) to shift bar (6) as shift bar is installed toward rear of housing (3). Ensure that long hub of shift fork faces rear of housing.
5. Install new screw (16) to shift fork (17). Torque screw to 40-50 lb.-ft. (54-68 N.m).
6. With shift bar (6) in neutral position, install new interlock (21) into housing (3). Ensure that interlock seats in neutral notch of shift bar.
7. Apply thin coat of grease to surface of shaft (7) and install shaft with notches facing threaded hole in housing (3).
8. Install stop sleeve (13) and shift fork (14) to shaft (7) as shaft is installed toward rear of housing (3).
9. Install new screw (15) to shift fork (14). Torque screw to 40-50 lb.-ft. (54-68 N-m).
10. Install new ball (11), new plunger (10), new spring (9), and retainer (8) in housing (3).

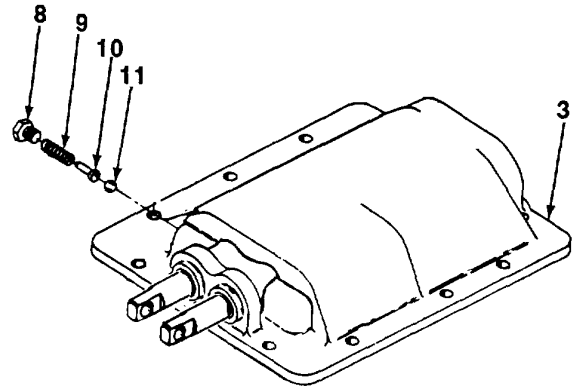

TA703761

6-3. AUXILIARY TRANSMISSION TOP COVER MAINTENANCE (Con't).

e. INSTALLATION

NOTE

Auxiliary transmission is In neutral when shaft and shift bar protrude evenly from housing.

- 1. Position shaft (7) and shift bar (6) into neutral position.
- 2. Apply thin coat of sealant compound to both sides of new gasket (4).
- 3. Install gasket (4) and housing (3) to top of case (5). Ensure that shift forks (14 and 17) mesh with collars.
- 4. Install ten washers (2) and bolts (1).

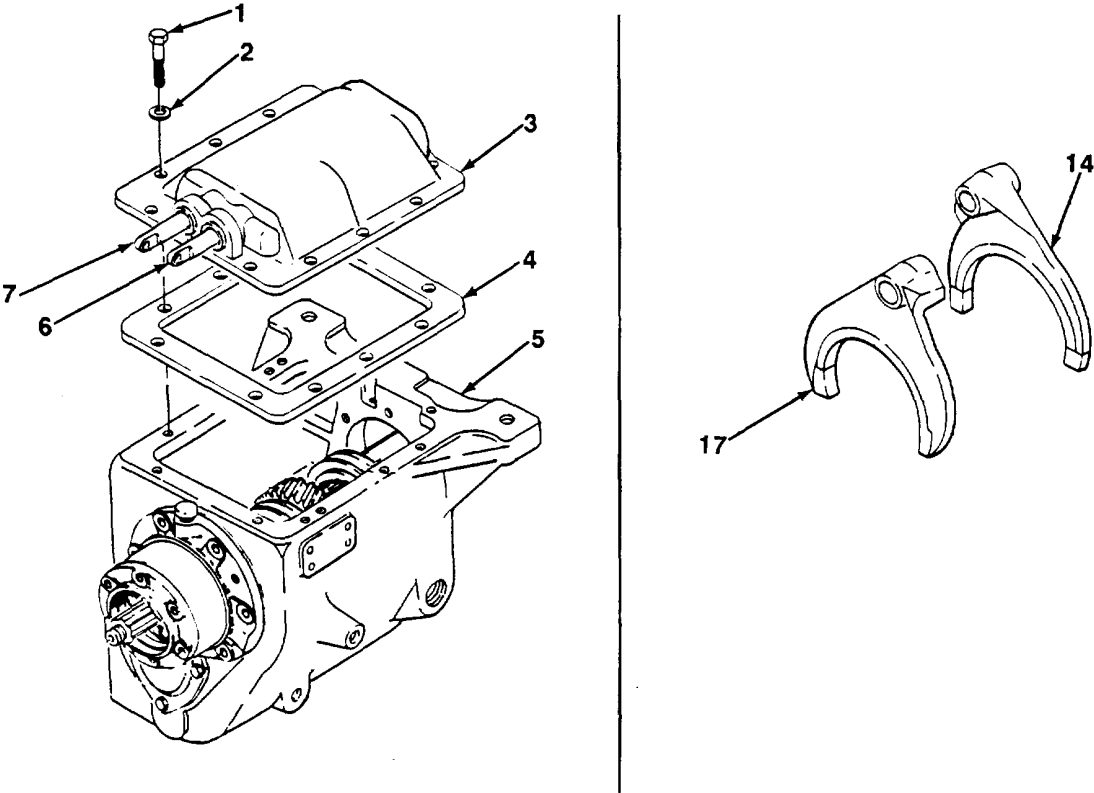

FOLLOW-ON TASKS:

- Connect auxiliary transmission linkage (see paragraph 6-4).

TA703762

6-4. AUXILIARY TRANSMISSION LINKAGE REPLACEMENT.

This Task Covers:

a. Removal

b. Installation

Initial Setup:

Equipment Conditions:

- Dump body raised (see TM 5-3805-254-10).
- Safety props and support blocks installed (see TM 5-3805-254-20).
- Shift lever handle removed (see TM 5-3805-254-20).

Materials/Parts:

- Grease (Item 10, Appendix B)
- One lockwasher
- Five cotter pins

Tools/Test Equipment:

* General mechanic's tool kit

a. REMOVAL

WARNING

Ensure that support blocks are used to support dump body weight. Failure to follow this warning may result in serious injury or death.

NOTE

- Both rods are removed in same manner.
- Note position of rods when removed to aid in installation.

6-4. AUXILIARY TRANSMISSION LINKAGE REPLACEMENT (Con't).

- 1. Remove cotter pin (9) and pin (1) from rod (2). Remove rod from bar (10). Discard cotter pin.
- 2. Remove cotter pin (8) and pin (4). Disconnect adjustable yoke (3) from shaft (5) and shift bar (7) of auxiliary transmission (6). Discard cotter pin.

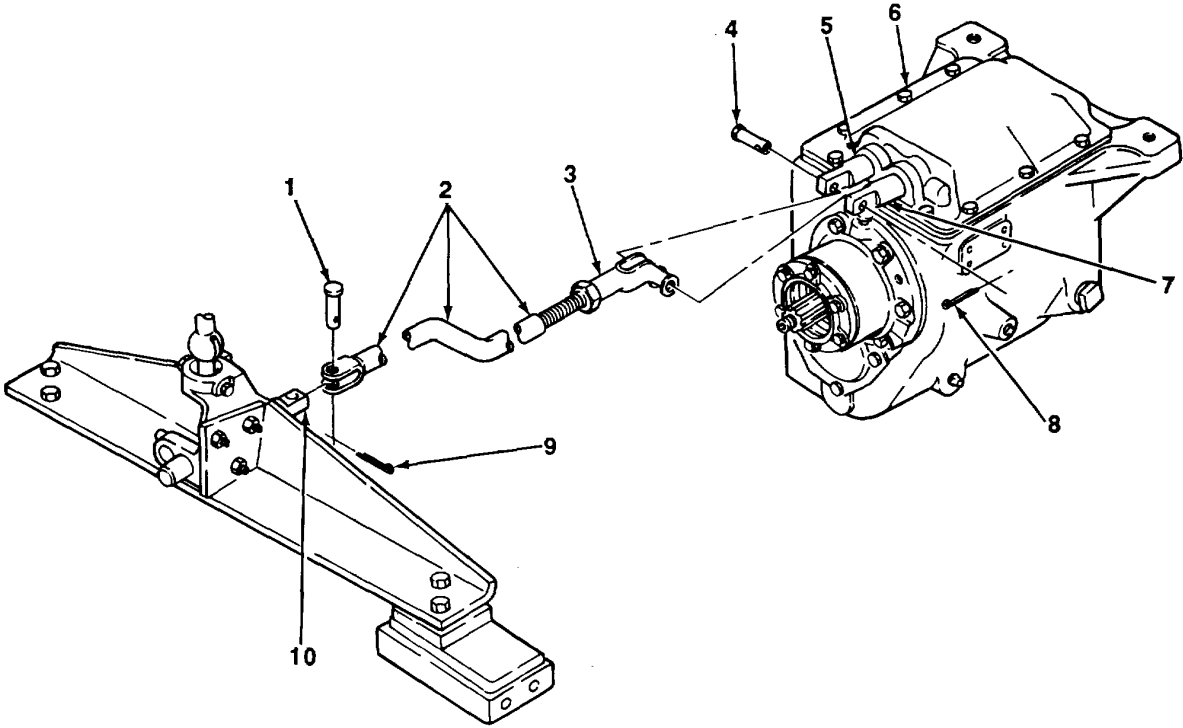

- 3. Mark location of nut (11) on rod (2) and remove adjustable yoke (3) and nut from rod.

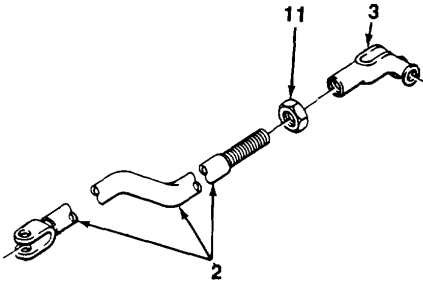

TA703763

TA703763

6-4. AUXILIARY TRANSMISSION LINKAGE REPLACEMENT (Con't).

4. Remove five nuts (15) and screws (12) from support (14) and control lever housing (13).
5. Remove control lever housing (13) from support (14).

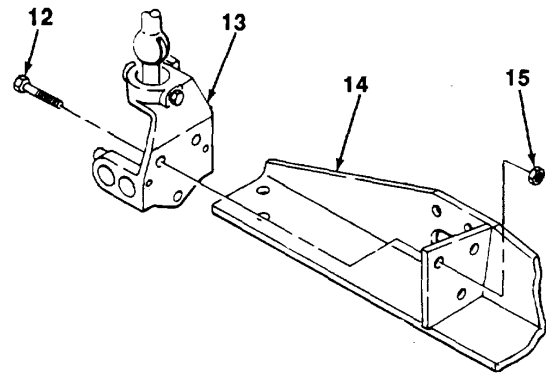

6. Remove cotter pin (19), washer (20), pivot spring (21), and washer (22) from control lever housing (13). Discard cotter pin.
7. Remove pivot screw (18), lockwasher (17), and shift lever (16) from control lever housing (13). Discard lockwasher.

NOTE

Note position of left and right bars in control lever housing to aid in installation.

8. Remove left and right bars (10).
9. Remove pin (23) from control lever housing (13).

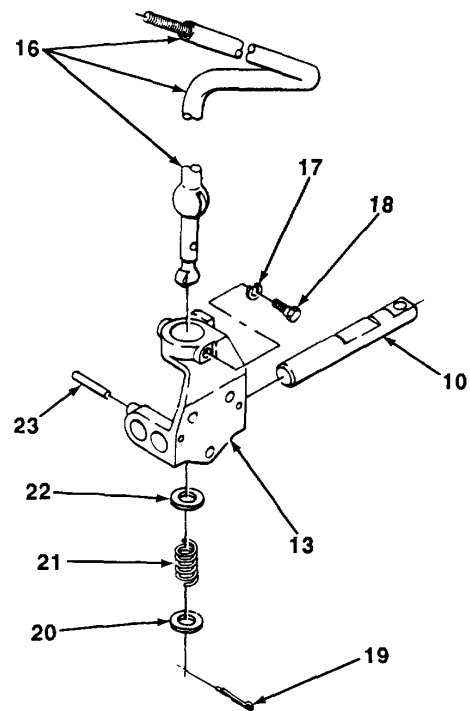

TA703764

6-4. AUXILIARY TRANSMISSION LINKAGE REPLACEMENT (Con't). 'r

10. Remove four nuts (29) and bolts (24). Remove support (14) from two brackets (25).
11. Remove four nuts (28), bolts (26), and two brackets (25) from left and right side of frame (27).

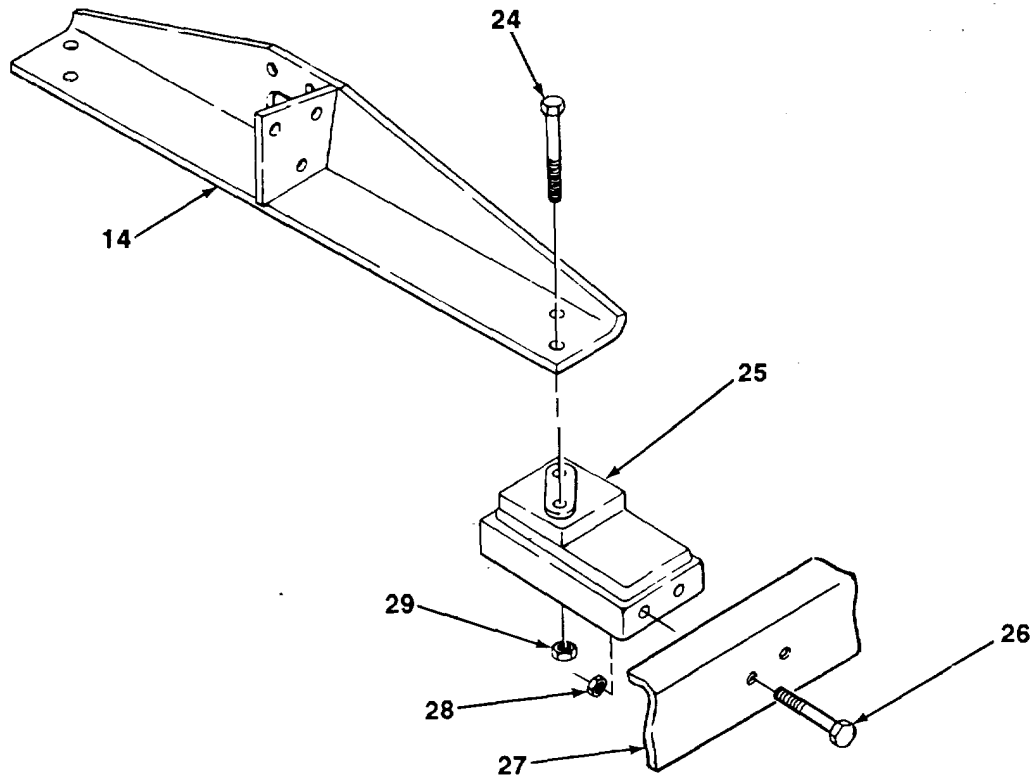
**b. INSTALLATION**

1. Install two brackets (25) to left and right side of frame (27) with four bolts (26) and nuts (28).
2. Install support (14) on two brackets (25) with four bolts (24) and nuts (29).

TA703765

6-4. AUXILIARY TRANSMISSION LINKAGE REPLACEMENT (Con't).

3. Install pin (23) in control lever housing (13).
4. Apply a thin coat of grease to surface of left and right bars (10) and install bars in control lever housing (13).
5. Install shift lever (16) in control lever housing (13) with new lockwasher (17) and pivot screw (18).
6. Install washer (22), pivot spring (21), and washer (20) in control lever housing (13) with new cotter pin (19).
7. Install control lever housing (13) on support (14) with five screws (12) and nuts (15).

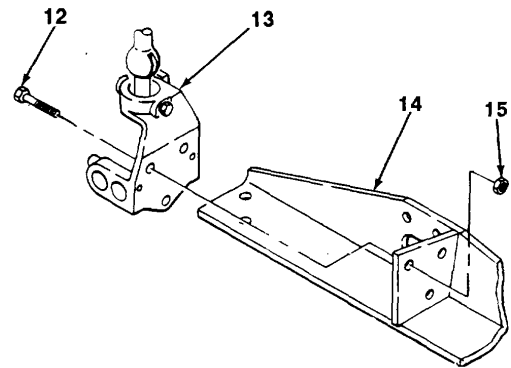
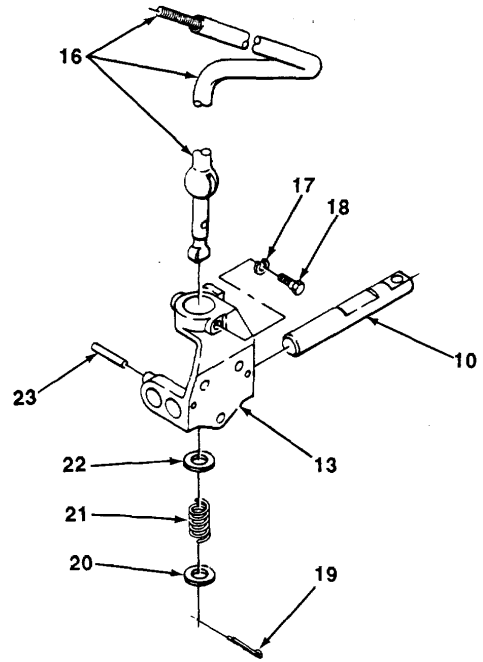

TA703766

6-4. AUXILIARY TRANSMISSION LINKAGE**NOTE**

Both rods are Installed In same manner.

8. Install nut (11) and adjustable yoke (3) on rod (2).
9. Install rod (2) on bar (10) with pin (1) and new cotter pin (9).
10. Connect adjustable yoke (3) to shaft (5) and shift bar (7) on auxiliary transmission (6). Install pin (4) and new cotter pin (8).
11. Tighten nut (11) against adjustable yoke (3).

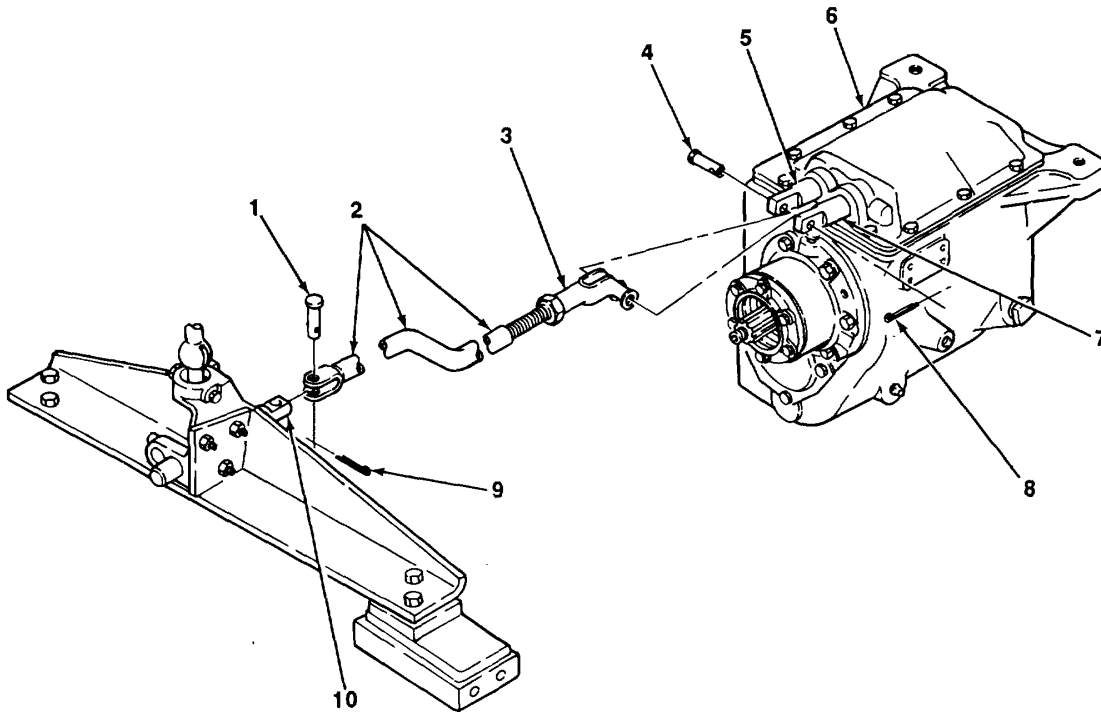
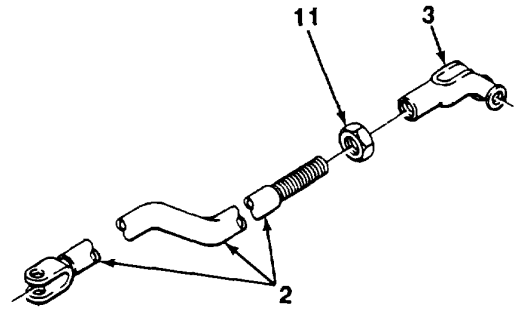
**FOLLOW-ON TASKS:**

- Install shift lever handle (see TM 5-3805-254-20).
- Remove support blocks and stow safety props (see TM 5-3805-254-20).
- Lower dump body (see TM 5-3805-254-10).

TA703767

6-5. TRANSMISSION COOLER HOSES AND FITTINGS REPLACEMENT.

This Task Covers:

a. Removal

b. Installation

Initial Setup:

Equipment Conditions:

- Transmission oil temperature switch removed (see TM 5-3805-254-20).
- Hydraulic fluid drained (see TM 5-3805-254-20).
- Floorboards and inserts removed (see paragraph 15-3).

Materials/Parts:

- Two plastic ties (Item 24, Appendix B)
- Two lockwashers
- Two performed packings

Tools/Test Equipment:

- General mechanic's tool kit

a. REMOVAL

1. Remove two plastic ties (4) from oil hoses (3 and 18). Discard plastic ties.
2. Remove two nuts (15), lockwashers (16), bolts (5), and four clamps (6) from two clip extensions (17). Discard lockwashers.

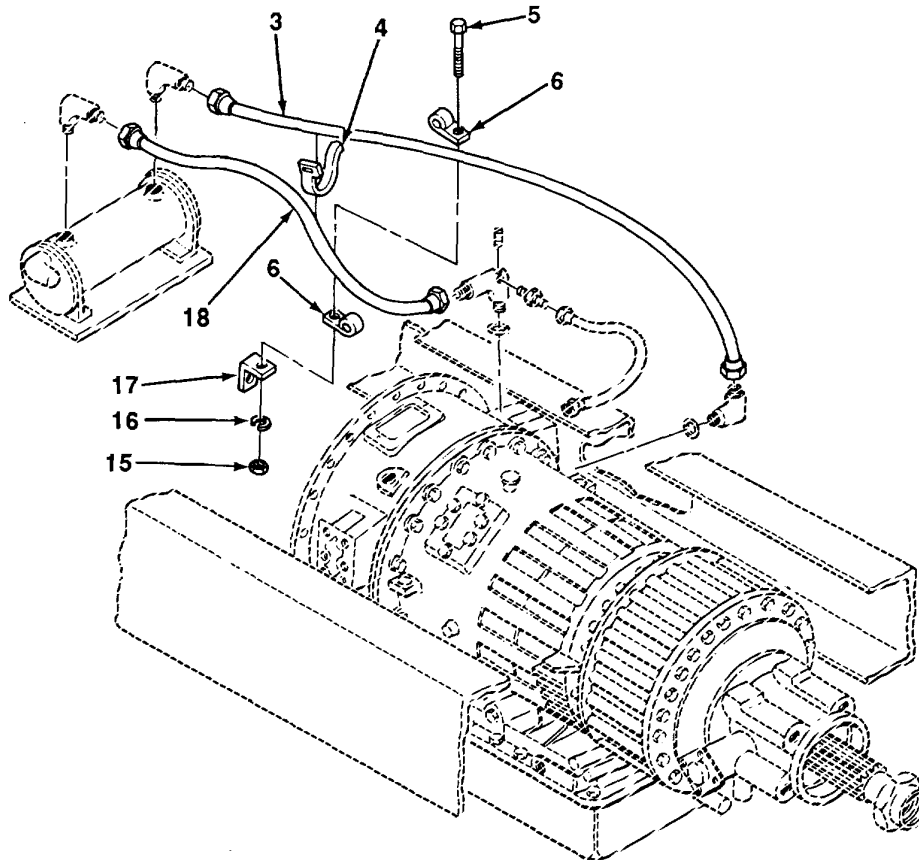

6-5. TRANSMISSION COOLER HOSES AND FITTINGS REPLACEMENT (Con't).

3. Remove four clamps (6) from oil hoses (3 and 18).
4. Disconnect oil hose (10) from adapter (9).
5. Remove oil hose (10) from power take-off.
6. Remove adapter (9) and nipple (7) from elbow (8).
7. Disconnect oil hose (3) from elbow (11).

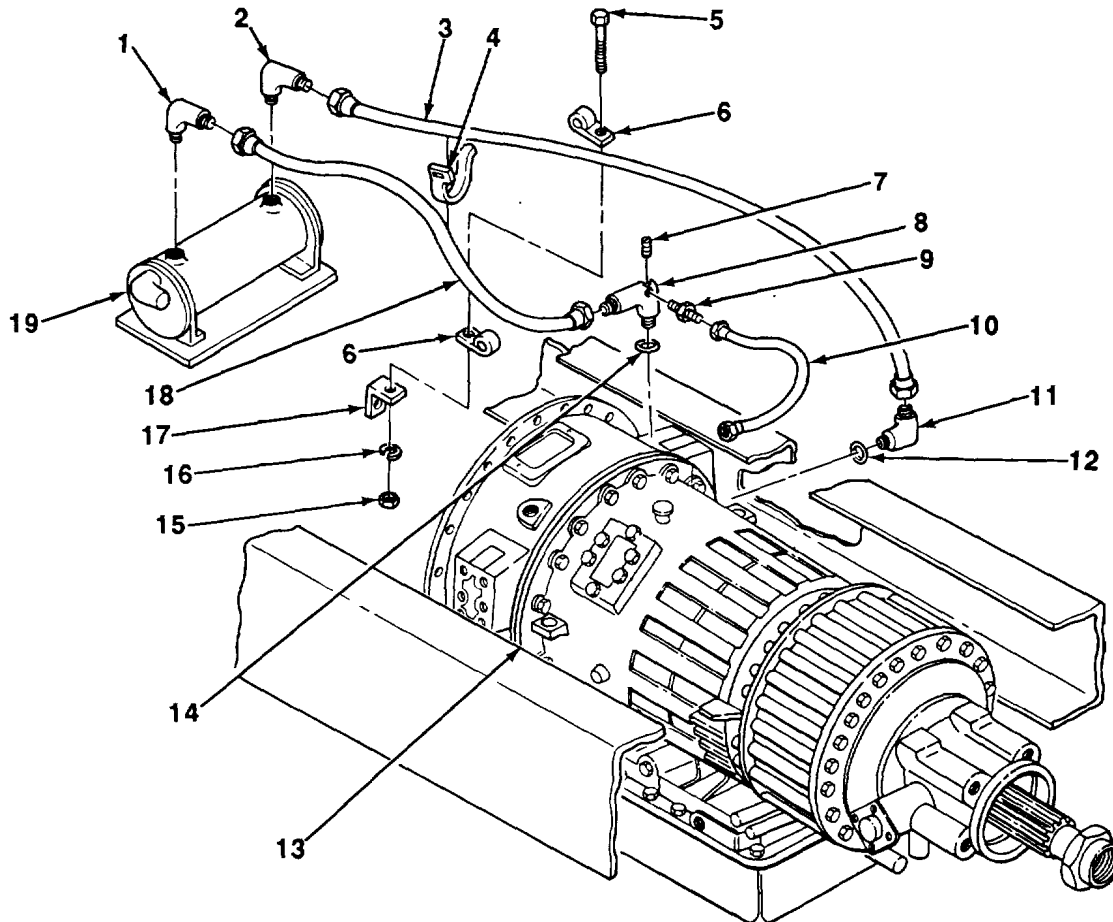

8. Remove elbow (11) and preformed packing (12) from transmission housing (13). Discard performed packing.
9. Remove oil hose (3) from elbow (2).
10. Remove elbow (2) from transmission oil cooler (19).
11. Disconnect oil hose (18) from elbow (1).
12. Remove elbow (1) from transmission oil cooler (19).
13. Remove oil hose (18) from elbow (8).
14. Remove elbow (8) and preformed packing (14) from side of transmission housing (13). Discard performed packing.

6-5. TRANSMISSION COOLER HOSES AND FITTINGS REPLACEMENT (Con't).

b. INSTALLATION

1. Install new preformed packing (14) and elbow (8) to side of transmission housing (13).
2. Connect oil hose (18) to elbow (8).
3. Install elbow (1) to transmission oil cooler (19).
4. Install oil hose (18) to elbow (1).
5. Install elbow (2) to transmission oil cooler (19).
6. Connect oil hose (3) to elbow (2).
7. Install new preformed packing (12) and elbow (11) to transmission housing (13).
8. Install oil hose (3) to elbow (11).
9. Install nipple (7) and adapter (9) to elbow (8).
10. Connect oil hose (10) to power take-off.
11. Install oil hose (10) to adapter (9).
12. Install four clamps (6) to hoses (3 and 18).
13. Install four clamps (6) to two clip extensions (17) with two bolts (5), new lockwashers (16), and nuts (15).
14. Install two new plastic ties (4) around oil hoses (3 and 18).

FOLLOW-ON TASKS:

- Install floorboards and inserts (see paragraph 15-3).
- Install transmission oil temperature switch (see TM 5-3805-254-20).
- Fill hydraulic fluid (see TM 5-3805-254-20).

6-6. TORQUE CONVERTER COOLER MAINTENANCE.

This Task Covers:

- | | |
|----------------------------|-----------------|
| a. Removal | d. Assembly |
| b. Disassembly | e. Installation |
| c. Cleaning and Inspection | |

Initial Setup:

Equipment Conditions:

- Hood removed (see TM 5-3805-254-20).
- Thermostat removed (see TM 5-3805-254-20).
- Radiator bypass coolant line removed (see TM 5-3805-254-20).
- Front water manifold hose removed (see TM 5-3805-254-20).

Tools/Test Equipment:

General Safety Instructions:

- Field automotive shop set

Materials/Parts:

- Sealant compound (Item 19, Appendix B)
- Dry cleaning solvent (Item 23, Appendix B)
- One gasket
- Seventeen lockwashers

Personnel Required: Two

• General mechanic's tool kit

- Dry cleaning solvent is flammable and must not be used near open flame. Use only in a well-ventilated area.

a. REMOVAL**WARNING**

Torque converter cooler is heavy. DO NOT remove nuts and screws unless auxiliary transmission is supported. Failure to follow this warning may result in injury or death to personnel.

1. Remove plug (3) and drain torque converter cooler (1).
2. Remove four nuts (5), lockwashers (4), screws (2), and torque converter cooler (1) from support (6). Discard lockwashers.

6-6. TORQUE CONVERTER COOLER MAINTENANCE (Con't).

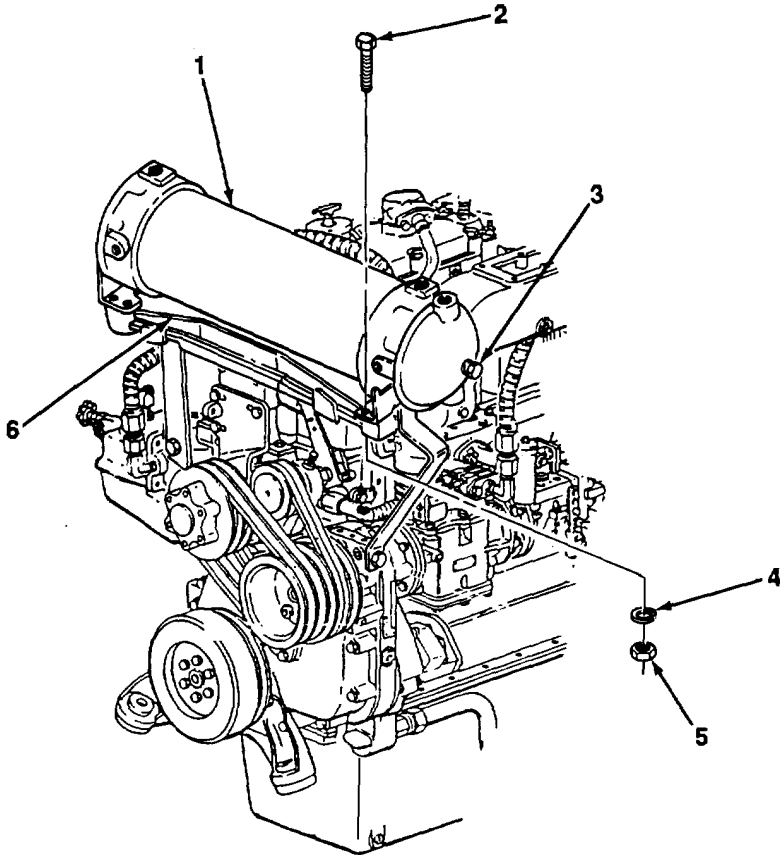

TA703770

6-6. TORQUE CONVERTER COOLER MAINTENANCE (Con't).

3. Remove two screws (14), lockwashers (13), and brace (7) from water pump housing (12). Discard lockwashers.
4. Remove two screws (9), lockwashers (10), and brace (8) from accessory drive housing (11). Discard lockwasher.

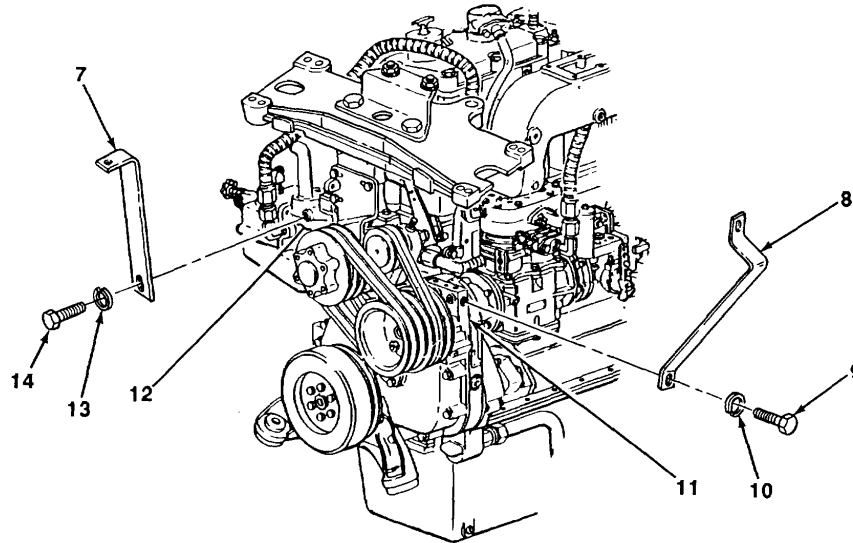

5. Remove three nuts (17), lockwashers (18), screws (15), and support (6) from bracket (16). Discard lockwashers.
6. Remove two nuts (19), lockwashers (20), and bracket (16) from engine (21). Discard lockwashers.

TA703771

6-6. TORQUE CONVERTER COOLER MAINTENANCE (Con't).

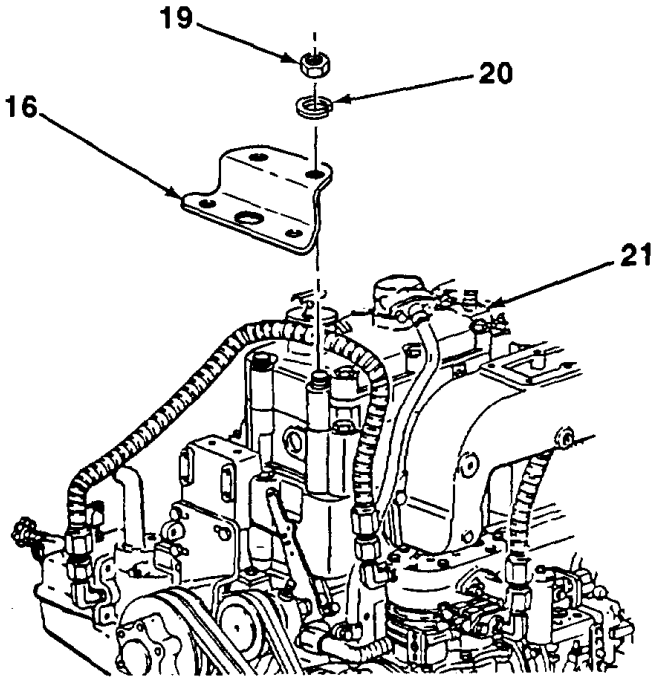
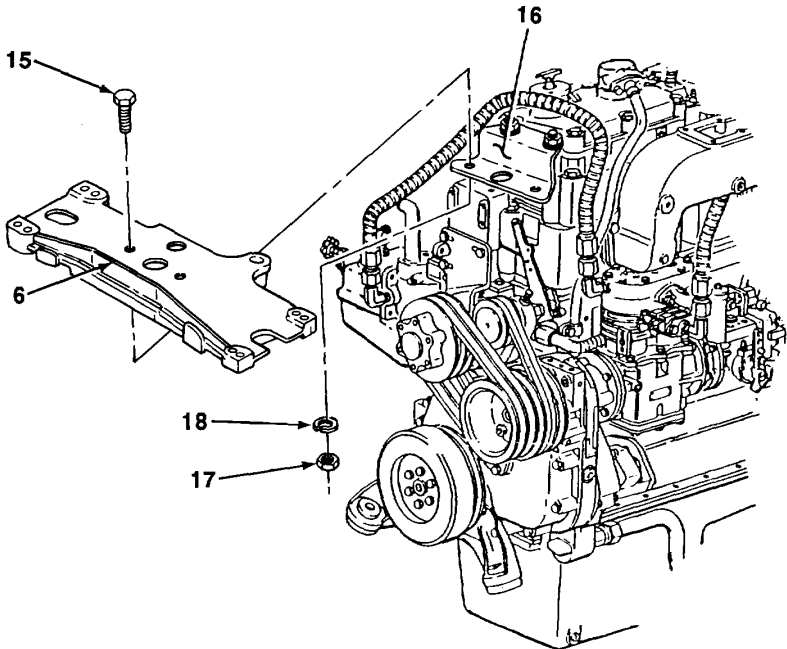

6-6. TORQUE CONVERTER COOLER MAINTENANCE (Con't).**b. DISASSEMBLY**

Remove four screws (22), lockwashers (23), bonnet (24), and gasket (25) from torque converter cooler (1). Discard lockwashers and gasket.

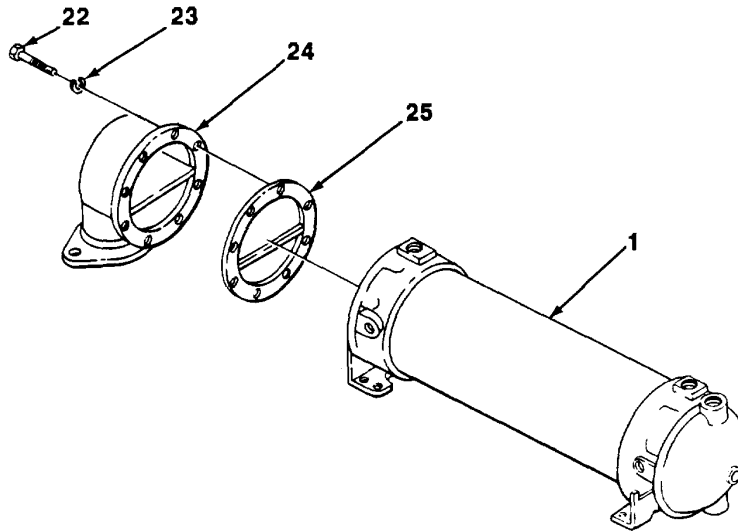
**c. CLEANING AND INSPECTION I****WARNING**

Dry cleaning solvent, P-D-680, is toxic and flammable. Always wear protective goggles and gloves, and use only in a well-ventilated area. Avoid contact with skin, eyes, and clothes, and DO NOT breathe vapors. DO NOT use near open flame or excessive heat. The solvent's flash point is 100°F-138°F (38°C-59°C). If you become dizzy while using cleaning solvent, immediately get fresh air and medical help. If solvent contacts eyes, immediately wash your eyes and get medical aid.

1. Clean metal parts with dry cleaning solvent.
2. Inspect metal parts for cracks, breaks, and other damage. Replace if damaged.

d. ASSEMBLY

1. Apply thin coat of sealant compound to both sides of new gasket (25).
2. Install gasket (25) and bonnet (24) to torque converter cooler (1) with four new lockwashers (23) and screws (22).

TA703773

6-6. TORQUE CONVERTER COOLER MAINTENANCE (Con't).

e. INSTALLATION**WARNING**

Torque converter cooler is heavy. DO NOT remove nuts and screws unless auxiliary transmission is supported. Failure to follow this warning may result in injury or death to personnel.

1. Install bracket (16) to top of engine (21) with two new lockwashers (20) and nuts (19). Torque nuts to 55-60 lb.-ft. (75-81 N•m).

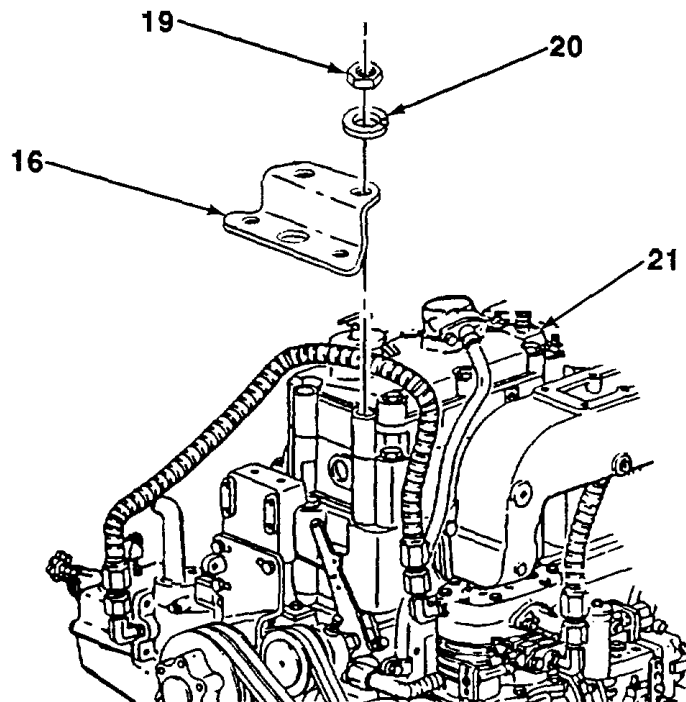

TA703774

6-6. TORQUE CONVERTER COOLER MAINTENANCE (Con't).

- 2. Install support (6) and bracket (16) with three screws (15), new lockwashers (18), and nuts (17).

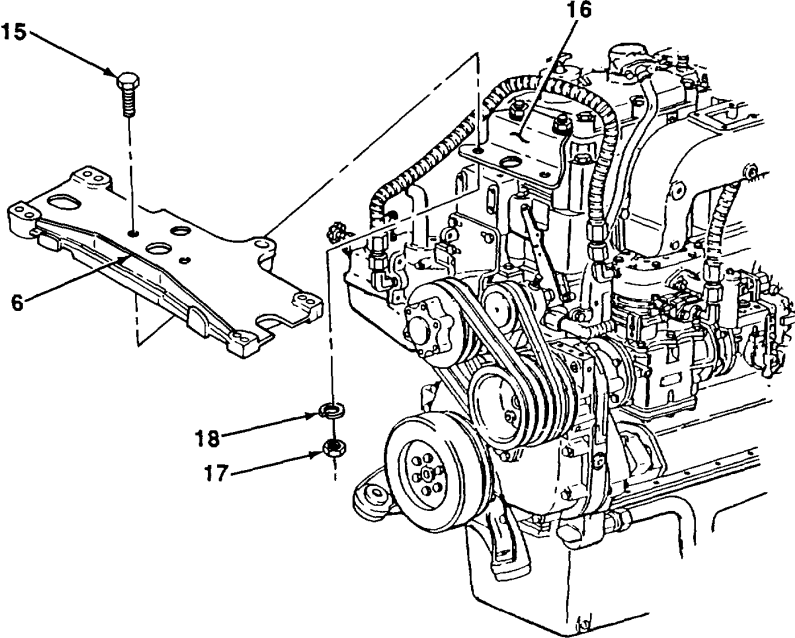

TA7033775

6-6. TORQUE CONVERTER COOLER MAINTENANCE (Con't).

3. Install brace (8) on accessory drive housing (11) with two new lockwashers (10) and screws (9).
4. Install brace (7) on water pump housing (12) with two new lockwashers (13) and screws (14).

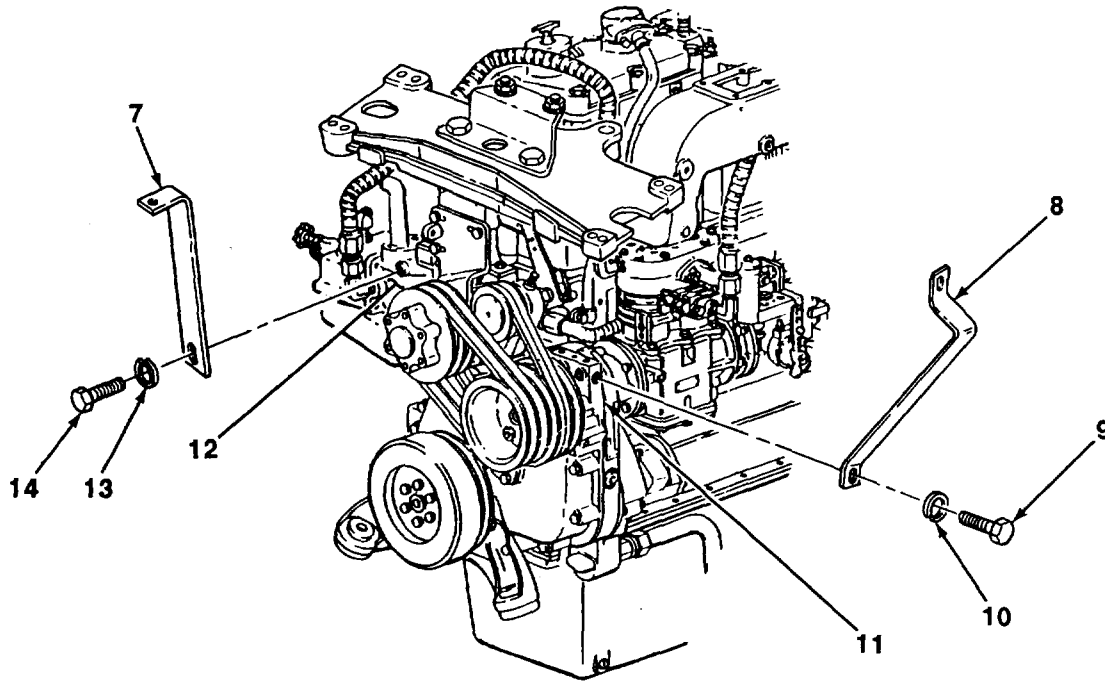

TA703776

6-6. TORQUE CONVERTER COOLER MAINTENANCE (Con't).

5. Install torque converter cooler (1) to support (6) with four screws (2), new lockwashers (4), and nuts (5).
- 6 .Install plug (3) into torque converter cooler (1).

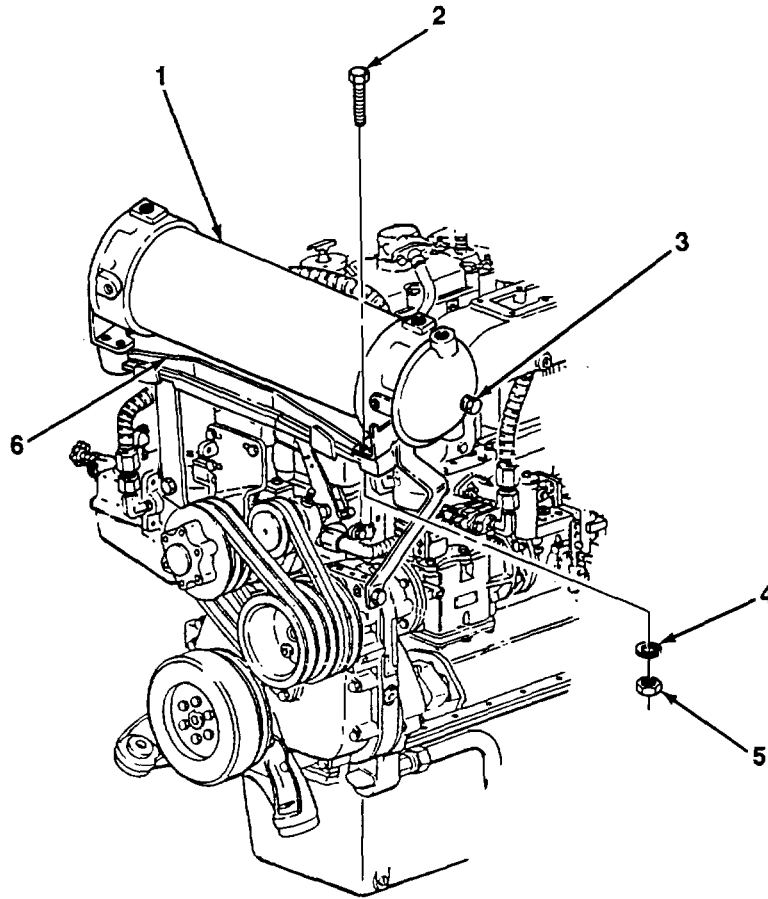
**FOLLOW-ON TASKS:**

- Install front water manifold hose (see TM 5-3805-254-20).
- Install radiator bypass coolant line (see TM 5-3805-254-20).
- Install thermostat (see TM 5-3805-254-20).
- Install hood (see TM 5-3805-254-20).
- Fill transmission as necessary (see TM 5-3805-254-20).

6-7. TRANSMISSION MODULATOR VA

This Task Covers:

- | | |
|----------------------------|-----------------|
| a. Removal | d. Assembly |
| b. Disassembly | e. Installation |
| c. Cleaning and Inspection | |

Initial Setup:

Materials/Parts:

- Detergent (Item 6, Appendix B)
- Hydraulic fluid (Item 7, Appendix B)
- Dry cleaning solvent (Item 23, Appendix B)
- One cotter pin
- One gasket
- Three preformed packings
- Nine lockwashers

Tools/Test equipment

- General mechanics tool kit

General Safety Instructions

- Dry cleaning solvent is flammable and must not be used near open flame. Use only in a well-ventilated area.
-

6-7. TRANSMISSION MODULATOR VALVE MAINTENANCE (Con't).

a. REMOVAL

1. Remove cotter pin (7) and washer (8), and disconnect cable extension (9) from throttle lever (1). Discard cotter pin.
2. Remove two screws (6), lockwashers (5), and mounting bracket (3). Discard lockwashers.
3. Disconnect sprint (2) from cable extension (9) and angle (4).

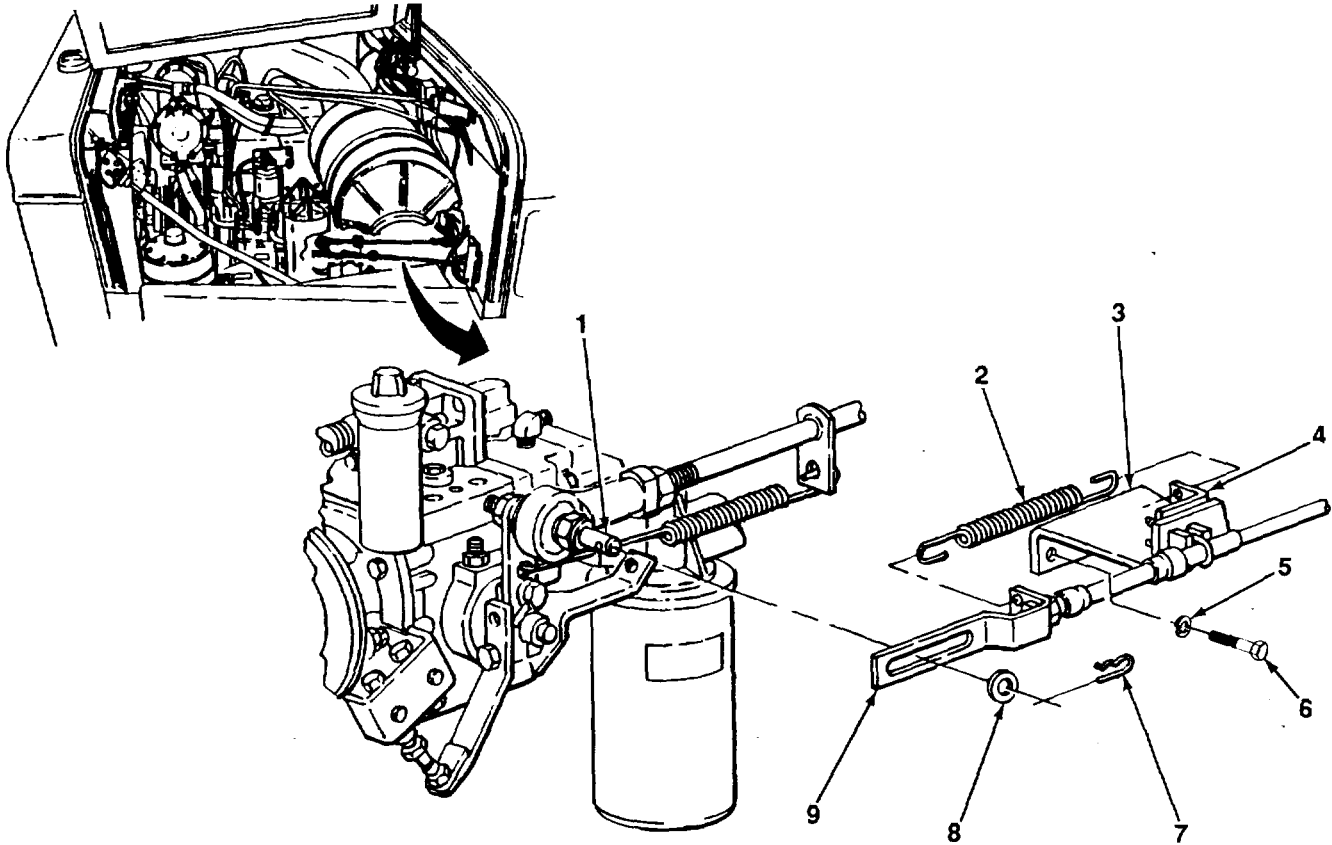

4. Remove two nuts (10), lockwashers (11), U-bolt (13), spacer (12), and angle (4) from mounting bracket (3) and modulator valve cable (14). Discard lockwashers.

TA703778

6-7. TRANSMISSION MODULATOR VALVE MAINTENANCE (Con't).

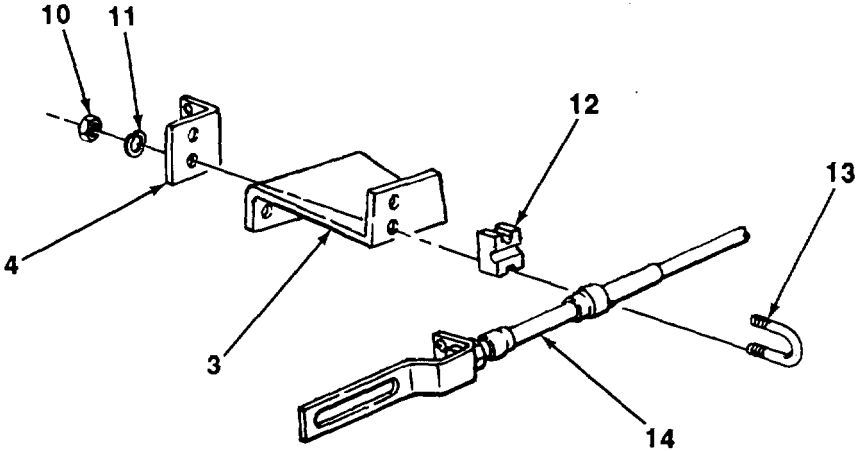

- 5. Remove screw (18), strap (15), modulator valve (19), and preformed packing (16) from left side of transmission (17). Discard preformed packing.
- 6. Measure or mark position of cable extension (9) in relation to end of modulator valve cable (14) for assembly.
- 7. Remove two nuts (20) and cable extension (9) from end of modulator valve cable (14).

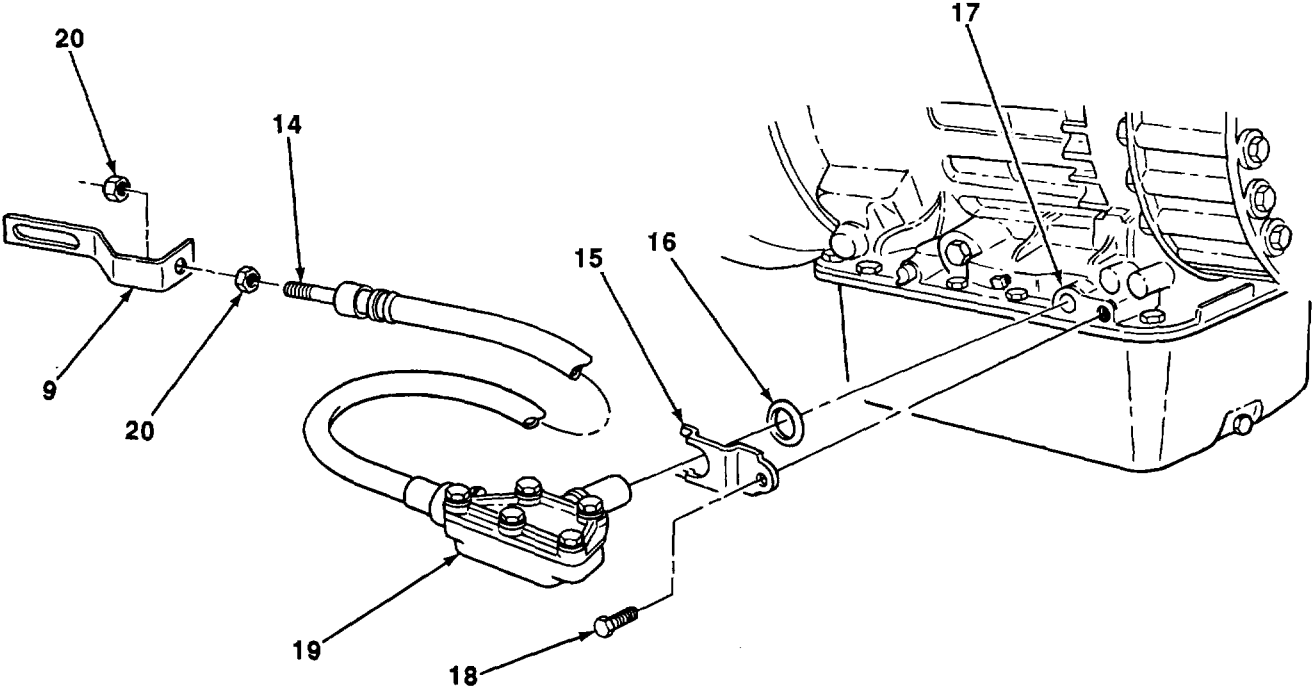

TA703779

6-7. TRANSMISSION MODULATOR VALVE MAINTENANCE (Con't).

b. DISASSEMBLY

1. Remove five screws (21), lockwashers (22), and cover (23) from housing (25). Discard lockwashers.
2. Remove gasket (24) from housing (25). Discard gasket.

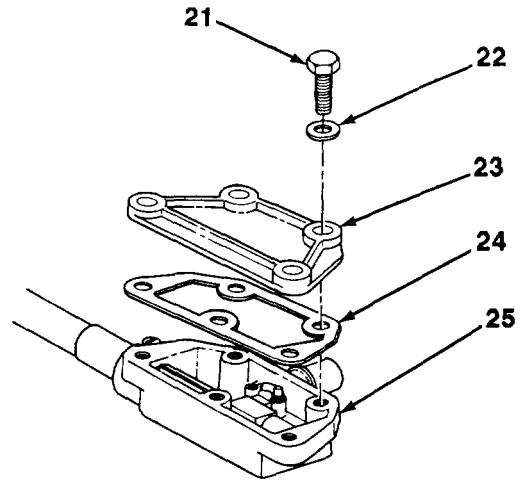

3. Remove pin (29) to disconnect cam (30) from housing (25).
4. Lift plastic yoke (28) upward from housing (25) and remove plastic yoke, cam (30), spring retainer (32), and spring (31) from end of modulator valve cable (14).
5. Remove screw (27) and housing (25) from end of modulator valve cable (14).
6. Remove preformed packing (26) from modulator valve cable (14). Discard preformed packing.

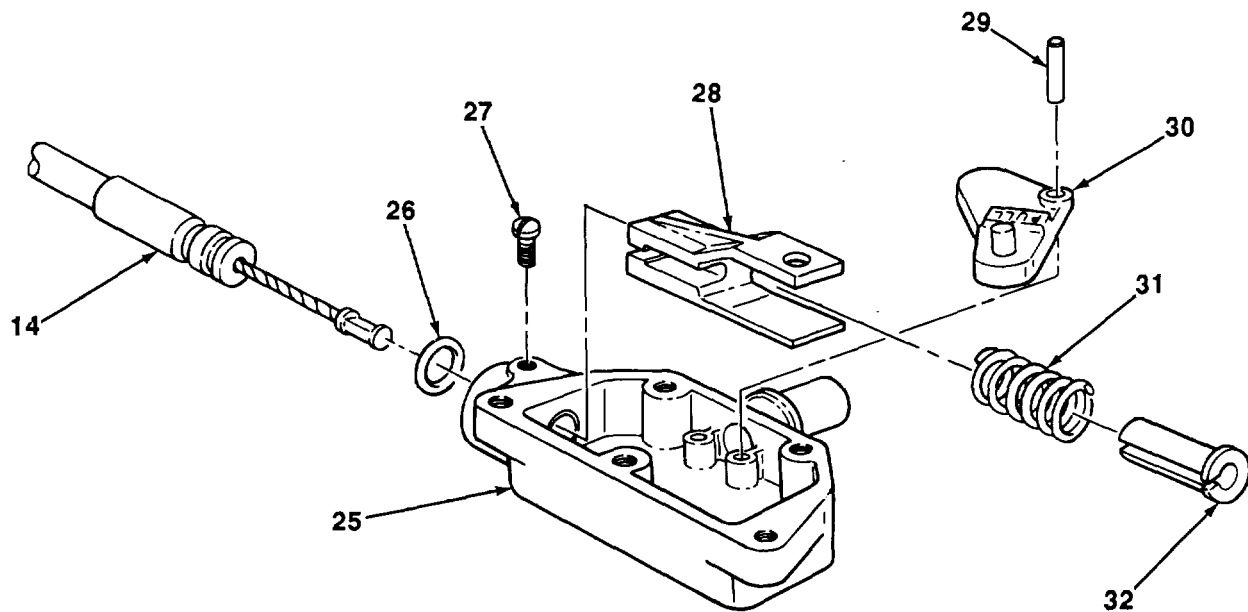

TA703780

6-7. TRANSMISSION MODULATOR VALVE MAINTENANCE (Con't).

c. CLEANING AND INSPECTION

WARNING

Dry cleaning solvent, P-D-680, is toxic and flammable. Always wear protective goggles and gloves, and use only in a well-ventilated area. Avoid contact with skin, eyes, and clothes, and DO NOT breathe vapors. DO NOT use near open flame or excessive heat. The solvent's flash point is 100°F-138°F (38°C-59°C). If you become dizzy while using cleaning solvent, immediately get fresh air and medical help. If solvent contacts eyes, immediately wash your eyes and get medical aid.

1. Clean metal parts with dry cleaning solvent.
2. Inspect metal parts for cracks, breaks, wear, or other damage. Replace if damaged.
3. Clean plastic housing of modulator valve cable with detergent and water solution.
4. Inspect plastic housing for cuts, wear, or other damage. Replace modulator valve cable assembly if damaged.
5. Inspect center cable of modulator valve cable assembly for wear or other damage. Replace modulator valve cable assembly if damaged.
6. Apply thin coat of hydraulic fluid to all metal internal parts of modulator valve and center cable of modulator valve cable assembly.

d. ASSEMBLY

1. Install new preformed packing (26) to end of modulator valve cable (14).
2. Install modulator valve cable (14) to housing (25) with screw (27).
3. Install spring (31), spring retainer (32), cam (30), and plastic yoke (28) to modulator valve cable (14).
4. Connect cam (30) to housing (25) with pin (29).
5. Position new gasket (24) to housing (25).
6. Install cover (23) with five new lockwashers (22) and screws (21).

6-7. TRANSMISSION MODULATOR VALVE MAINTENANCE (Con't).

e. INSTALLATION

- 1. Loosely install two nuts (20) and cable extension (9) to end of modulator valve cable (14).
- 2. Install new preformed packing (16) and modulator valve (19) to left side of transmission (17) with strap (15) and screw (1 R).

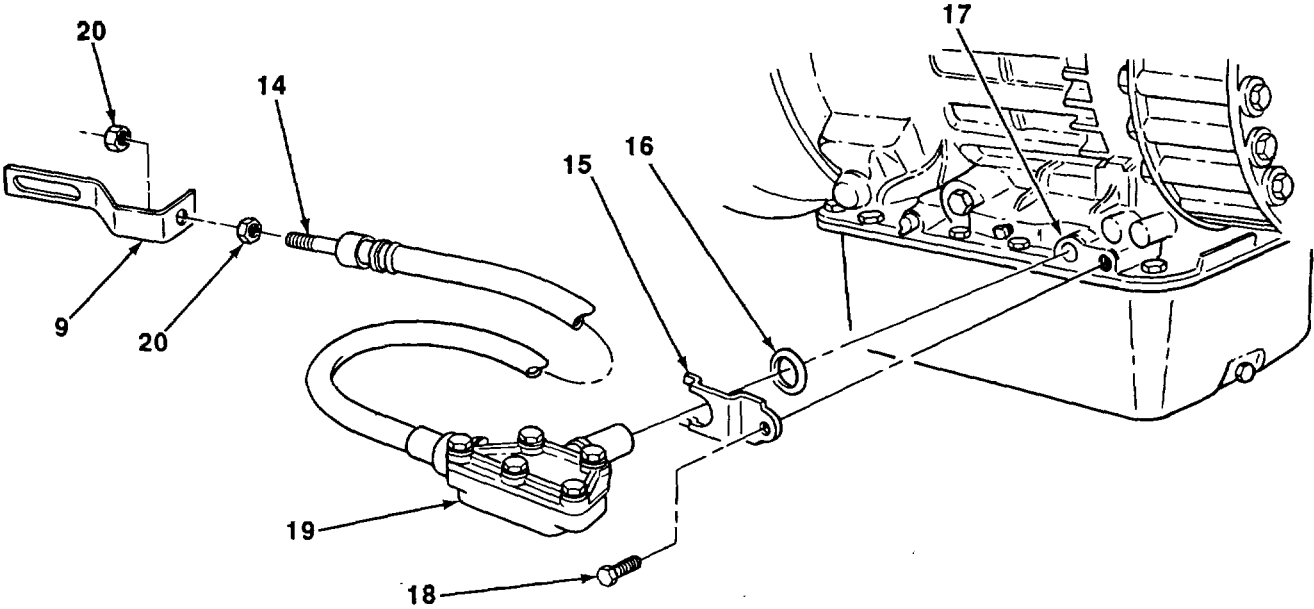

- 3. Install spacer (12), U-bolt (13), mounting bracket (3), and angle (4) to modulator valve cable (14) with two new lockwashers (11) and nuts (10).

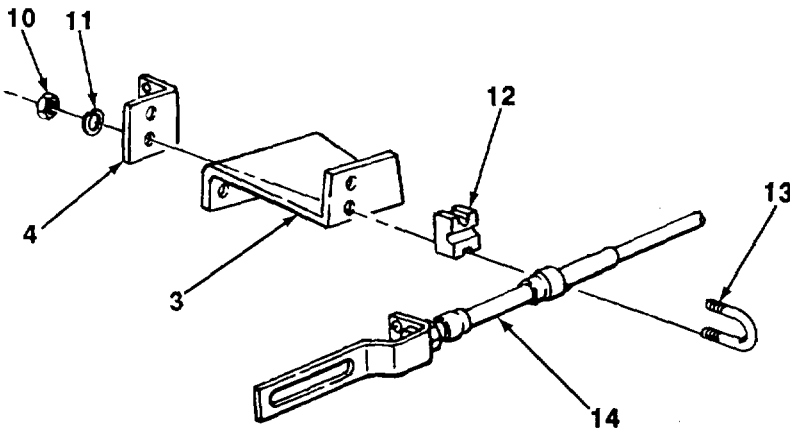

TA703781

6-7. TRANSMISSION MODULATOR VALVE MAINTENANCE (Con't).

4. Connect spring (2) to angle (4) and cable extension (9).
5. Install mounting bracket (3) with two new lockwashers (5) and screws (6).
6. Connect cable extension (9) to throttle lever (1) with washer (8) and new cotter pin (7).

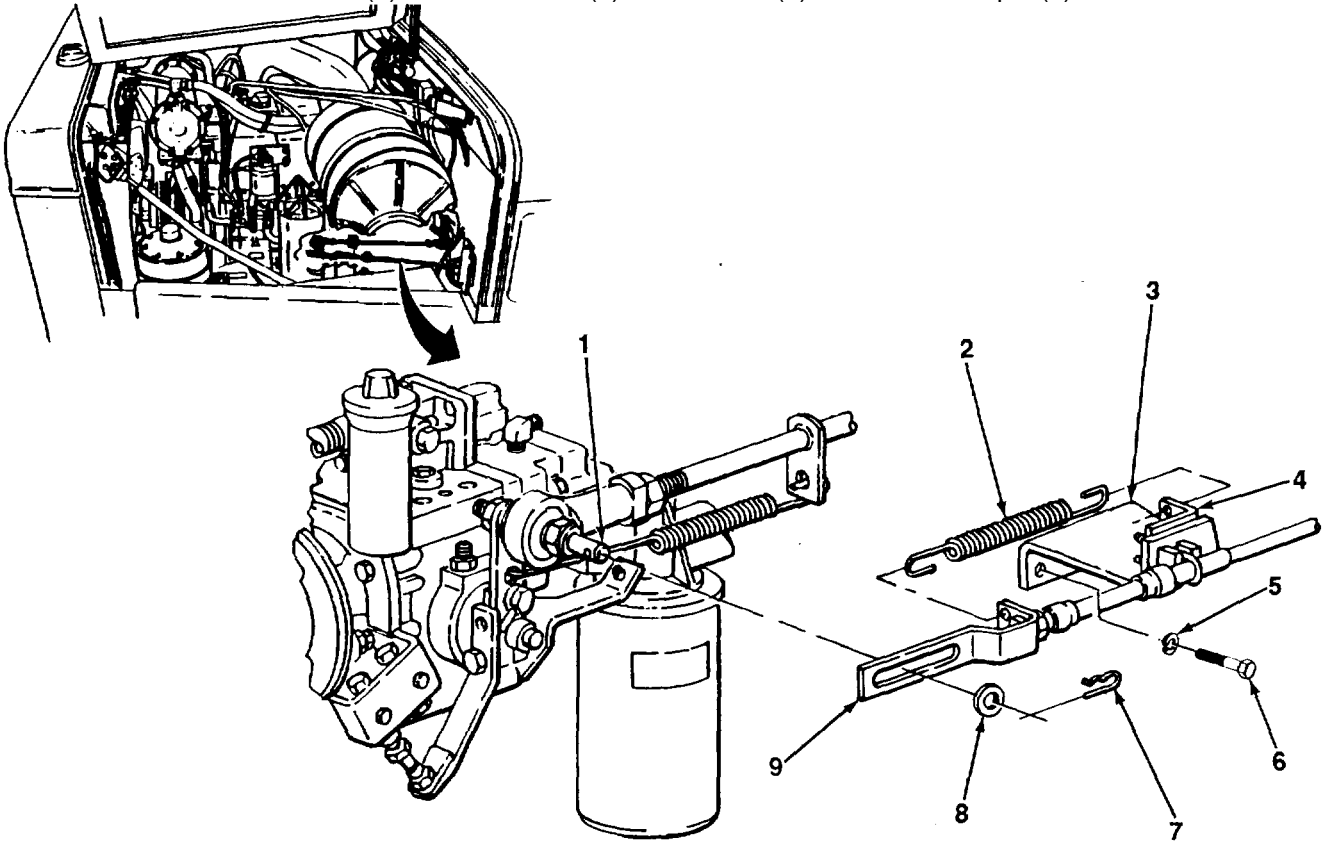

7. Tighten two nuts (20) against cable extension (9).

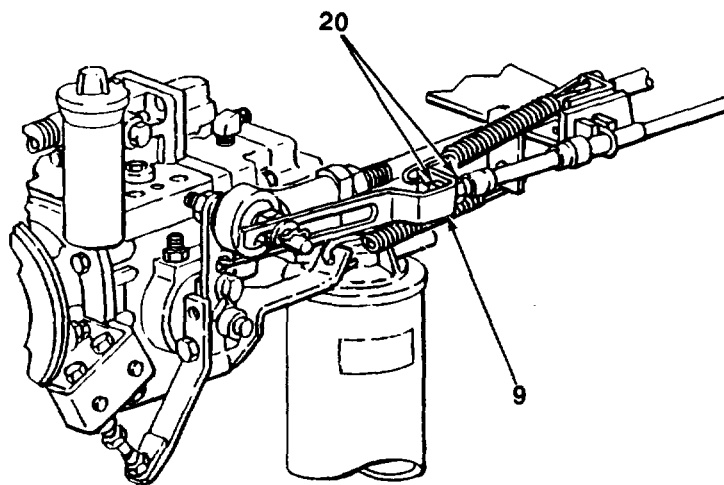

6-8. TRANSMISSION REPLACEMENT.

This Task Covers:

a. Removal

b. Installation

Initial Setup:

Equipment Conditions:

- Hydraulic fluid drained (see TM 5-3805-254-20).
- Floorboards and inserts removed (see paragraph 15-3).
- Transmission oil pressure gage line and fittings removed (see TM 5-3805-254-20).
- Power take-off removed (see paragraph 16-1).
- Transmission cooler hoses disconnected (see paragraph 6-5).
- Transmission modulator valve removed (see paragraph 6-7).
- Exhaust pipe removed (TM 5-3805-254-20).
- Transmission oil filler tube and dipstick removed (see TM 5-3805-254-20).
- Transmission shift cable disconnected (see TM 5-3805-254-20).

Equipment Conditions (Con't):

- Transmission to auxiliary transmission propeller shaft removed (see paragraph 7-1).
- Frame tie tube removed (see paragraph 14-3).
- Transmission wiring harness leads tagged and disconnected (see paragraph 5-6).

Materials/Parts:

- Marker tags (Item 25, Appendix B)
- Four lockwashers

Tools/Test Equipment:

- General mechanic's tool kit
- Field automotive shop set

Personnel Required: Two**a. REMOVAL**

1. Remove two screws (4), lockwashers (3), and housing cover (2) from right side of engine flywheel housing (18). Discard lockwashers.

CAUTION**Rotate engine only in normal operating direction to prevent damage to engine.****NOTE****Normal rotation of engine is clockwise when facing front of engine.**

2. While rotating engine to each of 12 screws (17), remove screws to disconnect flywheel (16) from engine flex plate (19).

WARNING

Transmission is heavy. DO NOT remove screws unless transmission is supported. Failure to follow this warning may result in Injury or death to personnel.

3. Support transmission (15) with transmission floor jack.
4. Remove nut (11), bolt (5), and washer (6) holding transmission rear mounting bracket (8) to crossmember (12).
5. Remove rubber mount (7) from transmission rear mounting bracket (8).
6. Remove two bolts (9), lockwashers (10), and transmission rear mounting bracket (8). Discard lockwashers.

6-8. TRANSMISSION REPLACEMENT (Con't).

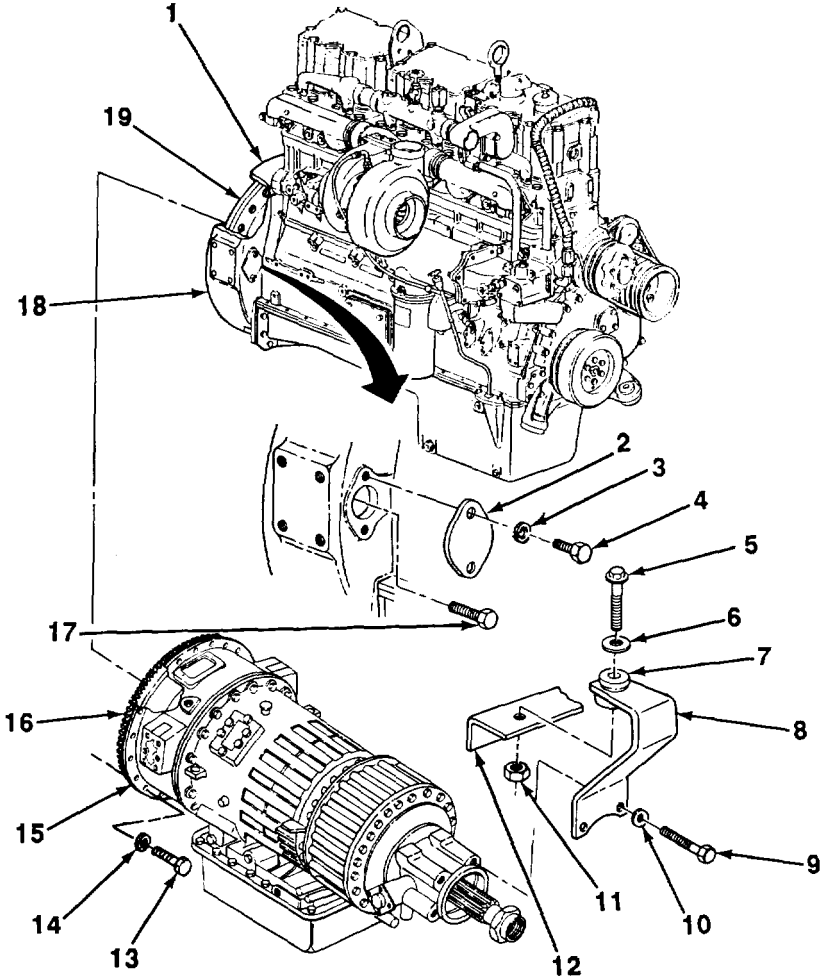

- 7. Remove 12 bolts (13) and washers (14) to separate transmission (15) from engine (1).
- 8. Remove transmission (15).

TA703783

6-8. TRANSMISSION REPLACEMENT (Con't).

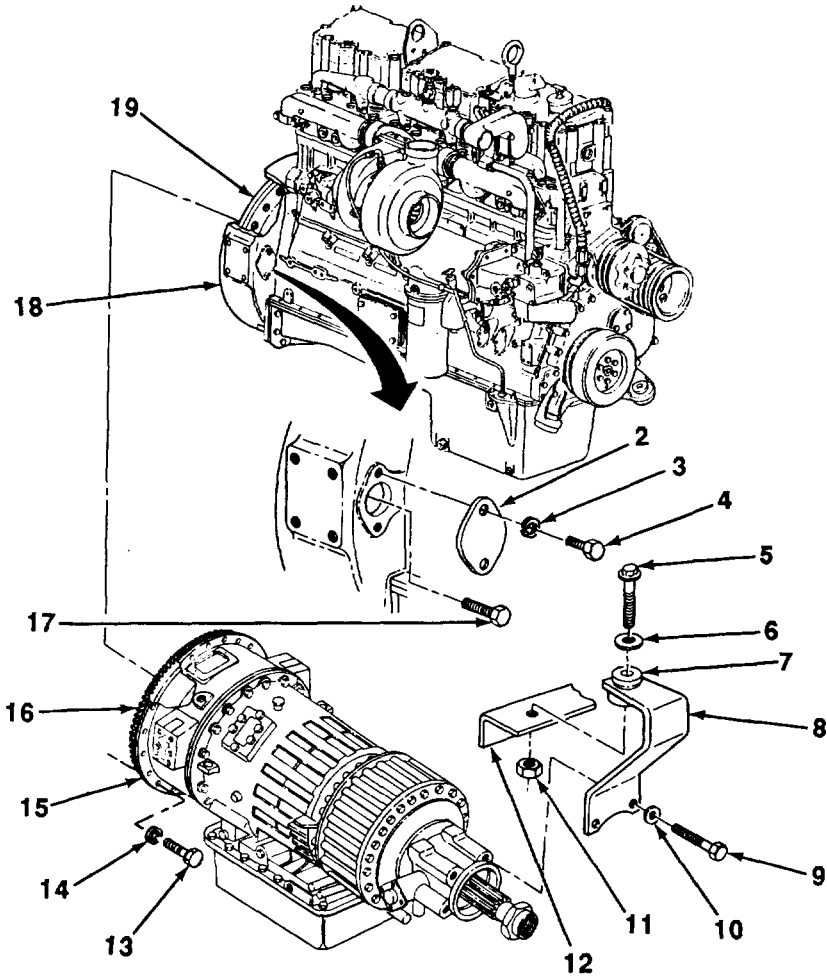

NOTE

If transmission is to be replaced, perform steps 9 and 10.

- 9. Remove the following items from the unserviceable transmission and install on new transmission:
 - (a) Transmission oil pressure switch (see TM 5-3805-254-20)
 - (b) Backup light switch (see TM 5-3805-254-20)

TA703784

6-8. TRANSMISSION REPLACEMENT (Con't).

- (c) Engine compression brake switch (see TM 5-3805-254-20)
 - (d) Transmission oil temperature sender (see TM 5-3805-254-20)
 - (e) Neutral safety switch (see TM 5-3805-254-20)
10. Compare unserviceable transmission to new transmission and transfer all serviceable parts.

b. INSTALLATION**WARNING**

Transmission is heavy. Ensure that transmission is properly supported for installation. Failure to follow this warning may result in injury or death to personnel.

1. Using transmission floor jack, position transmission (15) to engine flywheel housing (18) and install 12 bolts (13) and washers (14). Torque bolts to 96-115 lb.-ft. (130-156 N.m).
2. Install rubber mount (7) to transmission rear mounting bracket (8).
3. Install transmission rear mounting bracket (8) to crossmember (12) with washer (6), bolt (5), and nut (11).
4. Connect transmission to transmission rear mounting bracket (8) with two new lockwashers (10) and bolts (9). Remove transmission floor jack.
5. While rotating engine to each of 12 positions, install 12 screws (17) to connect engine flexplate (19) to flywheel (16). Torque screws to 96-115 lb.-ft. (130-156 N.m).
6. Install housing cover (2) to right side of engine flywheel housing (18) with two new lockwashers (3) and screws (4).

FOLLOW-ON TASKS:

- Install frame tie tube (see paragraph 14-3).
- Install exhaust pipe (see TM 5-3805-254-20).
- Install transmission to auxiliary transmission propeller shaft (see paragraph 7-1).
- Connect transmission shift cable (see TM 5-3805-254-20).
- Install transmission oil filler tube and dipstick (see TM 5-3805-254-20).
- Install transmission oil pressure gage and line fittings (see TM 5-3805-254-20).
- Install transmission modulator valve (see paragraph 6-7).
- Connect transmission wiring harness leads (see paragraph 5-6).
- Connect transmission cooler hoses (see paragraph 6-5).
- Install power take-off (see paragraph 16-1).
- Install floorboards and inserts (see paragraph 15-3).
- Fill with hydraulic fluid (see TM 5-3805-254-20).

6-9. INSTALL AND REMOVE TRANSMISSION FROM OVERHAUL STAND.

This Task Covers:

- a. Install
- b. Remove

Initial Setup:

Equipment Conditions:

- Transmission removed from vehicle (see paragraph 6-7).

Materials/Parts:

- Four lockwashers
- Eight bolts
- Eight nuts

Tools/Test Equipment:

- General mechanic's tool kit
- Field automotive shop set
- Overhaul stand
- Transmission holding fixture

Personnel Required: Two

a. INSTALL

NOTE

Bolts must be removed now, in order to allow separation of torque converter housing from transmission housing in paragraph 6-11.

1. Remove two bolts (2) and lockwashers (3) from each side of transmission (1). Discard lockwashers.

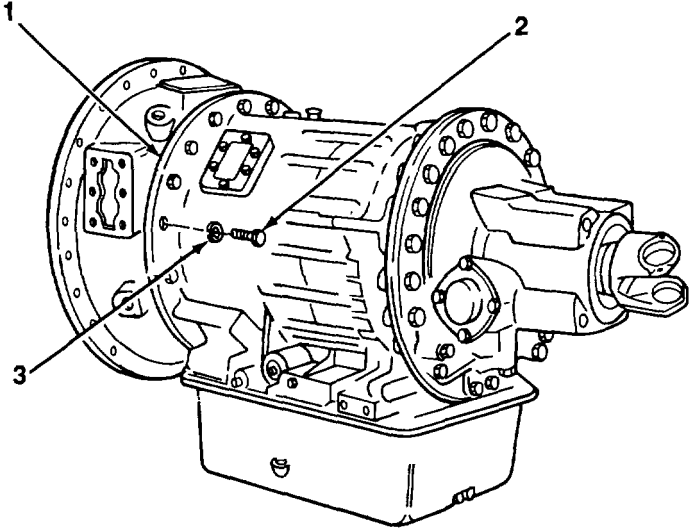

2. Install transmission holding fixture (9) to transmission (1) with four bolts (4) and nuts (8).
3. Attach overhead lifting device to transmission holding fixture (9).

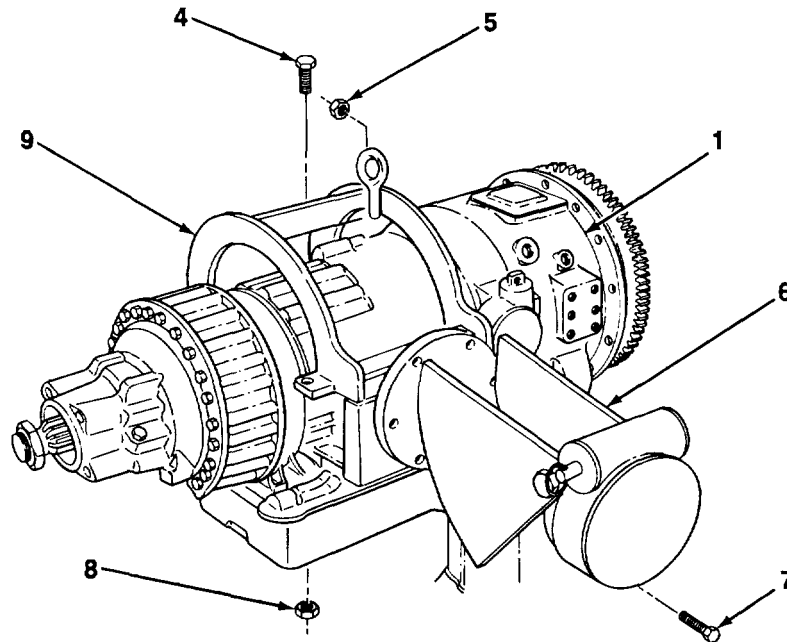
6-9. INSTALL AND REMOVE TRANSMISSION FROM OVERHAUL STAND (Con't).**WARNING**

Transmission is heavy. DO NOT remove screws unless transmission is supported. Failure to follow this warning may result in injury or death to personnel.

4. Raise overhead lifting device and position transmission holding fixture (9) to overhaul stand (6).
5. Install transmission holding fixture (9) to overhaul stand (6) with four bolts (7) and nuts (5).
6. Remove overhead lifting device.

b. REMOVE

1. Attach overhead lifting device to transmission holding fixture (9) and raise just enough to take weight of transmission (1) and transmission holding fixture off overhaul stand (6).

WARNING

Transmission is heavy. DO NOT remove nuts and bolts unless transmission is supported. Failure to follow this warning may result in injury or death to personnel.

2. Remove four nuts (5) and bolts (7) from transmission holding fixture (9) and overhaul stand (6).
3. Move transmission (1) to a safe area and remove four nuts (8), bolts (4), and transmission holding fixture (9).
4. Install two new lockwashers (3) and bolts (2) to each side of transmission (1). Torque bolts to 67-80 lb.-ft. (91-108 N.m).

TA703786

6-10. FLYWHEEL REPLACEMENT.

This Task Covers:

- | | |
|--|---|
| <ul style="list-style-type: none"> a. Removal b. Cleaning and Inspection | <ul style="list-style-type: none"> c. Installation |
|--|---|

Initial Setup:

Equipment Conditions:

Transmission installed on overhaul stand (see paragraph 6-9).

Tools/Test Equipment

- General mechanic's tool kit
- Field automotive shop set
- Flywheel lifting bracket
- Two guide screws

Materials/Parts:

- Hydraulic fluid (Item 7, Appendix B)
- Grease (Item 10, Appendix B)
- Dry cleaning solvent (Item 23, Appendix B)
 - One preformed packing
- Two preformed packing
- Two gaskets
- Two lockwashers

Personnel Required: Two

General Safety Instructions:

- Dry cleaning solvent is flammable and must not be used near open flame. Use only in a well-ventilated area.

a. REMOVAL

1. Remove two bolts (2), lockwashers (3), converter access cover (1), and gasket (4) from top of converter housing (5). Discard lockwashers and gasket.
2. Remove 29 of 30 bolts (8) and washers (7) from converter pump (6).

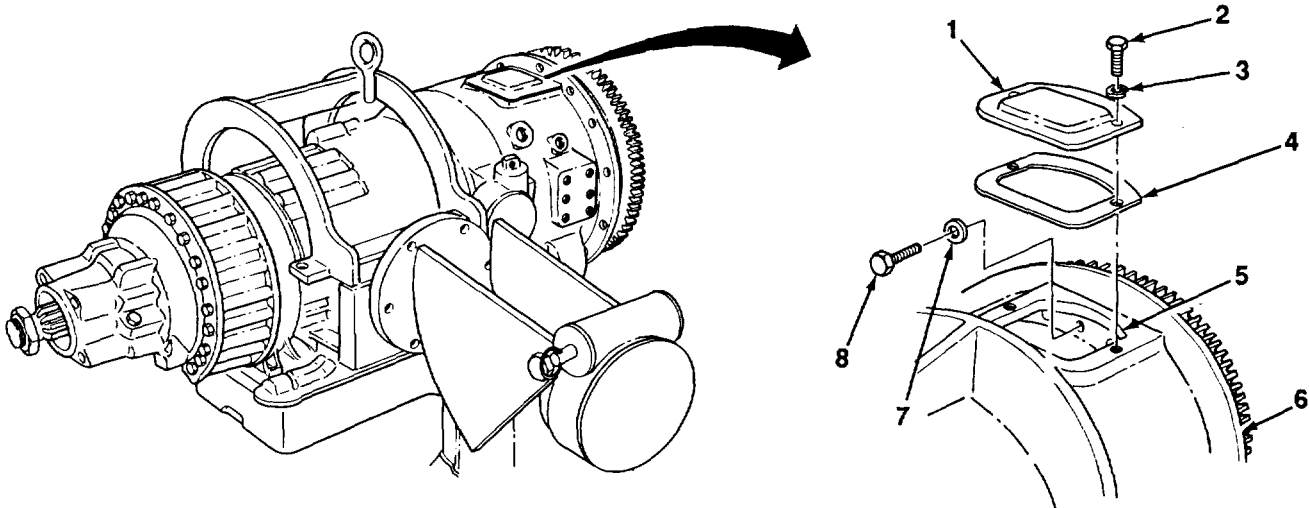

TA703787

6-10. FLYWHEEL REPLACEMENT (Con't).

3. Install flywheel lifting bracket (9) to front of flywheel (12) with two washers (10) and bolts (11).
4. Attach lifting device to flywheel lifting bracket (9) and raise just enough to support weight of flywheel (12) assembly.
5. Remove one remaining bolt (8) and washer (7) from converter pump (6).

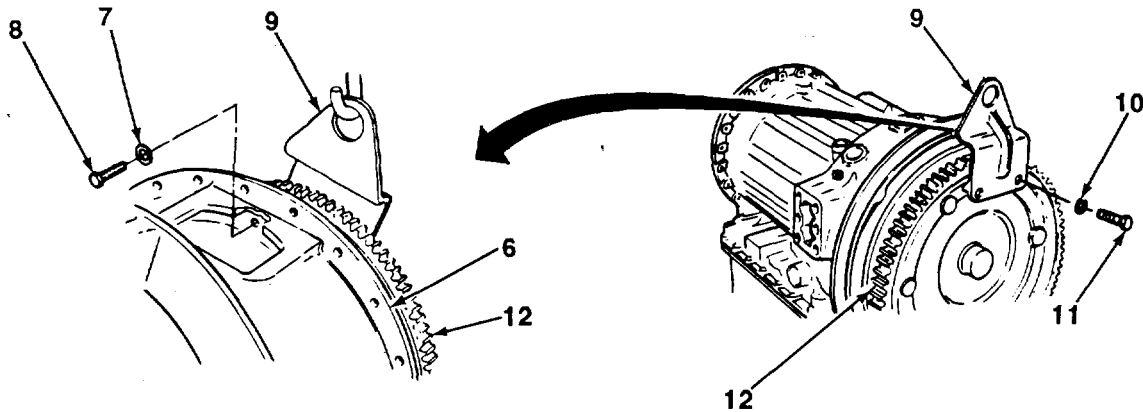

CAUTION

Turbine may be removed with flywheel or remain in transmission. Ensure that turbine does not fall and become damaged.

6. Remove flywheel (12) assembly from converter housing (5).
7. Remove two bolts (11), washers (10), and flywheel lifting bracket (9) from front of flywheel (12).

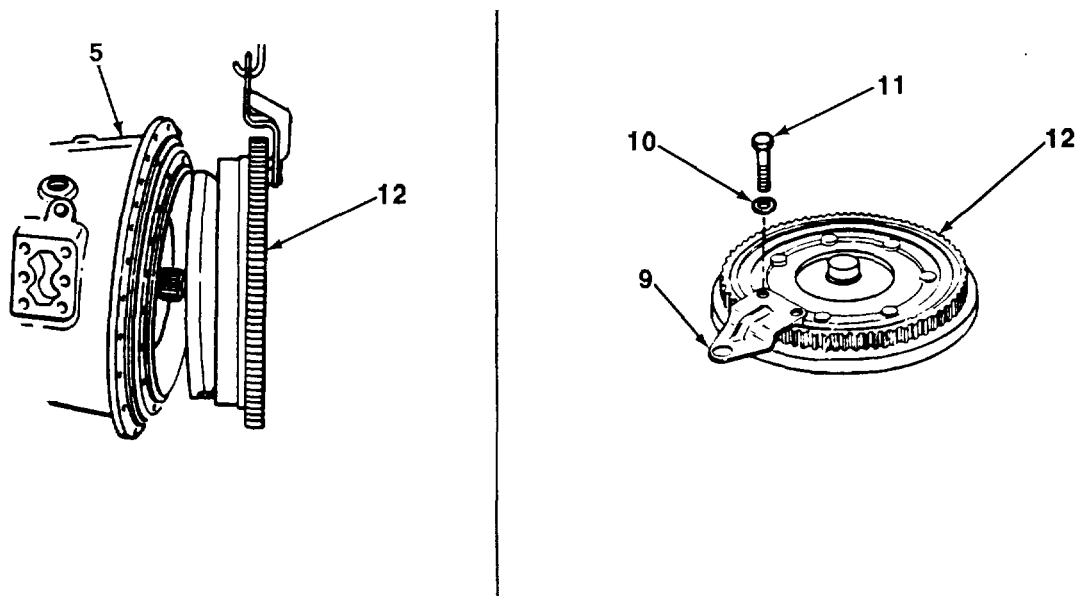

6-10. FLYWHEEL REPLACEMENT (Con't).

8. Place flywheel (12) assembly with front downward on work surface.

CAUTION

Turbine must be pried evenly off flywheel. Use rags at pry points to prevent damage to turbine or flywheel.

9. Remove turbine (13) from flywheel (12) using two prybars.
10. Remove lockup clutch backplate (14) and key (15) from flywheel (12).

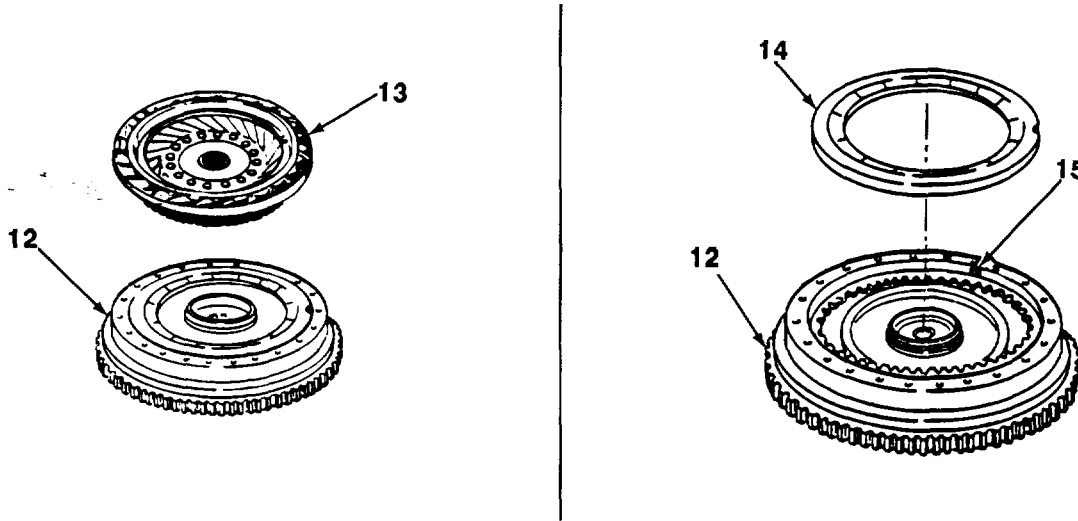

TA703789

6-10. FLYWHEEL REPLACEMENT (Con't).

11. Remove lockup clutch disk (16).
12. Remove lockup clutch piston (18).
13. Remove gasket (17) from outer groove of lockup clutch piston (18). Discard gasket.
14. Remove preformed packing (19) from hub of flywheel (12). Discard preformed packing.

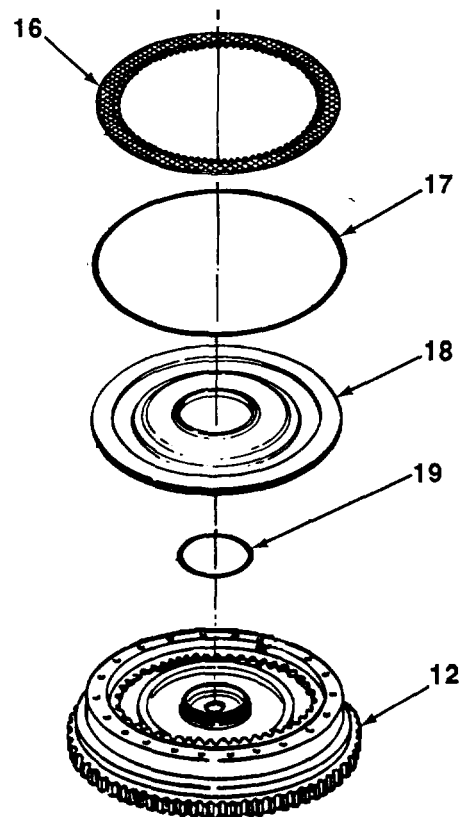
**b. CLEANING AND INSPECTION****WARNING**

Dry cleaning solvent, P-D-680, is toxic and flammable. Always wear protective goggles and gloves, and use only in a well-ventilated area. Avoid contact with skin, eyes, and clothes, and DO NOT breathe vapors. DO NOT use near open flame or excessive heat. The solvent's flash point is 100°F-138°F (38°C-59°C). If you become dizzy while using cleaning solvent, immediately get fresh air and medical help. If solvent contacts eyes, immediately wash your eyes and get medical aid.

1. Clean metal parts with dry cleaning solvent.
2. Inspect metal parts for cracks, breaks, wear, or other damage. Replace if damaged.
3. Inspect flywheel ring gear for chipped, worn, or broken teeth. Replace flywheel if ring gear is damaged.

TA703790

6-10. FLYWHEEL REPLACEMENT (Con't).

- 4. Measure Inner bore (20) of flywheel (12). If diameter is greater than 1.007 in. (2.558 cm), replace flywheel.
- 5. Apply thin coat of hydraulic fluid to surfaces of metal parts, preformed packing, and seal ring.

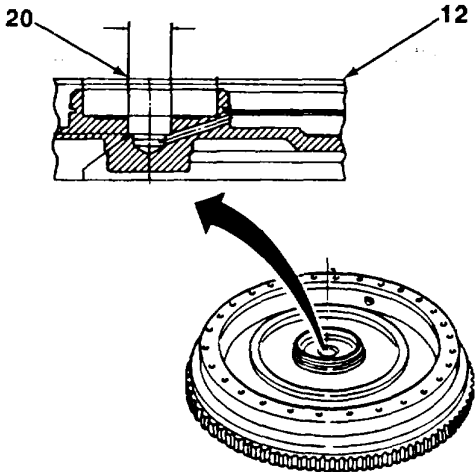

c. INSTALLATION

- 1. Install new preformed packing (19) to hub of flywheel (12).
- 2. Install new gasket (17) into outer groove of lockup clutch piston (18).
- 3. Install lockup clutch piston (18) into flywheel (12). Ensure that dowel pins of flywheel align with holes of lockup clutch piston.
- 4. Install lockup clutch disk (16).

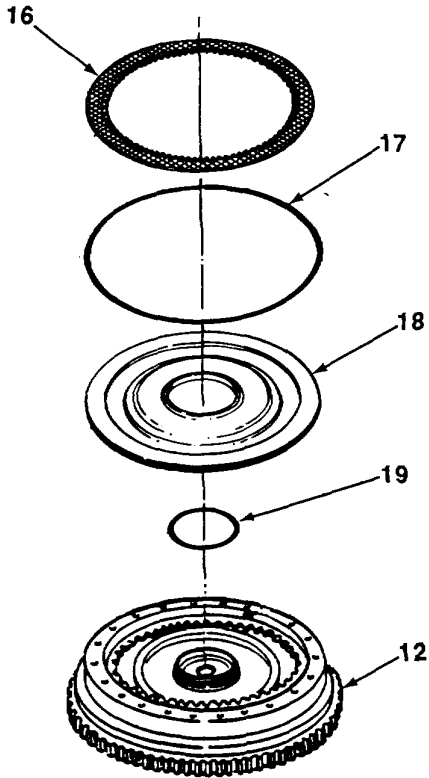

TA703791

6-10. FLYWHEEL REPLACEMENT (Con't).

- 5. Apply grease to key (15) and install key in groove of flywheel (12).
- 6. Install lockup clutch back plate (14). Ensure that notch of lockup clutch backplate aligns with key (15).

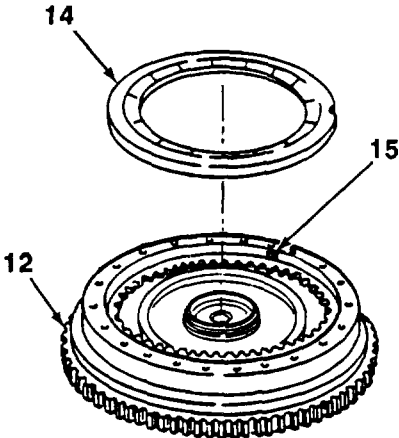

- 7. Center lockup clutch disk (16) in flywheel (12) and install turbine (13) to flywheel. Ensure that splines of turbine mesh with internal teeth of lockup clutch disk.

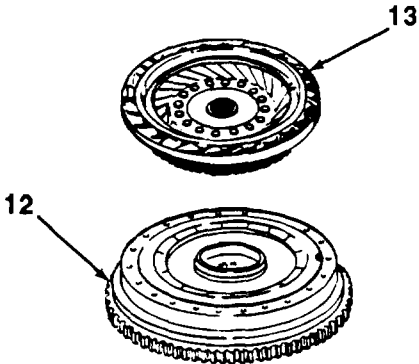

- 8. Install flywheel lifting bracket (9) to front of flywheel (12) with two washers (10) and bolts (11).

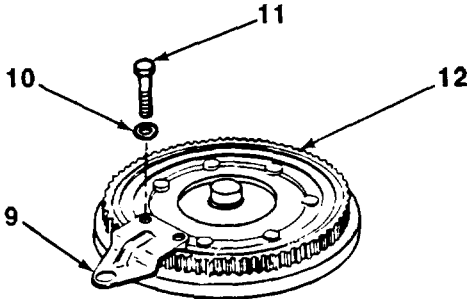

6-10. FLYWHEEL REPLACEMENT (Con't).**CAUTION**

Turbine is loose on flywheel. Ensure that turbine does not fall and become damaged.

9. Attach lifting device to flywheel lifting bracket (9) and raise flywheel (12) assembly to vertical position.
10. Install two guide screws (22) into threaded holes at top and bottom of flywheel (12).
11. Move lifting device to position flywheel (12) assembly to front of transmission (21).
12. Aline flywheel (12) assembly with converter pump (6) using guide screw (22). Ensure that splines of turbine (13) mesh with splines of forward clutch shaft (23).

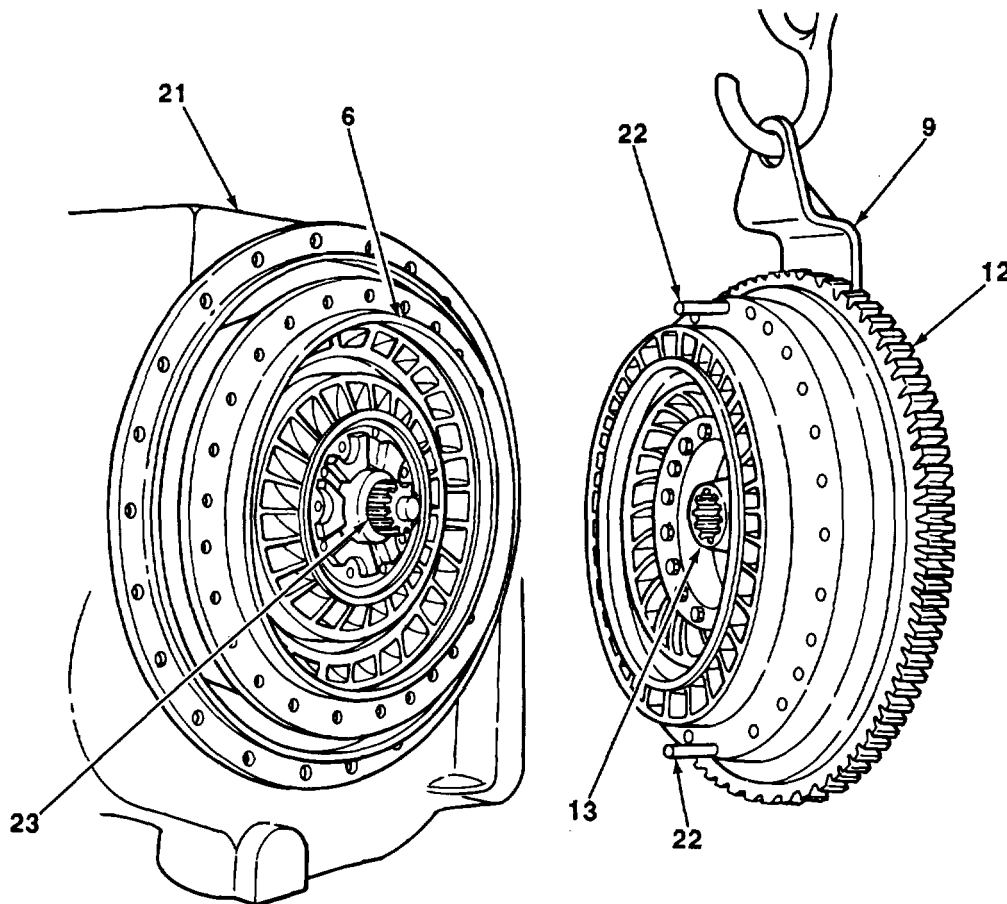

6-10. FLYWHEEL REPLACEMENT (Con't).

13. Install one washer (7) and bolt (8) to secure flywheel (12) assembly to converter pump (6).
14. Remove lifting device, two bolts (11), washers (10), and flywheel lifting bracket (9) from flywheel (12).

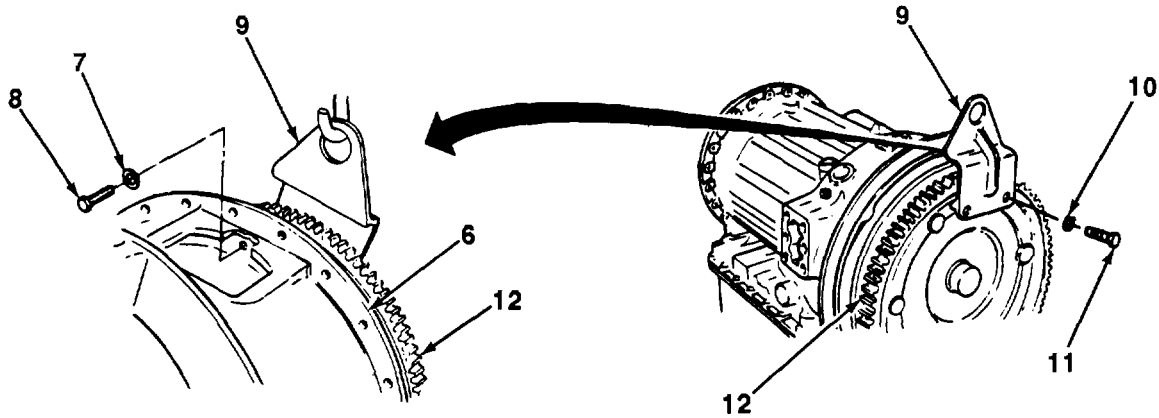

15. Install 28 washers (7) and bolts (8) to converter pump (6).
16. Remove two guide screws (22) to install last washer (7) and bolt (8). Torque bolts to 41-49 lb.-ft. (56-66 N•m).

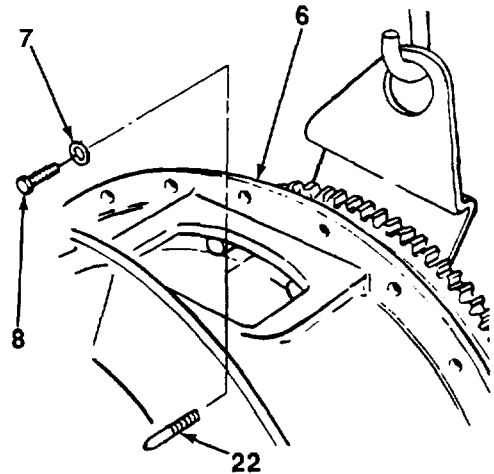

FOLLOW-ON TASKS:

TA703794

- Remove transmission from overhaul stand (see para

6-11. TORQUE CONVERTER REPLACEMENT.

This Task Covers:

- a. Removal
- b. Cleaning and Inspection
- c. Installation

Initial Setup:

Equipment Conditions:

- Flywheel removed (see paragraph 6-10).

Tools/Test Equipment:

- General mechanic's tool kit
- Field automotive shop set
- Converter pump puller
- Stator roller holder

References:

- TM 9-214

Materials/Parts:

- Hydraulic fluid (Item 7, Appendix B)
- Dry cleaning solvent (Item 23, Appendix B)
- One gasket
- One seal
- One seal ring

General Safety Instructions:

Dry cleaning solvent is flammable and must not be used near open flame. Use only in a well-ventilated area.

a. REMOVAL

1. With transmission (1) in a vertical position, rotate stator (2) clockwise to lock stator to roller race (3).
2. Lift stator (2) and roller race (3) from front support ground sleeve (4).

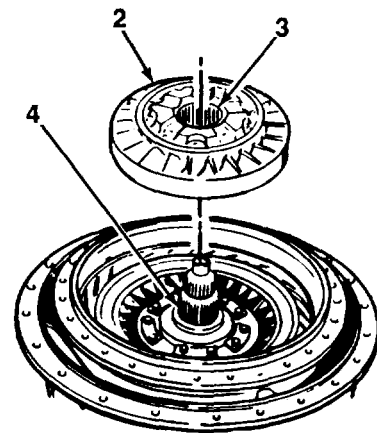
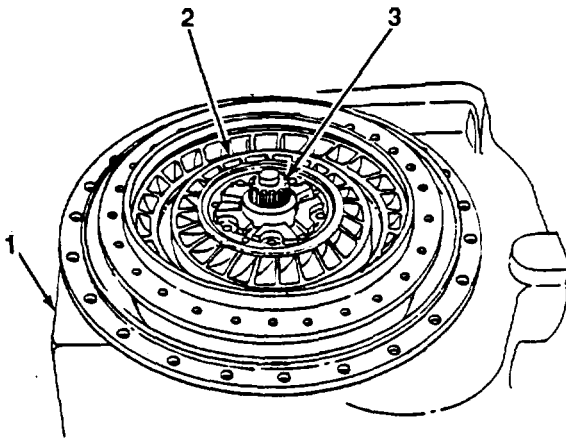

6-11. TORQUE CONVERTER REPLACEMENT (Con't).

3. While holding stator (2), rotate roller race (3) clockwise and remove roller race, thrust bearing (5), and thrust bearing race (6) from stator.

NOTE

Note position of rollers and springs in stator for installation.

4. Remove ten rollers (7) and springs (8) from stator (2).

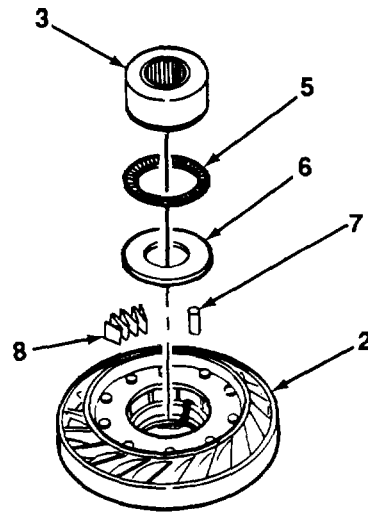

5. Remove snapping (9) and spacer (10) from front support ground sleeve (4).

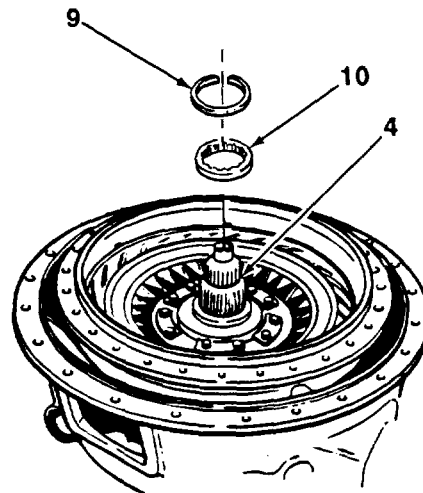

6-11. TORQUE CONVERTER REPLACEMENT

- 6. Remove converter pump (11) assembly from transmission (1) using puller.

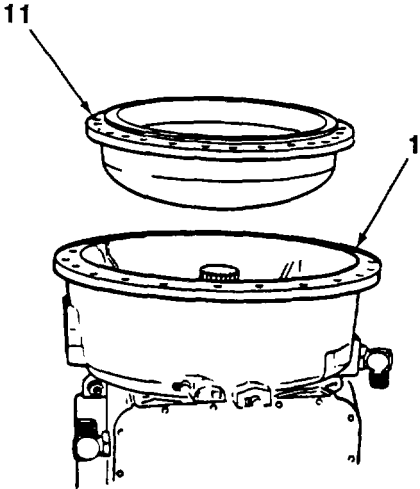

- 7. Flatten corners of six lockstrips (13) and remove 12 bolts (12) and lockstrips from converter pump (11).

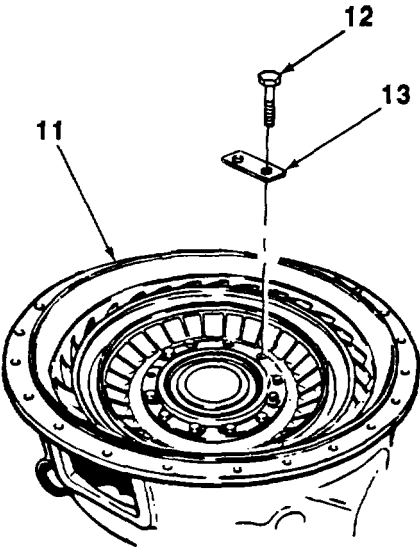

TA703797

6-11. TORQUE CONVERTER REPLACEMENT

8. Remove two bearing retainers (14), converter pump hub (18), and gasket (19) from converter pump (11). Discard gasket.
9. Remove seal ring (15) from converter pump (11). Discard seal ring.
10. Remove seal (17) from converter pump hub (18).
Discard seal.

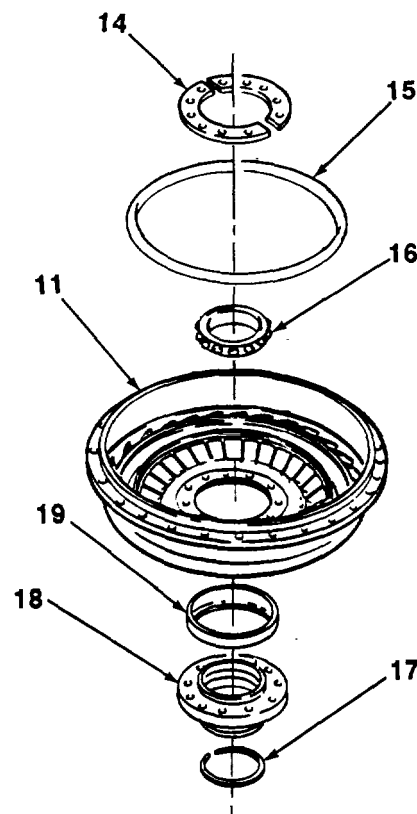
**b. CLEANING AND INSPECTION****WARNING**

Dry cleaning solvent, P-D-680, is toxic and flammable. Always wear protective goggles and gloves, and use only in a well-ventilated area. Avoid contact with skin, eyes, and clothes, and DO NOT breathe vapors. DO NOT use near open flame or excessive heat. The solvent's flash point is 100°F-138°F (38°C-59°C). If you become dizzy while using cleaning solvent, immediately get fresh air and medical help. If solvent contacts eyes, immediately wash your eyes and get medical aid.

1. Clean metal parts with dry cleaning solvent.
2. Inspect metal parts for cracks, breaks, wear, or other damage. Replace if damaged.
3. Inspect bearings for wear or damage (see TM 9-214). Replace if damaged. If bearing (16) in converter pump hub (18) is damaged, press out bearing. Press new bearing into converter pump hub ungrooved end first.
4. Apply thin coat of hydraulic fluid to surfaces of metal parts, bearings, seal ring, and seal.

TA703798

6-11. TORQUE CONVERTER REPLACEMENT

c. INSTALLATION

1. Install new seal (17) to converter pump hub (18).
2. Install new seal ring (15) to converter pump (11).
3. Install new gasket (19) and converter pump hub (18) to converter pump (11) and two bearing retainers (14).
4. Install six lockstrips (13) and 12 bolts (12). Torque bolts to 33-40 lb.-ft. (45-54 N-m).
5. Bend one lockstrip (13) corner upward against each bolt (12)

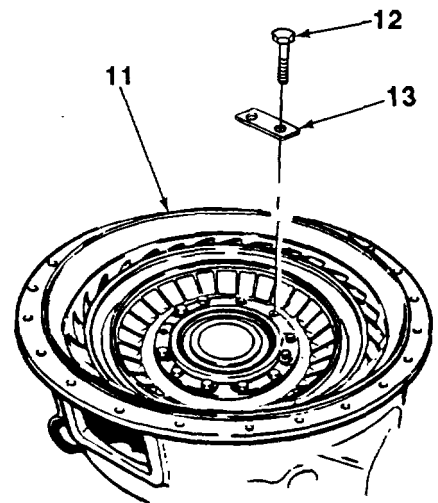
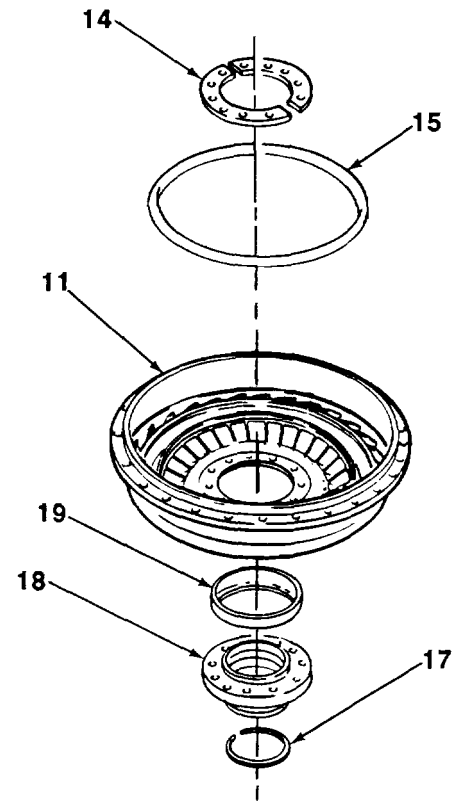

TA703799

6-11. TORQUE CONVERTER REPLACEMENT (Con't).

NOTE

- Bearing In converter pump hub is a press fit on ground sleeve. It may be necessary to heat bearing with 3000F (1 49°C) oil before Installation.
- Aline slot In converter pump hub with tang on oil pump drive gear when Installing.

6. Install converter pump (11) assembly to transmission (1).
7. Install spacer (10) and snapping (9) on front support ground sleeve (4).

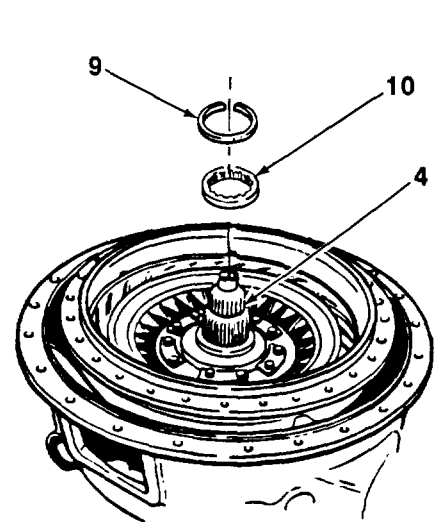
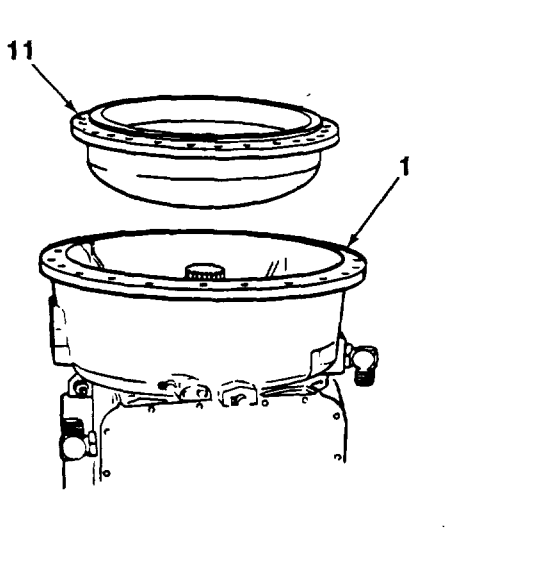

8. Install thrust bearing race (6) into stator (2).

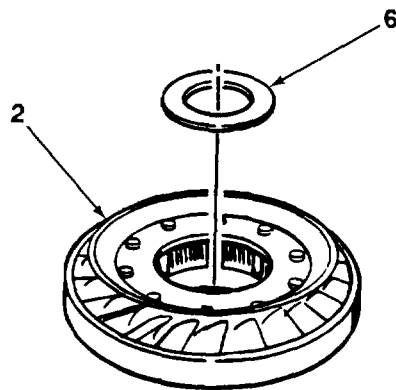

6-11. TORQUE CONVERTER REPLACEMENT

- 9. Position stator roller holder (20) into stator (2) against thrust bearing race (6).
- 10. Install ten springs (8) into spring pockets of stator (2).
- 11. Install ten rollers (7) using stator roller holder (20) to keep rollers in place.

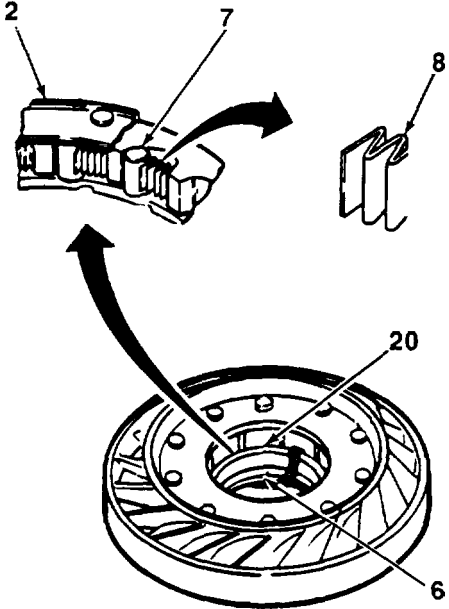

- 12. Position thrust bearing (5) on roller race (3) and install roller race into stator (2) while rotating roller race clockwise. Remove stator roller holder (20) as roller race is installed.
- 13. Rotate roller race (3) counterclockwise slightly to lock roller race to stator (2).

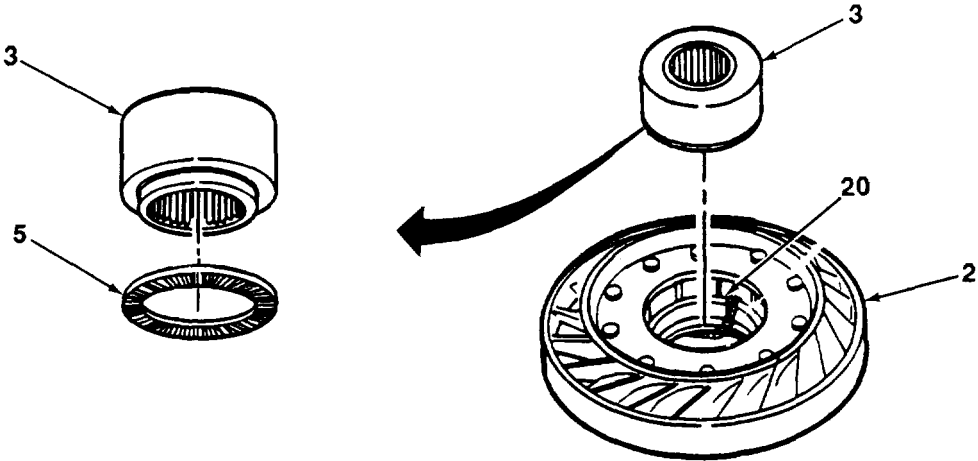

TA703801

6-11. TORQUE CONVERTER REPLACEMENT (Con't).

14. Install stator (2) to front support ground sleeve (4).

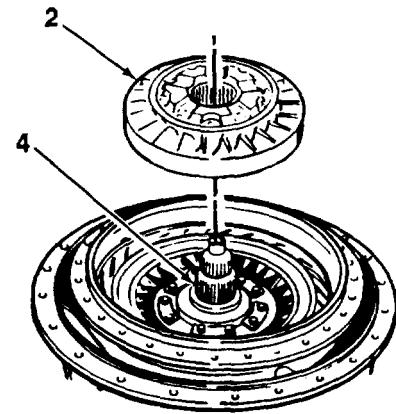

15. Rotate transmission (1) to horizontal position.

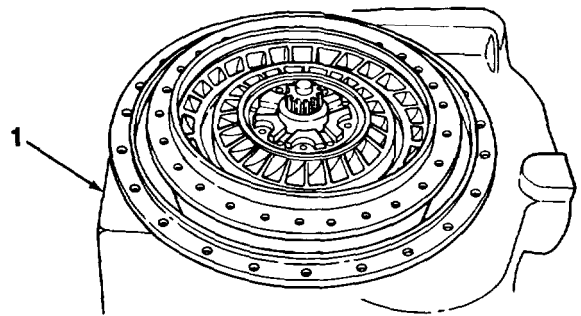
**FOLLOW-ON TASKS:**

- Install flywheel (see paragraph 6-10).

TA703802

6-12. TRIMMER VALVE REPLACEMENT.

This Task Covers:

a. Removal

b. Installation

Initial Setup:

Equipment Conditions:

- Transmission oil filter removed (see TM 5-3805-254-20)

Tools/Test Equipment:

- General mechanic's tool kit
 - Field automotive shop set
-

a. REMOVAL

1. Remove signal pipe (3) from control valve (4).
2. Remove six bolts (1) and trimmer valve (2) from top of low shift valve (5).

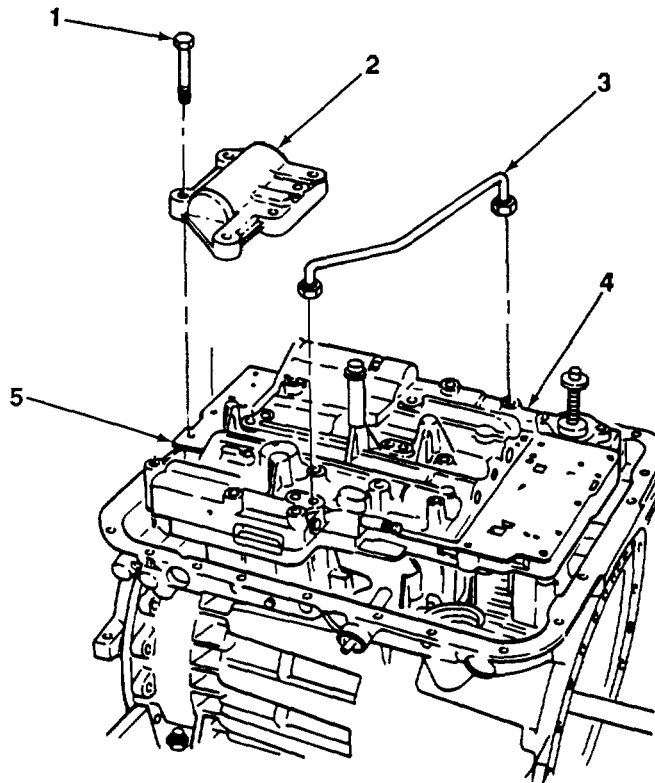

6-12. TRIMMER VALVE REPLACEMENT (Con't).

b. INSTALLATION

1. Install trimmer valve (2) to top of low shift valve (5) with six bolts (1). Torque bolts to 8-12 lb.-ft (11-16 N•m).
2. Install signal pipe (3) to control valve (4).

FOLLOW-ON TASKS:

- Install transmission oil filter (see TM 5-3805-254-20).

6-13. LOW SHIFT VALVE REPLACEMENT.

This Task Covers:

a. Removal

b. Installation

Initial Setup:

Equipment Conditions:

- Trimmer valve removed (see paragraph 6-12)

Tools/Test Equipment:

- General mechanic's tool kit
 - Field automotive shop set
-

a. REMOVAL

1. Remove bolt (1) from low shift valve (2).
2. Remove low shift valve (2) from control valve (3).

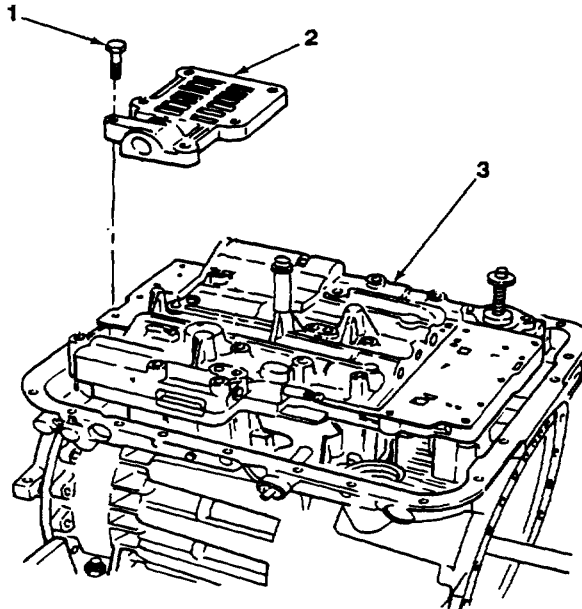

b. INSTALLATION

1. Position low shift valve (2) to control valve (3).
2. Install bolt (1) Torque bolt to 8-12 lb.-ft. (11-16 N•m).

FOLLOW-ON TASKS:

- Install trimmer valve (see paragraph 6-12).

6-14 CONTROL VALVE REPLACEMENT.

This Task Covers:

a. Removal

b. Installation

Initial Setup:

Equipment Conditions:

- Low shift valve removed (see paragraph 6-13)

Tools/Test Equipment:

- General mechanic's tool kit
 - Field automotive shop set
-

a. REMOVAL

1. Remove eight bolts (5) and cover plate (6) from separator plate (10).
2. Remove bolt (3) and selector lever spring (2) from control valve (15).

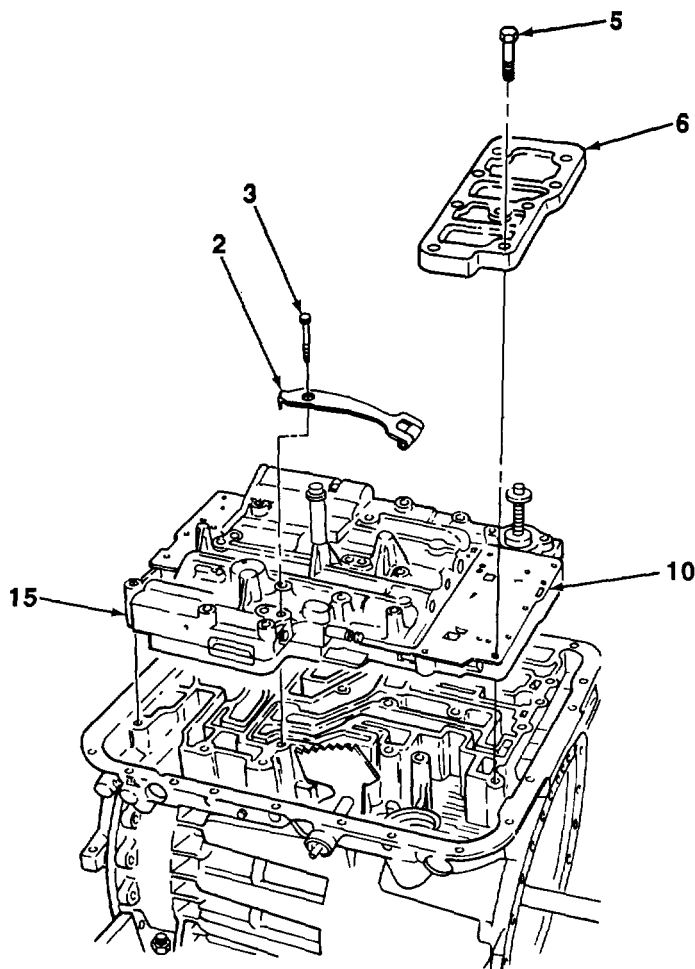

6-14. CONTROL VALVE REPLACEMENT (Con't)

NOTE
Note position of lockwashers for installation.

- 3. Remove two bolts (17) and lockwashers (16) Discard lockwashers.

NOTE
Do not remove bolt that retains selector valve at this time.

- 4. Remove 15 bolts (4) and three bolts (1) from control valve (15). Do not remove bolt (12) holding selector valve (11).
- 5. Remove two bolts (7) and oil baffle (8) from transfer plate (9).
- 6. Remove control valve (15), separator plate (10), and transfer plate (9) from transmission housing (14) as an assembly.

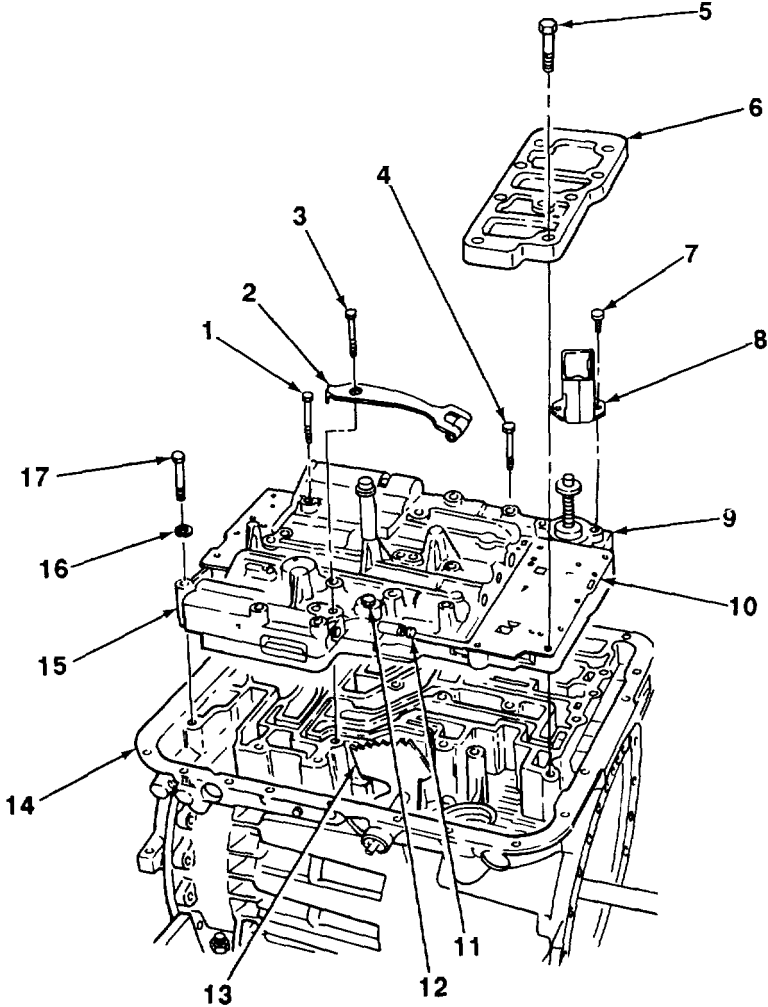

6-14. CONTROL VALVE REPLACEMENT (Con't).

b. INSTALLATION

- 1 Ensure that pin on selector lever (13) engages selector valve (11) and install control valve (15), separator plate (10), and transfer plate (9), as an assembly, to transmission housing (14).
- 2 Install oil baffle (8) to transfer plate (9) with two bolts (7).
- 3 Install 15 bolts (4) and three bolts (1) to control valve (15).
- 4 Install two new lockwashers (16) and bolts (17).
- 5 Install selector lever spring (2) to control valve (15) with bolt (3).
- 6 Install cover plate (6) to separator plate (10) with eight bolts (5).
- 7 Torque all bolts to 8-12 lb.-ft (11-16 N•m).

FOLLOW-ON TASKS:

- Install low shift valve (see paragraph 6-13).

6-15. OIL PUMP, FRONT SUPPORT, AND CONVERTER HOUSING REPLACEMENT.*This Task Covers:*

- | | |
|----------------------------|-----------------|
| a. Removal | c. Installation |
| b. Cleaning and Inspection | |

*Initial Setup:***Equipment Conditions:**

- Torque converter removed (see paragraph 6-11)

Tools/Test Equipment:

- General mechanic's tool kit
- Field automotive shop set
- Two guide screws, pitot tube
- Two lifting eyes and nuts

Personnel Required: Two**Materials/Parts:**

- Grease (Item 10, Appendix B)
- Dry cleaning solvent (Item 23, Appendix B)
- One gasket
- Two seal rings
- Fourteen lockwashers

General Safety Instructions:

- Dry cleaning solvent is flammable and must not be used near open flame. Use only in a well-ventilated area.

a. REMOVAL**NOTE****Removal of screws and washers will free pitot tube under converter of housing.**

1. With transmission in a vertical position, remove two small screws (2) and washers (1) from inside converter housing (5).
2. Remove seven screws (3) and lockwashers (4).

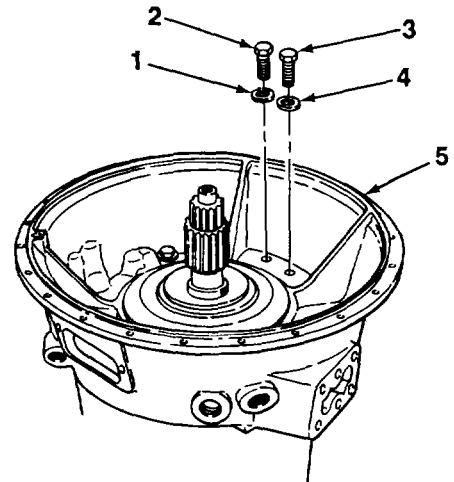

TA703807

6-15. OIL PUMP, FRONT SUPPORT, AND CONVERTER HOUSING REPLACEMENT

- 3. Remove seven bolts (8) and lockwashers (9) from transmission housing (10). Discard lockwashers.
- 4. Install two lifting eyes (6) and nuts (7) to converter housing (5) and attach lifting device to lifting eyes.
- 5. Lift converter housing (5) from transmission housing (10) and move to work surface. Remove two nuts (7) and lifting eyes (6) and place front of converter housing facing downward.

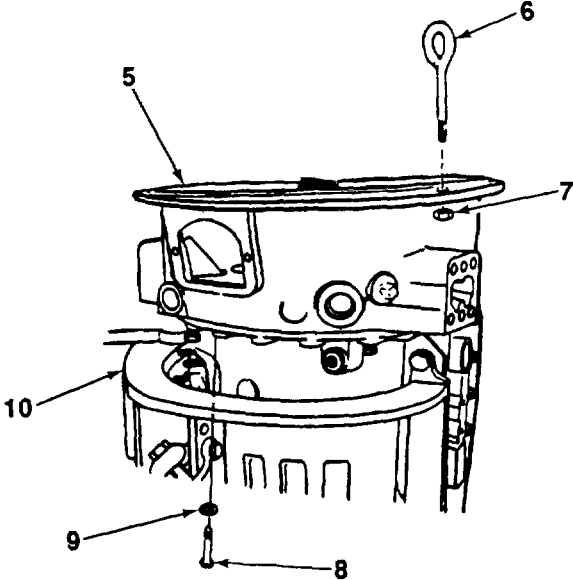

- 6. Remove pitot tube (11) remaining in transmission housing (10).

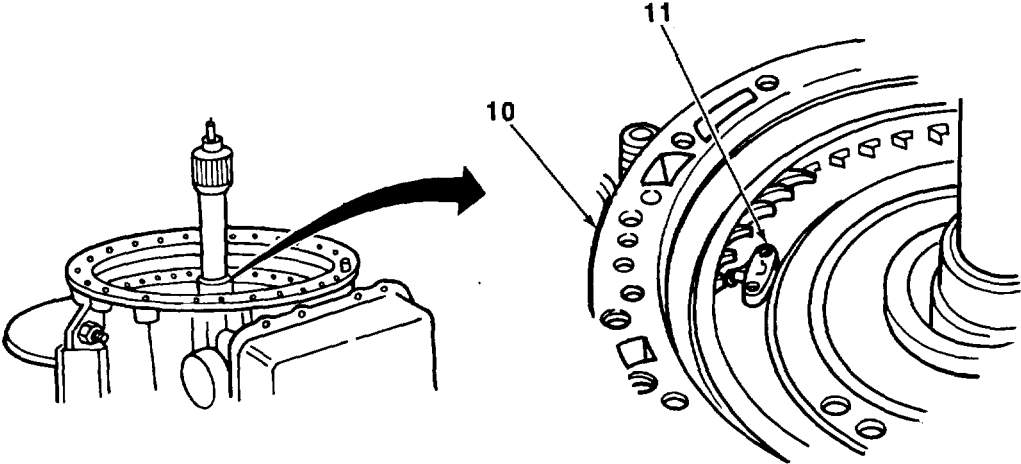

6-15. OIL PUMP, FRONT SUPPORT, AND CONVERTER HOUSING REPLACEMENT Con't.

- 7 Remove two seal rings (12), thrust bearing (13), and bearing ring (14) from front support (15). Discard seal rings.
8. Remove four of six long bolts (18) holding oil pump (17) to converter housing (5). Loosen remaining two long bolts enough to expose some threads.

NOTE

Wood board is used to cushion oil pump as it falls free of converter housing.

- 9 Position wood board through access hole in side of converter housing (5).
- 10 Alternately tap on heads of two remaining long bolts (18) to loosen oil pump (17).
- 11 Remove seal ring (16) from oil pump (17).

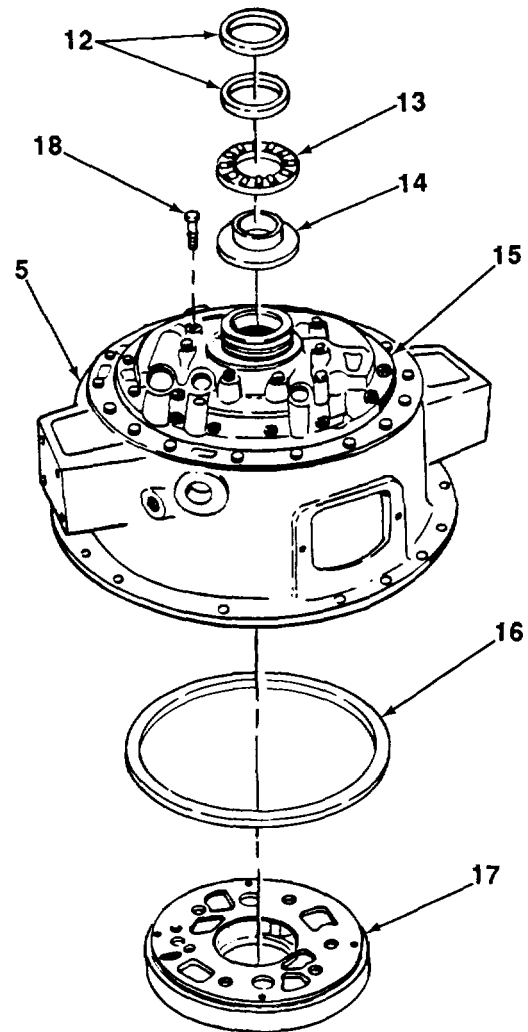

TA703809

6-15. OIL PUMP, FRONT SUPPORT, AND CONVERTER HOUSING REPLACEMENT (Con't).

12. Remove three bolts (19), 16 bolts (20), front support (15), and gasket (21) from converter housing (5). Discard gasket.

b. CLEANING AND INSPECTION**WARNING**

Dry cleaning solvent, P-D-680, is toxic and flammable. Always wear protective goggles and gloves, and use only in a well-ventilated area. Avoid contact with skin, eyes, and clothes, and DO NOT breathe vapors. DO NOT use near open flame or excessive heat. The solvent's flash point is 100°F-138°F (38°C-59°C). If you become dizzy while using cleaning solvent, immediately get fresh air and medical help if solvent contacts eyes, immediately wash your eyes and get medical aid.

1. Clean converter housing with dry cleaning solvent.
2. Inspect converter housing for cracks, breaks, distortion, or other damage. Replace if damaged.

c. INSTALLATION

1. Place front of converter housing (5) on work surface facing downward.
2. Position new gasket (21) on converter housing (5) with holes in gasket aligned with holes of converter housing.
3. Install front support (15) with three bolts (19). Torque bolts to 36-43 lb.-ft. (49-58 N•m).
4. Install one of 16 bolts (20) into hole between two valve bores in front support (15) that are closer to each other. Torque bolts to 36-43 lb.-ft. (49-58 N•m).
5. Install remaining 15 bolts (20) into outer bolt circle of front support (15). Torque bolts to 36-43 lb.-ft. (49-58 N•m).

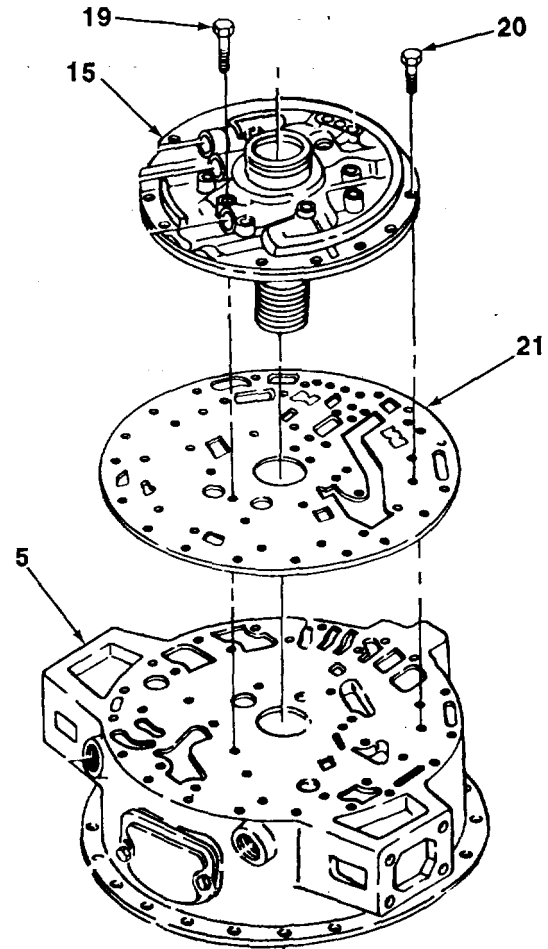

TA703810

6-15. OIL PUMP, FRONT SUPPORT, AND CONVERTER HOUSING REPLACEMENT (Con't).

6. Apply coat of grease to surface of bearing ring (14), thrust bearing (13), and two new seal rings (12).
7. Install flat side first, bearing ring (14), thrust bearing (13), and two new seal rings (12) to front support (15).
8. Turn converter housing (5) over and install seal ring (16).
9. While holding converter housing (5) in a vertical position, Install oil pump (17) to converter housing with six long bolts (18). Torque bolts to 36-43 lb.-ft. (49-58 N•m).

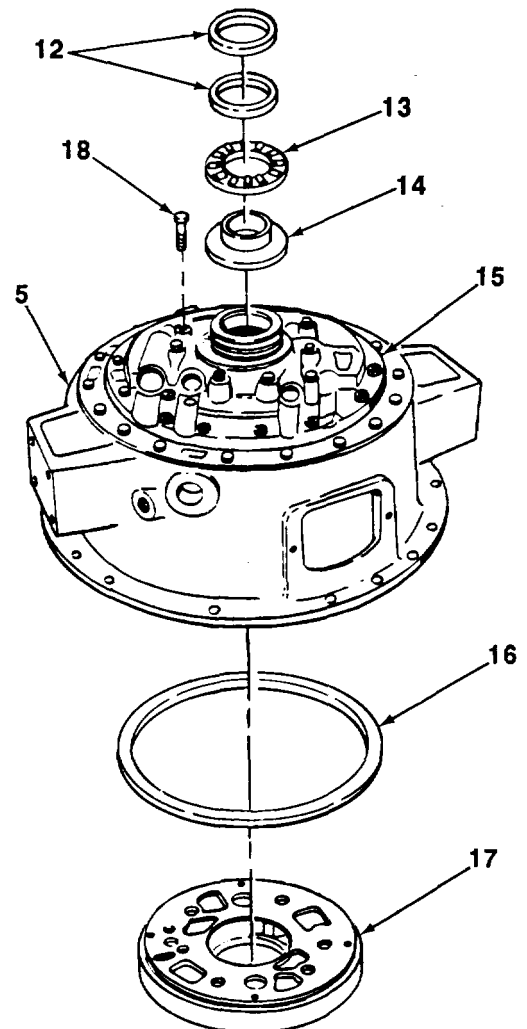

6-15. OIL PUMP, FRONT SUPPORT, AND CONVERTER HOUSING REPLACEMENT (Con't).

NOTE

Ensure that exit port of pitot tube faces guide screws.

10. Install two guide screws (22) to pitot tube (11).

NOTE

Ensure that entrance port of pitot tube faces outward.

11. Install guide screws (22) and pitot tube (11) into converter housing (5).

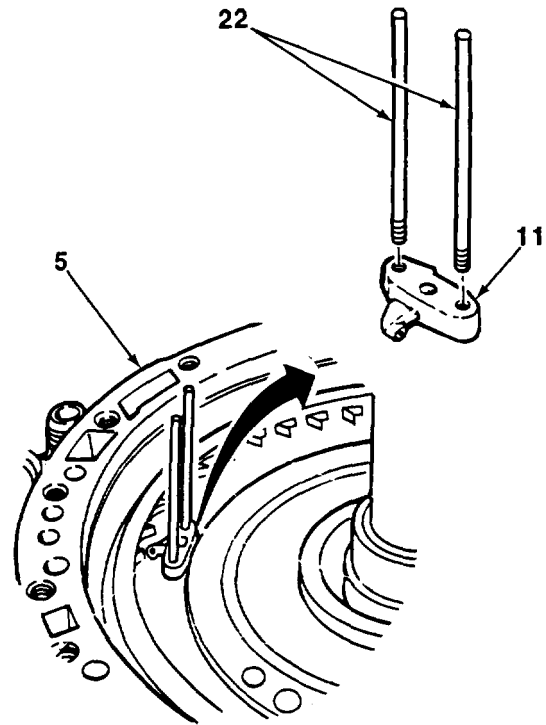

12. Install two lifting eyes (6) and nuts (7) to converter housing (5) and attach lifting device to lifting eyes.

13. Raise converter housing (5) from work surface and move to transmission housing (10).

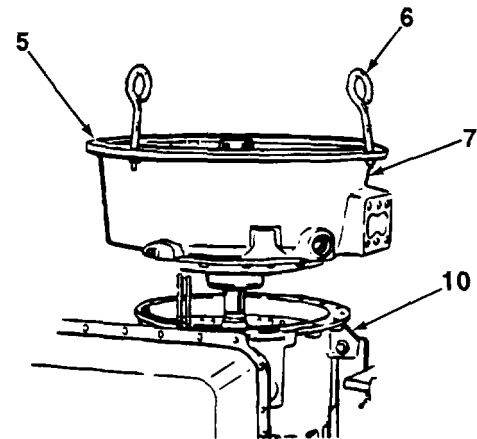

6-15. OIL PUMP, FRONT SUPPORT, AND CONVERTER HOUSING REPLACEMENT (Con't).**CAUTION**

Do not damage pitot tube.

NOTE

Ensure that thrust bearing and bearing ring are still in place on front support.

14. Install converter housing (5) to transmission housing (10) with seven screws (3) and new lockwashers (4) inside converter housing. Torque screws to 67-80 lb.-ft. (91-108 N•m).
15. Remove one guide screw (22) and install one washer (1) and small screw (2) to secure pitot tube (11) to converter housing (5).
16. Remove other guide screw (22) and install other washer (1) and small screw (2). Torque screws to 30-48 lb.-ft. (41-65 N•m).

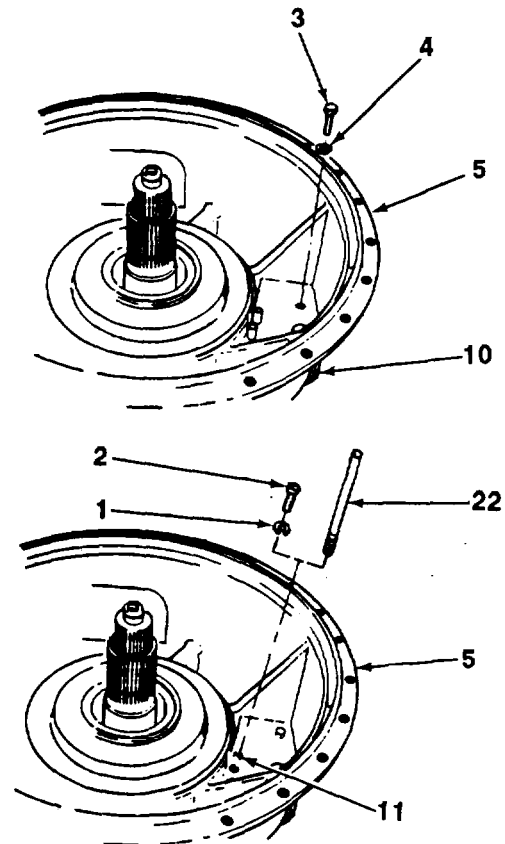

TA703813

6-15. OIL PUMP, FRONT SUPPORT, AND CONVERTER HOUSING REPLACEMENT (Con't).

17. Install seven new lockwashers (9) and bolts (8) through transmission housing (10) into converter housing (5). Torque bolts to 67-80 lb.-ft (91-108 N•m).
18. Remove two lifting eyes (6) and nuts (7) from converter housing (5).

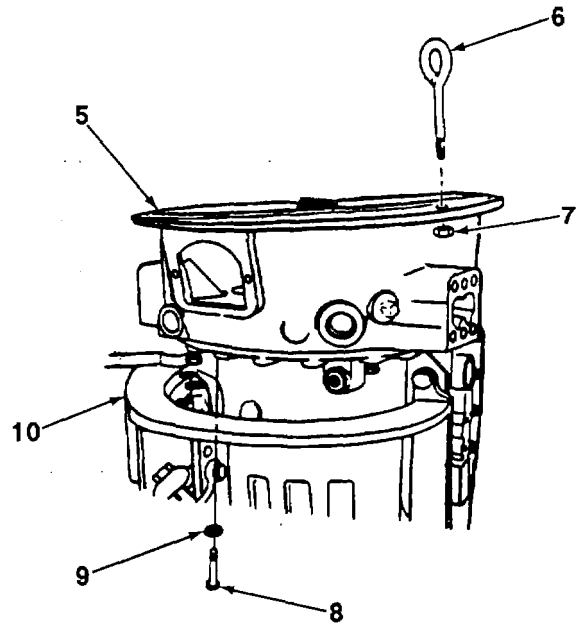
**FOLLOW-ON TASKS:**

- Install torque converter (see paragraph 6-11).

6-16. INPUT SHAFT AND FORWARD CLUTCH REPLACEMENT.

This Task Covers:

- a. Removal b. Installation
-

Initial Setup:

Equipment Conditions:

- Oil pump, front support, and converter housing removed (see paragraph 6-15)

Materials/Parts:

- Grease (Item 10, Appendix B)
- Three seal rings

Tools/Test Equipment:

- General mechanic's tool kit
-

a. REMOVAL

1. Remove seal ring (1) from front of input shaft (10). Discard seal ring.
2. Remove bearing race (2) from hub of forward clutch housing (4).
3. Remove two seal rings (3) from input shaft (10). Discard seal rings.
4. Remove Input shaft (10) and forward clutch housing (4) as an assembly from transmission housing (9).
5. Remove bearing race (6), roller bearing (7), and bearing ring (8) from forward clutch hub (5).

6-16. INPUT SHAFT AND FORWARD CLUTCH REPLACEMENT (Con't).**b. INSTALLATION**

1. Apply thin coat of grease to surface of new seal rings (1 and 3), bearing races (2 and 6), roller bearing (7), and bearing ring (8).
2. Install bearing ring (8), flat side first, roller bearing (7), and bearing race (6) to forward clutch hub (5).
3. Install input shaft (10) and forward clutch housing (4) as an assembly into transmission housing (9).
4. Install two seal rings (3) on input shaft (10).
5. Install bearing race (2) over input shaft (10) and onto hub of forward clutch housing (4).
6. Install seal ring (1) to front of input shaft (10).

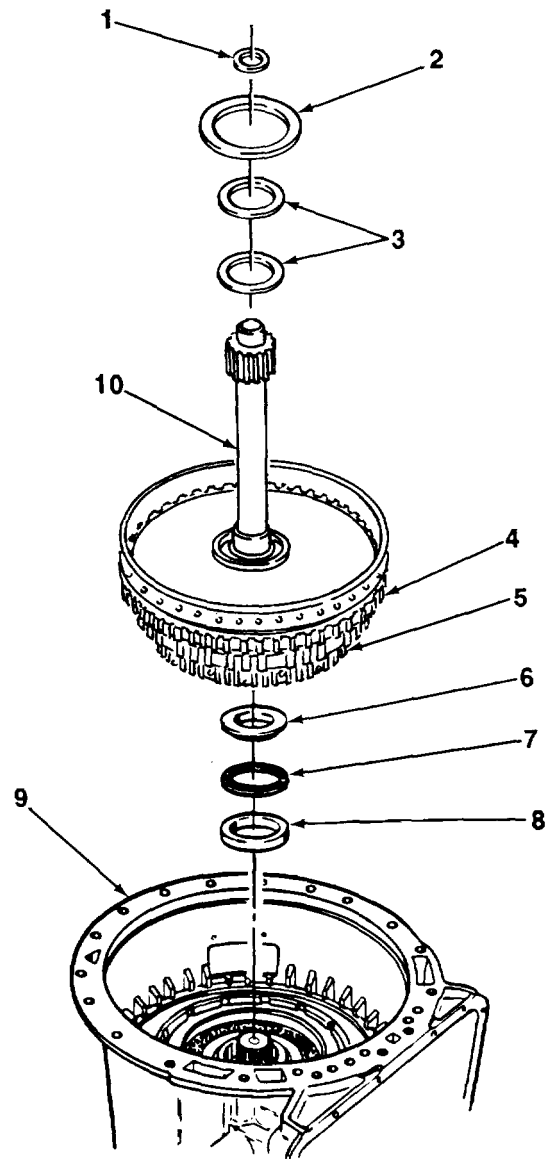
**FOLLOW-ON TASKS:**

- Install oil pump, front support, and converter housing (see paragraph 6-15).

TA703815

6-17. FOURTH CLUTCH REPLACEMENT.

This Task Covers:

a. Removal

b. Installation

Initial Setup:

Equipment Conditions:

- Input shaft and forward clutch removed (see paragraph 6-16).

Materials/Parts:

- Grease Item 10, Appendix B)

Tools/Test Equipment:

- General mechanic's tool kit

a. REMOVAL

1. Remove fourth clutch (1) from transmission housing (4) and shaft (3).
2. Remove bearing race (2) from fourth clutch (1).

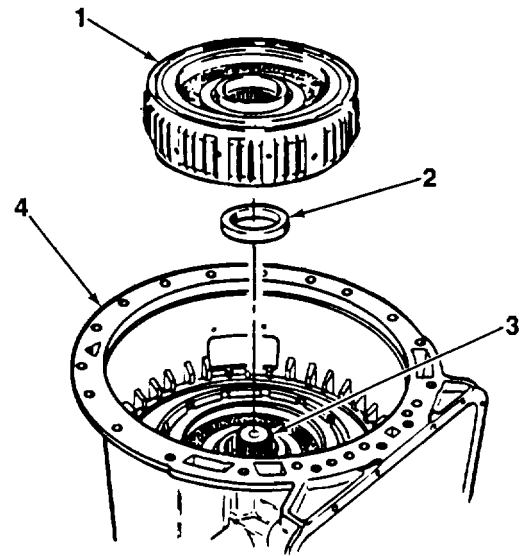
**b. INSTALLATION**

1. Apply thin coat of grease to surface of bearing race (2).
2. Install bearing race (2) to rear of fourth clutch (1).
3. Install fourth clutch (1) to transmission housing (4).

FOLLOW-ON TASKS:

- Install input shaft and forward clutch (see paragraph 6

6-18. THIRD CLUTCH REPLACEMENT.*This Task Covers:*

- | | |
|----------------------------|-----------------|
| a. Removal | c. Installation |
| b. Cleaning and Inspection | |

*Initial Setup:***Equipment Conditions:**

- Fourth clutch removed (see paragraph 6-17)

Tools/Test Equipment:

- General mechanic's tool kit
- Field automotive shop set

Materials/Parts:

- Hydraulic fluid (Item 7, Appendix B)
- Grease, (Item 10, Appendix B)
- Dry cleaning solvent (Item 23, Appendix B)
- General Safety Instructions:
- Dry cleaning solvent is flammable and must not be used near open flame. Use only in a well-ventilated area.

a. REMOVAL

1. Remove snapping (1) and third clutch backing plate (2) from transmission housing (6).

NOTE

One external tooth clutch plate (last to be removed) is slightly thicker than others. Note location of thicker plate for installation.

2. Remove four clutch plates (3), three external tooth clutch plates (4), and one external tooth clutch plate (5).

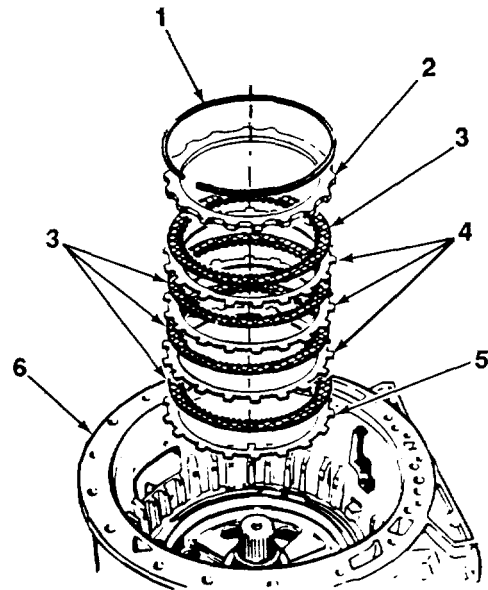

TA703817

6-18. THIRD CLUTCH REPLACEMENT (Con't).

b. CLEANING AND INSPECTION

WARNING

Dry cleaning solvent, P-D-680, is toxic and flammable. Always wear protective goggles and gloves, and use only in a well-ventilated area. Avoid contact with skin, eyes, and clothes, and DO NOT breathe vapors. DO NOT use near open flame or excessive heat. The solvent's flash point is 100°F-138°F (38°C-59°C). If you become dizzy while using cleaning solvent, immediately get fresh air and medical help. If solvent contacts eyes. Immediately wash your eyes and get medical aid.

1. Clean metal parts, except clutch plates, with dry cleaning solvent.
2. Inspect metal parts for cracks, breaks, wear, and other damage. Replace if damaged.
3. Measure thickness of one thick external tooth clutch plate (5). Plate must measure no less than 0.1161 in. (2.9489 mm).
4. Measure thickness of other three external tooth clutch plates (4). Plates must measure no less than 0.0993 in. (2.5222 mm).
5. Measure thickness of four clutch plates (3). Plates must measure no less than 0.1347 in. (3.4214 mm).

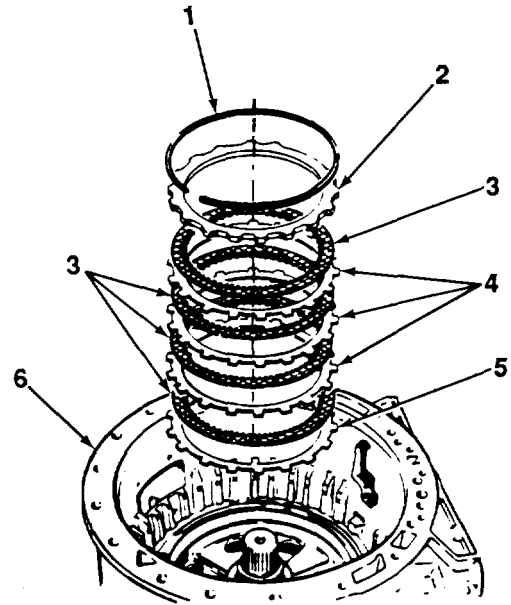

c. INSTALLATION

- 1 Apply thin coat of hydraulic fluid to surface of all metal parts including clutch plates (3) and external tooth clutch plates (4 and 5).
- 2 Install thick external tooth clutch plate (5) first, then install three external tooth clutch plates (4) and four clutch plates (3) into transmission housing (6).
- 3 Install third clutch backing plate (2) and snapping (1) Place gap of snapping at top of transmission housing (6).
- 4 Measure clearance between snapping (1) and third clutch backing plate (2). Clearance must be 0.06-0.12 in. (1.52-3.05 mm).
- 5 If clearance is not within specified limits, replace clutch plates (3) and external tooth clutch plates (4) until proper clearance is obtained. Clearance closer to 0.06 in. (1.52 mm) is preferred.

FOLLOW-ON TASKS:

Install fourth clutch (see paragraph 6-17).

6-19. OUTPUT HOUSING REPLACEMENT.*This Task Covers:*

a. Removal

b. Installation

*Initial Setup:***Equipment Conditions:**

- Third clutch removed (see paragraph 6-18)

Tools/Test Equipment:

- General mechanic's tool kit
- Field automotive shop set
- Lifting bracket

Materials/Parts:

- Grease (Item 10, Appendix B)
- One gasket
- Twenty-four lockwashers

a. REMOVAL

1. With rear of adapter housing (6) facing upward, install lifting bracket to output shaft (2).
2. Remove three screws (3), 21 screws (1), and 24 lockwashers (4) from output housing (7). Discard lockwashers.
3. Attach lifting device to lifting bracket.
4. Lift output housing (7) from adapter housing (6) and move to work area. Remove lifting device and lifting bracket.
5. Remove gasket (5). Discard gasket.

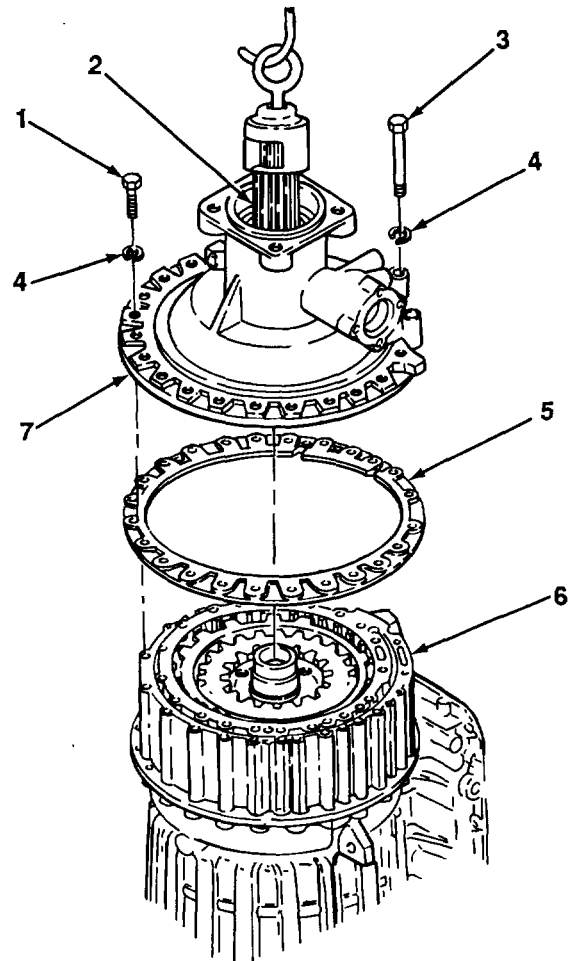

6-19. OUTPUT HOUSING REPLACEMENT (Con't)**b. INSTALLATION**

1. Apply thin coat of grease to surface of new gasket (5).
2. Position gasket (5) on adapter housing (6).
3. Install lifting bracket to output shaft (2).
4. Attach lifting device to lifting bracket.
5. Lift output housing (7) and position on adapter housing (6).
6. Install 24 new lockwashers (4), 21 screws (1), and three screws (3). Torque screws to 67-80 lb.-ft. (91-108 N•m).

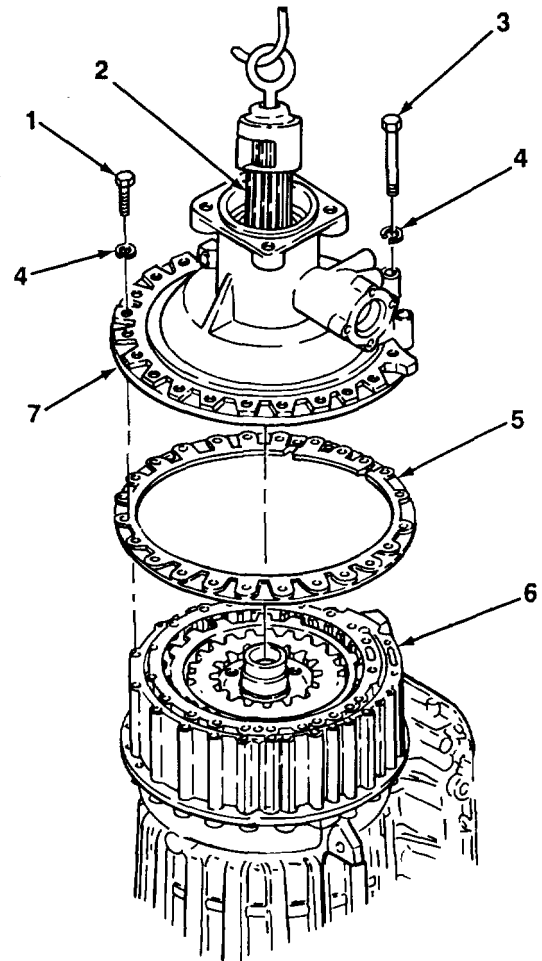
**FOLLOW-ON TASKS:**

- Install third clutch (see paragraph 6-18).

6-20. LOW PLANETARY CARRIER REPLACEMENT.

This Task Covers:

- | | |
|------------|-----------------|
| a. Removal | b. Installation |
|------------|-----------------|

Initial Setup:

Equipment Conditions:

- Output housing removed (see paragraph 6-19)

Tools/Test Equipment:

- General mechanic's tool kit

a. REMOVAL**CAUTION**

Do not attempt to carry low planetary carrier by ball bearing. Ball bearing may not be tight on low planetary carrier.

Remove low planetary carrier (1) from internal gear (2).

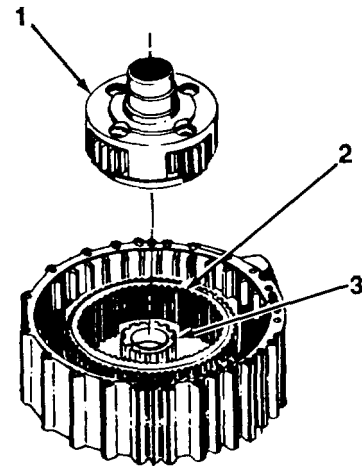
**b. INSTALLATION****NOTE**

For ease in Installation ensure that teeth of four pinion gears mesh with teeth of Internal gear and low planetary sun gearshaft.

Install low planetary carrier (1) into sun gearshaft (3) and internal gear (2).

FOLLOW-ON TASKS:

- Install output housing (see paragraph 6-19).

TA703821

6-21. LOW RING GEAR AND LOW CLUTCH REPLACEMENT.

This Task Covers:

- | | |
|----------------------------|-----------------|
| a. Removal | c. Installation |
| b. Cleaning and Inspection | |
-

Initial Setup:

Equipment Conditions:

- Low planetary carrier removed (see paragraph 6-20)
- Dry cleaning solvent (Item 23, Appendix B)

Materials/Parts:

- Hydraulic fluid (Item 7, Appendix B)

Tools/Test Equipment:

- General mechanic's tool kit

General Safety Instructions:

- Dry cleaning solvent is flammable and must not be used near open flame. Use only in a well-ventilated area.
-

a. REMOVAL**NOTE**

First two clutch plates removed (with clutch disk between) are slightly thicker than others. Note location of thick clutch plates for installation.

1. Remove thick clutch plate (1), clutch disk (2), and low ring gear (3) from adapter housing (4).
2. Remove thick clutch plate (1), five clutch disks (2), and five clutch plates (5).

b. CLEANING AND INSPECTION**WARNING**

Dry cleaning solvent, P-D-680, is toxic and flammable. Always wear protective goggles and gloves, and use only in a well-ventilated area. Avoid contact with skin, eyes, and clothes, and DO NOT breathe vapors. DO NOT use near open flame or excessive heat. The solvent's flash point is 100°F-138°F (38°C-59°C). If you become dizzy while using cleaning solvent, immediately get fresh air and medical help. If solvent contacts eyes, immediately wash your eyes and get medical aid.

1. Clean metal parts, except clutch disks, with dry cleaning solvent.
2. Inspect metal parts for cracks, breaks, wear, and other damage. Replace if damaged.
3. Measure thickness of two thick clutch plates (1). Clutch plates must measure no less than 0.1161 in. (2.9489 mm).
4. Measure thickness of other five clutch plates (5). Clutch plates must measure no less than 0.0993 in. (2.5222 mm).
5. Measure thickness of six clutch disks (2). Clutch disks must measure no less than 0.1347 in. (3.4214 mm).

6-21. LOW RING GEAR AND LOW CLUTCH REPLACEMENT (Con't).**c. INSTALLATION**

1. Apply thin coat of hydraulic fluid to surface of all metal parts including clutch plates (1 and 5) and clutch disks (2).
2. Place low ring gear (3) on work surface with flat side of low ring gear facing downward.
3. Beginning with one clutch disk (2), alternately install five clutch disks and five clutch plates (5) on low ring gear (3).
4. While holding clutch disks (2), clutch plates (5), and low ring gear (3) together as an assembly, turn assembly over and install in adapter housing (4).
5. Install thick clutch plate (1), clutch disk (2), and thick clutch plate (1) into adapter housing (4).

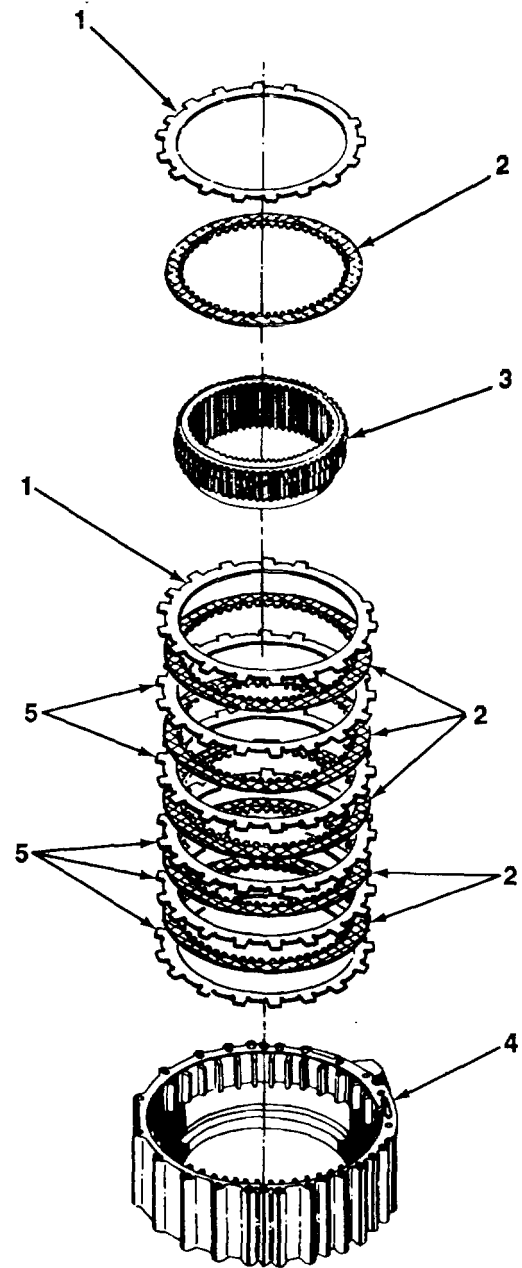
**FOLLOW-ON TASKS:**

- Install low planetary carrier (see paragraph 6-20).

6-22. ADAPTER HOUSING REPLACEMENT.

This Task Covers:

a. Removal

b. Installation

Initial Setup:

Equipment Conditions:

- Low ring gear and low clutch removed (see paragraph 6-21)

Materials/Parts:

- Grease (Item 10, Appendix B)
- One gasket

Tools/Test Equipment:

- General mechanic's tool kit

a. REMOVAL

CAUTION

Use care when removing and handling adapter housing to ensure that first clutch piston inside adapter housing does not fall out.

Remove adapter housing (1) and gasket (2) from transmission housing (3). Discard gasket.

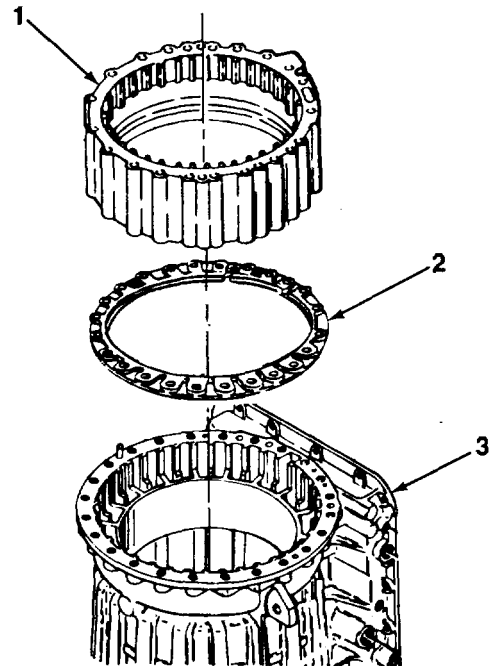

b. INSTALLATION

1. Apply thin coat of grease to surface of new gasket (2).
2. Install new gasket (2) and adapter housing (1) to transmission housing (3).

FOLLOW-ON TASKS:

- Install low ring gear and low clutch (see paragraph 6-21).

6-23. FIRST CLUTCH AND RING GEAR REPLACEMENT.*This Task Covers:*

- | | |
|----------------------------|-----------------|
| a. Removal | c. Installation |
| b. Cleaning and Inspection | |
-

*Initial Setup:***Equipment Conditions:**

- Adapter housing removed (see paragraph 6-22)

Materials/Parts:

- Hydraulic fluid (Item 7, Appendix B)
- Dry cleaning solvent (Item 23, Appendix B)

Tools/Test Equipment:

- General mechanic's tool kit
- Field automotive shop set

General Safety Instructions:

- Dry cleaning solvent is flammable and must not be used near open flame. Use only in a well-ventilated area.
-

a. REMOVAL**NOTE**

First clutch plate removed is slightly thicker than others. Note location of thick clutch

1. Remove one clutch plate (1) and one clutch disk (2) from transmission housing (4).
2. Remove first clutch ring gear (3).

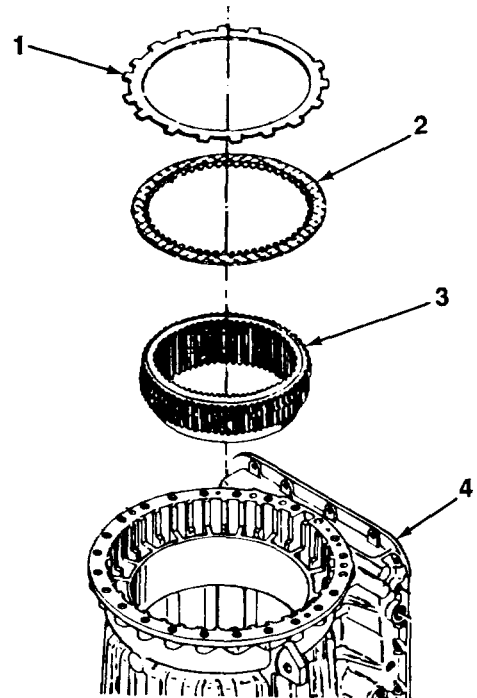

6-23. FIRST CLUTCH AND RING GEAR REI

3. Remove six clutch plates (5) and five clutch disks (2) from transmission housing (4).

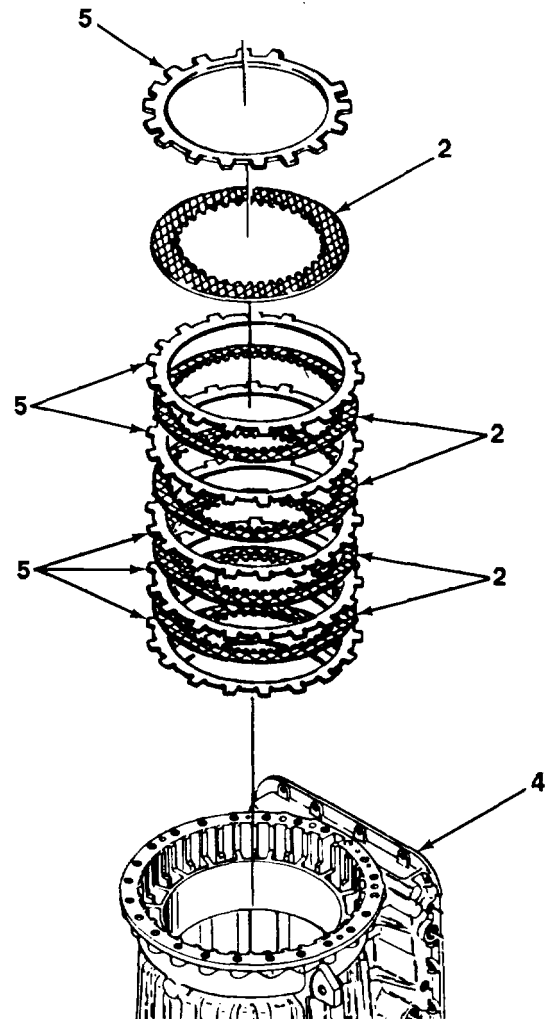
**b. CLEANING AND INSPECTION****WARNING**

Dry cleaning solvent, P-D-680, is toxic and flammable. Always wear protective goggles and gloves, and use only in a well-ventilated area. Avoid contact with skin, eyes, and clothes, and DO NOT breathe vapors. DO NOT use near open flame or excessive heat. The solvent's flash point is 100°F-138°F (38°C-59°C). If you become dizzy while using cleaning solvent, immediately get fresh air and medical help. If solvent contacts eyes, immediately wash your eyes and get medical aid.

1. Clean metal parts, except clutch disks, with dry cleaning solvent.
2. Inspect metal parts for cracks, breaks, wear, and other damage. Replace if damaged.

TA703825

6-23. FIRST CLUTCH AND RING GEAR REPLACEMENT (Con't).

3. Measure thickness of clutch plate (1). Clutch plate must measure no less than 0.1161 in. (2.9489 mm).
4. Measure thickness of six clutch plates (5). Clutch plates must measure no less than 0.0993 in. (2.5222 mm).
5. Measure thickness of six clutch disks (2). Clutch disks must measure no less than 0.1347 in. (3.4214 mm).

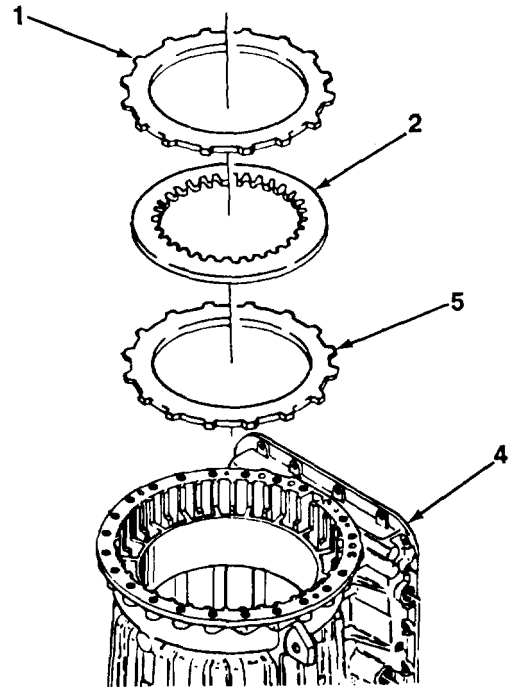
**c. INSTALLATION**

1. Apply thin coat of hydraulic fluid to surface of all metal parts, including clutch plates (1 and 5) and clutch disks (2).
2. Place first clutch ring gear (3) on work surface with short splines facing downward.
3. Beginning with one clutch disk (2) first, alternately install five clutch disks and five clutch plates (5) on first clutch ring gear (3).
4. While holding clutch disks (2), clutch plates (5), and first clutch ring gear (3) together as an assembly, turn assembly over and install in transmission housing (4).

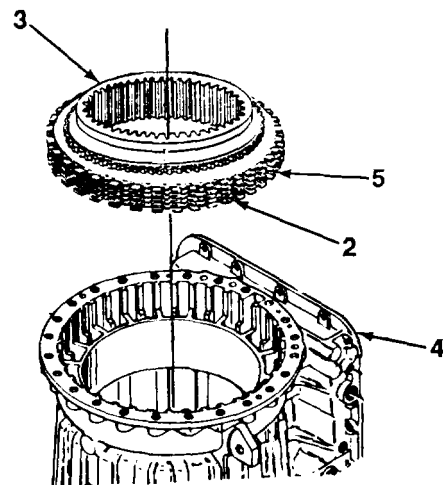

TA703826

6-23. FIRST CLUTCH AND RING GEAR REPLACEMENT (Con't).

5. Install clutch plate (5), clutch disk (2), and clutch plate (1) into transmission housing (4).

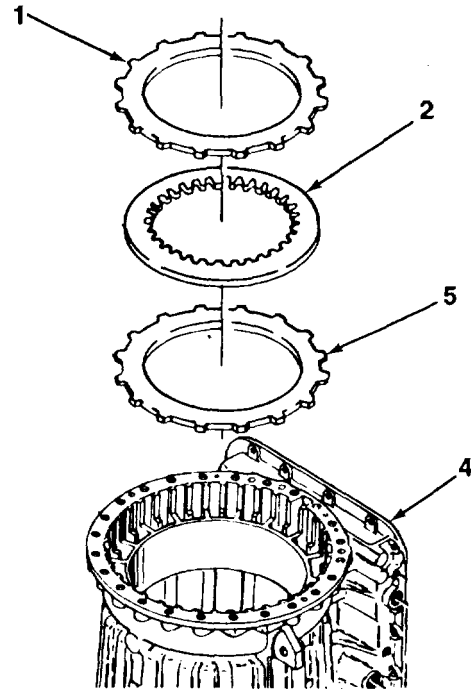
**FOLLOW-ON TASKS:**

- Install adapter housing (see paragraph 6-22).

6-24. CENTER SUPPORT REPLACEMENT.

This Task Covers:

a. Removal

b. Installation

Initial Setup:

Equipment Conditions:

- First clutch and ring gear removed (see paragraph 6-23).
- Center support lifting bracket

Tools/Test Equipment:

- General mechanic's tool kit
 - Center support compressor
-

a. REMOVAL

NOTE

Center support compressor is used to support gear unit as transmission housing is rotated.

1. Position adapter housing (1) on transmission housing (3), and install center support compressor across center of adapter housing.
2. Install center support compressor to adapter housing (1) and transmission housing (3) with two bolts (2).

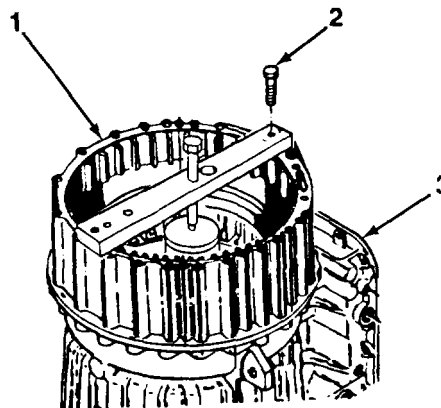

TA703828

6-24. CENTER SUPPORT REPLACEMENT (Co

3. Rotate transmission housing (3) so front of transmission housing is facing upward.
4. Remove center support bolt (6) and center support washer (5) from side of transmission housing (3).

NOTE

Snapping Is one of four color marked snaprings that can be selected for Installation.

5. Remove large snapping (4) from transmission housing (3).

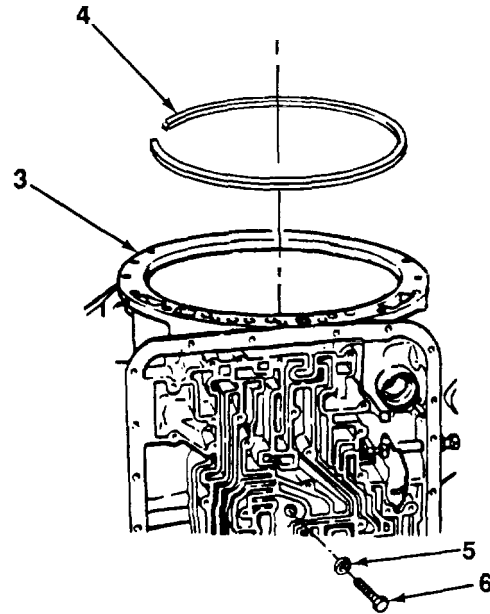
**NOTE**

Center support fits snugly into transmission housing. If center support binds when removing, tap it downward and lift again. Heat transmission housing slightly if necessary.

6. Using center support lifting bracket attached to hub of center support (7), remove center support from transmission housing (3).

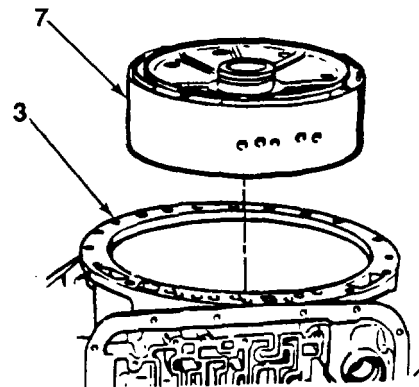

TA703829

6-24. CENTER SUPPORT REPLACEMENT (Con't).

b. INSTALLATION**NOTE**

Ensure that tapped hole in center support is aligned with center support bolt hole in side of transmission housing.

1. Using center support lifting bracket attached to hub of center support (7), install center support into transmission housing (3).
2. Install center support washer (5) and center support bolt (6) to side of transmission housing (3).

NOTE

Snapping is one of four color marked snaprings that can be selected for installation.

3. Install large snapping (4) into transmission housing (3).
4. Rotate transmission housing (3) so rear of transmission housing is facing upward.
5. Remove two bolts (2), center support compressor, and adapter housing (1) from transmission housing (3).

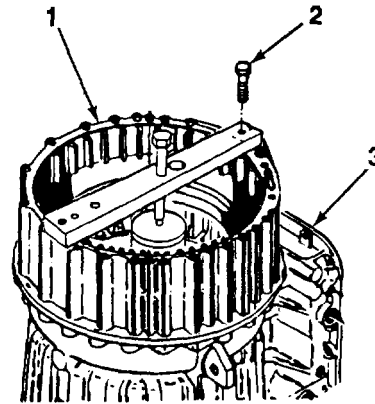
**FOLLOW-ON TASKS:**

- Install first clutch and ring gear (see paragraph 6-23).

TA703830

6-25. GEAR UNIT REPLACEMENT.

This Task Covers:

- a. Removal b. Installation
-

Initial Setup:

Equipment Conditions:

- Center support removed (see paragraph 6-24).

Tools/Equipment

- General mechanic's tool kit
 - Field automotive shop set
 - Main shaft lifting bracket
-

a. REMOVAL

1. Install lifting bracket to main shaft (1) of gear unit assembly (2).
2. Attach lifting device to lifting bracket.
3. Remove gear unit assembly (2) from transmission housing (3) and move to work surface. Remove lifting device and lifting bracket.

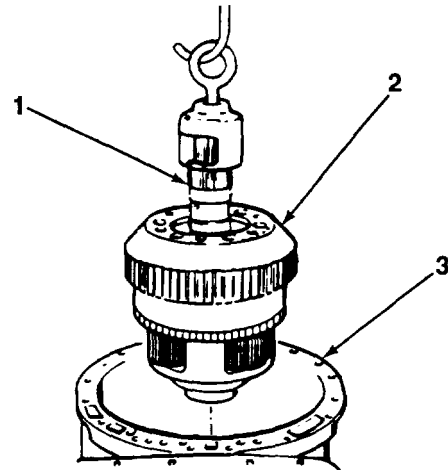

4. Rotate transmission housing (3) so rear of transmission housing is facing upward.
5. Remove two bolts (5) through center support compressor. Remove center support compressor and adapter housing (4) from transmission housing (3).

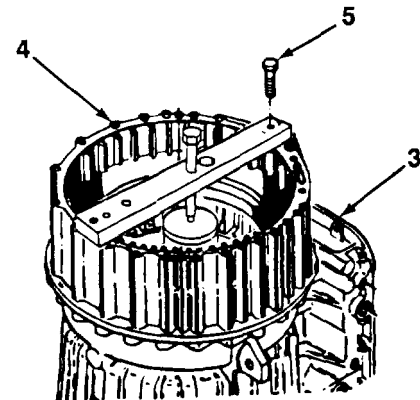

TA703831

6-25. GEAR UNIT REPLACEMENT (Con't).

b. INSTALLATION

1. Rotate transmission housing (3) so rear of transmission housing is facing upward.
2. Position adapter housing (4) to transmission housing (3) temporarily and install center support compressor across center of adapter housing.
3. Install two bolts (5) of center support compressor through adapter housing (4) and into transmission housing (3).
4. Rotate transmission housing (3) so front of transmission housing is facing up. Install lifting bracket to main shaft (1) of gear unit assembly (2).
5. Attach lifting device to lifting bracket.
6. Install gear unit assembly (2) in transmission housing (3).
7. Remove lifting device and lifting bracket.

FOLLOW-ON TASKS:

- install center support (see paragraph 6-24).

6-26. SECOND CLUTCH REPLACEMENT.*This Task Covers:*

- | | |
|----------------------------|-----------------|
| a. Removal | c. Installation |
| b. Cleaning and Inspection | |

*Initial Setup:***Equipment Conditions:**

- Gear unit removed (see paragraph 6-25).

Tools/Test Equipment:

- General mechanic's tool kit
- Field automotive shop set

Materials/Parts:

- Hydraulic fluid (Item 7, Appendix B)
- Dry cleaning solvent (Item 23, Appendix B)

General Safety Instructions:

- Dry cleaning solvent is flammable and must not be used near open flame. Use only in a well-ventilated area.

a. REMOVAL

1. Rotate transmission housing (3) so front of transmission housing is facing upward.
2. Remove large snapping (1) from transmission housing (3).

NOTE

First clutch plate removed is slightly thicker than others. Note location of thick clutch plate for installation.

3. Remove clutch plate (2).

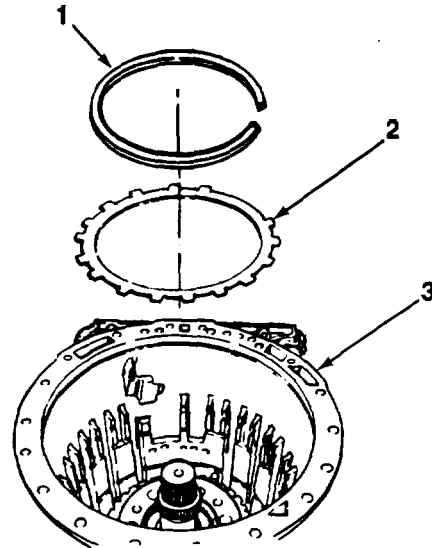

TA703832

6-26. SECOND CLUTCH REPLACEMENT (Con't).

4. Remove six clutch disks (4) and six clutch plates (5) from transmission housing (3).

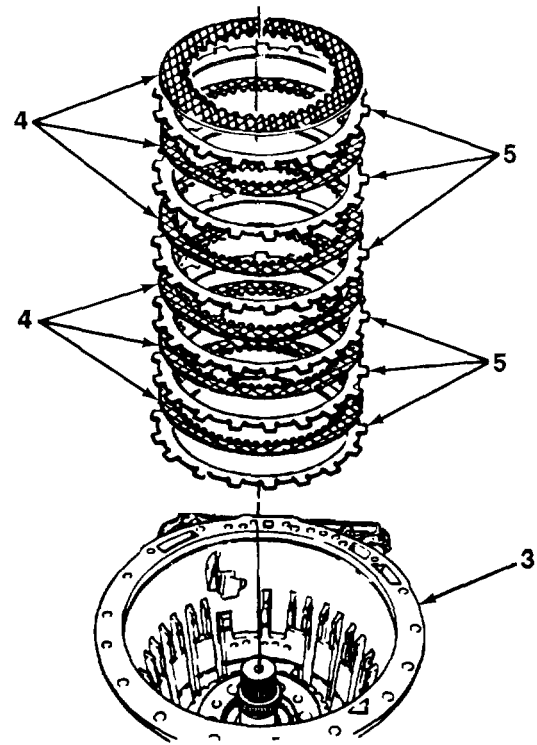
**b. CLEANING AND INSPECTION****WARNING**

Dry cleaning solvent, PD680, is toxic and flammable. Always wear protective goggles and gloves, and use only in a well-ventilated area. Avoid contact with skin, eyes, and clothes, and DO NOT breathe vapors. DO NOT use near open flame or excessive heat. The solvent's flash point is 1000F/1380F (38°C/590C). If you become dizzy while using cleaning solvent, immediately get fresh air and medical help. If solvent contacts eyes, immediately wash your eyes and get medical aid.

1. Clean metal parts, except clutch disks, with dry cleaning solvent.
2. Inspect metal parts for cracks, breaks, wear, and other damage. Replace if damaged.

TA703833

6-26. SECOND CLUTCH REPLACEMENT (Con't)

3. Measure thickness of clutch plate (2). Clutch plate must measure no less than 0.1161 in. (2.9489 mm).
4. Measure thickness of six clutch plates (5). Clutch plates must measure no less than 0.0993 in. (2.5mm).
5. Measure thickness of six clutch disks (4). Clutch disks must measure no less than 0.1347 in. (3.4214 mm).

c. INSTALLATION I

1. Apply thin coat of hydraulic fluid to surface of metal parts, including clutch plates (2 and 5) and clutch disks (4).

NOTE**Install thick clutch plate last.**

2. Beginning with one clutch plate (5), alternately install six clutch plates and six clutch disks (4) into transmission housing (3).
3. Install clutch plate (2).
4. Install large snapping (1).

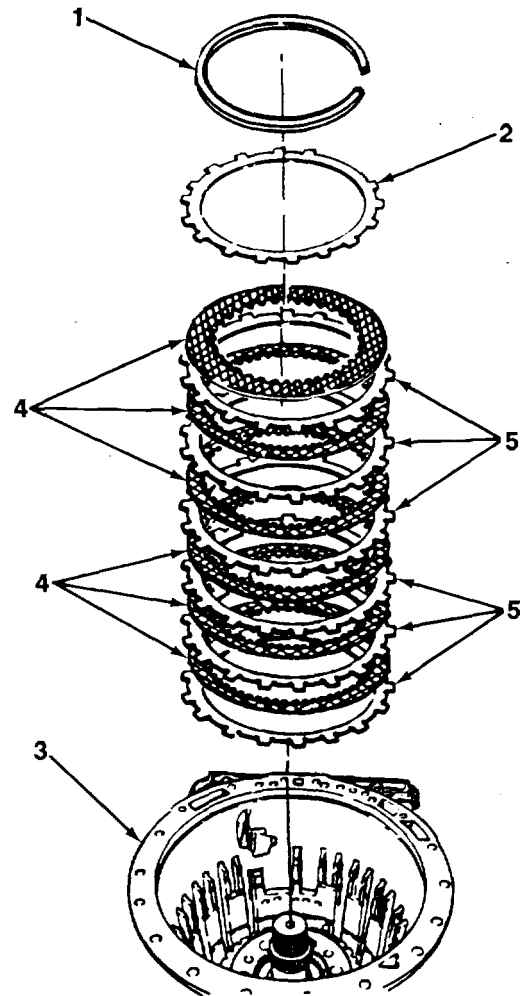
**FOLLOW-ON TASKS:**

- Install gear unit (see paragraph 6-25).

TA703834

6-27. TRANSMISSION HOUSING REPAIR

This Task Covers:

- a. Disassembly
- b. Cleaning and Inspection
- c. Assembly

Initial Setup:

Equipment Conditions:

- Second clutch removed (see paragraph 6-26).

Tools/Test Equipment:

- General mechanic's tool kit
- Field automotive shop set
- Manual shaft oil seal installer

Materials/Parts:

- Hydraulic fluid (Item 7, Appendix B)
- Sealing compound (Item 19, Appendix B)
- Dry cleaning solvent (Item 23, Appendix B)
- One locknut
- One oil seal

General Safety Instructions:

- Dry cleaning solvent is flammable and must not be used near open flame. Use only in a well-ventilated area.
-

a. DISASSEMBLY

1. Remove breather (2) from transmission housing (1).
2. Remove plug (4).
3. Remove modulator rod (3).

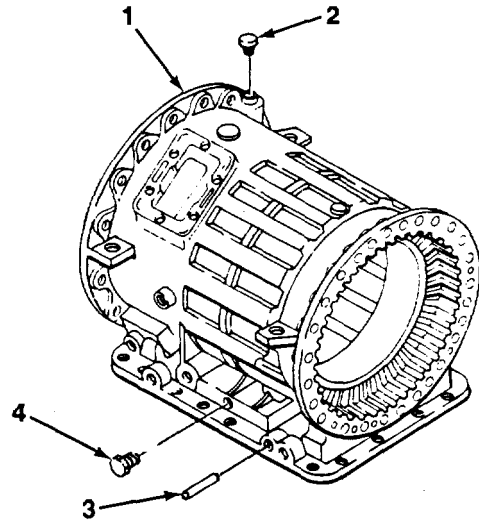

TA703835

6-27. TRANSMISSION HOUSING REPAIR (Con't)

4. Turn transmission housing (1) over and remove retainer pin (5) and locknut (6) from manual selector shaft (9). Discard locknut.
5. Remove manual selector shaft (9) and inside detent lever (7).
6. Using manual shaft oil seal installer, remove selector shaft oil seal (8). Discard selector shaft oil seal.

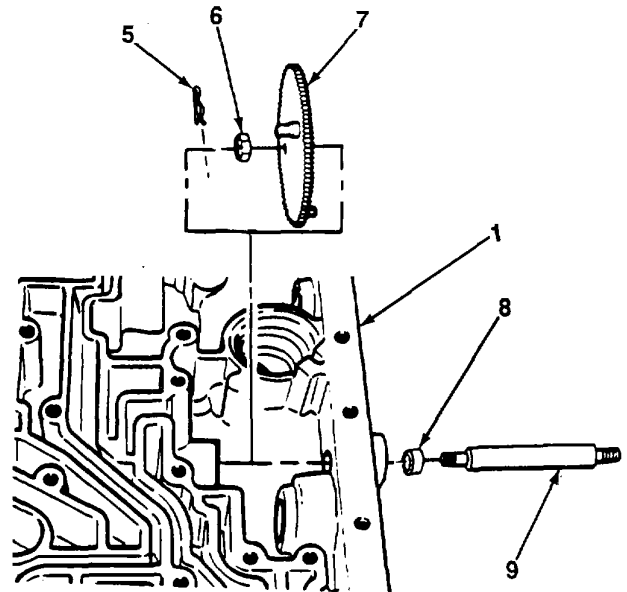
**b. CLEANING AND INSPECTION I****WARNING**

Dry cleaning solvent, PD680, is toxic and flammable. Always wear protective goggles and gloves, and use only in a well-ventilated area. Avoid contact with skin, eyes, and clothes, and DO NOT breathe vapors. DO NOT use near open flame or excessive heat. The solvent's flash point is 100°F/38°C (380C/590C). If you become dizzy while using cleaning solvent, immediately get fresh air and medical help. If solvent contacts eyes, immediately wash your eyes and get medical aid.

1. Clean metal parts with dry cleaning solvent.
2. Inspect metal parts for cracks, breaks, wear, and other damage. Replace if damaged.
3. Inspect plug for damage. Replace if damaged.

TA703836

6-27. TRANSMISSION HOUSING REPAIR (Con't).

4. Inspect four mounting studs (10) for damage. Replace if damaged.

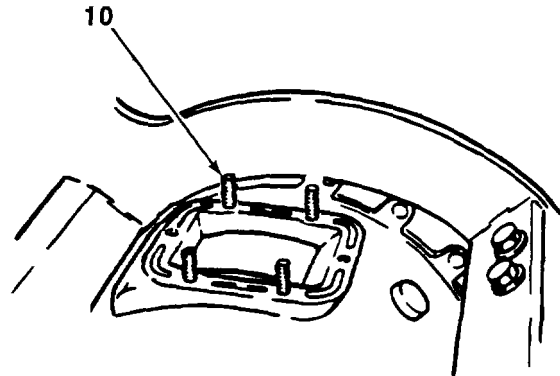

1. Apply thin coat of sealing compound to outer surface of new selector shaft oil seal (8).
2. Using manual shaft oil seal installer, install selector shaft oil seal (8) in transmission housing (1) with lip of seal facing inward.
3. Apply thin coat of hydraulic fluid to surface of manual selector shaft (9), and install manual selector shaft and inside detent lever (7) with new locknut (6) and retainer pin (5). Torque locknut to 1520 lb.ft. (2027 N.m).

NOTE

Ensure that pin of Inside detent lever faces inward toward center of transmission housing.

4. Apply thin coat of hydraulic fluid to surface of modulator rod (3) and install modulator rod to transmission housing (1).
5. Install plug (4).
6. Install breather (2).

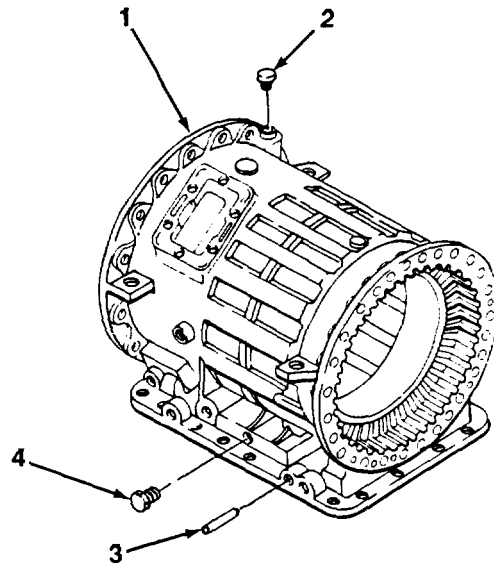
**FOLLOW-ON TASKS:**

TA703837

- Install second clutch (see paragraph 6-26).

6-28. OIL PUMP REPAIR.

This Task Covers:

- a. Disassembly
- b. Cleaning and Inspection
- c. Assembly

Initial Setup:

Equipment Conditions:

- Oil pump removed (see paragraph 6-15).

Tools/Test Equipment:

- General mechanic's tool kit
- Field automotive shop set

Materials/Parts:

- Hydraulic fluid (Item 7, Appendix B)
- Dry cleaning solvent (Item 23, Appendix B)
- One oil seal

General Safety Instructions:

- Dry cleaning solvent is flammable and must not be used near open flame. Use only in a well-ventilated area.
-

a. DISASSEMBLY

1. Remove screw (1) and oil pump cover (2).
2. Remove drive gear (3) and driven gear (assembly from pin (4)).
3. Remove oil seal (6) from oil pump body (5) using puller. Discard oil seal.

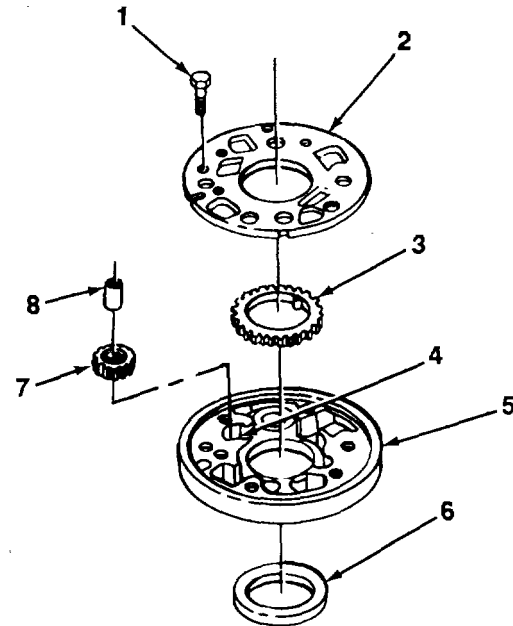

TA703838

6-28. OIL PUMP REPAIR (Con't).

b. CLEANING AND INSPECTION**WARNING**

Dry cleaning solvent, PD680, is toxic and flammable. Always wear protective goggles and gloves, and use only in a well-ventilated area. Avoid contact with skin, eyes, and clothes, and DO NOT breathe vapors. DO NOT use near open flame or excessive heat. The solvent's flash point is 100°F/138°F (38°C/59°C). If you become dizzy while using cleaning solvent, immediately get fresh air and medical help. If solvent contacts eyes, immediately wash your eyes and get medical aid.

1. Clean metal parts with dry cleaning solvent.
2. Inspect metal parts for cracks, breaks, wear, or other damage. Replace if damaged.
3. Inspect drive gear and driven gear clearance as follows:
 - (a) With drive gear, driven gear, oil pump cover, and screw installed to oil pump body, inspect clearance between drive gear and oil pump cover with feeler gage. Clearance should be no more than 0.006 in. (0.152 mm).
 - (b) Inspect clearance between driven gear and oil pump cover. Clearance should be no more than 0.006 in. (0.152 mm).
4. Inspect bearing (8) in driven gear (7) for wear or damage. If bearing is damaged, press out bearing.
5. Apply thin coat of hydraulic fluid to surface of metal parts, bearing, and new oil seal.
6. Inspect pin (4) for damage. Replace if damaged.

c. ASSEMBLY**NOTE**

When installing oil seal, ensure that lip of oil seal faces downward.

1. Press new oil seal (6) flush with top surface of oil pump body (5).
2. If removed, press new bearing (8) into driven gear (7) until centered in driven gear.
3. Install driven gear (7) assembly and drive gear (3) into oil pump body (5).
4. Install oil pump cover (2) to oil pump body (5) with screw (1).

FOLLOW-ON TASKS:

- Install oil pump (see paragraph 6-15).

6-29. FRONT SUPPORT REPAIR.*This Task Covers:*

- | | |
|----------------------------|-------------|
| a. Disassembly | c. Assembly |
| b. Cleaning and Inspection | |

*Initial Setup:***Equipment Conditions:**

- Converter housing removed (see paragraph 6-15).

Tools/Test Equipment:

- General mechanic's tool kit
- Field automotive shop set
- Bearing installer
- Handle
- Spring compressor

a. DISASSEMBLY**Materials/Parts:**

- Hydraulic fluid (Item 7, Appendix B)
- Dry cleaning solvent (Item 23, Appendix B)
- Two preformed packings

General Safety Instructions:

- Dry cleaning solvent is flammable and must not be used near open flame. Use only in a well-ventilated area.

NOTE

Keep parts of each of three valves separate to avoid mixing parts.

1. Using spring compressor, press inward on washer (6) and remove snapping (7).
2. Remove spring compressor, washer (6), valve stop (5), spring (4), and main pressure regulator (3) from front support (1).
3. Remove preformed packing (2) from main pressure regulator (3). Discard preformed packing.

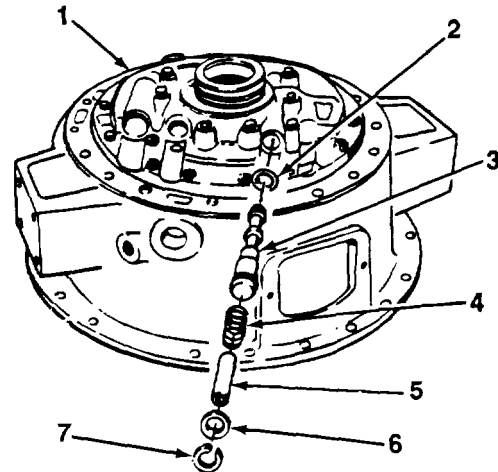

6-29. FRONT SUPPORT REPAIR (Con't).

4. Using spring compressor, press inward on washer (11) and remove retaining ring (12).
5. Remove spring compressor, washer (11), valve stop (10), spring (9), and directional control slide (8) from front support (1).

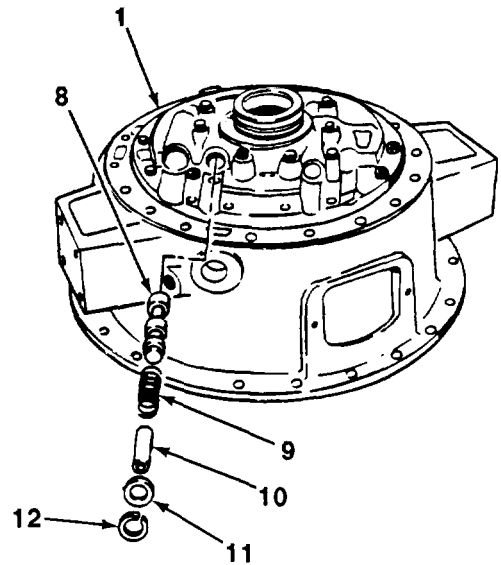

NOTE

Spring compressor is not required to remove valve support assembly

6. Press Inward on valve support assembly (17) and remove retaining ring (18), valve support assembly, valve seat (15), converter bypass valve (14) and spring (13) from front support (1).
7. Remove preformed packing (16) from valve support assembly (17). Discard preformed packing.

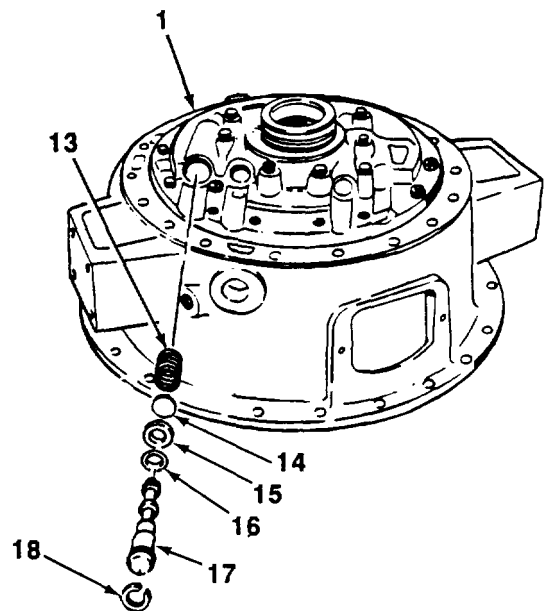

TA703840

6-29. FRONT SUPPORT REPAIR (Con't).

b. CLEANING AND INSPECTION I**WARNING**

Dry cleaning solvent, PD680, is toxic and flammable. Always wear protective goggles and gloves, and use only in a well-ventilated area. Avoid contact with skin, eyes, and clothes, and DO NOT breathe vapors. DO NOT use near open flame or excessive heat. The solvent's flash point is 100°F/138°F (38°C/59°C). If you become dizzy while using cleaning solvent, immediately get fresh air and medical help. If solvent contacts eyes, immediately wash your eyes and get medical aid.

1. Clean metal parts with dry cleaning solvent.

NOTE

Front support and ground sleeve are available only as a unit. Do not attempt to separate. If either is damaged, replace as an assembly.

2. Inspect metal parts for cracks, breaks, wear, or other damage. Replace if damaged.
3. Inspect bearing (19) in front support (1) for wear or damage. If damaged, remove bearing.
4. Apply thin coat of hydraulic fluid to surface of all parts.

c. ASSEMBLY

1. If removed, press new bearing (19) into front support (1) using bearing installer and handle.

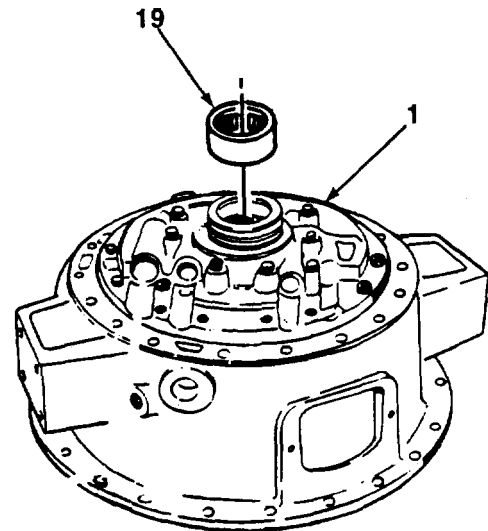

TA703841

6-29. FRONT SUPPORT REPAIR (Con't).

- 2. Install new preformed packing (16) on valve support assembly (17).
- 3. Install spring (13), converter bypass valve (14), valve seat (15), and valve support assembly (17) into front support (1).
- 4. Press inward on valve support assembly (17) and install retaining ring (18).

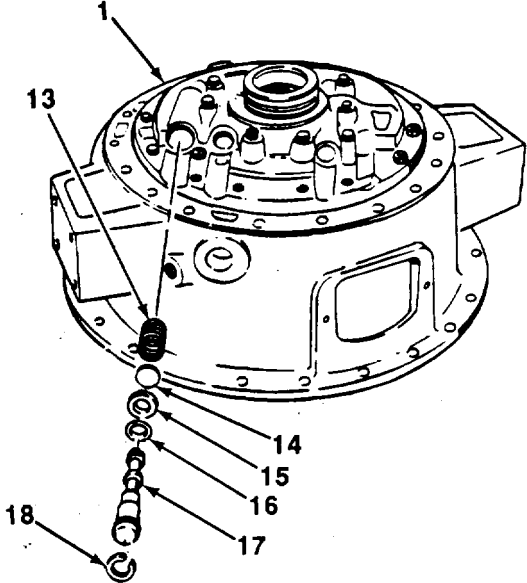

- 5. Install directional control slide (8), spring (9), valve stop (10), and washer (11) into front support (1).
- 6. Using spring compressor, press inward on washer (11) and install retaining ring (12). Remove spring compressor.

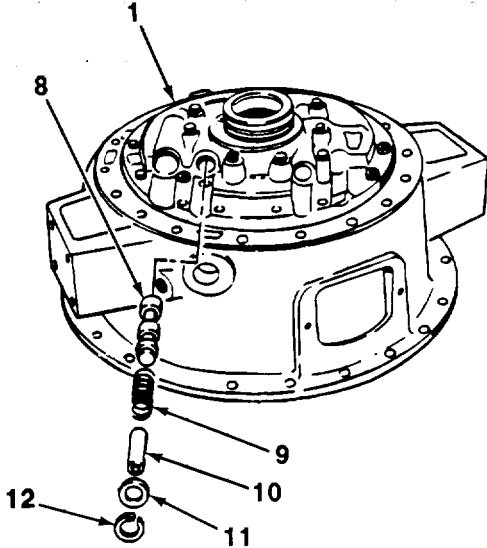

TA703842

6-29. FRONT SUPPORT REPAIR (Con't).

7. Install new preformed packing (2) on main pressure regulator (3).
8. Install main pressure regulator (3), spring (4), valve stop (5), and washer (6) into front support (1).
9. Using spring compressor, press inward on washer (6) and install snapping (7). Remove spring compressor.

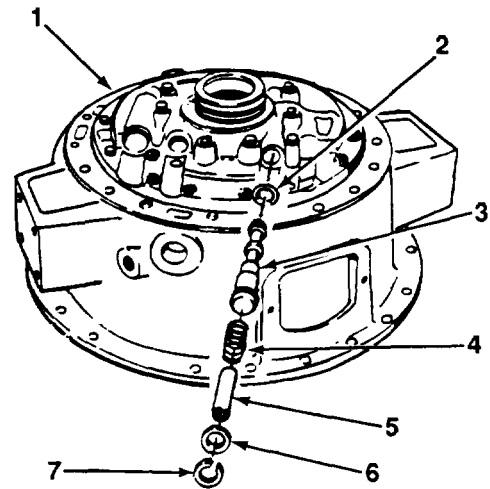
**FOLLOW-ON TASKS:**

- Install converter housing (see paragraph 6-15).

TA703843

6-30. FORWARD CLUTCH REPAIR.

This Task Covers:

- a. Disassembly
- b. Cleaning and Inspection

c. Assembly

Initial Setup:

Equipment Conditions:

- Input shaft and forward clutch removed (see paragraph 6-16).

Tools/Test Equipment:

- General mechanic's tool kit
- Field automotive shop set
- Collector ring staker
- Forward and fourth clutch spring compressor

Materials/Parts:

- Loctite adhesive (tem 1, Appendix B)
- Hydraulic fluid (Item 7, Appendix B)
- Grease (Item 10, Appendix B)
- Dry cleaning solvent (Item 23, Appendix B)
- Three seal rings
- Ten shim stock, 0.02 X 3/32 X 3 in. (0.51 x 2.38 x 76 mm)

General Safety Instructions:

- Dry cleaning solvent is flammable and must not be used near open flame. Use only in a well-ventilated area.
-

a. DISASSEMBLY

1. Remove retaining ring (1) and forward clutch driving hub (2) from hub (3).

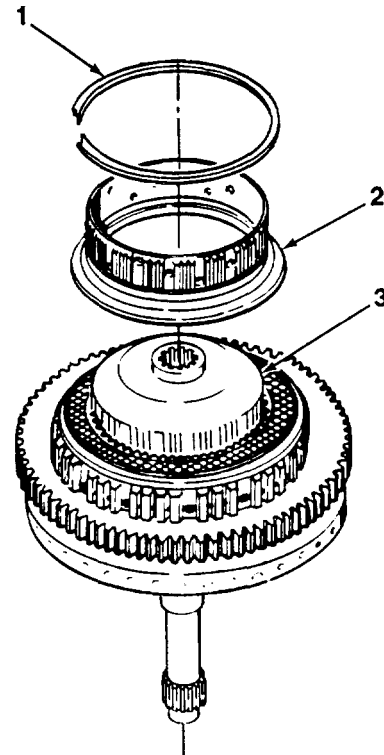

TA703844

6-30. FORWARD CLUTCH REPAIR (Con't).

2. Remove hub (3), bearing ring (6), thrust bearing (5), and bearing race (4) from housing (7).

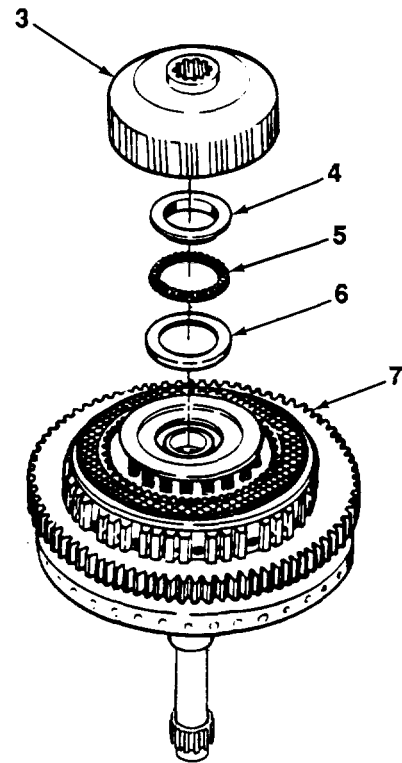

TA703845

6-30. FORWARD CLUTCH REPAIR (Con't).

3. Remove five clutch disks (8) and five external tooth clutch disks (9) from housing (7).

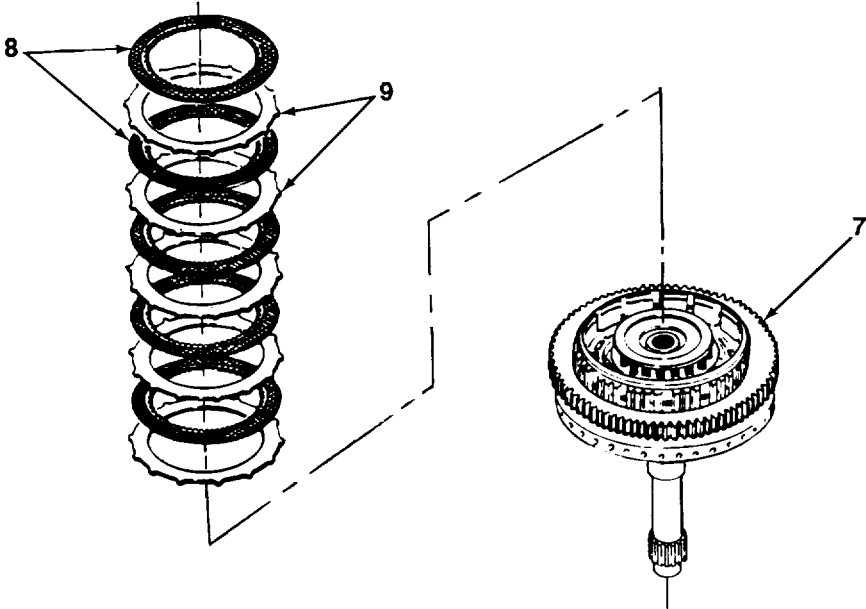

- 4. Using spring compressor, press downward on spring retainer (11) and remove snapping (10).
- 5. Remove spring compressor, spring retainer (11), and 20 springs (12) from forward clutch piston (13).

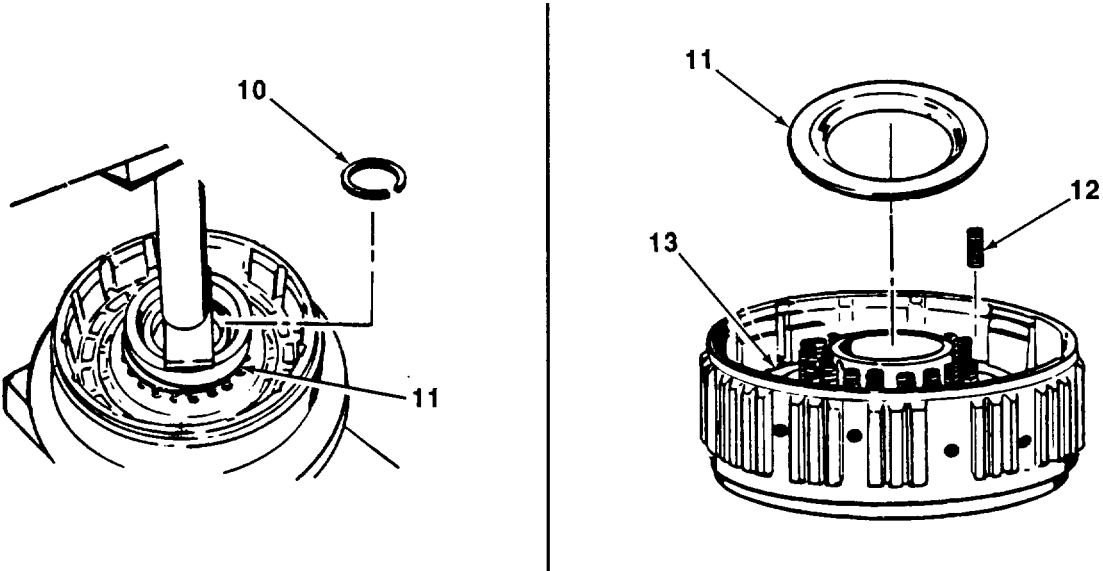

6-30. FORWARD CLUTCH REPAIR (Con't).**NOTE**

Forward clutch piston is marked A, B, or C. If with piston having same marking.

6. Remove forward clutch piston (13) from housing (7).
7. Remove seal rings (14 and 15) from forward clutch piston (13). Discard seal rings.
8. Remove seal ring (16) from inside housing (7). Discard seal ring.

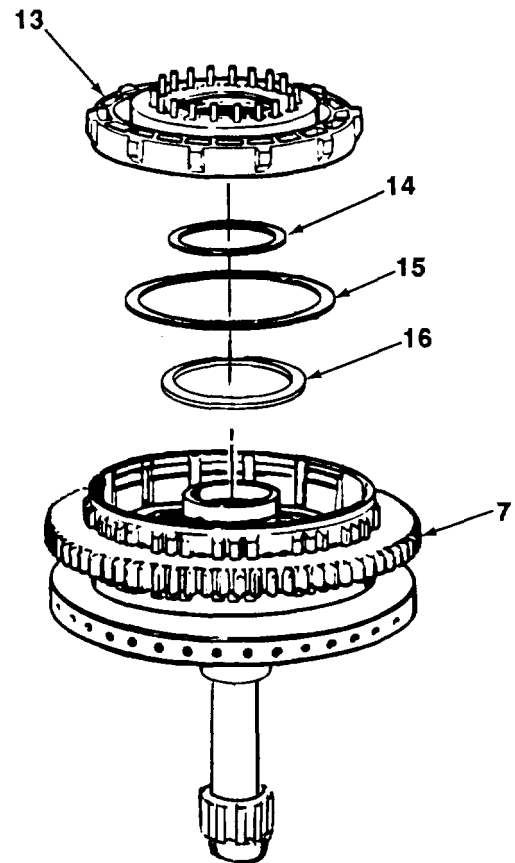

TA703847

6-30. FORWARD CLUTCH REPAIR (Con't).**NOTE**

Perform steps 9 through 13 to remove PTO gear and snapping from forward clutch housing.

9. Locate gap (18) of snapping (17).
10. Push snapping (17) down into groove in housing (7) and insert a shim stock between tooth of PTO gear (19) and outside diameter of snapping.
11. Repeat step 10 around outside diameter of snapping (17), about every 3 in. (7.6 cm), to hold snapping into housing (7).

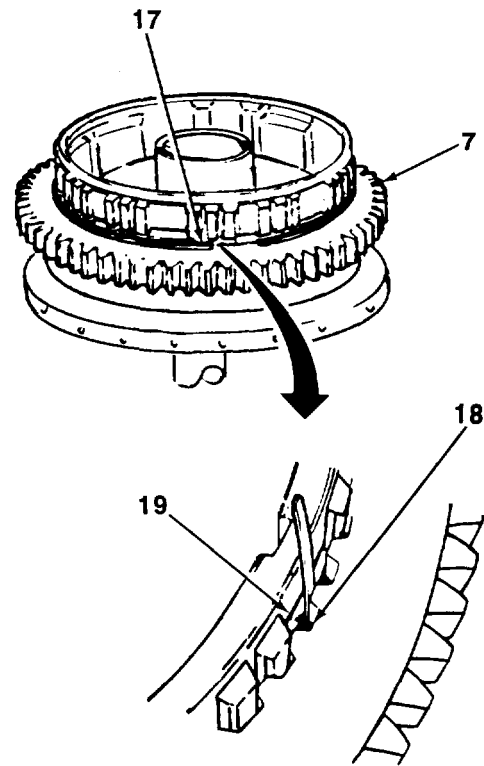

12. Remove PTO gear (19) from housing (7).
13. Remove snapping (17).

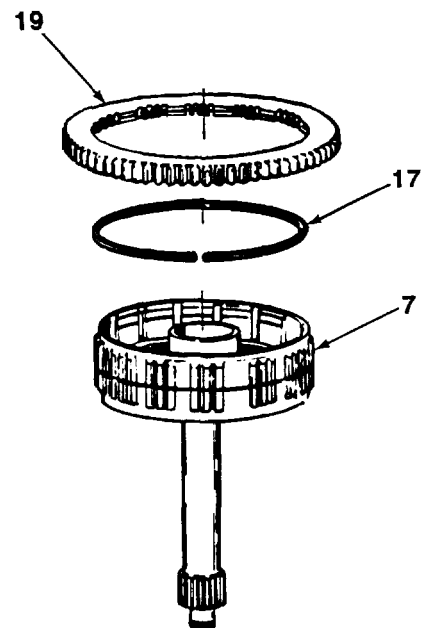

TA703848

6-30. FORWARD CLUTCH REPAIR (Con't).

NOTE

Perform step 14 only if collector ring is damaged.

- 14. With input shaft (21) facing upward, support collector ring (20) and press input shaft and housing (7) assembly downward to remove collector ring from housing.

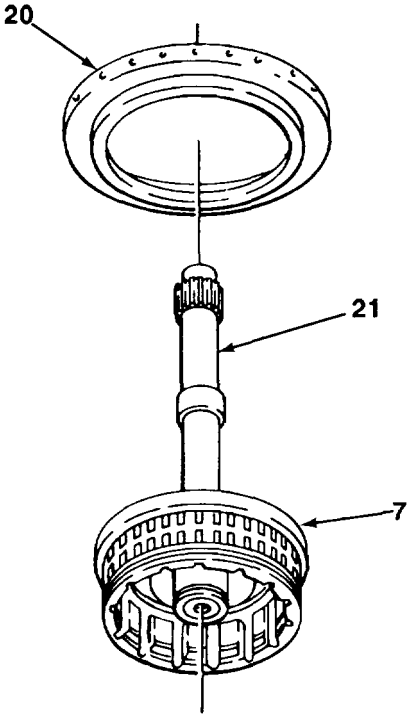

b. CLEANING AND INSPECTOR

WARNING

Dry cleaning solvent, PD680, is toxic and flammable. Always wear protective goggles and gloves, and use only in a well-ventilated area. Avoid contact with skin, eyes, and clothes, and DO NOT breathe vapors. DO NOT use near open flame or excessive heat. The solvent's flash point is 100°F/138°F (38°C/59°C). If you become dizzy while using cleaning solvent, immediately get fresh air and medical help. If solvent contacts eyes, immediately wash your eyes and get medical aid.

- 1. Clean metal parts, except clutch disks, with dry cleaning solvent.
- 2. Inspect metal parts for cracks, breaks, wear, or other damage. Replace if damaged.
- 3. Inspect bearing race, and bearing ring for wear or damage. Replace if damaged.
- 4. Inspect PTO gear for chipped or broken teeth. Replace if damaged.
- 5. Inspect for broken or deformed springs. Springs must meet following requirements:
 - (a) Length without load:.....1.25 in. (3.18 cm).
 - (b) Length with load of 17.9-18.9 lb (79.6-84 N):0.88 in. (22.35 mm).

TA703849

6-30. FORWARD CLUTCH REPAIR (Con't).

6. Measure thickness of each of five clutch disks. Disks must measure no less than 0.090 in. (2.29 mm).
7. Measure thickness of each of five external tooth clutch disks. Disks must measure no less than 0.0993 in.
8. Check four ball bearings (22) for damage by applying a load against ball bearing in the direction of housing (7). Ball bearings must withstand at least 30 lb (133.45 N). Replace only if necessary.

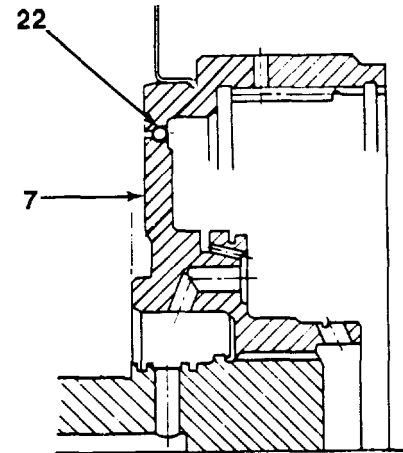
**c. ASSEMBLY****NOTE**

Perform steps 3 through 5 to install new collector ring to forward clutch housing.

1. Apply adhesive to surface of housing (7) to be in contact with collector ring (20).
2. Press new collector ring (20) on housing (7).
3. Using staker (23) and hammer, evenly bend edge of collector ring (20) down into groove of housing (7). Continue bending until edge of collector ring is fully installed in groove of housing.

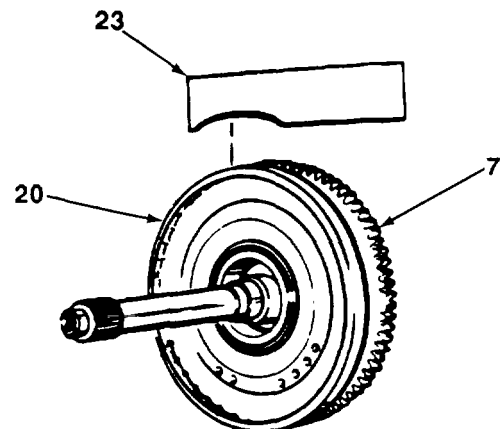

TA703850

6-30. FORWARD CLUTCH REPAIR (Con't).

4. Install snapping (17) in outer groove of housing (7).

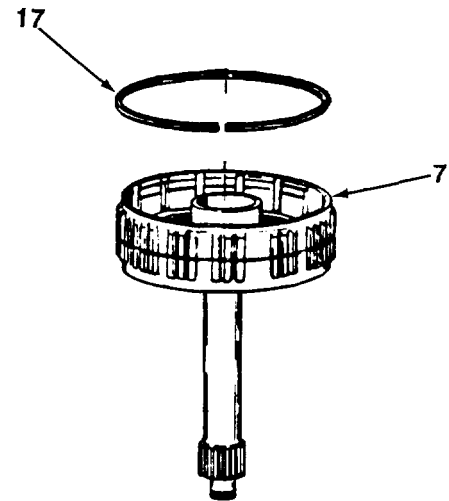

5. With input shaft (21) facing downward, install PTO gear (19), chamfered side up, until snapping (17) engages groove of PTO gear.

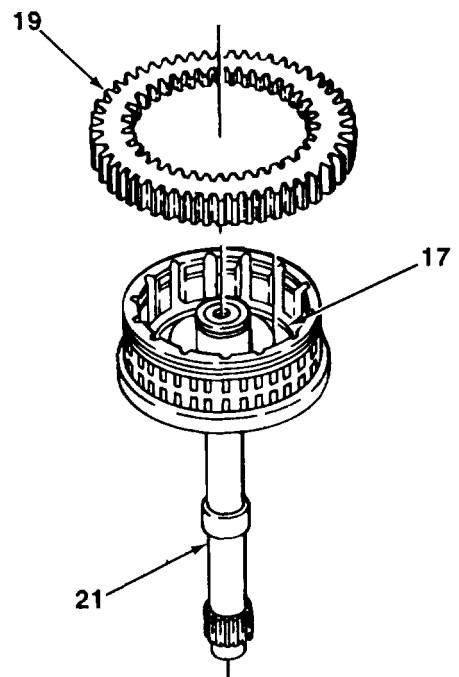

TA703851

6-30. FORWARD CLUTCH REPAIR (Con't).

- 6. With spring pins of forward clutch piston (13) facing downward, apply a thin coat of grease to surface of new seal rings (14 and 15). Install seal rings to forward clutch piston with lips of both seal rings facing upward.

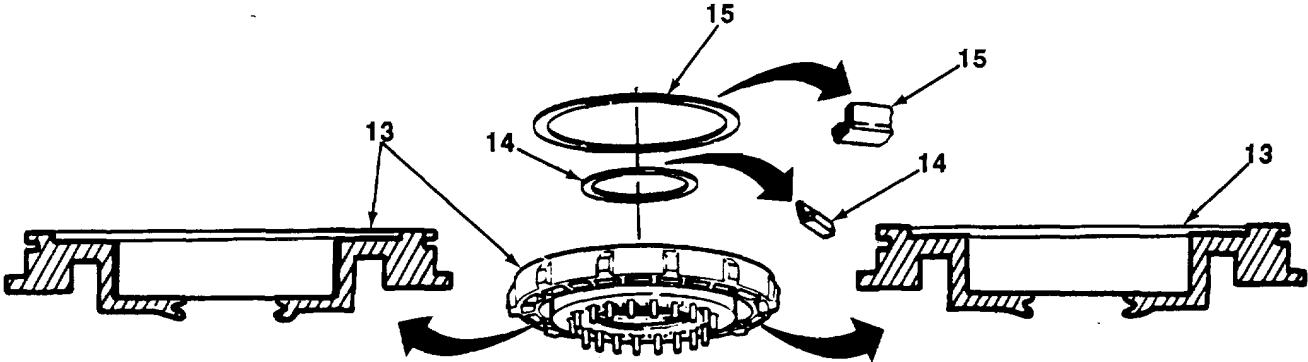

- 7. Apply thin coat of grease to new seal ring (16). Install seal ring inside of housing (7) with lip of seal ring facing upward.
- 8. Install forward clutch piston (13) into housing (7).

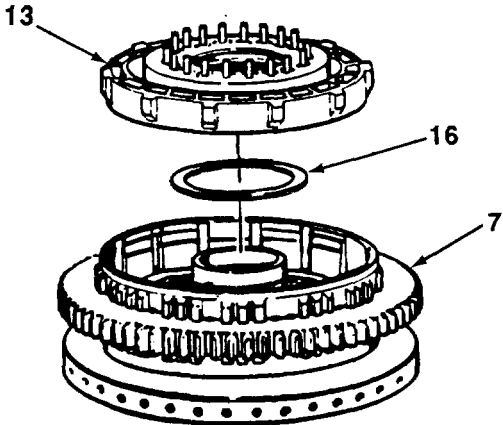

TA703852

6-30. FORWARD CLUTCH REPAIR (Con't).

9. Beginning with one external tooth clutch disk (9), alternately install five external tooth clutch disks and five clutch disks (8) into housing (7).

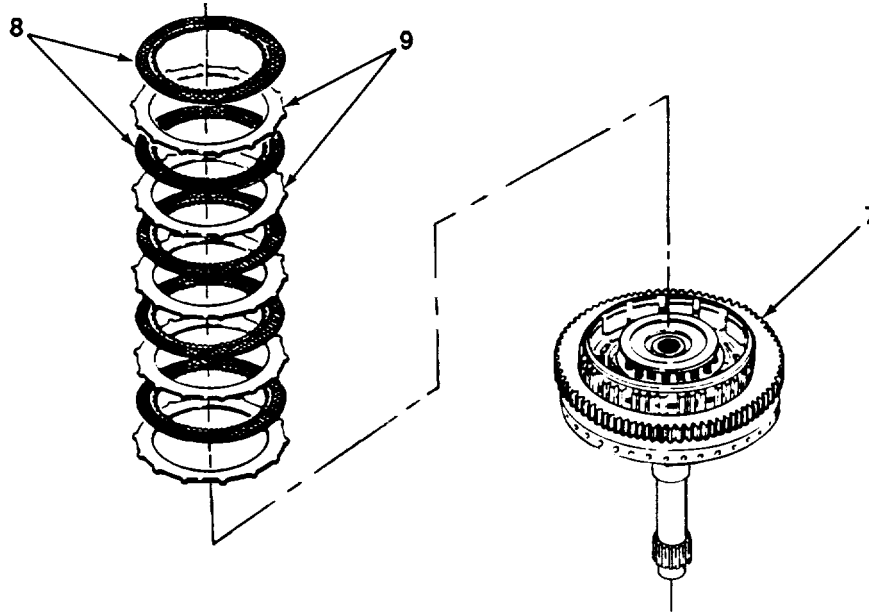

10. Install forward clutch driving hub (2) and retaining ring (1) into housing (7).

11. While lifting forward clutch driving hub (2) against retaining ring (1), measure clearance between top external tooth clutch disk (9) and forward clutch driving hub. Clearance must be 0.080-0.120 in. (2.048 mm).

12. If clearance is not within specified limits, replace clutch disks (8) and external tooth clutch disks (9) until proper clearance is obtained. Clearance closer to 0.080 in. (2.032 mm) is preferred.

13. Remove retaining ring (1), forward clutch driving hub (2), clutch disks (8), and external tooth clutch disks (9).

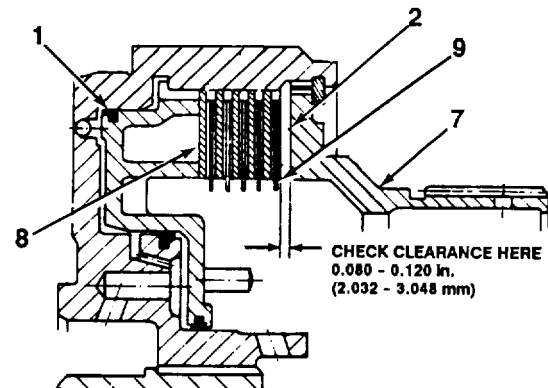

6-30. FORWARD CLUTCH REPAIR (Con't).

14. Install 20 springs (12) and spring retainer (11) to forward clutch piston (13).

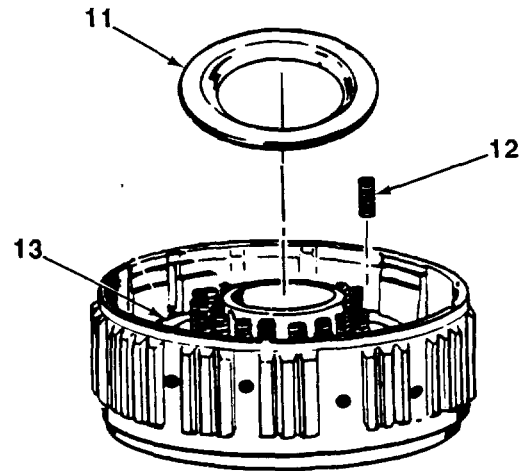

15. Using spring compressor, press spring retainer (11) downward just enough to install snapping (10). Remove spring compressor.

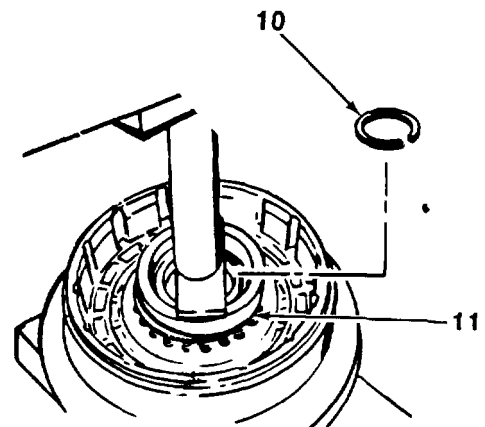

TA703854

6-30. FORWARD CLUTCH REPAIR (Con't).

16. Install bearing race (4), thrust bearing (5), bearing ring (6), and hub (3) on housing (7).

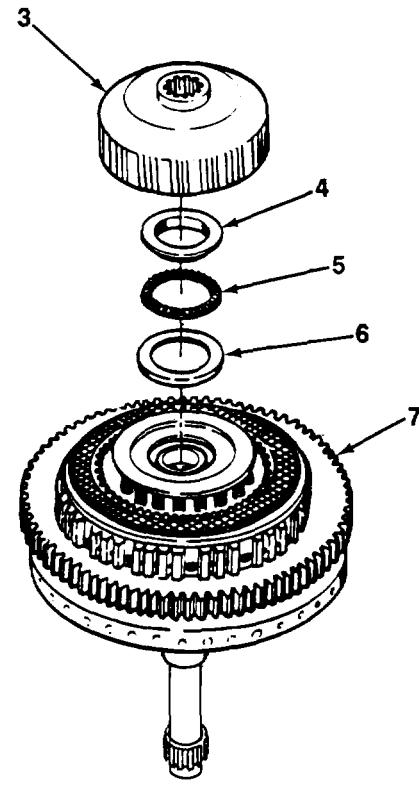

17. Beginning with one external tooth clutch disk (9), alternately Install five external tooth clutch disks and five clutch disks (8) into housing (7).

TA703855

6-30. FORWARD CLUTCH REPAIR (Con't).

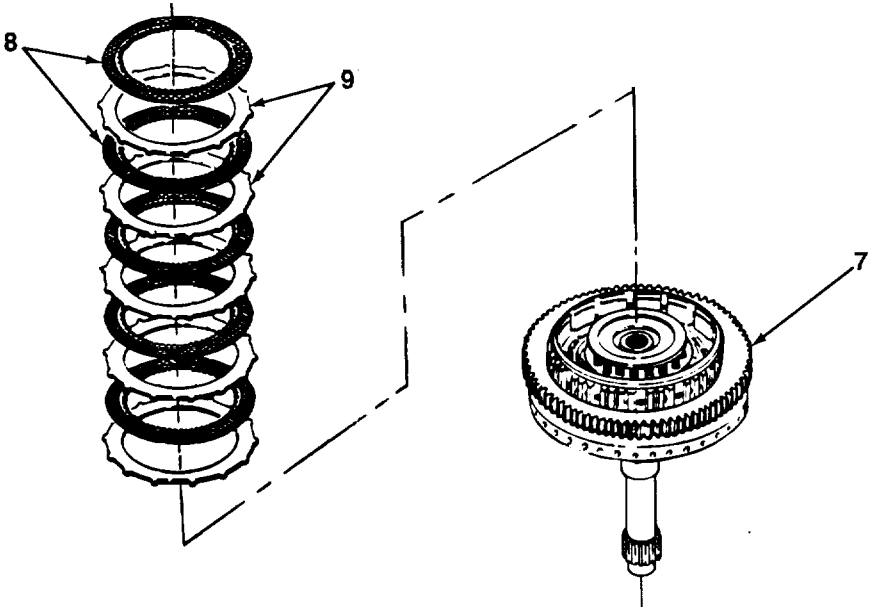

18. Install forward clutch driving hub (2) and retaining ring (1) on hub (3).

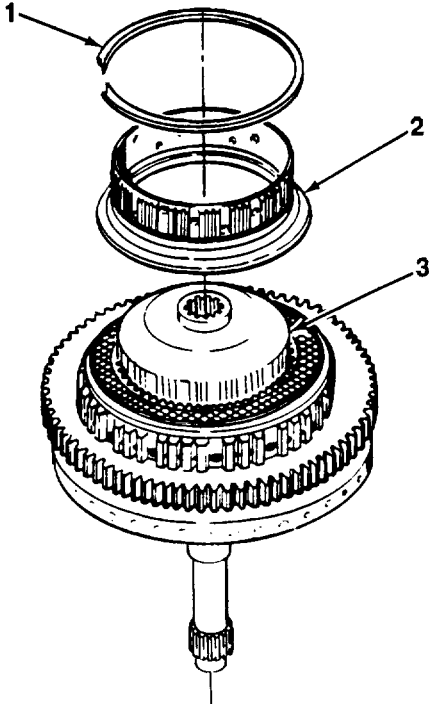

FOLLOW-ON TASKS:

- Install input shaft and forward clutch (see paragraph 6-16).

6-31. FOURTH CLUTCH REPAIR.

This Task Covers:

- a. Disassembly
- b. Cleaning and Inspection
- c. Assembly

Initial Setup:

Equipment Conditions:

- Fourth clutch removed (see paragraph 6-17).

Tools/Test Equipment:

- General mechanic's tool kit
- Field automotive shop set
- Bar and stud
- Forward and fourth clutch spring compressor

Materials/Parts:

- Hydraulic fluid (Item 7, Appendix B)
- Grease (Item 10, Appendix B)
- Dry cleaning solvent (Item 23, Appendix B)
- Two seal rings

General Safety Instructions:

- Dry cleaning solvent is flammable and must not be used near open flame. Use only in a well-ventilated area.

a. DISASSEMBLY

1. Remove snapping (1) and backing plate (2) from housing (4).
2. Remove five clutch disks (3) and five clutch plate (5).

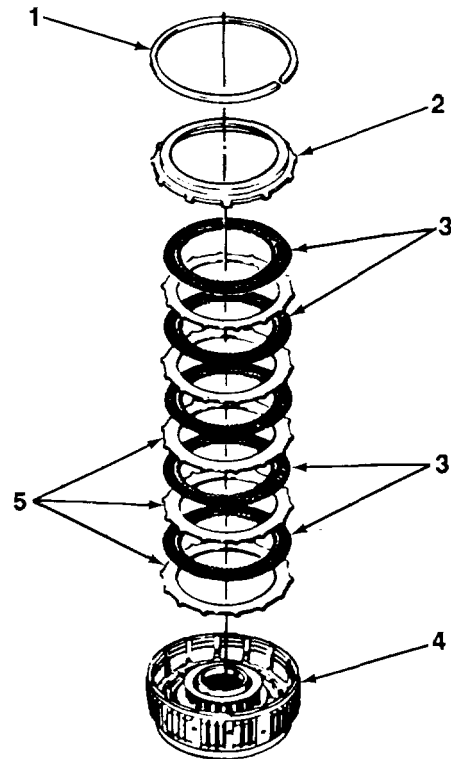

TA703857

6-31. FOURTH CLUTCH REPAIR (Con't).

- 3. Using bar and stud and spring compressor, compress spring retainer (7) and remove snapping (6) from housing (4).
- 4. Remove bar and stud and spring compressor, spring retainer (7), and 20 springs (8) from fourth clutch piston (9).

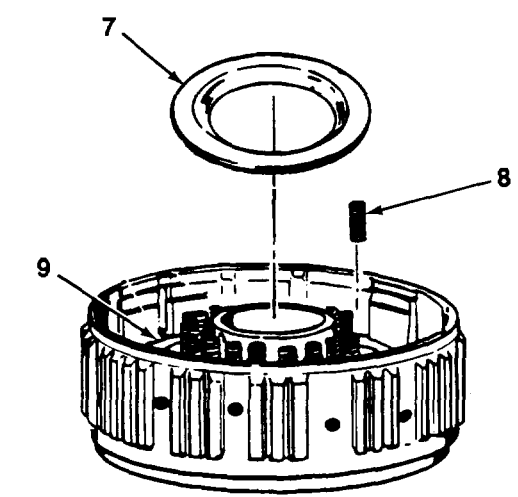
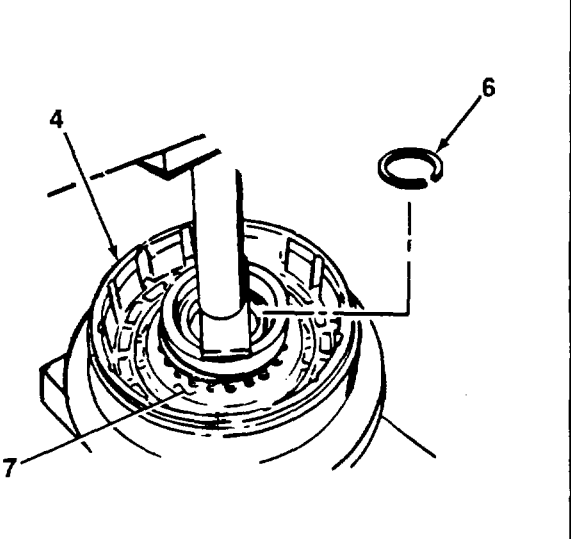

NOTE

Fourth clutch piston is marked A, B, or C. If replacement is necessary, replace only with piston having same marking.

- 5. Remove fourth clutch piston (9) from housing (4).

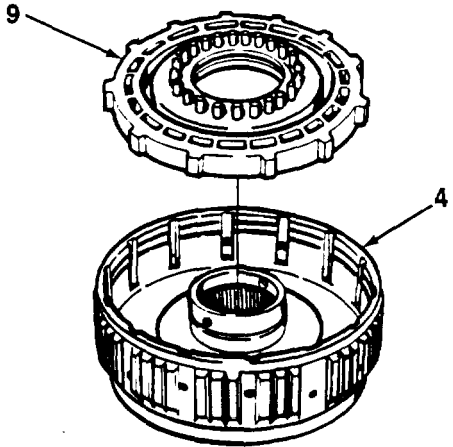

6-31. FOURTH CLUTCH REPAIR (Con't).

6. Remove seal ring (10) from outer surface of fourth clutch piston (9). Discard seal ring.
7. Remove seal ring (11) from Inside housing (4). Discard seal ring.

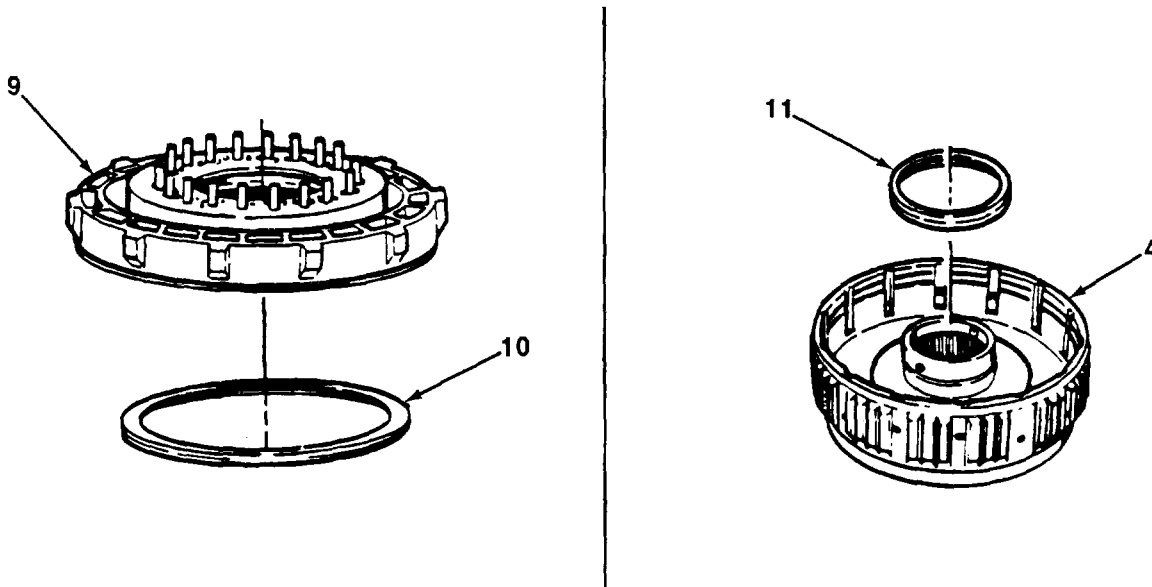

b. CLEANING AND INSPECTION I

WARNING

Dry cleaning solvent, P-D-680, is toxic and flammable. Always wear protective goggles and gloves, and use only in a well-ventilated area. Avoid contact with skin, eyes, and clothes, and DO NOT breathe vapors. DO NOT use near open flame or excessive heat. The solvent's flash point is 100°F-138°F (380C-590C). If you become dizzy while using cleaning solvent, immediately get fresh air and medical help. If solvent contacts eyes, immediately wash your eyes and get medical aid.

1. Clean metal parts, except clutch disks, with dry cleaning solvent.
2. Inspect metal parts for cracks, breaks, wear, or other damage. Replace if damaged.
3. Inspect for broken or deformed springs. Springs must meet these requirements:
 - (a) Length without load: 1.25 in. (3.18 cm).
 - (b) Length with load of 17. -18.9 lb (79.6-84 N): 0.88 in. (22.35 mm).
4. Measure thickness of each of five clutch disks. Disks must measure no less than 0.090 in. (2.286 mm).
5. Measure thickness of each of five clutch plates. Plates must measure no less than 0.0993 in. (2.5222 mm).

TA703859

6-31. FOURTH CLUTCH REPAIR (Con't).

- 6. Check four ball bearings (12) for damage by applying a load against ball bearing in direction of housing (4). Ball bearing must withstand at least 30 lb (133.45 N). Replace only if necessary.

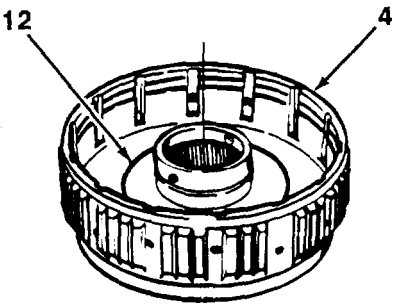

c. ASSEMBLY

- 1. Apply thin coat of hydraulic fluid to surface of all metal parts including clutch disks (3) and clutch plates (5).

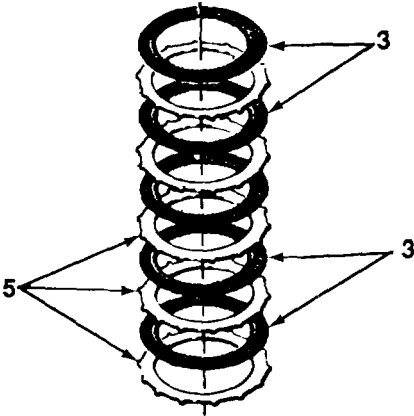

6-31. FOURTH CLUTCH REPAIR (Con't).

2. Apply thin coat of grease to surface of new seal rings (10 and 11).
3. With spring pins of fourth clutch piston (9) facing downward, install seal ring (10) to outer surface of fourth clutch piston with lip of seal ring facing upward.
4. Install seal ring (11) inside housing (4) with lip of seal ring facing downward.

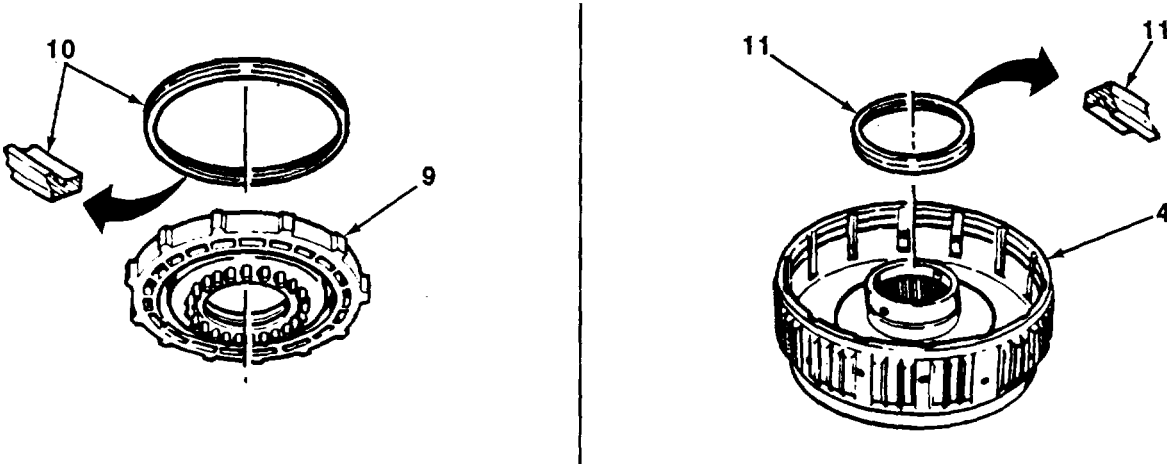

5. Install fourth clutch piston (9) into housing (4).

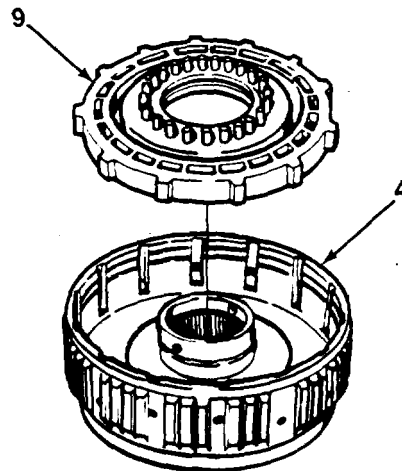

TA703861

6-31. FOURTH CLUTCH REPAIR (Con't).

- 6. Beginning with one clutch plate (5), alternately install five clutch plates and five clutch disks (3) into housing (4).
- 7. Install backing plate (2) and snapping (1) into housing (4).
- 8. While lifting backing plate (2) against snapping (1), measure clearance between top clutch plate (5) and backing plate. Clearance must be 0.080-0.120 in. (2.032-3.048 mm).
- 9. If clearance is not within specified limits, replace clutch disks (3) and clutch plates (5) until proper clearance is obtained. Clearance closer to 0.080 in. (2.032 mm) is preferred.

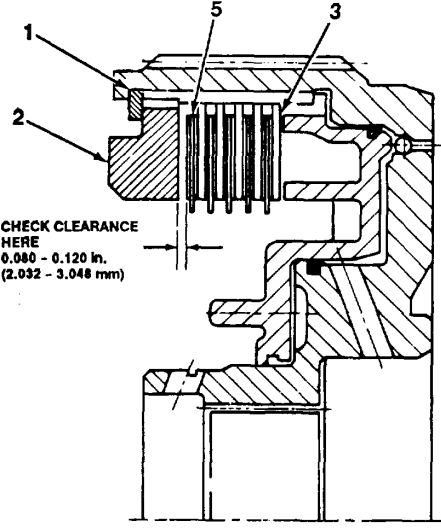
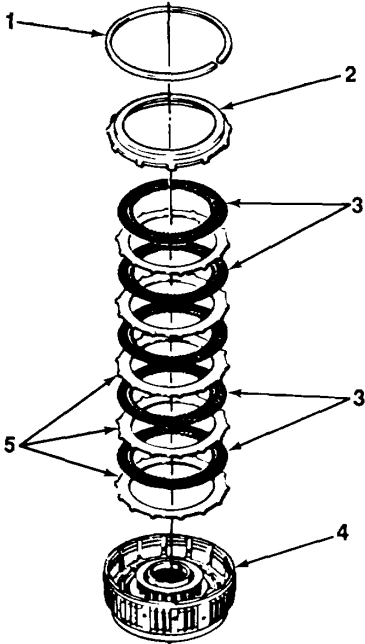

TA703862

6-31. FOURTH CLUTCH REPAIR (Con't).

10. Install 20 springs (8) and spring retainer (7) to fourth clutch piston (9).
11. Using bar and stud and spring compressor, press spring retainer (7) downward just enough to install snapping (6) in housing (4). Remove bar and stud and spring compressor.

FOLLOW-ON TASKS:

- Install fourth clutch (see paragraph 6-17).

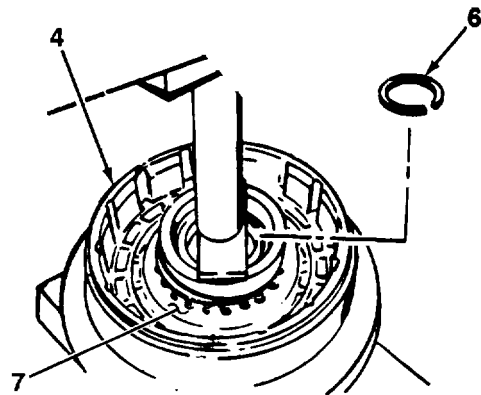
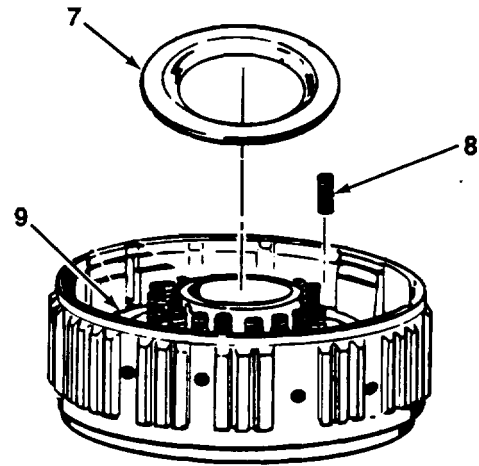

TA703863

6-32. LOW TRIMMER VALVE REPAIR.

This Task Covers:

- | | |
|--|---|
| <ul style="list-style-type: none"> a. Disassembly b. Cleaning and Inspection | <ul style="list-style-type: none"> c. Assembly |
|--|---|

Initial Setup:

Equipment Conditions:

- Low trimmer valve removed (see paragraph 6-12).

Tools/Test Equipment:

- General mechanic's tool kit
- Field automotive shop set

Materials/Parts:

- Hydraulic fluid (Item 7, Appendix B)
- Dry cleaning solvent (Item 23, Appendix B)
- One spring pin

General Safety Instructions:

- Dry cleaning solvent is flammable and must not be used near open flame. Use only in a well-ventilated area.
- Compressed air used for cleaning or drying purposes, or for clearing restrictions, should never exceed 30 psi (207 kPa).

a. DISASSEMBLY

1. Press Inward on plug (8) and remove spring pin (2). Discard spring pin.
2. Release pressure and remove plug (8), valve stop (7), secondary spring (6), primary spring (5), plug (4), and low trimmer valve (3) from low trimmer valve body (1).

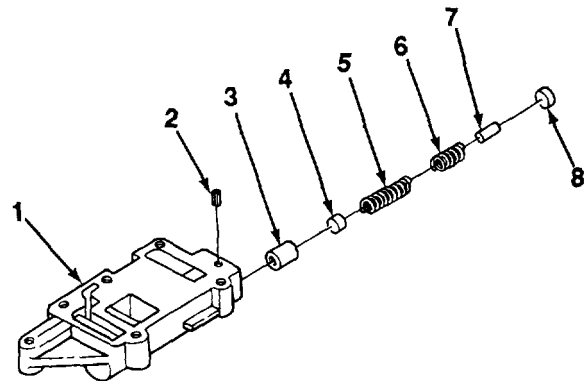
**b. CLEANING AND INSPECTION I****WARNING**

Dry cleaning solvent, P-D-680, is toxic and flammable. Always wear protective goggles and gloves, and use only in a well-ventilated area. Avoid contact with skin, eyes, and clothes, and DO NOT breathe vapors. DO NOT use near open flame or excessive heat. The solvent's flash point is 1000F-1380F (380C-590C). If you become dizzy while using cleaning solvent, Immediately get fresh air and medical help. If solvent contacts eyes, Immediately wash your eyes and get medical aid.

1. Clean metal parts with dry cleaning solvent.

TA703864

6-32. LOW TRIMMER VALVE REPAIR (Con't).

- Inspect metal parts for cracks, scratches, wear, and other damage. Replace if damaged.

WARNING

Dry cleaning solvent, P-D-680, is toxic and flammable. Always wear protective goggles and gloves, and use only in a well-ventilated area. Avoid contact with skin, eyes, and clothes, and DO NOT breathe vapors. DO NOT use near open flame or excessive heat. The solvent's flash point is 1000F-1380F (380C-59°C). If you become dizzy while using cleaning solvent, immediately get fresh air and medical help. If solvent contacts eyes, immediately wash your eyes and get medical aid.

- Inspect oil passages in low trimmer valve body to ensure that they are clean. If necessary, work soft wire through oil passages to remove foreign matter. Flush with dry cleaning solvent.

WARNING

Compressed air used for cleaning or drying purposes, or for clearing restrictions, should never exceed 30 psi (207 kPa). Wear protective clothing (goggles/shield, gloves, etc.) and use caution to avoid injury to personnel.

- Dry oil passages in low trimmer valve body with compressed air.

c. ASSEMBLY

- Apply thin coat of hydraulic fluid to surface of metal parts.
- Install low trimmer valve (3), recessed end first, into low trimmer valve body (1).
- Install plug (4), primary spring (5), secondary spring (6), valve stop (7), and plug (8).
- Press inward on plug (8) and install new spring pin (2).

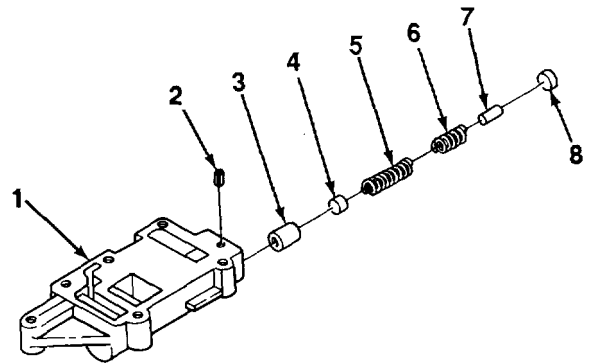
**FOLLOW-ON TASKS:**

- Install low trimmer valve (see paragraph 6-12).

TA703865

6-33. LOW SHIFT VALVE REPAIR.

This Task Covers:

- | | |
|----------------------------|-------------|
| a. Disassembly | c. Assembly |
| b. Cleaning and Inspection | |

Initial Setup:

Equipment Conditions:

- Low shift valve removed (see paragraph 6-13).

Tools/Test Equipment:

- General mechanic's tool kit
- Field automotive shop set

Materials/Parts:

- Hydraulic fluid (Item 7, Appendix B)
- Dry cleaning solvent (Item 23, Appendix B).

General Safety Instructions:

- Dry cleaning solvent is flammable and must not be used near open flame. Use only in a well-ventilated area.
- Compressed air used for cleaning or drying purposes, or for clearing restrictions, should never exceed 30 psi (207 kPa).

a. DISASSEMBLY

1. Press inward on plug (7) and remove pin (2).
2. Release pressure and remove plug (7), valve stop (6), spring (5), and relay valve (4) from low shift valve body (1).
3. Mark position of adjusting ring (8) in low shift valve body (1) for assembly.
4. Press inward on adjusting ring (8) and remove pin (3).
5. Release pressure and remove adjusting ring (8), washer (9), valve stop (10), spring (11), and low shift valve (12) from low shift valve body (1).

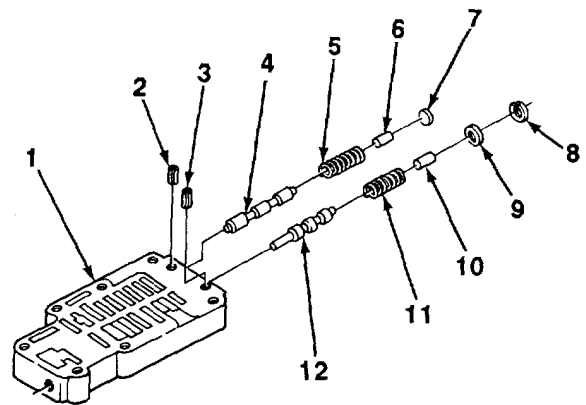
**b. CLEANING AND INSPECTION****WARNING**

Dry cleaning solvent, P-D-680, is toxic and flammable. Always wear protective goggles and gloves, and use only in a well-ventilated area. Avoid contact with skin, eyes, and clothes, and DO NOT breathe vapors. DO NOT use near open flame or excessive heat. The solvent's flash point is 100°F-138°F (38°C-59°C). If you become dizzy while using cleaning solvent, immediately get fresh air and medical help. If solvent contacts eyes, immediately wash your eyes and get medical aid.

1. Clean metal parts with dry cleaning solvent.

TA703866

6-33. LOW SHIFT VALVE REPAIR (Con't).

2. Inspect metal parts for cracks, scratches, wear, and other damage. Replace if damaged.

WARNING

Dry cleaning solvent, PD680, is toxic and flammable. Always wear protective goggles and gloves, and use only in a well ventilated area. Avoid contact with skin, eyes, and clothes, and DO NOT breathe vapors. DO NOT use near open flame or excessive heat. The solvent's flash point is 100°F/138°F (38°C/59°C). If you become dizzy while using cleaning solvent, immediately get fresh air and medical help. If solvent contacts eyes, immediately wash your eyes and get medical aid.

3. Inspect oil passages in low shift valve body to ensure that they are clean. If necessary, work soft wire through oil passages to remove foreign matter. Flush with dry cleaning solvent.

WARNING

Compressed air used for cleaning or drying purposes, or for clearing restrictions, should never exceed 30 psi (207 kPa). Wear protective clothing (goggles/shield, gloves, etc.) and use caution to avoid injury to personnel.

4. Dry oil passages in low shift valve body with compressed air.

c. ASSEMBLY

1. Apply thin coat of hydraulic fluid to surface of metal parts.
2. Install low shift valve (12), spring (11), valve stop (10), washer (9), and adjusting ring (8).
3. Align marks on adjusting ring (8) and low shift valve body (1) and install pin (3).
4. Install relay valve (4), spring (5), valve stop (6), and plug (7).
5. Press inward on plug (7) and install pin (2).

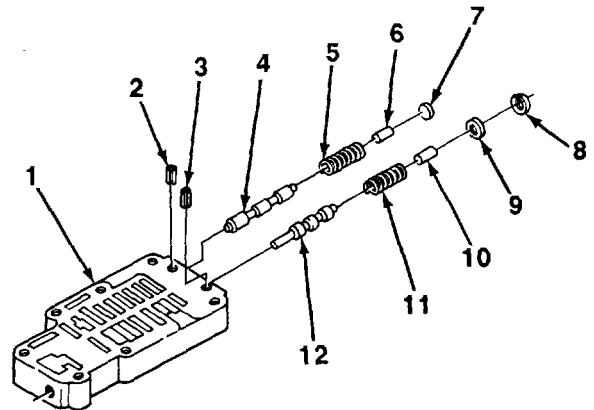
**FOLLOW-ON TASKS:**

- Install low shift valve (see paragraph 6-13).

TA703867

6-34. CONTROL VALVE REPAIR.

This Task Covers:

- | | |
|--|---|
| <ul style="list-style-type: none"> a. Disassembly b. Cleaning and Inspection | <ul style="list-style-type: none"> c. Assembly |
|--|---|

Initial Setup:

Equipment Conditions:

- Control valve removed (see paragraph 6-14).

Tools/Test Equipment:

- General mechanic's tool kit
- Field automotive shop set

Materials/Parts:

- Hydraulic fluid (Item 7, Appendix B)
- Grease (Item 10, Appendix B)
- Dry cleaning solvent (Item 23, Appendix B)
- One retaining pin

General Safety Instructions:

- Dry cleaning solvent is flammable and must not be used near open flame. Use only in a well-ventilated area.
- Compressed air used for cleaning or drying purposes, or for clearing restrictions, should never exceed 30 psi (207 kPa).

a. DISASSEMBLY**CAUTION**

Seven balls in oil transfer plate will fall free if transfer plate and held firmly together when handling.

1. While holding control valve body (4), separator plate (6), and oil transfer plate (1) together as an assembly, place on work surface with modulator valve body (5) facing upward.
2. Remove three screws (2) and modulator valve body (5) from oil transfer plate (1).
3. Mark position of spring ring (3) in modulator valve body (5) for assembly.

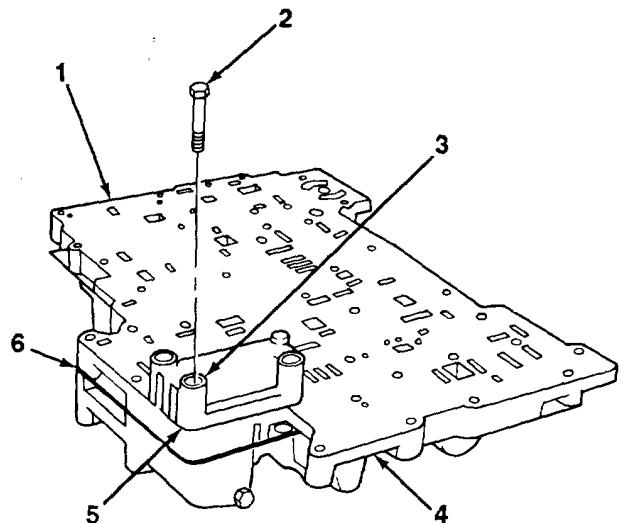

TA703868

6-34. CONTROL VALVE REPAIR (Con't).

WARNING

Valves in control valve body are under spring pressure. Use care when removing control valve parts to avoid injury.

NOTE

As valve parts are removed, keep parts together in groups. Mark control valve body and parts groups for assembly.

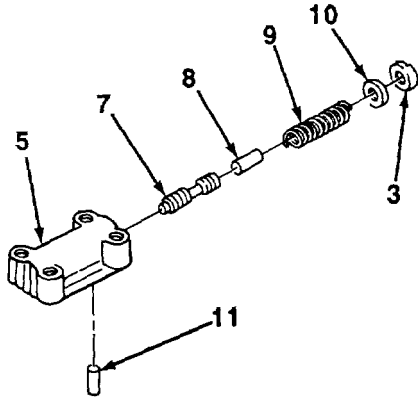

- 4. Press inward on spring ring (3) and remove retaining pin (11), spring ring, washer (10), spring (9), spring ring pin (8), and valve (7) from modulator valve body (5).
- 5. While holding oil transfer plate (1) and separator plate (6) place on work surface.
- 6. Remove separator plate (6) from oil transfer plate (1).

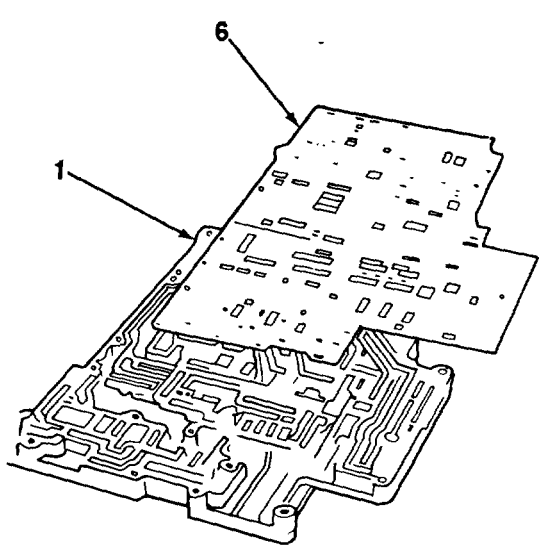
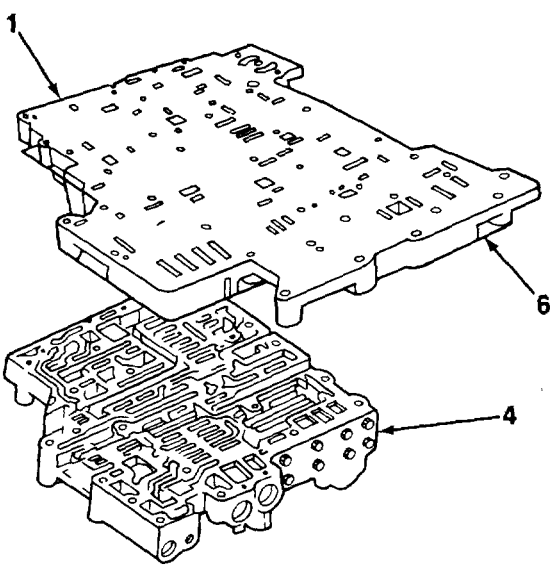

TA703869

6-34. CONTROL VALVE REPAIR (Con't).

NOTE

Ensure that the location and diameter measurement are noted for assembly.

- 7. Remove seven balls (12) from oil transfer plate (1).
- 8. Press inward on washer (16) and remove pin (17) from end of lubrication valve pin (13).
- 9. Remove washer (16), spring (15), lubrication valve (14), and lubrication valve pin (13) from oil transfer plate (1).
- 10. Remove priority valve (18), spring (19), and valve pin (20) from top of control valve body (4).
- 11. Remove plug (23) and strainer (24).

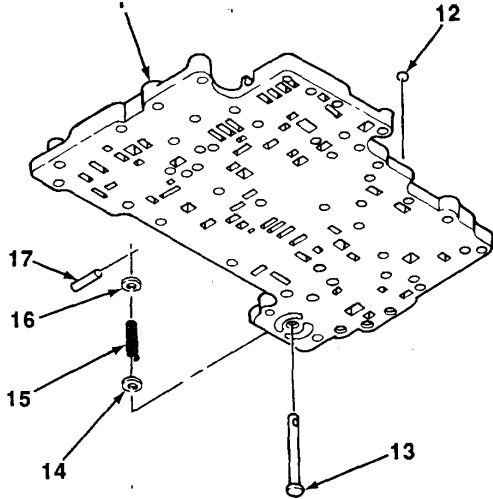

WARNING

Cover is under spring pressure. Use care when removing cover to avoid injury.

- 12. Remove eight bolts (22) and cover (21).

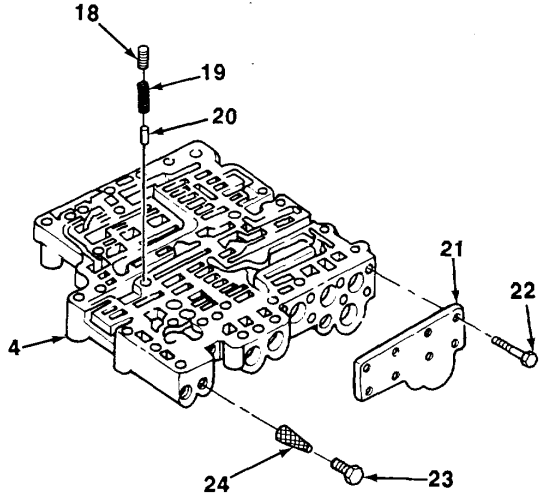

6-34. CONTROL VALVE REPAIR (Con't).

- 13. Remove valve stop (29), primary spring (28), secondary spring (27), plug (26), and trimmer valve (25) from control valve body (4).
- 14. Remove valve stop (34), spring (33), spring (32), plug (31), and trimmer valve (30) from control valve body (4).

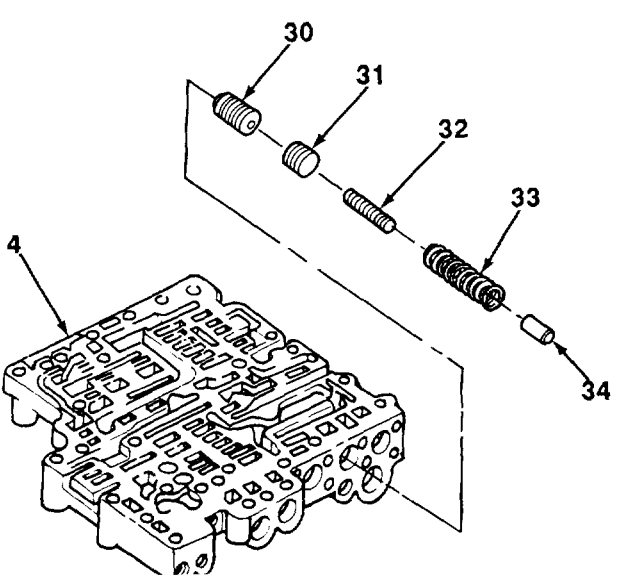
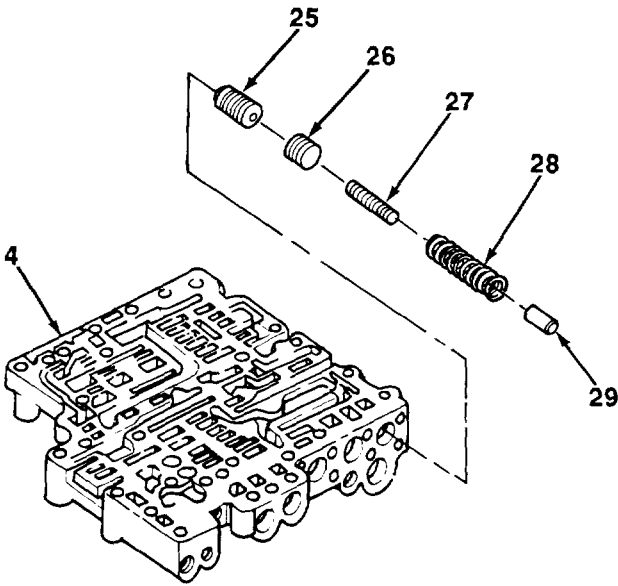

- 15. Remove valve stop (38), spring (39), spring (40), plug (41), and trimmer valve (42) from control valve body (4).
- 16. Remove valve stop (37), spring (36), and accumulator valve (35) from control valve body (4).

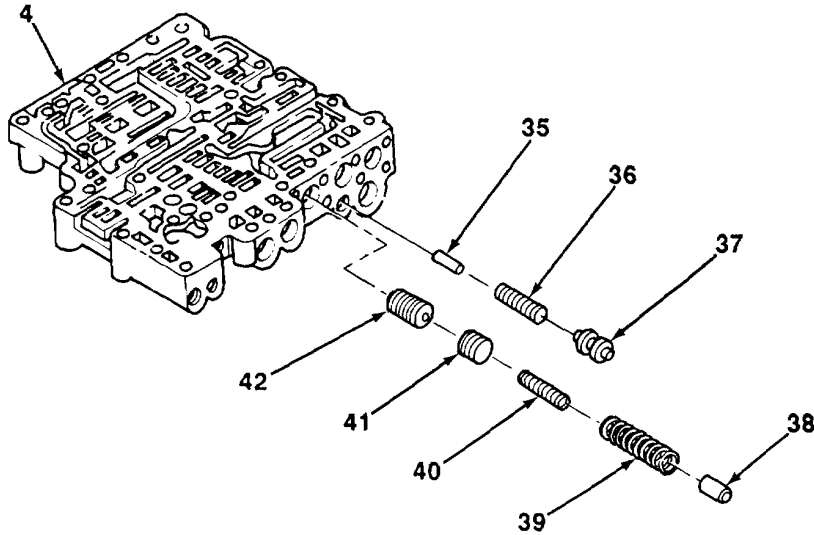

6-34. CONTROL VALVE REPAIR (Con't).

17. Remove valve stop (47), spring (46), spring (45), plug (44), and trimmer valve (43) from control valve body (4).

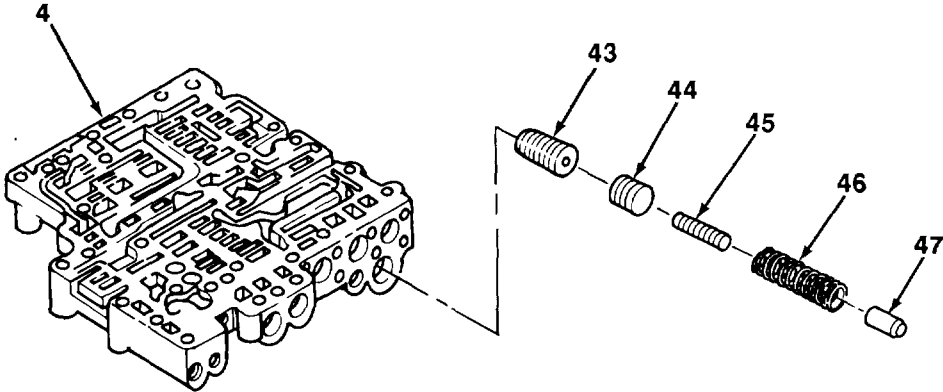

8. Remove retaining pin (48), valve stop (51), spring (50), and transmission relay valve (49) from control valve body (4).

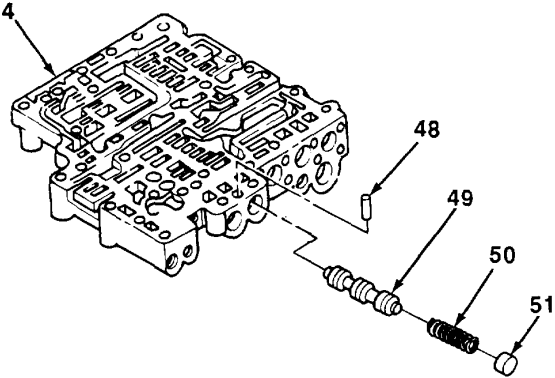

TA703872

6-34. CONTROL VALVE REPAIR (Con't).

19. Remove retaining pin (52), spacer (55), spring (54), and relay valve piston (53) from control valve body (4).
20. Remove retaining pin (59), valve plug (56), spring (57), and accumulator valve (58) from control valve body (4). Discard retaining pin.
21. Remove retaining pin (60), plug (64), valve stop (63), regulating spring (62), and directional slide (61) from control valve body (4).

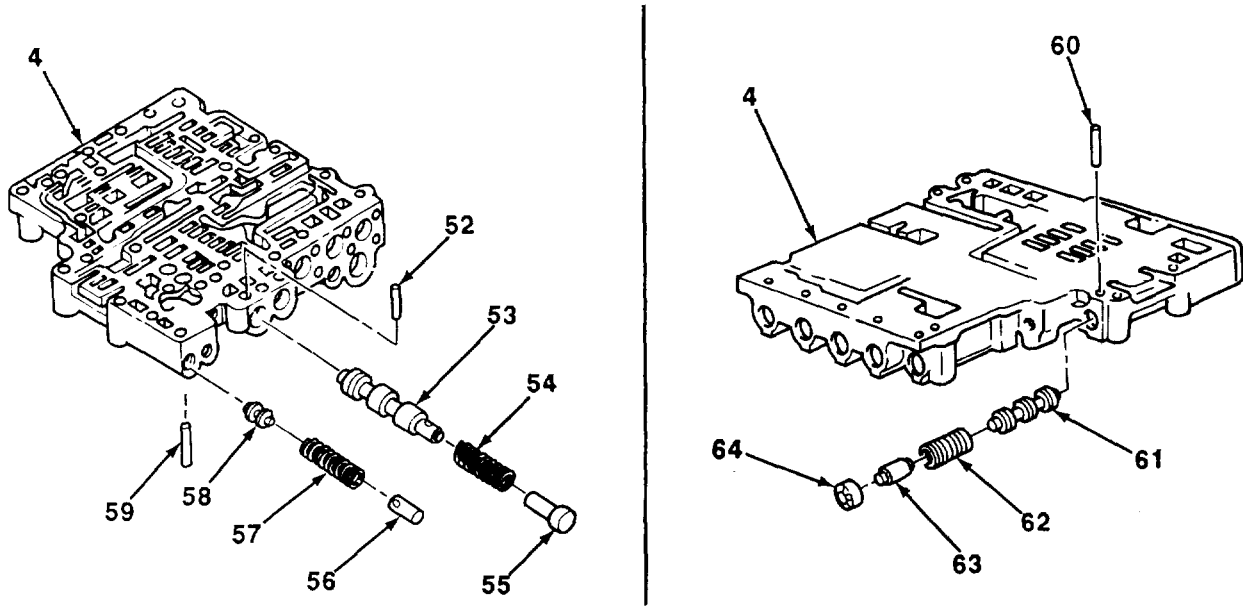

22. Remove bolt (66) and manual selector valve (67).
23. Mark position of spring ring (68) in control valve body (4) for assembly.
24. Press Inward on spring ring (68) and remove retaining pin (65), spring ring, valve stop (69), spring (70), modulator valve (71), and shift valve (72).

TA703873

6-34. CONTROL VALVE REPAIR (Con't).

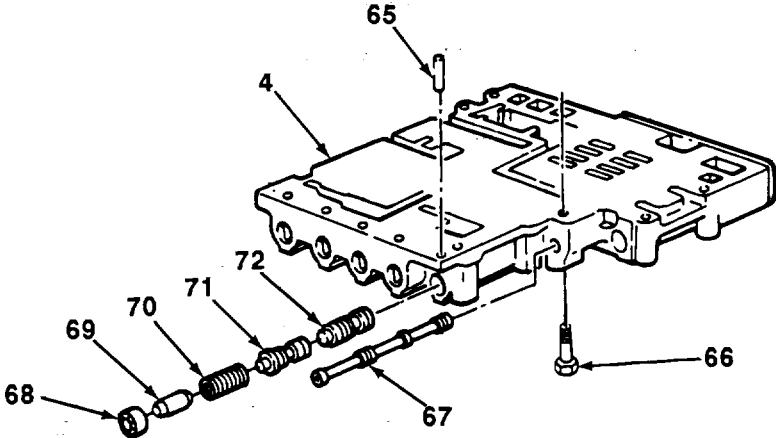

- 25. Mark position of spring ring (78) in control valve body (4) for assembly.
- 26. Press Inward on spring ring (78) and remove retaining pin (73), spring ring, valve stop (77), spring (76), modulator valve (75), and shift valve (74).

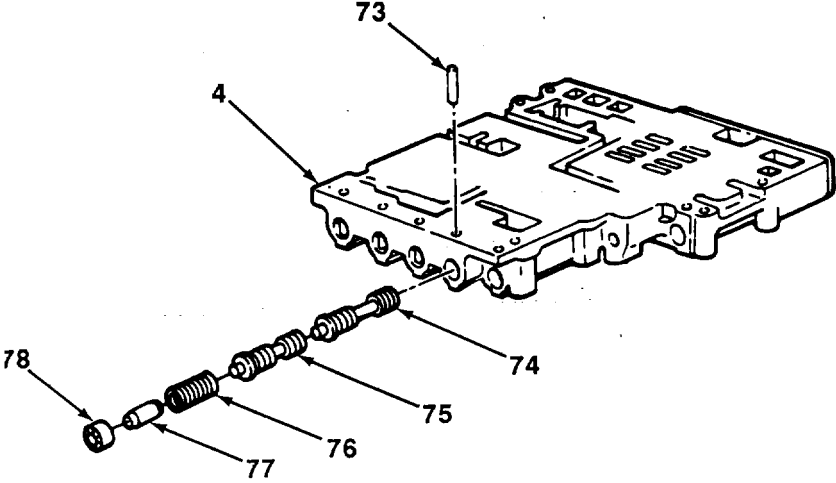

ta703874

6-34. CONTROL VALVE REPAIR (Con't).

- 27. Mark position of spring ring (84) in control valve body (4) for assembly.
- 28. Press inward on spring ring (84) and remove retaining pin (79), spring ring, valve stop (83), spring (82), modulator valve (81), and shift valve (80).

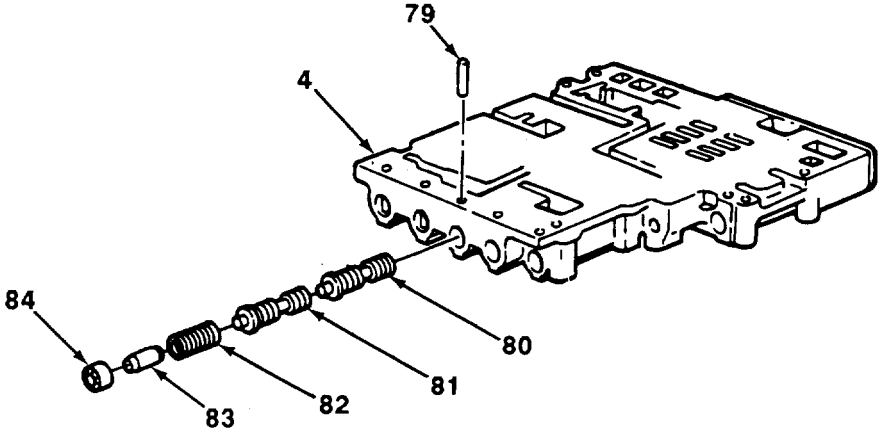

- 29. Remove retaining pin (85), valve stop (88), spring (87), and transmission relay valve (86) from control valve body (4).

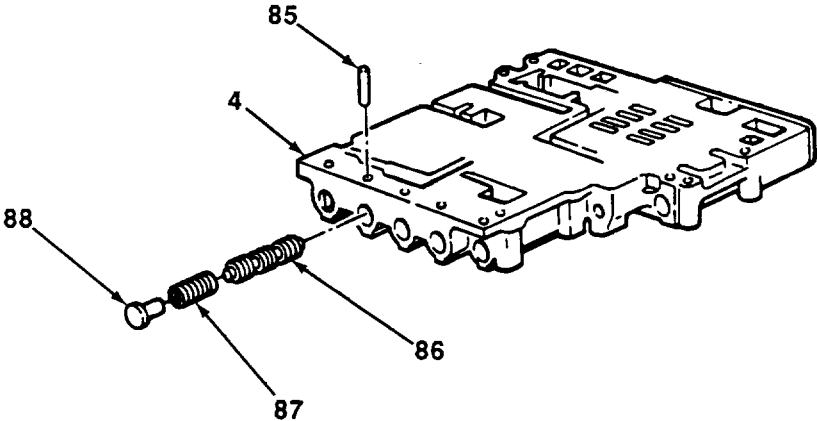

ta703875

6-34. CONTROL VALVE REPAIR (Con't).

30. Remove retaining pin (89), shoulder pin (92), spring (91), and trimmer regulator valve (90) from control valve body (40)

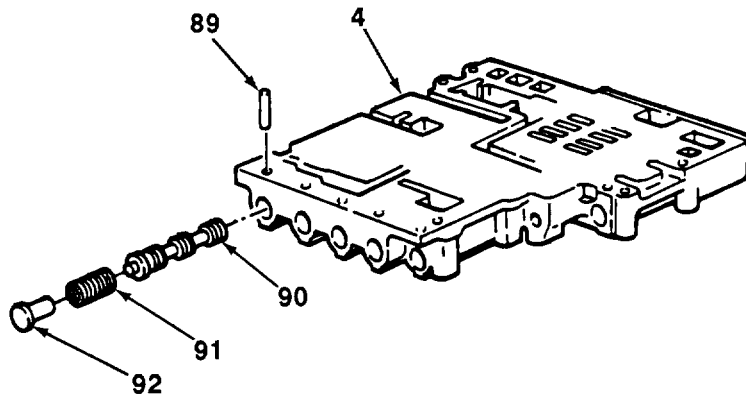
**b. CLEANING AND INSPECTION I****WARNING**

Dry cleaning solvent, PD680, is toxic and flammable. Always wear protective goggles and gloves, and use only in a well-ventilated area. Avoid contact with skin, eyes, and clothes, and **DO NOT** breathe vapors. **DO NOT** use near open flame or excessive heat. The solvent's flash point is 100°F/138°F (38°C/59°C). If you become dizzy while using cleaning solvent, immediately get fresh air and medical help. If solvent contacts eyes, immediately wash your eyes and get medical aid.

1. Clean metal parts with dry cleaning solvent.

WARNING

Compressed air used for cleaning or drying purposes, or for clearing restrictions, should never exceed 30 psi (207 kPa). Wear protective clothing (goggles/shield, gloves, etc.) and use caution to avoid injury to personnel.

2. Dry control valve with compressed air.
3. Inspect metal parts for cracks, breaks, wear, and other damage. Replace if damaged.
4. Inspect bores of control valve for scratches and other damage.

TA703876

6-34. CONTROL VALVE REPAIR (Con't).**WARNING**

- **Dry cleaning solvent, P-D-680, is toxic and flammable. Always wear protective goggles and gloves, and use only in a well-ventilated area. Avoid contact with skin, eyes, and clothes, and DO NOT breathe vapors. DO NOT use near open flame or excessive heat. The solvent's flash point is 1000F-138°F (380C-590C). If you become dizzy while using cleaning solvent, immediately get fresh air and medical help. If solvent contacts eyes, immediately wash your eyes and get medical aid.**
 - **Compressed air used for cleaning or drying purposes, or for clearing restrictions, should never exceed 30 psi (207 kPa). Wear protective clothing (goggles/shield, gloves, etc.) and use caution to avoid injury to personnel.**
5. Inspect oil passages in oil transfer plate to ensure they are clean. Flush with dry cleaning solvent and dry with compressed air.
 6. Inspect for broken or deformed springs. Springs must meet the requirements shown in Table 6-1:

Table 6-1. Spring Load-Length Requirements.

Callout No	Spring	Length Without Load	Length With Load	Load
9	Modulator Valve	1.47 in (37.34 mm)	0.80 in (20.32 mm)	11.90-13.10 lb (52.9-58.3 N)
15	Lubrication Valve	2.48 in (62.99 mm)	1.97 in (50.04 mm)	32.25-37.05 lb (143.45-164.81 N)
19	Priority Valve	1.17 in (29.69 mm)	0.94 in (23.88 mm)	8.60-8.80 lb (38.3-39.14 N)
27	Third Clutch Trimmer Valve (inner)	1.69 in (42.93 mm)	1.10 in (27.94 mm)	32.60-39.80 lb (145.01-177.04 N)
28	Third Clutch Trimmer Valve (outer)	2.96 in (75.18 mm)	1.10 in (27.94 mm)	15.95-17.65 lb (70.95-78.51 N)
32	Second Clutch Trimmer Valve (inner)	1.69 in (42.93 mm)	1.10 in (27.94 mm)	32.60-39.80 lb (145.01-177.04 N)
33	Second Clutch Trimmer Valve (outer)	2.30 in (58.42 mm)	1.94 in (49.28 mm)	9.40-11.40 lb (41.81-50.71 N)
36	Accumulator Valve	2.77 in (70.23 mm)	1.49 in (37.85 mm)	11.60-12.80 lb (51.60-56.94 N)
39	Fourth Clutch Trimmer Valve (outer)	2.38 in (60.45 mm)	1.94 in (49.28 mm)	29.00-35.00 lb (128.99-155.69 N)

6-34. CONTROL VALVE REPAIR (Con't).**Table 6-1. Spring Load-Length Requirements (Con't).**

Callout No	Spring	Length Without Load	Length With Load	Load
40	Fourth Clutch Trimmer Valve (inner)	1.45 in (36.83 mm)	1.10 in (27.94 mm)	21.70-25.30 lb (96.52-112.54 N)
45	First Clutch Trimmer Valve (inner)	1.69 in (42.93 mm)	1.10 in (27.94 mm)	32.60-39.80 lb (145.01-177.04 N)
46	First Clutch Trimmer Valve (outer)	2.96 in (75.18 mm)	1.10 in (27.94 mm)	15.95-17.65 lb (70.95-78.51 N)
50	Transmission Relay Valve, 3	2.18 in (55.37 mm)	1.20 in (30.48 mm)	16.20-19.80 lb (72.06-88.07 N)
54	Relay Valve, 122	1.52 in (38.61 mm)	1.10 in (27.94 mm)	7.20-8.80 lb (32.03-39.14 N)
57	Accumulator Valve	1.84 in (46.61 mm)	0.70 in (17.78 mm)	9.60-10.60 lb (42.70-47.15 N)
62	Regulating	1.70 in (43.10 mm)	1.15 in (29.21 mm)	5.29-5.51 lb (23.53-24.51 N)
70	Shift Valve, 1-2	2.67 in (67.69 mm)	1.15 in (29.21 mm)	13.45-13.85 lb (59.83-61.61 N)
76	Shift Valve, 2-3	2.57 in (65.28 mm)	1.15 in (29.21 mm)	12.74-13.26 lb (56.67-58.98 N)
82	Shift Valve, 3-4	2.75 in (69.85 mm)	1.15 in (29.21 mm)	9.25-9.95 lb (41.14-44.26 N)
87	Transmission Relay Valve, 3-4	2.18 in (55.37 mm)	1.20 in (30.48 mm)	16.20-19.80 lb (72.06-88.07 N)
91	Transmission Regulator Valve	1.78 in (45.21 mm)	0.78 in (19.81 mm)	3.80-4.20 lb (16.90-18.68 N)

6-34. CONTROL VALVE REPAIR (Con't).

c. ASSEMBLY

- 1. Apply thin coat of hydraulic fluid to all valve parts as they are assembled.
- 2. Install trimmer regulator valve (90), spring (91), and shoulder pin (92) In control valve body (4). Install retaining

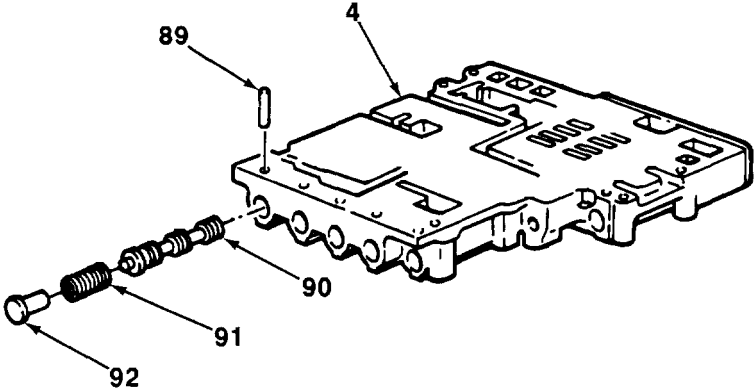

- 3. Install transmission relay valve (86), spring (87), and valve stop (88) in control valve body (4). Install retaining pin 185).

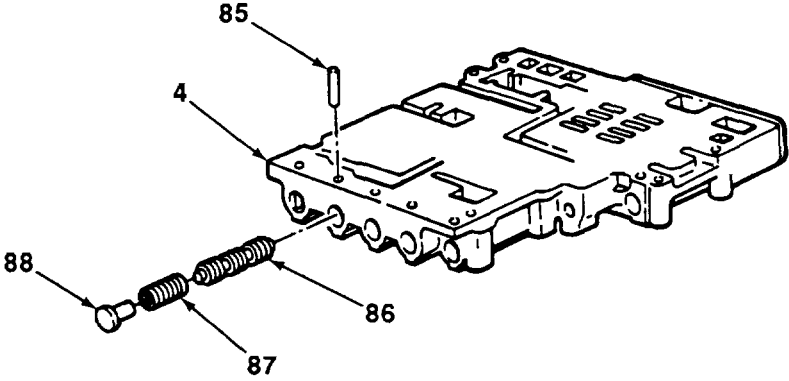

6-34. CONTROL VALVE REPAIR (Con't).

NOTE

Ensure that marks on spring ring and control valve body aline when retaining pin is installed.

- 4. Install shift valve (80), modulator valve (81), spring (82), valve stop (83), and spring ring (84). Press inward on spring ring and install retaining pin (79).

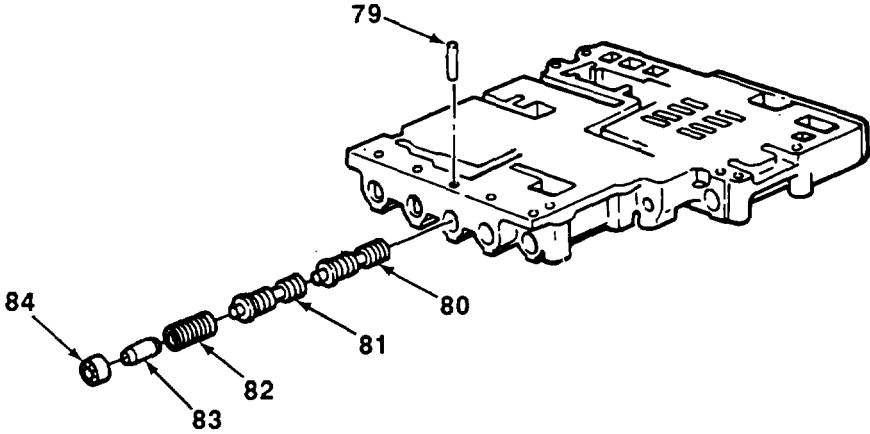

- 5. Install shift valve (74), modulator valve (75), spring (76), valve stop (77), and spring ring (78). Press inward on spring ring and install retaining pin (73).

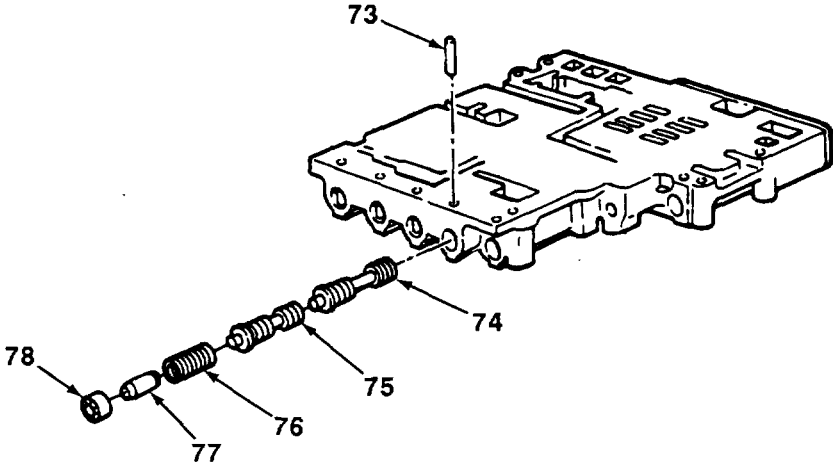

6-34. CONTROL VALVE REPAIR (Con't).

- 6. Install shift valve (72), modulator valve (71), spring (70), valve stop (69), and spring ring (68). Press inward on spring ring and install retaining pin (65) in control valve body (4).

NOTE

Ensure that flat end of bolt aligns with flat side of manual selector valve.

- 7. Install manual selector valve (67) and bolt (66). Torque bolt to 36-43 lb.-ft. (49-58 N.m).

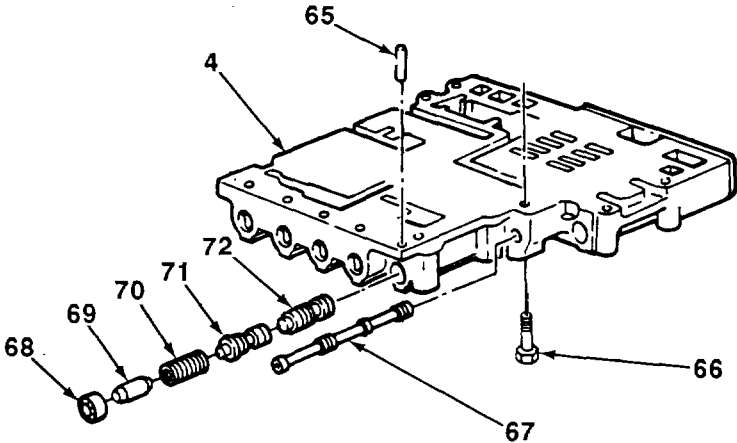

- 8. Install directional slide (61), regulating spring (62), valve stop (63), and plug (64) with retaining pin (60) in control valve body (4).

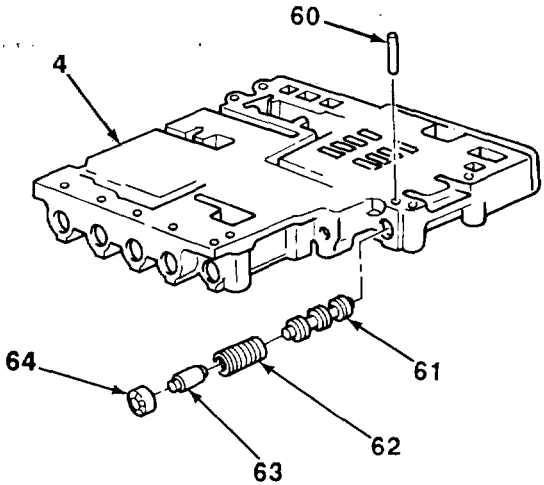

6-34. CONTROL VALVE REPAIR (Con't).

- 9. Install accumulator valve (58), spring (57), and valve plug (56) with new retaining pin (59) in control valve body (4).
- 10. Install relay valve piston (53), spring (54), and spacer (55) with retaining pin (52).
- 11. Install transmission relay valve (49), spring (50), and valve stop (51) with retaining pin (48) in control valve body (4).

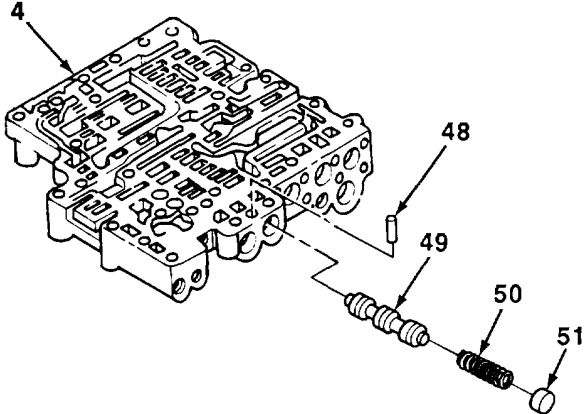
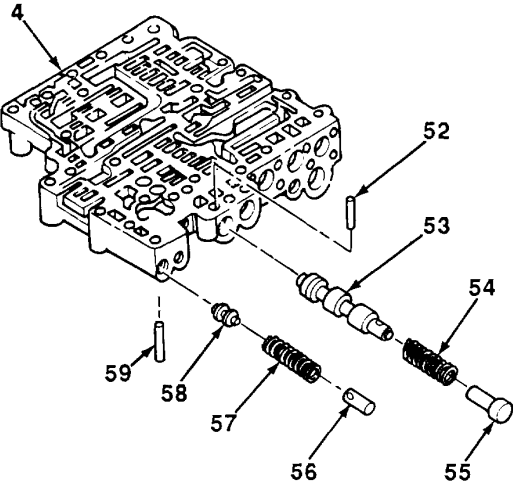

TA703880

6-34. CONTROL VALVE REPAIR (Con't).

12. Install trimmer valve (43), plug (44), spring (45), spring (46), and valve stop (47) in control valve body (4).

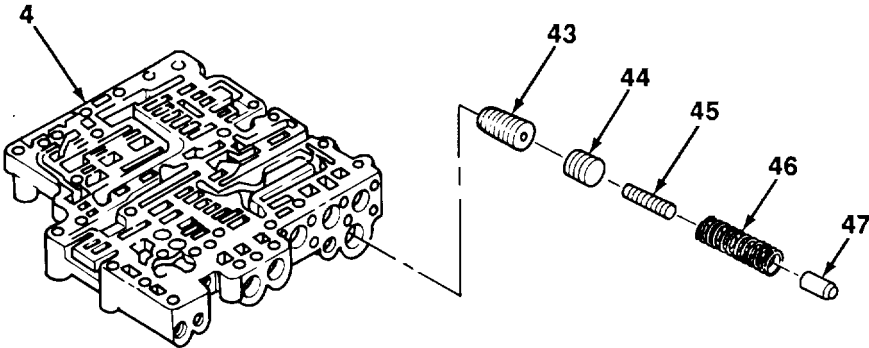

13. Install accumulator valve (35), spring (36), and valve stop (37) in control valve body (4).

14. Install trimmer valve (42), plug (41), spring (40), spring (39), and valve stop (38) in control valve body.

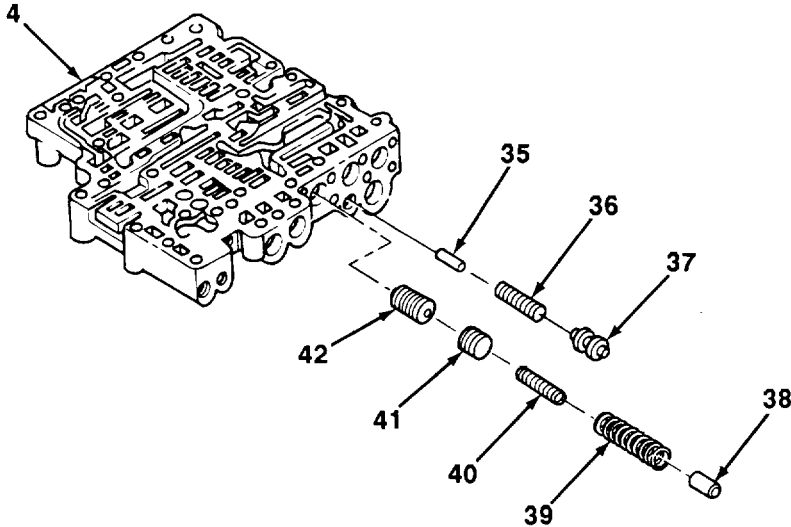

15. Install trimmer valve (30), plug (31), spring (32), spring (33), and valve stop (34) in control valve body (4).

16. Install trimmer valve (25), plug (26), secondary spring (27), primary spring (28), and valve stop (29) in control valve body (4).

6-34. CONTROL VALVE REPAIR (Con't).

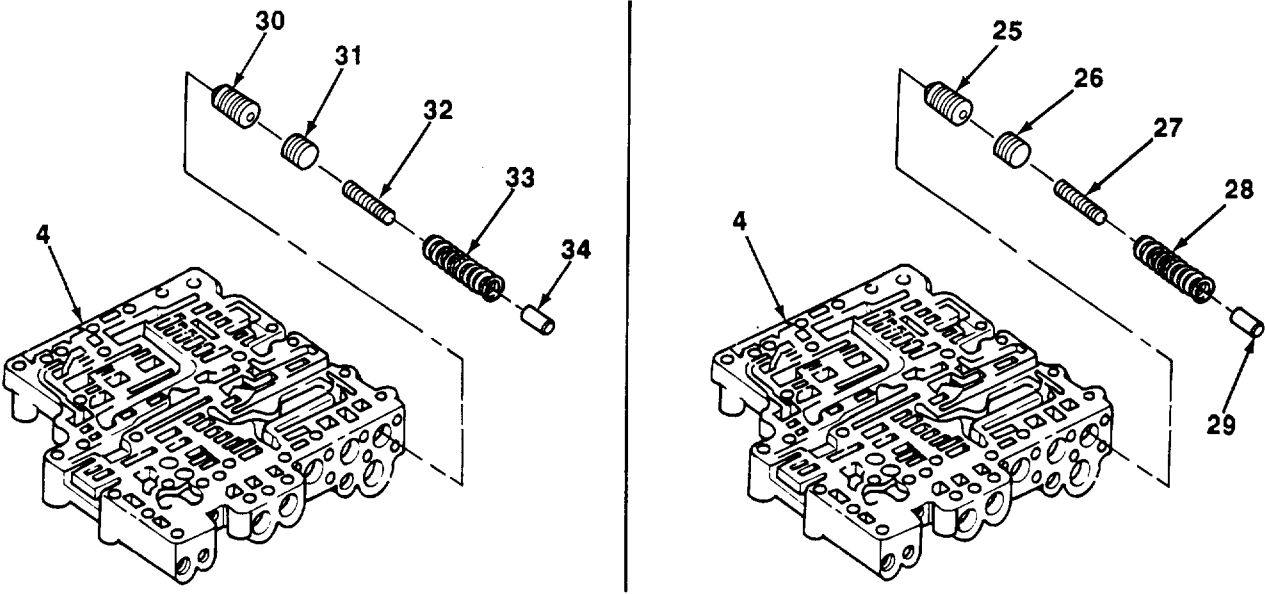

WARNING

Cover will be under spring pressure. Use care when installing cover to avoid injury

- 17. Press cover (21) to control valve body (4) and install eight bolts (22). Torque bolts to 9-11 lb.-ft. (12-15 Nom).
- 18. Install strainer (24), open end first, and plug (23). Torque plug to 50-60 lb.-in. (67-81 Nom).
- 19. Install valve pin (20), spring (19), and priority valve (18) to top of control valve body (4).

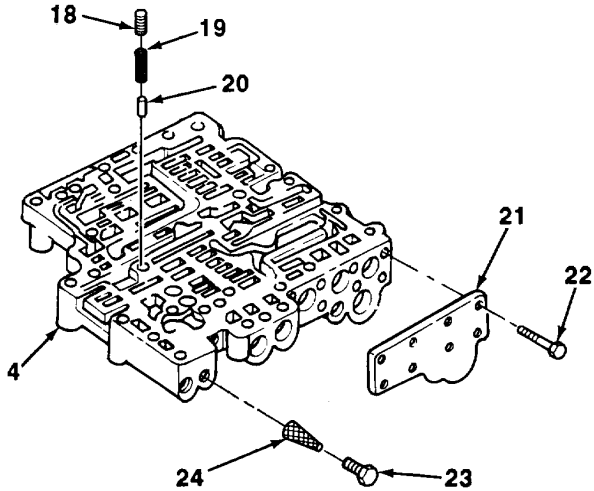

TA703882

6-34. CONTROL VALVE REPAIR (Con't).

- 20. Install lubrication valve pin (13), lubrication valve (14), spring (15), and washer (16) in oil transfer plate (1).
- 21. Press downward on washer (16) and install pin (17).
- 22. Apply thin coat of grease to surface of seven balls (12) and install balls to oil transfer plate (1).

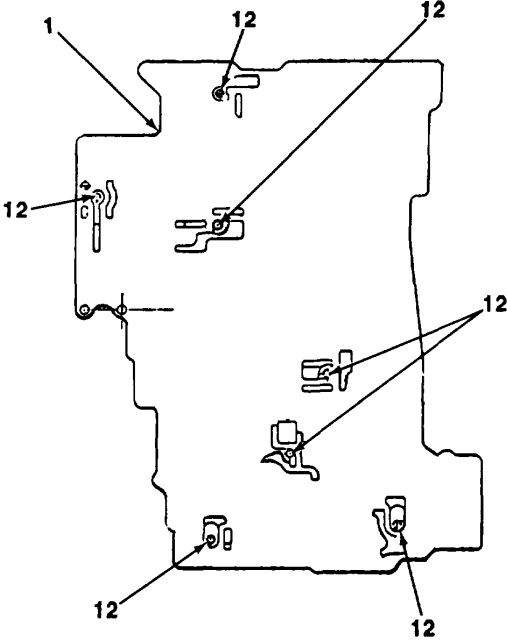
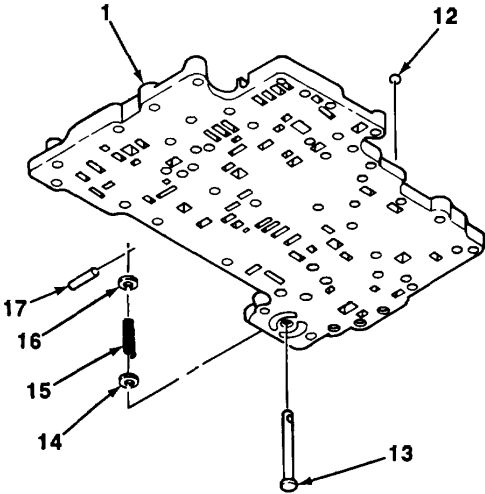

TA703883

6-34. CONTROL VALVE REPAIR (Con't).

23. Position separator plate (6) on oil transfer plate (1).

CAUTION

Do not allow separator plate and oil transfer plate to separate while handling. Balls in oil transfer plate may fall out of position and become damaged.

24. While holding separator plate (6) and oil transfer plate (1) together as an assembly, turn over and position on control valve body (4).

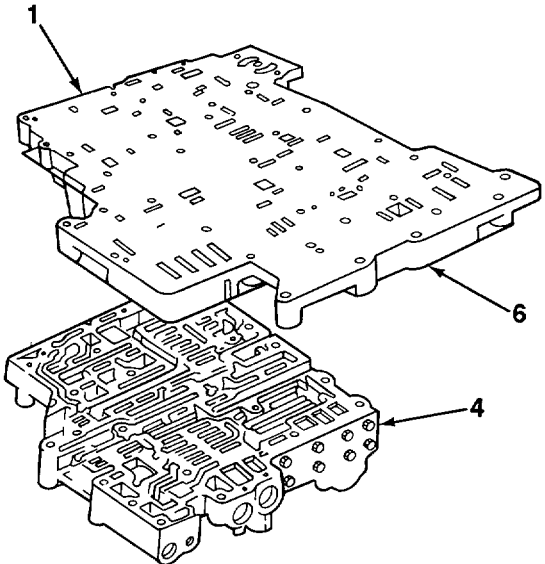
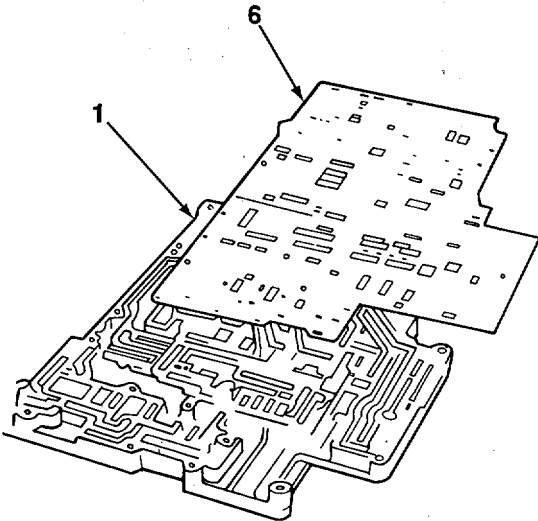

25. Install valve (7), spring ring pin (8), spring (9), washer (10), and spring ring (3) into modulator valve body (5). Press inward on spring ring and install retaining pin (11).

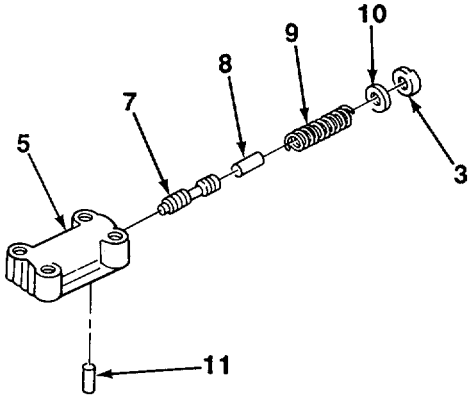

TA703884

6-34. CONTROL VALVE REPAIR (Con't).

26. Install modulator valve body (5) to oil transfer plate (1) with three screws (2). Do not fully tighten screws.
27. Aline bolt holes in oil transfer plate (1), separator plate (6) and control valve body (4).
28. Torque three screws (2) of modulator valve body (5) to 9-11 lb.-ft. (12-15 N-m).

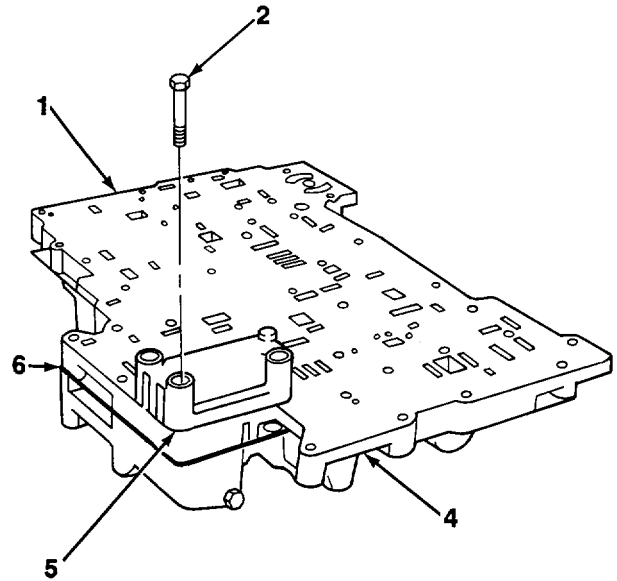
**FOLLOW-ON TASKS:**

- Install control valve (see paragraph 6-14).

TA703885

6-35. GOVERNOR ASSEMBLY REPLACEMENT.

This Task Covers:

a. Removal

b. Installation

Materials/Parts:

a One Gasket

Tools/Test Equipment:

- General mechanic's tool kit
 - Field automotive shop set
-

a. REMOVAL

1. Remove four bolts (1), cover (2), and gasket (3) from output housing (5). Discard gasket.
2. Remove governor (4) by turning clockwise.

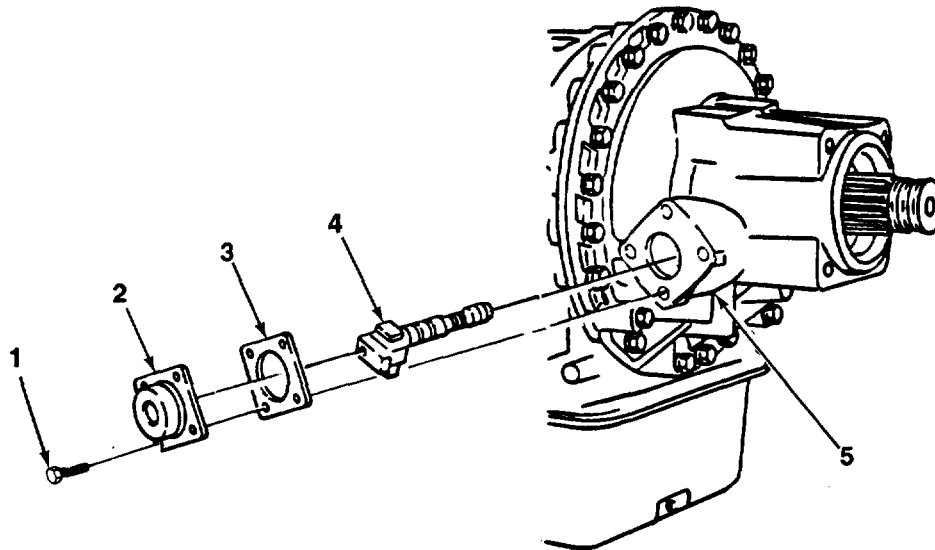
**b. INSTALLATION I**

1. Install governor (4) by turning counterclockwise.
2. Install new gasket (3) and cover (2) with four bolts (1). Torque bolts to 10-13 lb.-ft. (14-18 Nom).

TA703886

6-36. TRANSMISSION OUTPUT SHAFT OIL SEAL REPLACEMENT.

This Task Covers:

a. Removal

b. Installation

Initial Setup:

Equipment Conditions:

- Propeller shaft removed (see paragraph 7-1).

Tools/Test Equipment:

- General mechanic's tool kit
- Field automotive shop set

Materials/Parts:

- Sealing compound (Item 19, Appendix B)
- One oil seal
- One packing retainer

a. REMOVAL

Using slide hammer and remover, remove packing retainer (3) and oil seal (2) from output housing (1). Discard packing retainer and oil seal.

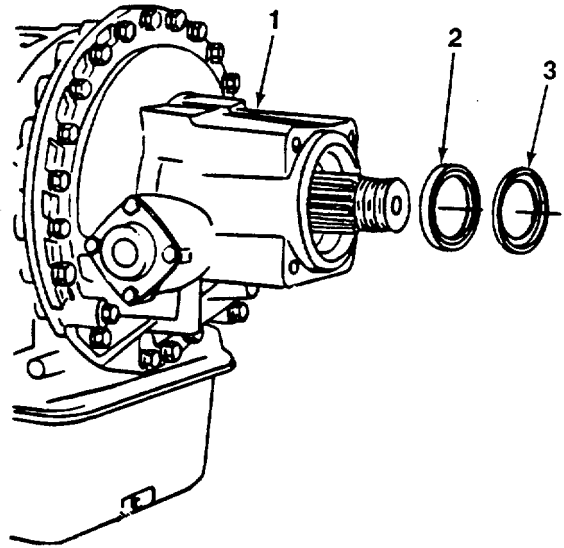
**b. INSTALLATION**

1. Apply thin coat of sealing compound to outer surface of new oil seal (2).
2. Install oil seal (2) with seal lip facing up.
3. Apply thin coat of sealing compound to outer surface of new packing retainer (3).
4. Install packing retainer (3), flat side first, in output housing (1).
5. Press packing retainer (3) until flush with 0.04 in. (1.02 mm) below surface of output housing (1).

FOLLOW-ON TASKS:

- Install propeller shaft (see paragraph 7-1).

TA703887

6-37. OUTPUT HOUSING REPAIR.

This Task Covers:

- a. Disassembly
- b. Cleaning and Inspection

- c. Assembly

Initial Setup:

Equipment Conditions:

- Output housing removed (see paragraph 6-19).
- Transmission output shaft oil seal removed (see paragraph 6-36).
- Governor assembly removed (see paragraph 6-35).

Tools/Test Equipment:

- General mechanic's tool kit
- Field automotive shop set
- Bar and stud
- Spring compressor

a. DISASSEMBLY

1. Remove snapping (1) from output housing (3).
2. Remove output shaft (2) and retaining ring (4).

Materials/Parts:

- Hydraulic fluid (Item 7, Appendix B)
- Grease (item 10, Appendix B)
- Sealing compound (Item 19, Appendix B)
- Dry cleaning solvent (Item 23, Appendix B)
- Two seals

General Safety Instructions:

- Dry cleaning solvent is flammable and must not be used near open flame. Use only in a well-ventilated area.

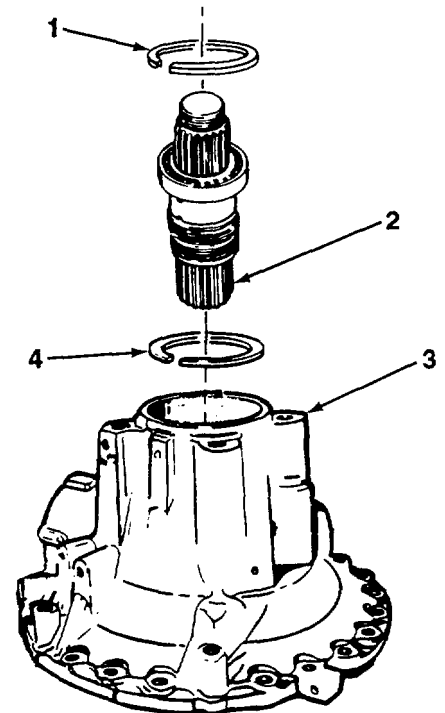

6-37. OUTPUT HOUSING REPAIR (Con't).

3. Support front surface of speedometer drive gear (7).
4. Press output shaft (2) downward to remove speedometer drive gear (7), spacer (6), and ball bearing (5).

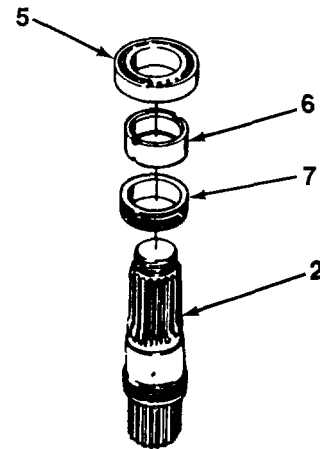

5. Turn output housing (3) with large flange facing upward.
6. Using bar and stud and spring compressor, compress clutch retainer (9) just enough to remove snapping (8). Remove bar and stud and spring compressor.

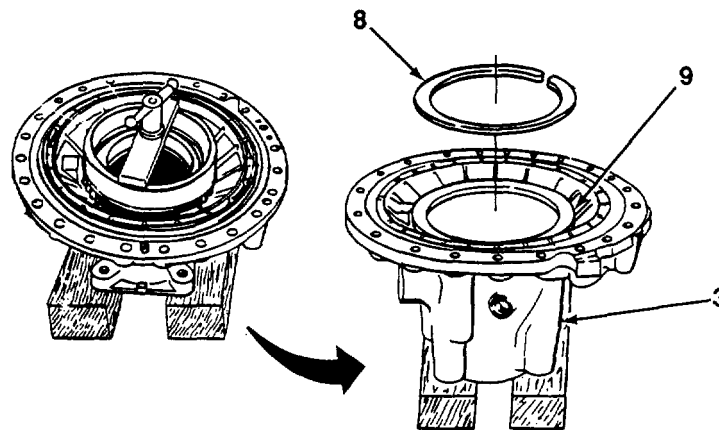

7. Remove clutch retainer (9) and 30 springs (10) from clutch piston (11).
8. Remove clutch piston (11) from output housing (3).
9. Remove two seals (12 and 13) from clutch piston (11). Discard seals.

TA703889

6-37. OUTPUT HOUSING REPAIR (Con't).

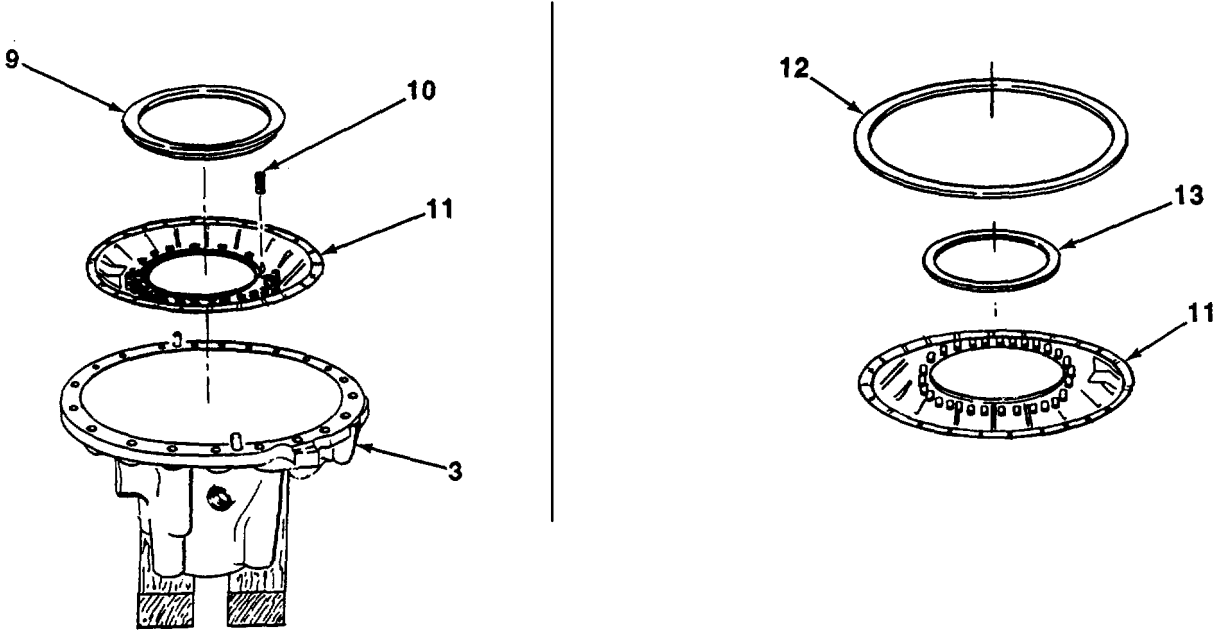

b. CLEANING AND INSPECTION

WARNING

Dry cleaning solvent, P-D-680, is toxic and flammable. Always wear protective goggles and gloves, and use only in a well-ventilated area. Avoid contact with skin, eyes, and clothes, and DO NOT breathe vapors. DO NOT use near open flame or excessive heat. The solvent's flash point is 100°F-138°F (38°C-59°C). If you become dizzy while using cleaning solvent, immediately get fresh air and medical help. If solvent contacts eyes, immediately wash your eyes and get medical aid.

- 1. Clean metal parts with dry cleaning solvent.
- 2. Inspect metal parts for cracks, breaks, wear, or other damage. Replace if damaged.
- 3. Inspect for broken or deformed springs. Springs must meet these requirements:

- (a) Length without load : 1.25 in. (3.18 cm).
- (b) Length with load of 17.9-18.9 lb (79.6-84 N):..... 0.88 in. (22.35 mm).

TA703890

6-37. OUTPUT HOUSING REPAIR (Con't).

4. Inspect dowel pins (14 and 15) for damage. Replace if damaged. Dowel pins must extend 0.36-0.40 in. (9.14-10.16 mm).
5. Inspect two pipe plugs (17) and plug (16) for damage. Replace if damaged.
6. Inspect bushing (19) in front of output shaft (2) for wear or damage. Replace if damaged. Clearance between main shaft (remaining in transmission) and inside diameter of bushing can be no greater than 0.004 in. (0.100 mm). Install new bushing to depth of 0.145-0.165 in. (3.683-4.191 mm).
7. Inspect plug (18) for damage. Replace if damaged.
8. Inspect governor gear pin. If damaged, replace governor gear pin.

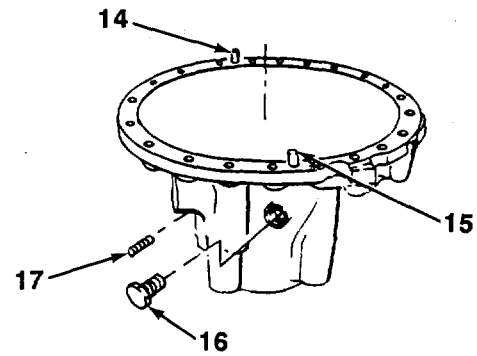

c. ASSEMBLY

1. Apply thin coat of hydraulic fluid to surface of new seals (12 and 13).
2. With spring pins of clutch piston (11) facing downward, install seals (12 and 13) to clutch piston with lips of both seals facing upward.

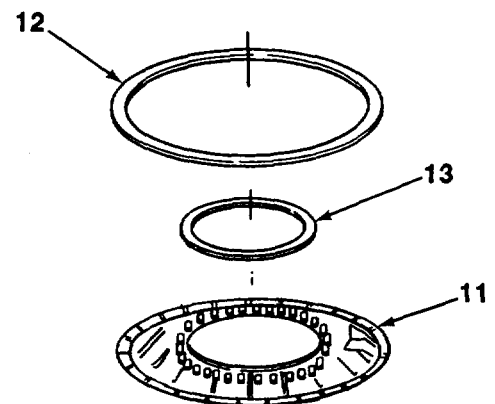
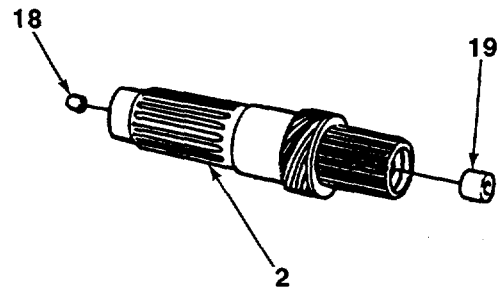

TA703891

6-37. OUTPUT HOUSING REPAIR (Con't).

3. Install clutch piston (11) into output housing (3).
4. Install 30 springs (10) and clutch retainer (9) on clutch piston (11).

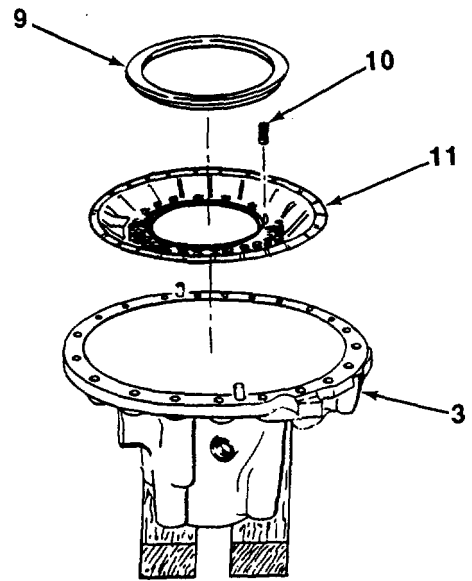

5. Using bar and stud and spring compressor, press clutch retainer (9) downward just enough to install snapping (8). Remove bar and stud and spring compressor.

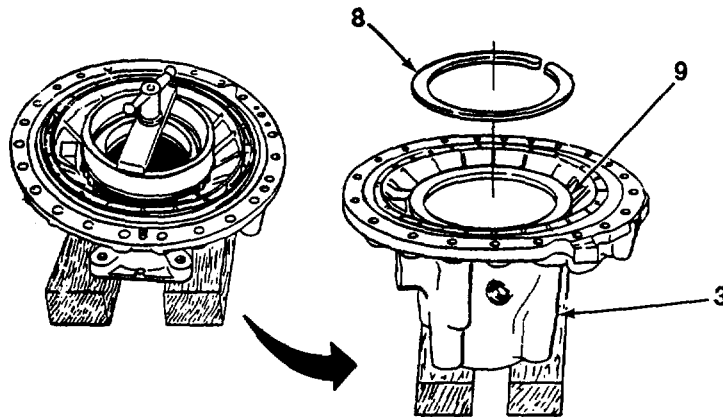

TA703892

6-37. OUTPUT HOUSING REPAIR (Con't).

6. Press speedometer drive gear (7), spacer (6), and ball bearing (5) on rear of output shaft (2).

7. Turn output housing (3) with large flange facing downward.

NOTE

If retaining ring is bevelled, install bevel toward rear of transmission.

8. Install retaining ring (4) into second groove of output housing (3).

9. Install output shaft (2) and snapping (1).

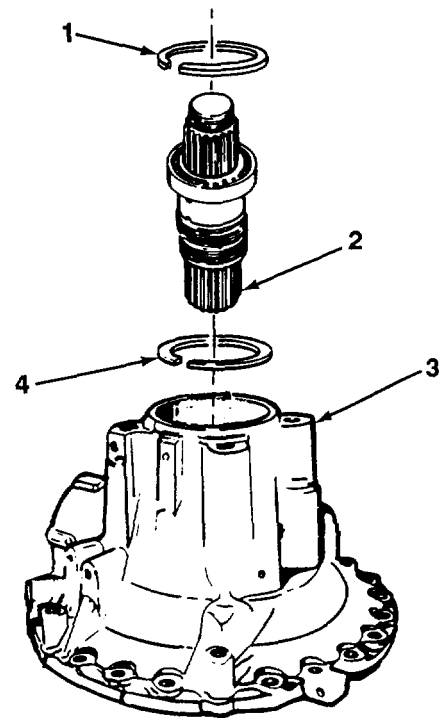
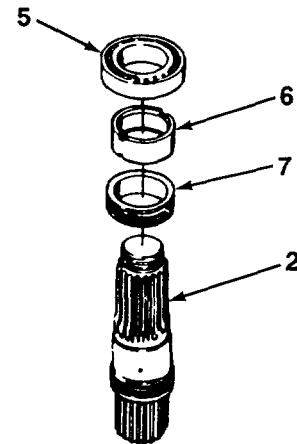
**FOLLOW-ON TASKS:**

- Install governor assembly (see paragraph 6-35).
- Install transmission output shaft oil seal (see paragraph 6-36).
- Install output housing (see paragraph 6-19).

TA703893

6-38. LOW PLANETARY CARRIER REPAIR.

This Task Covers:

- a. Disassembly
- b. Cleaning and Inspection

c. Assembly

Initial Setup:

Equipment Conditions:

* Low planetary carrier removed (see paragraph 6-20).

Tools/Test Equipment:

- General mechanic's tool kit
- Field automotive shop set

References:

be used near open flame. Use only in a well-ventilated area.

- TM 9-214

Materials/Parts:

- Hydraulic fluid (Item 7, Appendix B)
- Dry cleaning solvent (Item 23, Appendix B)
- Four pinion pins

General Safety Instructions:

* Dry cleaning solvent is flammable and must not

area.

a. DISASSEMBLY

1. Remove ball bearing (1) from low planetary carrier (2).

NOTE

Disassembly of low planetary carrier is required only if obvious wear or damage is evident.

2. Using drill bit, center drill bit over one end of each of four pinion pins (3).
3. Drill downward into each pinion pin (3) until swaged end of each pinion pin is weakened for removal. Ensure that metal of low planetary carrier (2) is not removed.

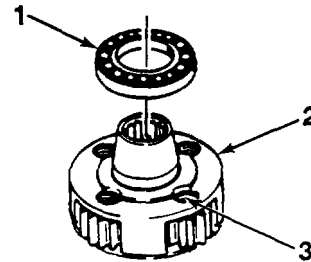

TA703894

6-38. LOW PLANETARY CARRIER REPAIR (Con't).**NOTE**

As each pinion pin is removed, keep pinion gear and four bearing washers together as a set.

4. Press four pinion pins (3) from low planetary carrier (2). Remove four pinion gears (6), eight steel bearing washers (4), and eight bronze bearing washers (5). Discard pinion pins.
5. Remove roller bearing (7) from each of four pinion gears (6).

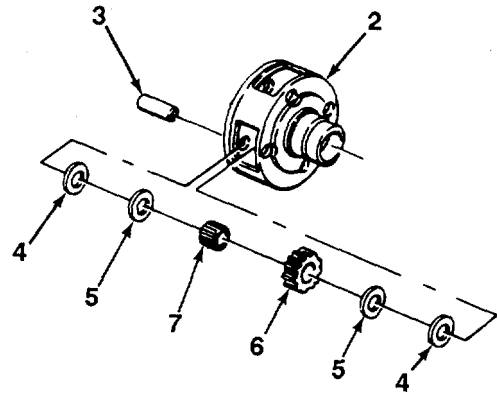
**b. CLEANING AND INSPECTION****WARNING**

Dry cleaning solvent, P-D-680, is toxic and flammable. Always wear protective goggles and gloves, and use only in a well-ventilated area. Avoid contact with skin, eyes, and clothes, and DO NOT breathe vapors. DO NOT use near open flame or excessive heat. The solvent's flash point is 100°F-138°F (38°C-59°C). If you become dizzy while using cleaning solvent, immediately get fresh air and medical help. If solvent contacts eyes, immediately wash your eyes and get medical aid.

1. Clean metal parts with dry cleaning solvent.

NOTE

Pinion gears are a matched set. If any pinion gear needs replacing, all must be replaced.

2. Inspect metal parts for cracks, breaks, wear, or other damage. Replace if damaged.
3. Inspect four roller bearings and ball bearing for wear or damage (see TM 9-214). Replace if damaged.

c. ASSEMBLY

1. Apply thin coat of hydraulic fluid to surface of all metal parts.
2. Install roller bearing (7) into each of four pinion gears (6).

NOTE

For easier assembly, pinion pins may be cooled and low planetary carrier may be heated.

3. Position one pinion gear (6), two steel bearing washers (4), and two bronze bearing washers (5) into low planetary carrier (2) and press in one new pinion pin (3). Install end of pinion pin 0.51-0.52 in. (12.95-13.21 mm) from front surface of low planetary carrier.

TA703895

6-38. LOW PLANETARY CARRIER REPAIR (Con't).

4. While supporting pinion pin (3) on 0.81 in. (20.57 mm) diameter anvil, swage each end of pinion pin, in eight places, using suitable punch. After swaging, pinion gear (6) must freely rotate.
5. Measure end play of pinion gear (6) on pinion pin (3). End play must be 0.008-0.031 in. (0.203-0.787 mm).
6. Repeat steps 3 through 5 for three remaining pinion gears (6).
7. Press ball bearing (1) on low planetary carrier (2).

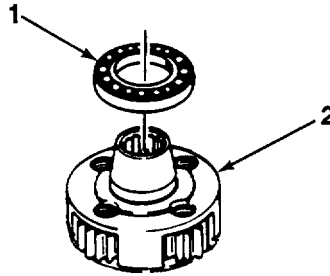
**FOLLOW-ON TASKS:**

- Install low planetary carrier (see paragraph 6-20).

TA703896

6-39. ADAPTER HOUSING REPAIR.

This Task Covers:

- a. Disassembly
- b. Cleaning and Inspection

c. Assembly

Initial Setup:

Equipment Conditions:

- Adapter housing removed (see paragraph 6-22).

Tools/Test Equipment:

- General mechanic's tool kit
- Field automotive shop set
- Installer

General Safety Instructions:

- Dry cleaning solvent is flammable and must not be used near open flame. Use only in a well-ventilated area.
-

Materials/Parts:

- Hydraulic fluid (Item 7, Appendix B)
- Dry cleaning solvent (Item 23, Appendix B)
- Two seals
- Four push-on nuts

a. DISASSEMBLY

1. Remove first clutch piston (1) assembly from adapter housing (2).

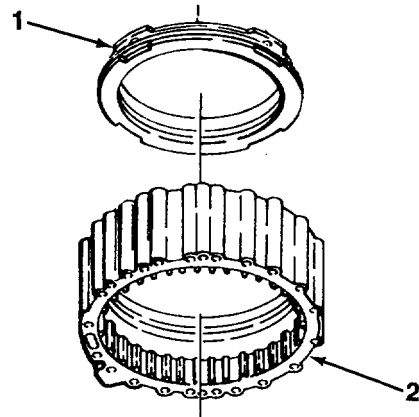

TA703897

6-39. ADAPTER HOUSING REPAIR (Con't).

- 2. Remove inner seal (6) and outer seal (7) from first clutch piston (1). Discard seals.

CAUTION

Push-on nuts must be cut off when removing. Any other method of removing will lessen the holding power of spring retainer during assembly.

- 3. Cut four push-on nuts (3) off pins of first clutch piston (1).
- 4. Remove spring retainer (4) and 28 springs (5).

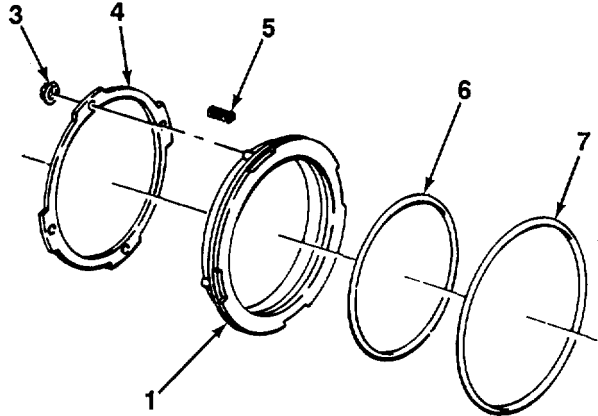

b. CLEANING AND INSPECTION I

WARNING

Dry cleaning solvent, P-D-680, is toxic and flammable. Always wear protective goggles and gloves, and use only in a well-ventilated area. Avoid contact with skin, eyes, and clothes, and DO NOT breathe vapors. DO NOT use near open flame or excessive heat. The solvent's flash point is 100°F-138°F (38°C-59°C). If you become dizzy while using cleaning solvent, immediately get fresh air and medical help. If solvent contacts eyes, immediately wash your eyes and get medical aid.

- 1. Clean metal parts with dry cleaning solvent.
- 2. Inspect metal parts for cracks, breaks, wear, and other damage. Replace damaged parts.
- 3. Inspect for broken or deformed springs. Springs must meet following requirements:
 - (a) Length without load:..... 1.29 in. (3.28 cm mm).
 - (b) Length with load of 4.3-5.7 lb. (19.13-25.35 N):0.82 in. (20.83 mm).

- 4. Inspect dowel pins (8 and 9) in adapter housing (2) for damage. Replace if damaged. Dowel pins must extend 0.36-0.40 in. (9.14-10.16 mm).
- 5. Inspect plug (10) in adapter housing (2). Replace if damaged. Install plug flush with, or to 0.06 in. (1.52 mm) below front surface of adapter housing.

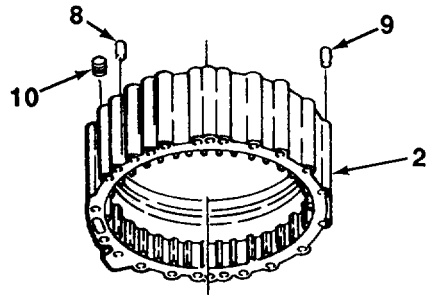

TA703898

6-39. ADAPTER HOUSING REPAIR (Con't).

c. ASSEMBLY

- 1. Using adapter housing (2) to hold first clutch piston (1), place first clutch piston into adapter housing until fully seated.
- 2. Install 28 springs (5) into recesses of first clutch piston (1).
- 3. Install spring retainer (4) over springs (5) with flanges of spring retainer facing upward.

CAUTION

Failure to install push-on nuts to proper location may result in damage to transmission. If installed too far, clutch will have improper clearance. If not installed far enough, push-on nuts may fall off.

- 4. Using installer, install four new push-on nuts (3). Press downward until spring retainer (4) flange bottoms in recess of adapter housing (2).
- 5. Remove first clutch piston (1) from adapter housing (2).

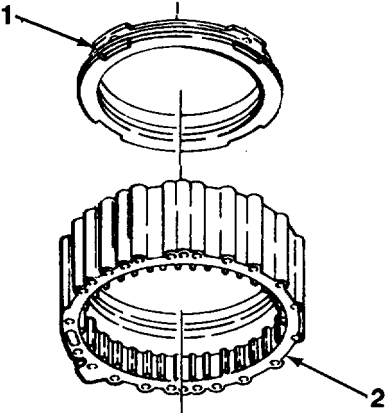
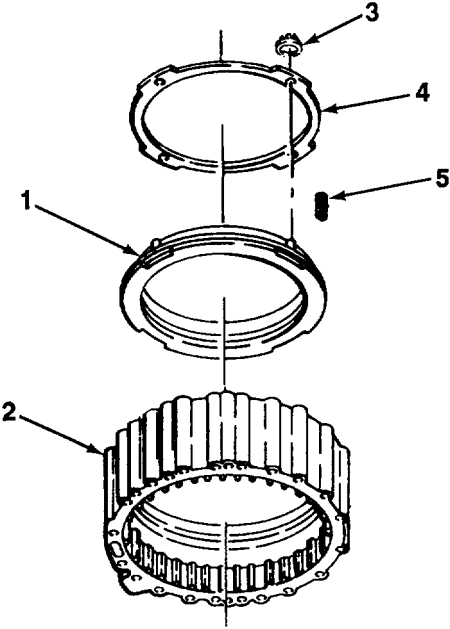

6-39. ADAPTER HOUSING REPAIR (Con't).

6. Apply thin coat of hydraulic fluid to surface of new inner seal (6) and new outer seal (7).
7. With spring side of first clutch piston (1) facing downward, install inner seal (6) and outer seal (7) to first clutch piston with lips of both seals facing upward.
8. Install first clutch piston (1) assembly to adapter housing (2).

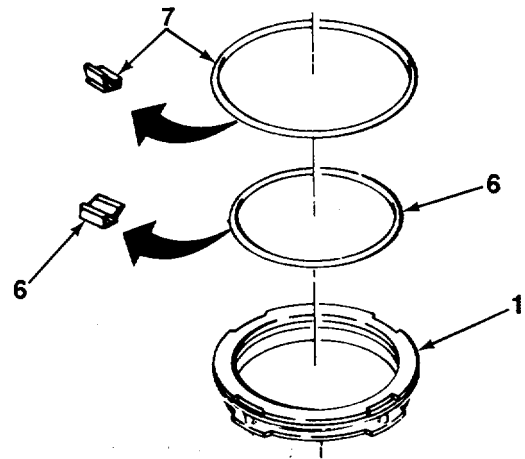
**FOLLOW-ON TASKS:**

- Install adapter housing (see paragraph 6-22).

TA703900

6-40. GEAR UNIT REPAIR.

This Task Covers:

- a. Disassembly
- b. Cleaning and Inspection

- c. Assembly

Initial Setup:

Equipment Conditions:

- Gear unit removed (see paragraph 6-25).

Tools/Test Equipment:

- General mechanic's tool kit
- Field automotive shop set
- Plug installer

General Safety Instructions:

- Dry cleaning solvent is flammable and must not be used near open flame. Use only in a well-ventilated area.

Materials/Parts:

- Hydraulic fluid (Item 7, Appendix B)
- Grease (Item 10, Appendix B)
- Sealing compound (Item 19, Appendix B)
- Dry cleaning solvent (Item 23, Appendix B)
- Fourteen pinion pins

a. ASSEMBLY

1. Remove bearing washer (1), spur gear (2), and bearing washer (3) from sun gearshaft (6).
2. Remove front planetary carrier (4) and bearing washer (5) from planetary drum (7).

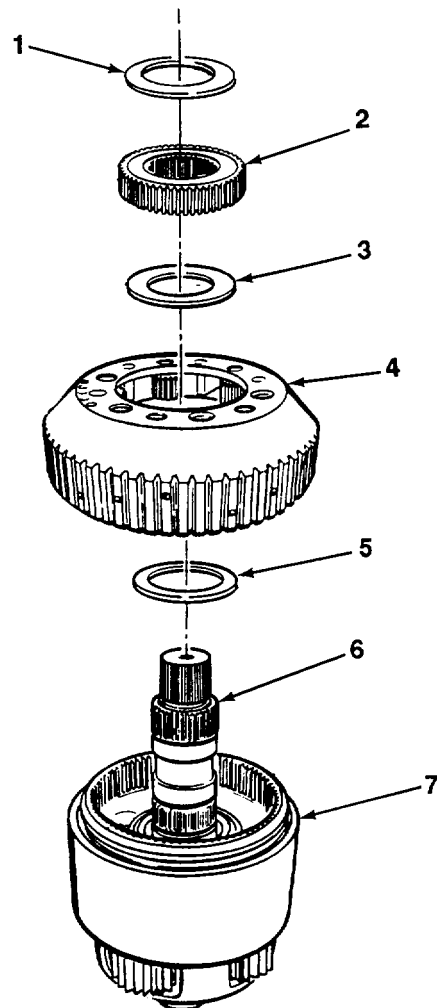

TA703901

6-40. GEAR UNIT REPAIR (Con't).

NOTE

- Disassembly of front planetary carrier is required only if obvious wear or damage is evident.
- Perform steps 3 through 6 to disassemble FRONT planetary carrier.

3. Using X in. drill bit, center drill bit over one end of each of six pinion pins (8).
4. Drill downward into each pinion pin (8) until swaged end of each pinion pin is weakened for removal. Ensure that metal of front planetary carrier (4) is not removed.

NOTE

As each pinion pin is removed, keep pinion gear, two bearing washers, and two bearing seats together as a set.

5. Press six pinion pins (8) from front planetary carrier (4). Remove six pinion gears (11), 12 bearing washers (9), and 12 bearing seats (10). Discard pinion pins.
 6. Remove one cone (12) from each of six pinion gears (11).
7. Remove sun gearshaft (6) and thrust washer (13) from main shaft (16).
 8. Remove large retaining ring (14) and ring gear (15) from planetary drum (7).

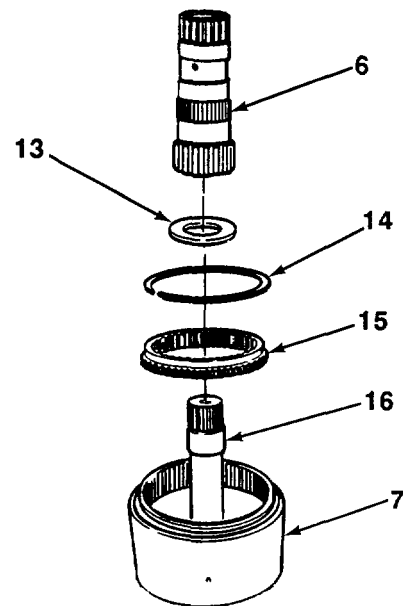
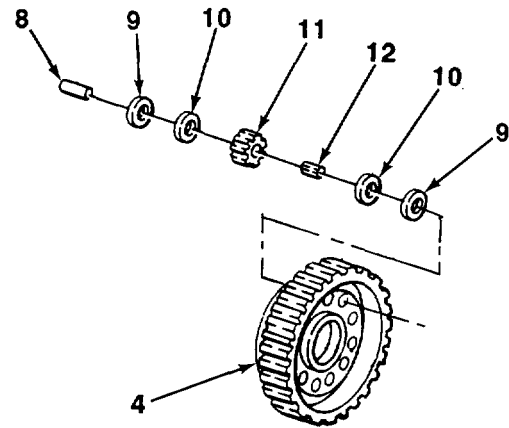

TA703902

6-40. GEAR UNIT REPAIR (Con't).

9. Remove center planetary carrier (17) from planetary drum (7).

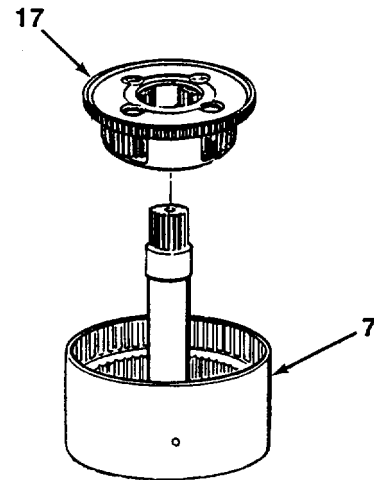

NOTE

- Disassembly of center planetary carrier is required only if obvious wear or damage is evident.
- Perform steps 10 through 13 to disassemble CENTER planetary carrier.

10. Using 3X2 in. drill bit, center drill bit over one end of each of four pinion pins (18).
11. Drill downward into each pinion pin (18) until swaged end of each pinion pin is weakened for removal. Ensure that metal of center planetary carrier (17) is not removed.

NOTE

As each pinion pin is removed, keep pinion gear and four thrustwashers together as a set.

12. Press four pinion pins (18) from center planetary carrier (17). Remove four gears (22), eight steel thrustwashers (19), and eight bronze thrustwashers (20). Discard pinion pins.
13. Remove two roller bearings (21) from each of four pinion gears (22).

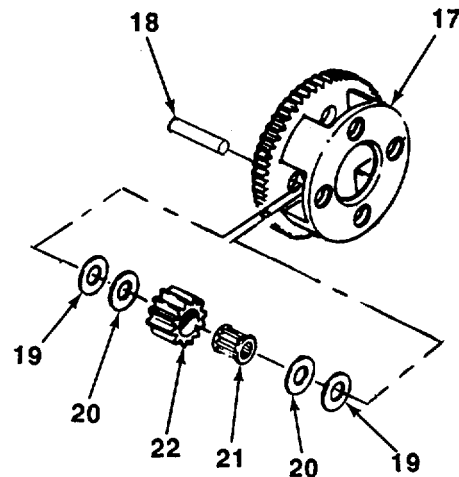

TA703903

6-40. GEAR UNIT REPAIR (Con't).

14. Remove snapping (23) and low sun gear (24) from end of main shaft (16).
15. Remove bearing race (25), roller bearing (26), and bearing race (27).
16. Remove main shaft (16) and center planetary ring gear (28) from planetary drum (7).

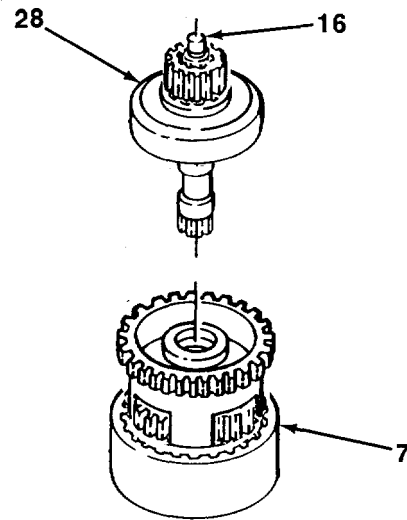
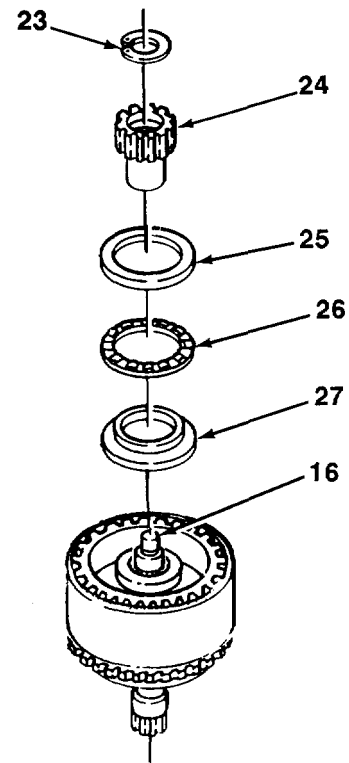

TA703904

6-40. GEAR UNIT REPAIR (Con't).

- 17. Remove snapping (33) from sun gear (29).
- 18. Remove sun gear (29) and main shaft (16) from center planetary ring gear (28).
- 19. Remove bearing race (30), roller bearing (31), and bearing race (32) from center planetary ring gear (28).

- 20. Remove snapping (34) and remove rear planetary carrier (35) from planetary drum (7).

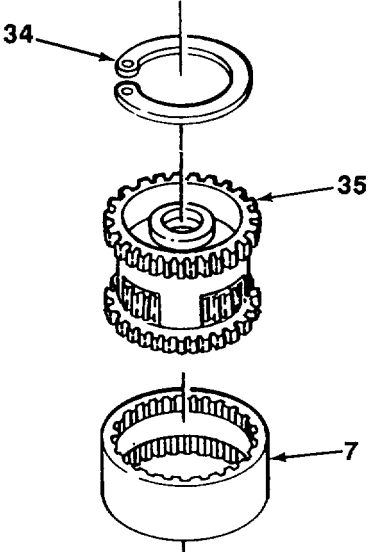
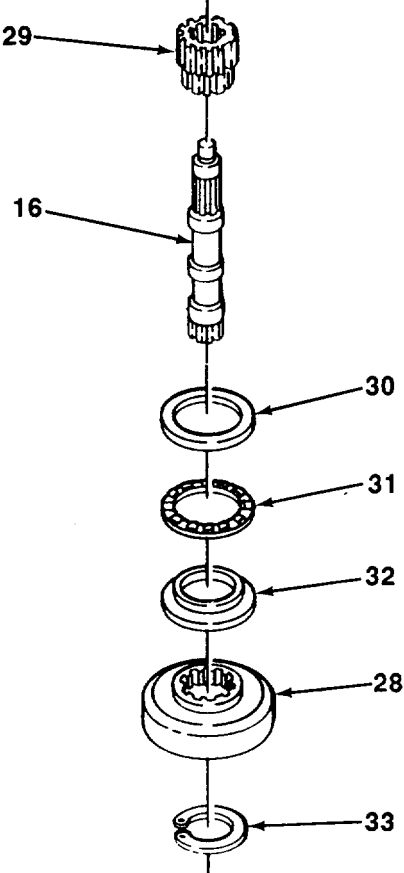

TA703905

6-40. GEAR UNIT REPAIR (Con't).**NOTE**

- Disassembly of rear planetary carrier is required only if obvious wear or damage is evident.
- Perform steps 21 through 24 to disassemble REAR planetary carrier.

21. Using 3X2 in. drill bit, center drill bit over one end of each of four planetary pins (40).
22. Drill downward into each planetary pin (40) until swaged end of each planetary pin is weakened for removal. Ensure that metal of rear planetary carrier (35) is not removed.

NOTE

As each pinion pin is removed, keep pinion gear and four thrustwashers together as a set.

23. Press four planetary pins (40) from rear planetary carrier (35). Remove four pinion gears (38), eight steel thrustwashers (36), and eight bronze thrustwashers (37). Discard planetary pins.
24. Remove roller bearing (39) from each of four pinion gears (38).

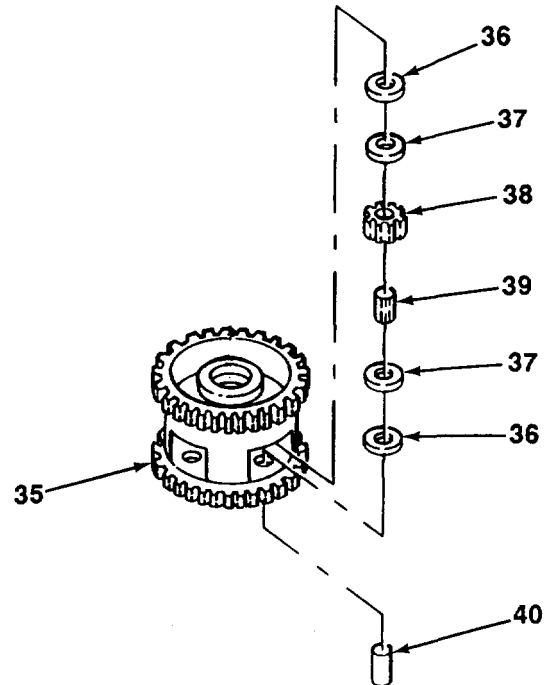
**b. CLEANING AND INSPECTION****WARNING**

Dry cleaning solvent, P-D-680, is toxic and flammable. Always wear protective goggles and gloves, and use only in a well-ventilated area. Avoid contact with skin, eyes, and clothes, and DO NOT breathe vapors. DO NOT use near open flame or excessive heat. The solvent's flash point is 1000F-1380F (380C-590C). If you become dizzy while using cleaning solvent, immediately get fresh air and medical help. If solvent contacts eyes, immediately wash your eyes and get medical aid. 1. Clean metal parts with dry cleaning solvent.

NOTE

Pinion gears are a matched set. If any pinion gear needs replacing, all in set must be replaced.

2. Inspect metal parts for cracks, breaks, wear, and other damage. Replace if damaged.
3. Inspect roller bearings for wear or damage. Replace if damaged.

TA703906

6-40. GEAR UNIT REPAIR (Con't).

4. Inspect bushing (41) in rear planetary carrier (35). If worn or damaged, replace rear planetary carrier.
5. Measure inside diameter of two bushings (42) in sun gearshaft (6). Measure diameter of main shaft at two places that contact bushings. Clearance must be no greater than 0.064 in. (0.163 mm).
6. Measure thickness of three bearing washers (1, 3, and 5) and thrustwasher (13). Thickness of each must be no less than 0.083 in. (2.108 mm).
7. Measure inside diameter of bushing in center support (see paragraph 6-41). Measure outside diameter of sun gearshaft (6) that contacts bushing. Clearance must be no greater than 0.065 in. (1.651 mm).

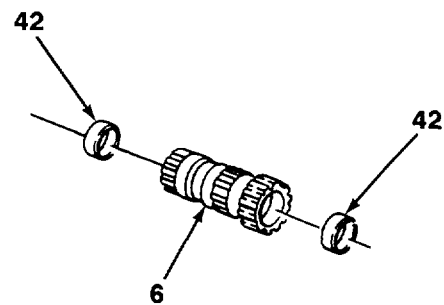
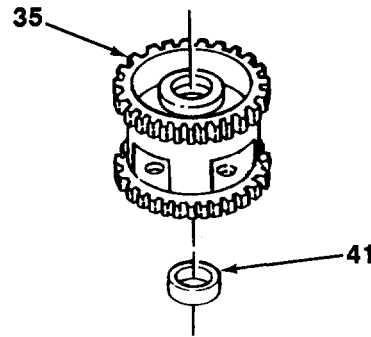

8. Inspect bushing sleeve (43) in front planetary carrier (4). If worn or damaged, replace front planetary carrier.
9. Measure inside diameter of bushing sleeve (43) in front planetary carrier (4). Measure outside diameter of sun gearshaft (6) that contacts bushing. Clearance must be no greater than 0.0072 in. (0.1829 mm).

TA703907

6-40. GEAR UNIT REPAIR (Con't).

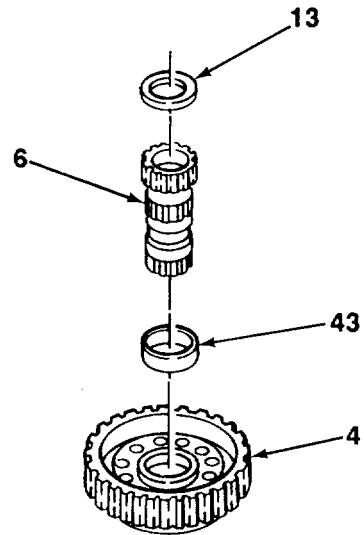
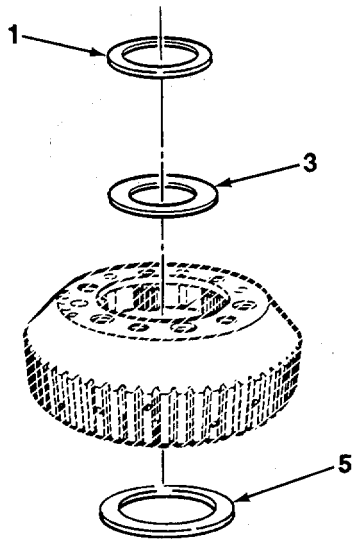

10. Inspect plug (44) in end of main shaft (16) for damage. Replace if damaged.

NOTE

Perform steps 11 through 13 to replace plug in end of main shaft.

11. Remove plug (44) from end of main shaft (16). Discard plug.
12. Apply thin coat of sealing compound to outside surface of new plug (44).
13. Using installer, press plug (44) into main shaft (16).

C. ASSEMBLY

1. Apply thin coat of hydraulic fluid to surface of all metal parts.

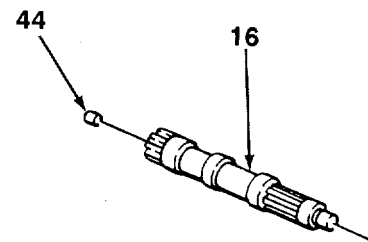

TA703908

6-40. GEAR UNIT REPAIR (Con't).

NOTE

Perform steps 2 through 6 to assemble REAR planetary carrier.

2. Install roller bearing (39) into each of four pinion gears (38).

NOTE

For easier assembly, planetary pins may be cooled and rear planetary carrier may be heated.

3. Position one pinion gear (38), two steel washers (36), and two bronze washers (37) into rear planetary carrier (35) and press in one new planetary pin (40). Install end of pinion pin to 0.47-0.48 in. (11.938-12.192 mm).
4. While supporting planetary pin (40) on 0.812 in. (20.625 mm) diameter anvil, swage each end of pinion pin in eight places using suitable punch. After swaging, pinion gear (38) must freely rotate.
5. Measure end play of pinion gear (38) on planetary pin (40). End play must be 0.008-0.031 in. (0.203-0.787 mm).
6. Repeat steps 3 through 5 for three remaining pinion gears (38).

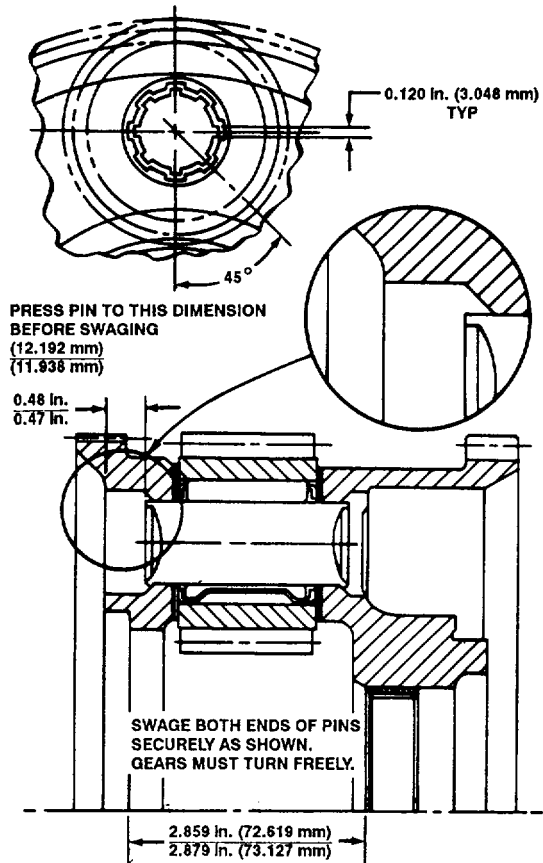
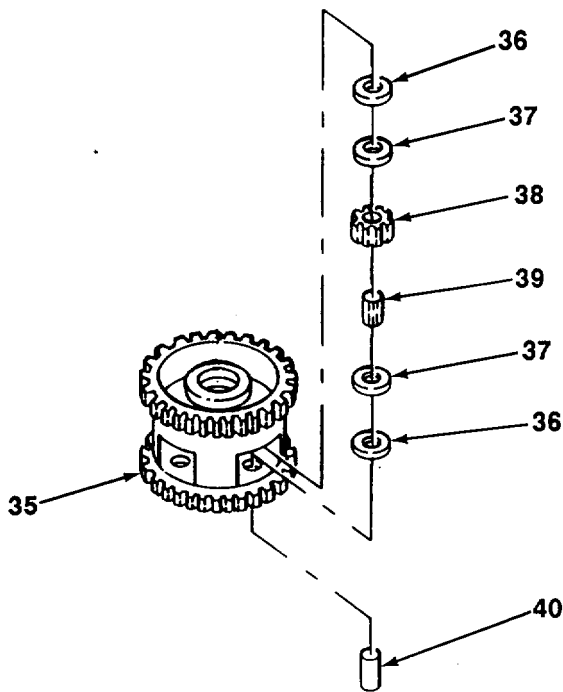

TA703909

6-40. GEAR UNIT REPAIR (Con't).

NOTE

Perform steps 7 through 10 to assemble CENTER planetary carrier.

7. Install two roller bearings (21) into each of four pinion gears (22).

NOTE

For easier assembly, pinion pins may be cooled and center planetary carrier may be heated.

8. Position one pinion gear (22), two steel thrustwashers (19), and two bronze thrustwashers (20) into center planetary carrier (17) and press in one new pinion pin (18). Install end of pinion pin to 0.075-0.085 in. (1.905-2.159 mm).

9. While supporting pinion pin (18) on 0.812 in. (20.625 mm) diameter anvil, swage each end of pinion pin in eight places using suitable punch. After swaging, pinion gear (22) must freely rotate.

10. Repeat steps 8 and 9 for three remaining pinion gears (22).

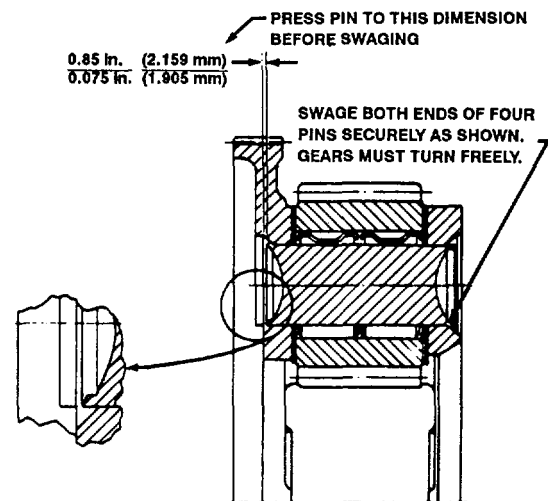
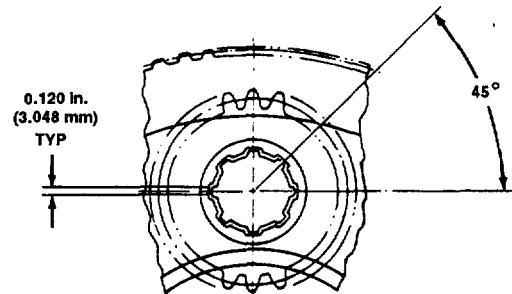
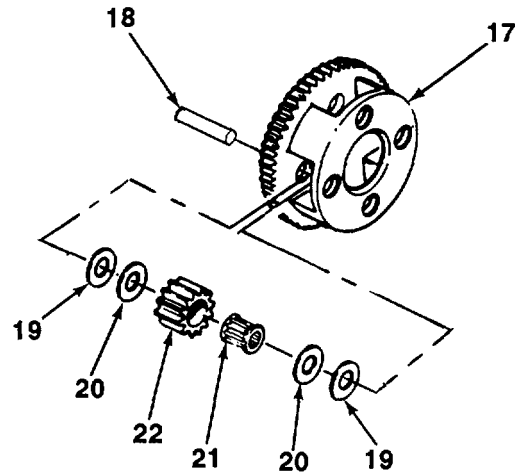

TA703910

6-40. GEAR UNIT REPAIR (Con't).

NOTE

Perform steps 11 through 14 to assemble FRONT planetary carrier.

- 11. Install cone (12) into each of six pinion gears (11).

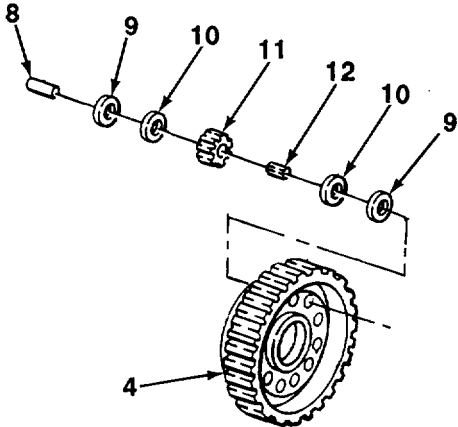

NOTE

For easier assembly, planetary pins may be cooled and front planetary carrier may be heated.

- 12. Position one pinion gear (11), two bearing washers (9), and two bearing seats (10) into front planetary carrier (4) and press in one new piston pin (8). Install end of pinion pin to 0.117-0.127 in. (2.97-3.3 mm).
- 13. While supporting pinion pin (8) on X in. (12.7 mm) diameter anvil, swage each end of pinion pin in eight places using suitable punch. After swaging, pinion gear (11) must freely rotate.
- 14. Repeat steps 12 and 13 for five remaining pinion gears (11).

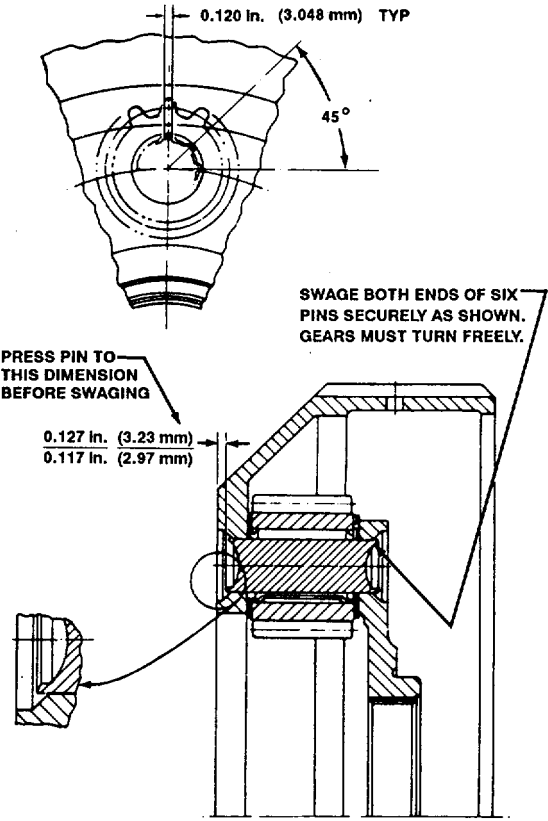

TA703911

6-40. GEAR UNIT REPAIR (Con't).

- 15. Install rear planetary carrier (35) into planetary drum (7) and install snapping (34).
- 16. Apply thin coat of grease to bearing race (32), roller bearing (31), and bearing race (30).
- 17. Install bearing race (32), flat side first, to rear of center planetary ring gear (28).
- 18. Install roller bearing (31) and bearing race (30) on center planetary ring gear (28).
- 19. Install sun gear (29) into rear of center planetary ring gear (28) and install snapping (33).
- 20. Install main shaft (16) through sun gear (29), smaller end first.

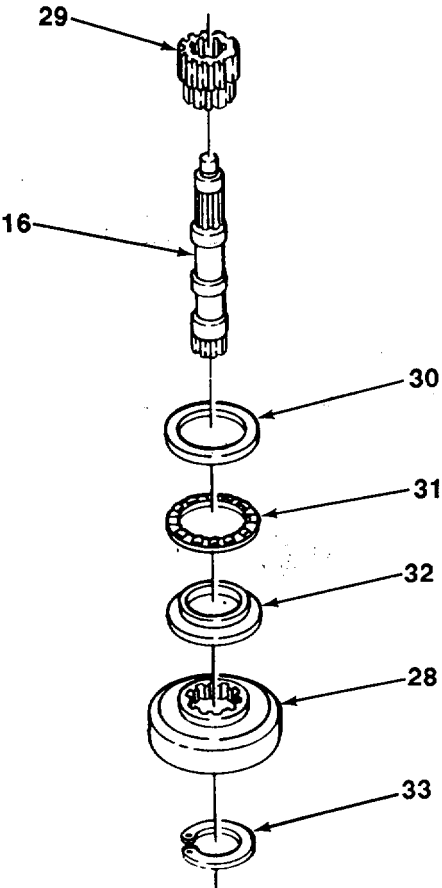
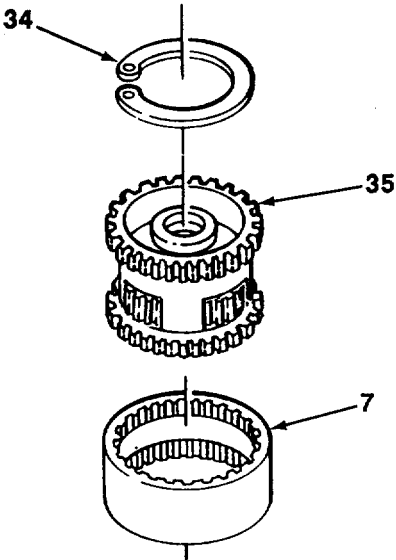

6-40. GEAR UNIT REPAIR (Con't).

NOTE

Ensure that bearing race on main shaft fully seats into recess of rear planetary carrier.

- 21. Install main shaft (16) and attached parts into planetary drum (7).
- 22. Apply thin coat of grease to bearing race (27), roller bearing (26), and bearing race (25).
- 23. Install bearing race (27), roller bearing (26), and bearing race (25) on end of main shaft (16).
- 24. Install low sun gear (24) over end of main shaft (16) and install snapping (23).

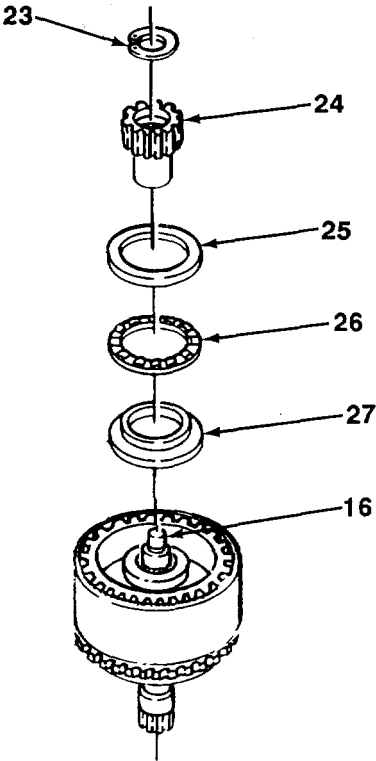
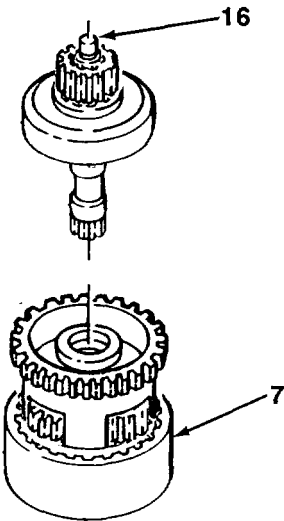

6-40. GEAR UNIT REPAIR (Con't).

25. With main shaft (16) facing upward, position center planetary carrier (17) assembly, with outer splines facing upward, over main shaft and install center planetary carrier into planetary drum (7).

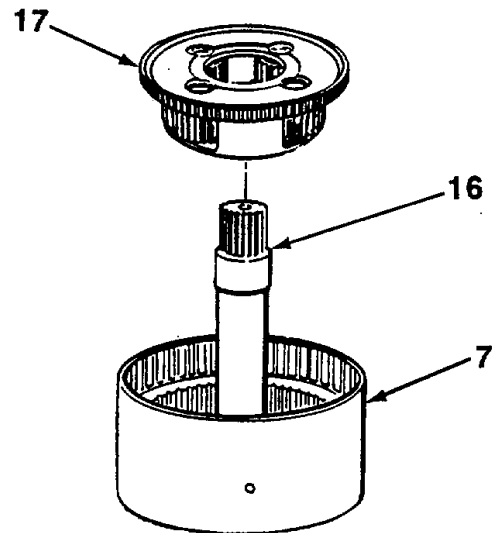

26. Install ring gear (15), with outer splines facing downward, into planetary drum (7) and install retaining ring (14).

27. Apply thin coat of grease to surface of thrustwasher (13).

28. Install thrustwasher (13) and sun gearshaft (6), with larger diameter facing downward, over main shaft (16).

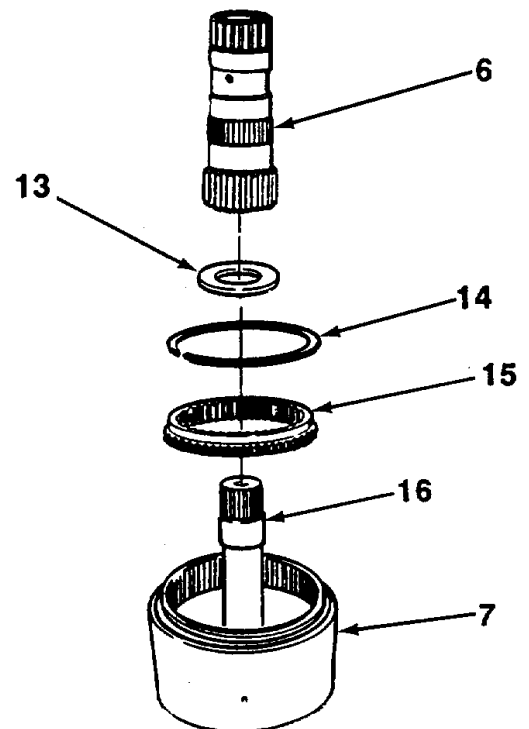

TA703914

6-40. GEAR UNIT REPAIR (Con't).

29. Apply thin coat of grease to surface of bearing washer (5).
30. Install bearing washer (5) to hub of front planetary carrier (4) assembly and install front planetary carrier.
31. Apply thin coat of grease to surface of bearing washers (1 and 3).
32. Install bearing washer (3), spur gear (2), and bearing washer (1) over sun gearshaft (6) and into planetary drum (7).

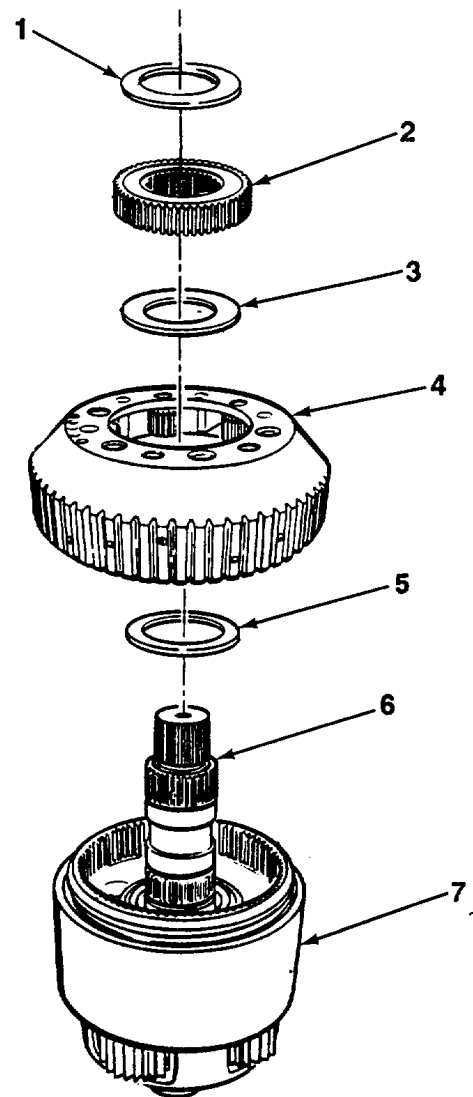
**FOLLOW-ON TASKS:**

- Install gear unit (see paragraph 6-25).

TA703915

6-41. CENTER SUPPORT REPAIR.

This Task Covers:

- a. Disassembly
- b. Cleaning and Inspection

- c. Assembly
-

*Initial Setup:***Equipment Conditions:**

- Center support removed (see paragraph 6-24).

Tools/Test Equipment:

- General mechanic's tool kit
- Field automotive shop set
- Installer

Materials/Parts:

- Hydraulic fluid (Item 7, Appendix B)
- Grease (Item 10, Appendix B)
- Dry cleaning solvent (Item 23, Appendix B)
- Two seal rings
- Four seals
- Eight push-on nuts

General Safety Instructions:

- Dry cleaning solvent is flammable and must not be used near open flame. Use only in a well-ventilated area.
-

a. DISASSEMBLY

1. Place center support (1) on work surface with hub of center support facing upward.
2. Remove two seal rings (2) from hub of center support (1). Discard seal rings.

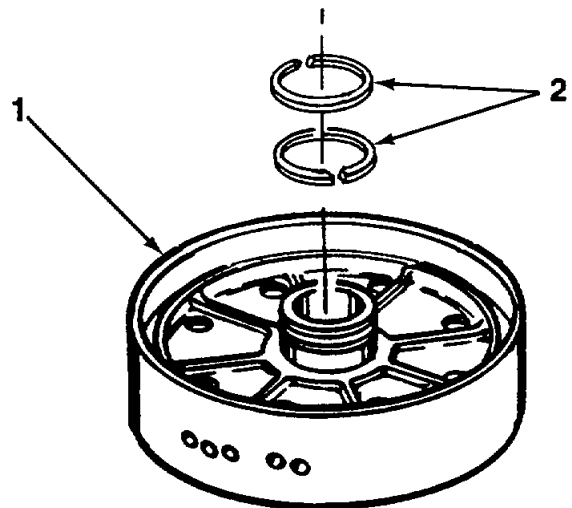

TA703916

6-41. CENTER SUPPORT REPAIR (Con't).

NOTE

Snapping Is one of four color marked snaprings that can be selected for installation.

3. Remove large snapping (3) from center support (1).
4. Remove piston (4) assembly.

5. Cut off four push-on nuts (5) and remove spring retainer (6) and 20 springs (7) from piston (4). Discard push-on nuts.

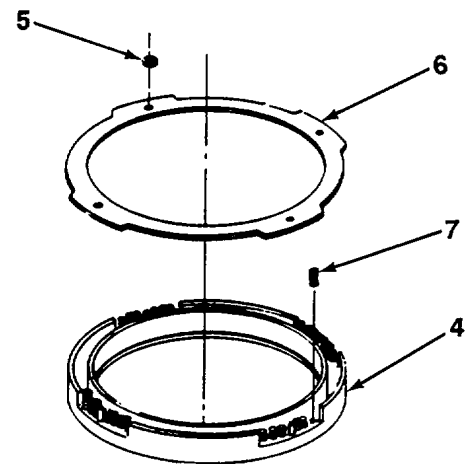
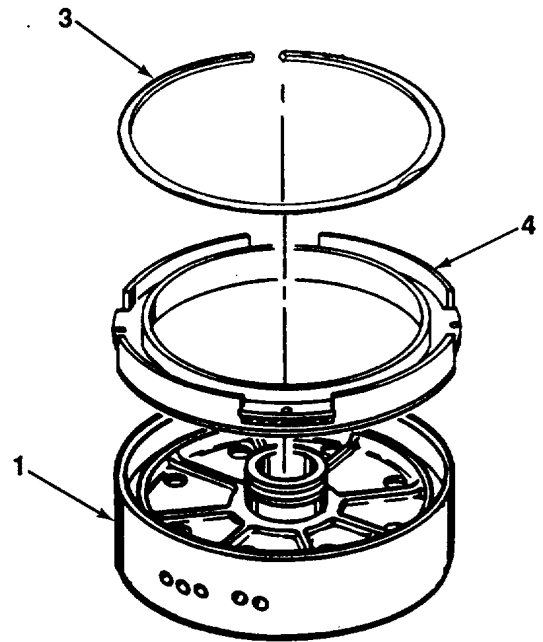

TA703917

6-41. CENTER SUPPORT REPAIR (Con't).

6. Remove seals (8 and 9) from piston (4). Discard seals.

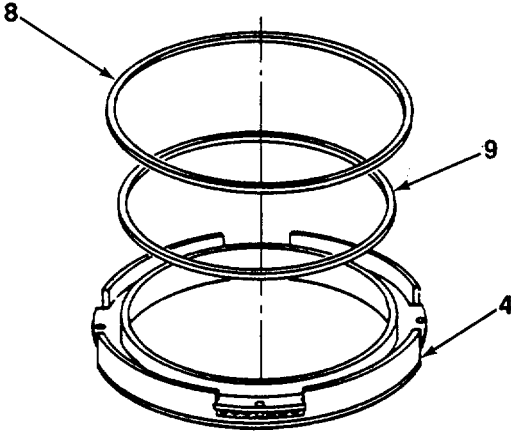

7. Turn center support (1) over and repeat steps 3 through 6 for other piston (4) assembly.

8. Remove roller bearing (10) and bearing race (11) from hub of center support (1).

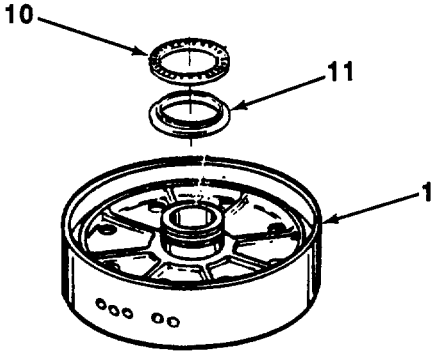

b. CLEANING AND INSPECTION

WARNING

Dry cleaning solvent, P-D-680, is toxic and flammable. Always wear protective goggles and gloves, and use only in a well-ventilated area. Avoid contact with skin, eyes, and clothes, and DO NOT breathe vapors. DO NOT use near open flame or excessive heat. The solvent's flash point is 1000F-1380F (380C-590C). If you become dizzy while using cleaning solvent, immediately get fresh air and medical help. If solvent contacts eyes, immediately wash your eyes and get medical aid.

- 1. Clean metal parts with dry cleaning solvent.
- 2. Inspect metal parts for cracks, breaks, wear, and other damage.
- 3. Inspect for broken or deformed springs. Springs must meet these requirements:
 - (a) Length without load:..... 1.29 in. (3.28 cm).
 - (b) Length with load of 4.3-5.7 lb. (19.13-25.35 N):.....0.82 in. (20.83 mm).

6-41. CENTER SUPPORT REPAIR (Con't).**c. ASSEMBLY**

1. Install bearing race (11) and roller bearing (10) on hub of center support (1).
2. Place center support (1) on work surface with hub of center support facing downward.
3. Using center support (1) to hold piston (4), place piston into center support until fully seated.
4. Install 20 springs (7) into recesses of piston (4).
5. Install spring retainer (6) over springs (7).
6. Using installer, install four new push-on nuts (5). Press downward until flange of spring retainer (6) bottoms in recess of center support (1).
7. Remove piston (4) from center support (1).
8. Turn center support (1) over and repeat steps 3 through 7 to assemble piston (4) on other side of center support.
9. Apply thin coat of hydraulic fluid to surface of center support (1).

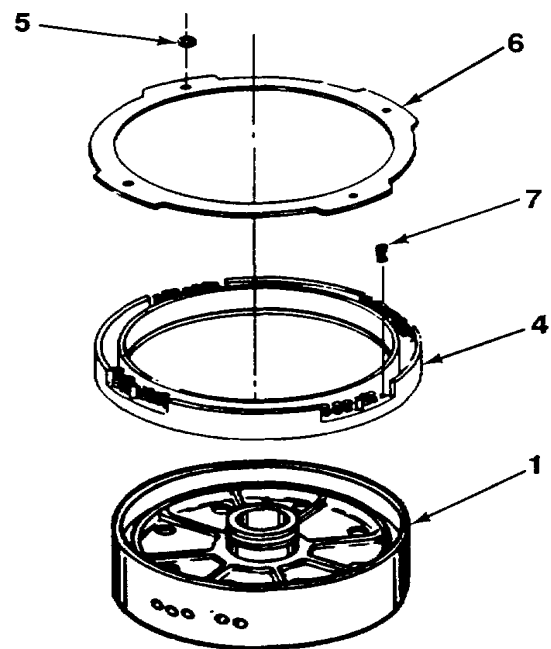
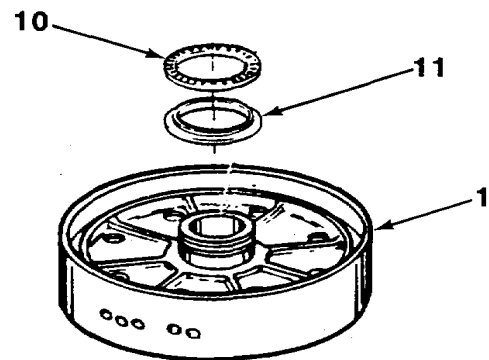

10. Apply thin coat of grease to new seals (8 and 9).
11. With spring side of piston (4) facing downward, install seals (8 and 9) with lips of seals facing upward.

TA703919

6-41. CENTER SUPPORT REPAIR (Con't).

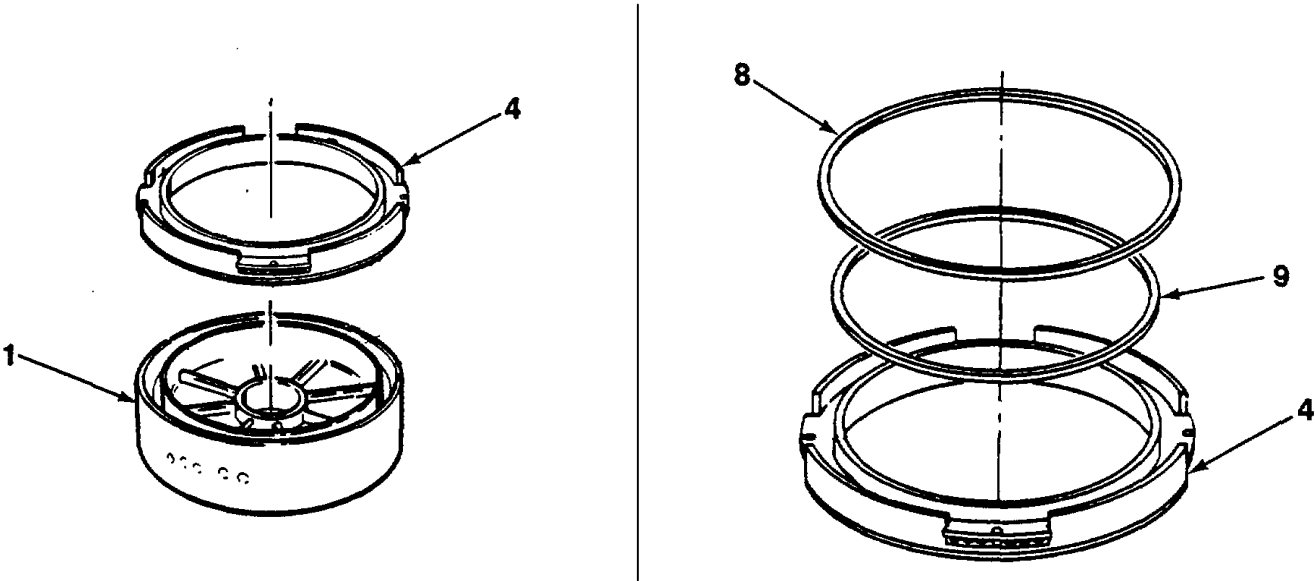

NOTE

Ensure that snapping is color marked same as one that was removed.

- 12. Install piston (4) assembly into center support (1) and install large snapping (3).
- 13. Turn center support (1) over and repeat steps 10 through 12.

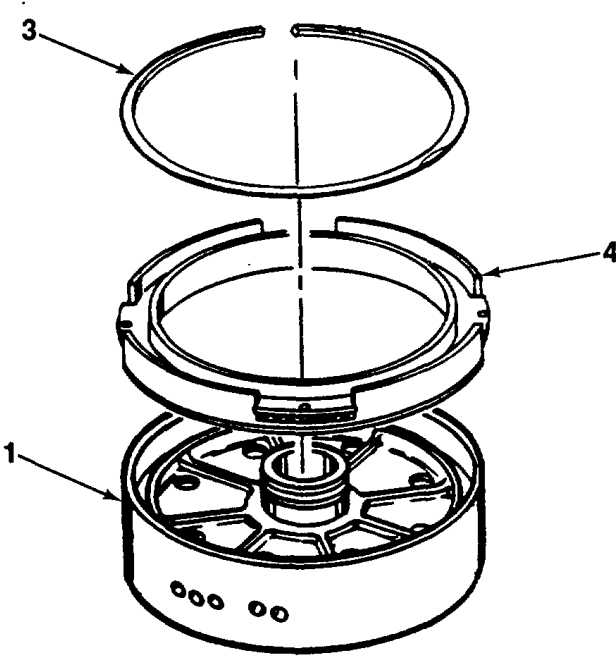

6-41. CENTER SUPPORT REPAIR (Con't).

14. Apply thin coat of grease to two new seal rings (2) and install seal rings to hub of center support (1).

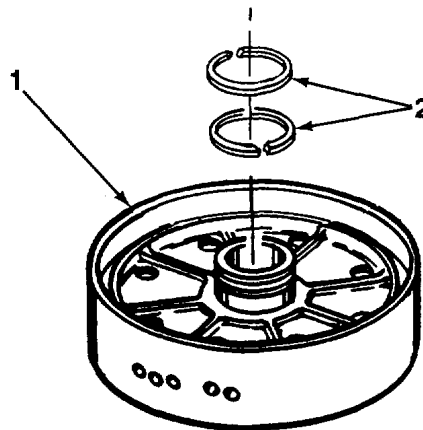
**FOLLOW-ON TASKS:**

- Install center support (see paragraph 6-24).

TA703921

CHAPTER 7
PROPELLER SHAFT AND UNIVERSAL JOINT MAINTENANCE

7-1. PROPELLER SHAFT AND UNIVERSAL JOINT REPLACEMENT.

This Task Covers:

- a. Removal
- b. Installation

Initial Setup:

Tools/Test Equipment:

- General mechanic's tool kit
- Field automotive shop set

Materials/Parts:

- Grease (Item 10, Appendix B)
- Repair kit

a. REMOVAL

NOTE

• Truck has three propeller shafts with universal joint at each end. All propeller shafts and universal joints are removed in same way. Transmission to auxiliary transmission propeller shaft shown.

• Perform following steps at each universal joint.

1. Bend tabs of four lockplates (2) flat and remove eight bolts (1) and four lockplates.

NOTE

Note position of slip joint and propeller shaft for assembly.

2. Remove four journal bearings (3) from flange (4) and slip yoke (5). Discard journal bearings.

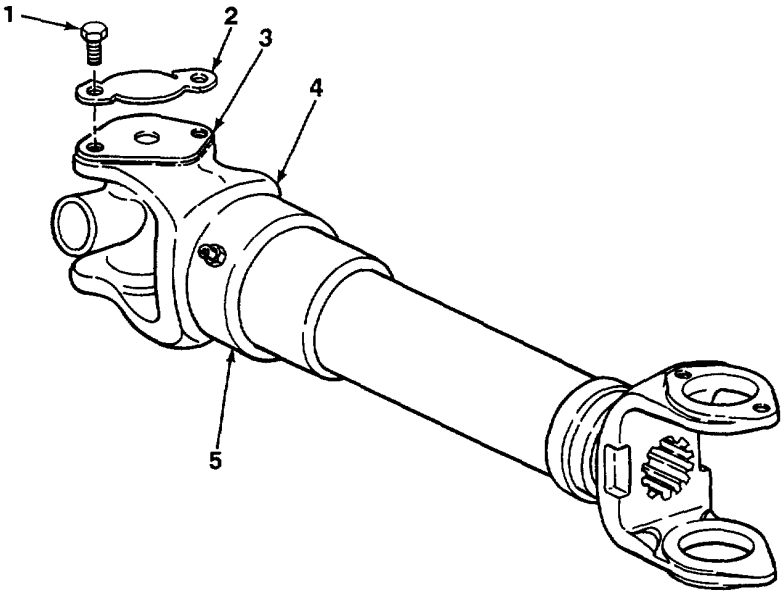

TA703922

7-1. PROPELLER SHAFT AND UNIVERSAL JOINT REPLACEMENT (Con't).

3. Remove lubricator (9) from tee (8).
4. Remove and discard four trunnion seals (6), seal retainers (7), and tee (8).

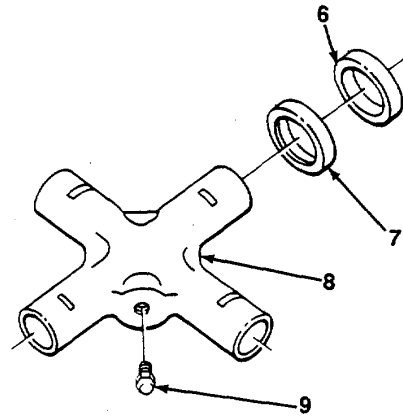

5. Remove nut (13), washer (12), and flange (4) from shaft (10).

6. Remove slinger (11) from flange (4).

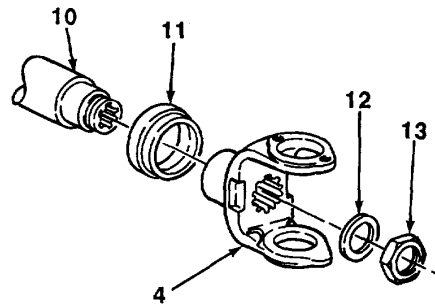

7. Remove lubrication fitting (14) from slip yoke (5).

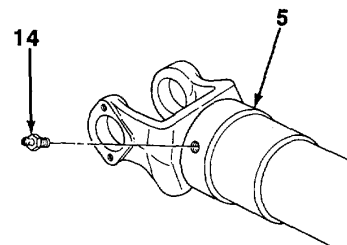

TA703923

7-1. PROPELLER SHAFT AND UNIVERSAL JOINT REPLACEMENT (Con't).

b. INSTALLATION**NOTE**

- All propeller shafts and universal joints are installed in same way.
- Perform following steps at each universal joint.

1. Install lubrication fitting (14) in slip yoke (5).
2. Press slinger (11) on flange (4).
3. Install flange (4), washer (12), and nut (13) on shaft (10).
4. Depending on which propeller shaft is replaced, tighten nut (13) to following torque:
 - At rear of transmission (15) to 750-1000 lb.-ft. (1017-1356 N m).
 - At each end of auxiliary transmission (16) to 500-550 lb.-ft. (678-746 N m).
 - At either differential (17) to 300-400 lb.-ft. (407-542 N m).

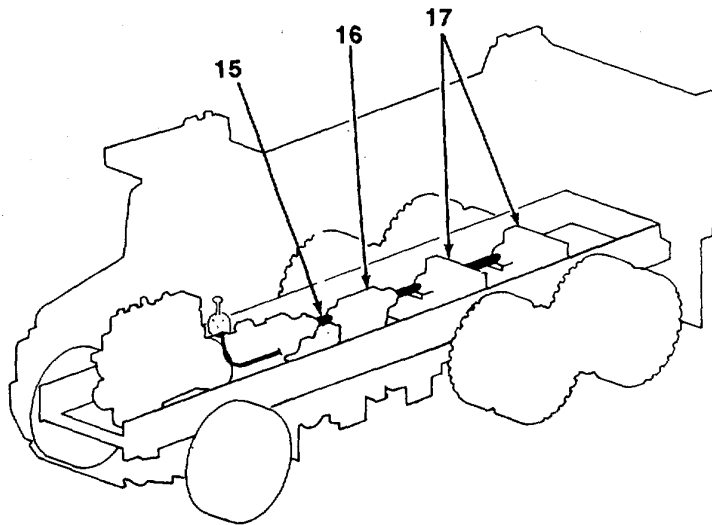

5. Install lubricator (9) to tee (8).
6. Install slip yoke or propeller shaft with new tee (8), four new seal retainers (7), and new trunnion seals (6).

TA703924

7-1. PROPELLER SHAFT AND UNIVERSAL JOINT REPLACEMENT (Con't).

7. Install four new journal bearings (3) and lockplates (2) with eight bolts (1) to flange (4) and slip yoke (5). Bend tabs of lockplates upward against side of bolts.

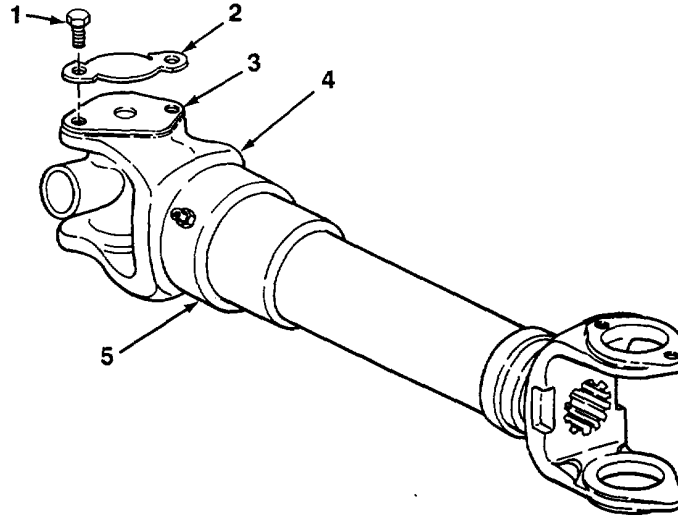
**FOLLOW-ON TASKS:**

- Lubricate universal joint(s) (see LO 5-3805-254-12).

TA703925

CHAPTER 8
AXLE MAINTENANCE

Paragraph Number	Paragraph Title	Page Number
8-1	Front Axle Replacement.....	8-1
8-2	Forward-rear and Rear-rear Axle Skid Plate Replacement.....	8-3
8-3	Forward-rear Axle Replacement	8-4
8-4	Rear-rear Axle Replacement.....	8-9

8-1. FRONT AXLE REPLACEMENT.

This Task Covers:

- a. Removal
- b. Cleaning and Inspection
- c. Installation

Initial Setup:

Equipment Conditions:

- Steering knuckles removed (see paragraph 12-8).

Tools/Test Equipment:

- General mechanic's tool kit
- Field automotive shop set

Personnel Required: Two

Materials/Parts:

- Dry cleaning solvent (Item 23, Appendix B)
- Eight locknuts

General Safety Instructions:

- Dry cleaning solvent is flammable and must not be used near open flame. Use only in a well-ventilated area.

8-1. FRONT AXLE REPLACEMENT (Con't).**a. REMOVAL****WARNING**

Front axle is heavy. Support front axle before removing locknuts. If axle falls it can cause serious injury to personnel.

1. Remove eight locknuts (4) from front axle (3). Discard locknuts.

NOTE

Wedge plates are tapered for proper caster angle. Note position of wedge plates when removing to assist in installation.

2. Lower front axle (3), two spacers (6), and wedge plates (7) from two front springs (1), and remove spacers and wedge plates from dowel pins (5).
3. Remove four U-bolts (2) and two U-bolt seats (8) from top of two front springs (1).

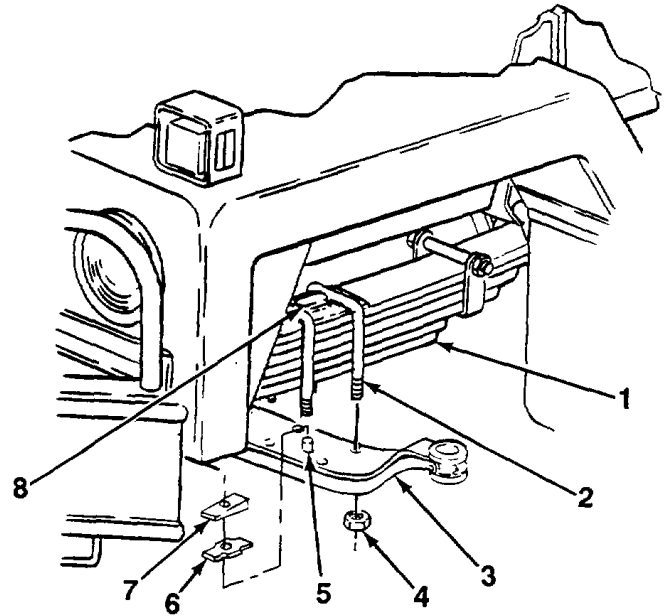
**b. CLEANING AND INSPECTION****WARNING**

Dry cleaning solvent, P-D-680, is toxic and flammable. Always wear protective goggles and gloves, and use only in a well-ventilated area. Avoid contact with skin, eyes, and clothes, and DO NOT breathe vapors. DO NOT use near open flame or excessive heat. The solvent's flash point is 100°F-1380F (380C-590C). If you become dizzy while using cleaning solvent, immediately get fresh air and medical help. If solvent contacts eyes, immediately wash your eyes and get medical aid.

1. Clean metal parts with dry cleaning solvent.
2. Inspect metal parts for cracks, breaks, and other damage. Replace if damaged.
3. Inspect two dowel pins for damage. Replace if damaged.

c. INSTALLATION

1. Position two U-bolt seats (8) and four U-bolts (2) to top of two front springs (1).
2. Install two spacers (6) and wedge plates (7) on dowel pins (5).
3. Position front axle (3) on two front springs (1) and four U-bolts (2).
4. Install front axle (3) with eight new locknuts (4). Torque locknuts to 325-400 lb.-ft. (441-542 N m).

FOLLOW-ON TASKS:

- Install steering knuckles (see paragraph 12-8).

TA703926

8-2. FORWARD-REAR AND REAR-REAR AXLE SKID PLATE REPLACEMENT.*This Task Covers:*

a. Removal

b. Installation

*Initial Setup:***Materials/Parts:**

- Four lockwashers

Tools/Test Equipment:

- General mechanic's tool kit

a. REMOVAL

NOTE**Forward-rear and rear-rear axle skid plates are removed in same manner.**

1. Remove two screws (4) from channel (5).
2. Remove two bolts (6), nuts (10), and channel (5).
3. Remove four screws (8), lockwashers (9), and skid plate (7) from housing (11). Discard lockwashers.

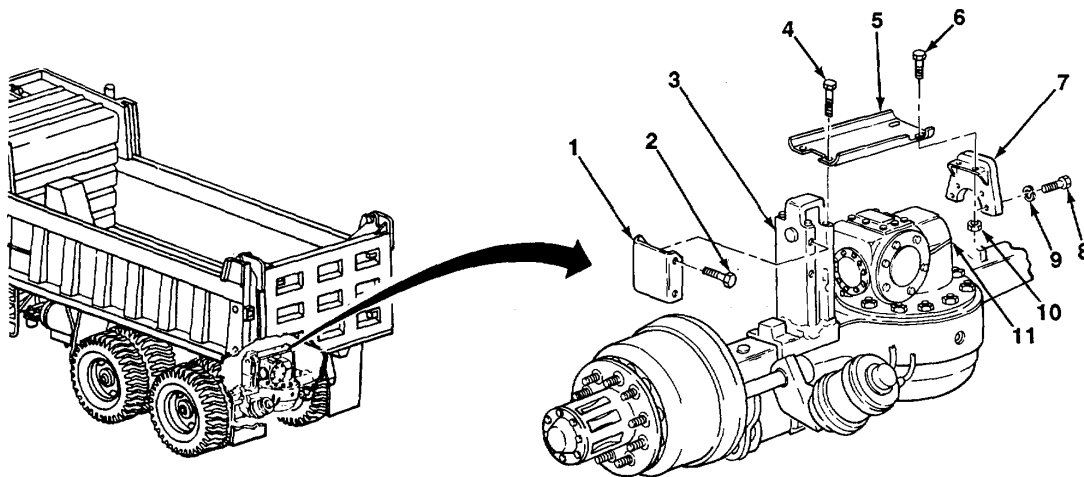

b. INSTALLATION

NOTE**Forward-rear and rear-rear axle skid plates are installed in same manner.**

1. Install skid plate (1) to axle (3) with four screws (2).
2. Install skid plate (7) to housing (11) with four new lockwashers (9) and screws (8).
3. Install channel (5) with two bolts (6) and nuts (10).
4. Install two screws (4) to channel (5).

TA703927

8-3. FORWARD-REAR AXLE REPLACEMENT.

This Task Covers:

a. Removal

b. Installation

Initial Setup:

Equipment Conditions:

- Chassis 900 elbow to rear quick-release valve hose disconnected (see TM 5-3805-254-20).
- Rear relay valve to rear quick-release valve hose disconnected (see TM 5-3805-254-20).
- Chassis T-fitting to front-rear quick-release valve hose disconnected (see TM 5-3805-254-20).
- Front relay valve to front-rear T-fitting hose disconnected (see TM 5-3805-254-20).
- Auxiliary transmission to interaxle differential propeller shaft disconnected (see paragraph 7-1).
- Forward rear-axle skid plate removed (see paragraph 8-2).
- Torque rods removed (see paragraph 13-4).

Materials/Parts:

- Two gaskets
- Sixteen lockwashers

Tools/Test Equipment:

- General mechanics tool kit
- Field automotive shop set

Personnel Required: Two

References:

- TM 5-3805-254-20
-

a. REMOVAL

1. Disconnect hose (2) from power divider air shift chamber (1).

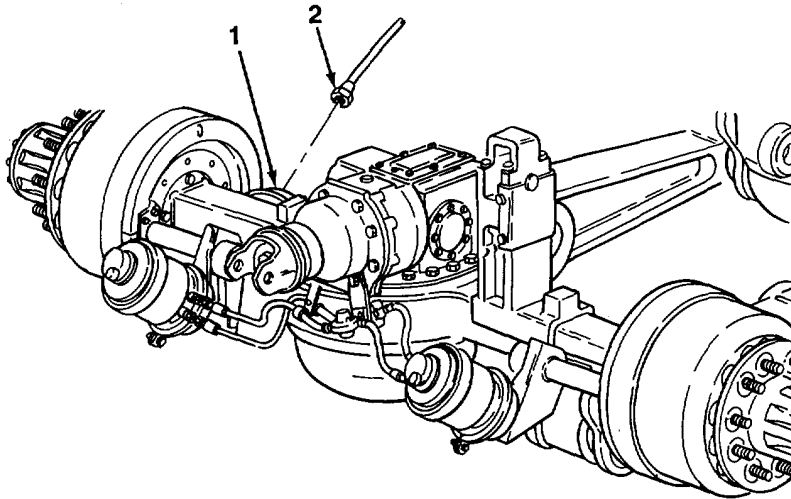

TA703928

8-3. FORWARD-REAR AXLE REPLACEMENT (Con't).

2. Remove nut (3) and bolt (4) from each of four brackets (6).
3. Remove six nuts (5) and bolts (7) from each of four brackets (6).

WARNING

Keep clear of vehicle as vehicle is lifted. Lift carefully to avoid injury or damage. Failure to follow this warning may result in serious Injury or death to personnel.

4. With overhead lifting device attached to rear of vehicle, lift rear of vehicle approximately 2 ft (0.6 m).
5. Roll tandem (8) assembly out from under vehicle.
6. Place suitable jackstands or blocking under frame at rear of vehicle and lower vehicle. Remove overhead lifting device.
7. Remove airbrake hoses and brackets from forward-rear axle (see TM 5-3805-254-20).
8. Disconnect two equalizer beams from forward-rear axle (see paragraph 13-1).

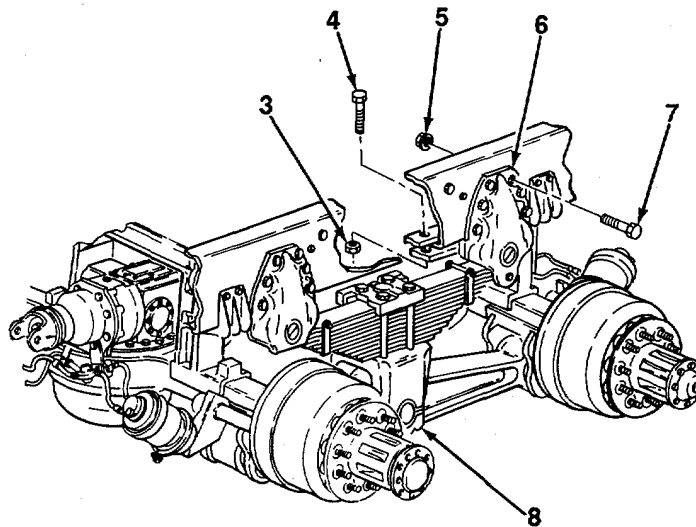

TA703929

8-3. FORWARD-REAR AXLE REPLACEMENT (Con't).

NOTE

Perform steps 9 and 10 to remove axle shaft from left and right side of forward-rear axle.

9. Remove eight nuts (11) and lockwashers (10) from end of axle shaft (12). Discard lockwashers.
10. Remove axle shaft (12) and gasket (13) from forward-rear axle (9). Discard gasket.

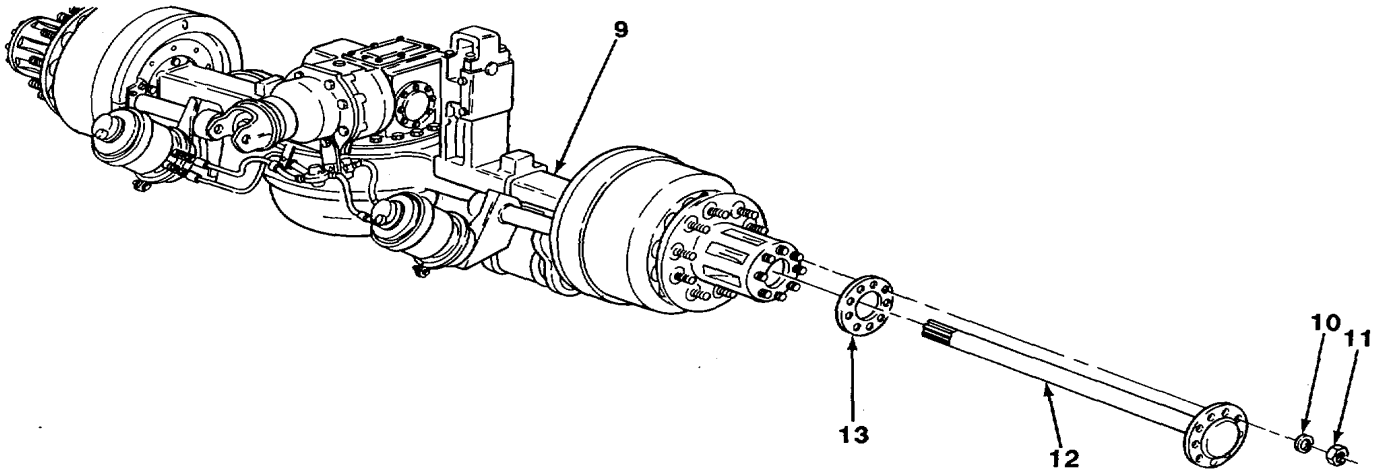

b. INSTALLATION

NOTE

Perform steps 1 and 2 to install axle shaft to left and right side of forward-rear axle.

1. Install new gasket (13) and axle shaft (12) to forward-rear axle (9).
2. Install eight new lockwashers (10) and nuts (11) to end of axle shaft (12).
3. Connect two equalizer beams to forward-rear axle (see paragraph 13-1).
4. Install airbrake hoses and brackets to forward-rear axle (see TM 5-3805-254-20).

WARNING

Keep clear of vehicle as vehicle is lifted. Lift carefully to avoid Injury or damage. Failure to follow this warning may result in injury or death to personnel.

5. With overhead lifting device attached to rear of vehicle, lift rear of vehicle approximately 2 ft (0.6 m).
6. Remove jackstands or blocking from under frame.

TA703930

8-3. FORWARD-REAR AXLE REPLACEMENT (Con't).

- 7. Roll tandem (8) assembly under rear of vehicle.
- 8. Lower vehicle and align tandem (8) assembly to frame.
- 9. Install six bolts (7) and nuts (5) in each of four brackets (6).
- 10. Install bolt (4) and nut (3) in each of four brackets (6).

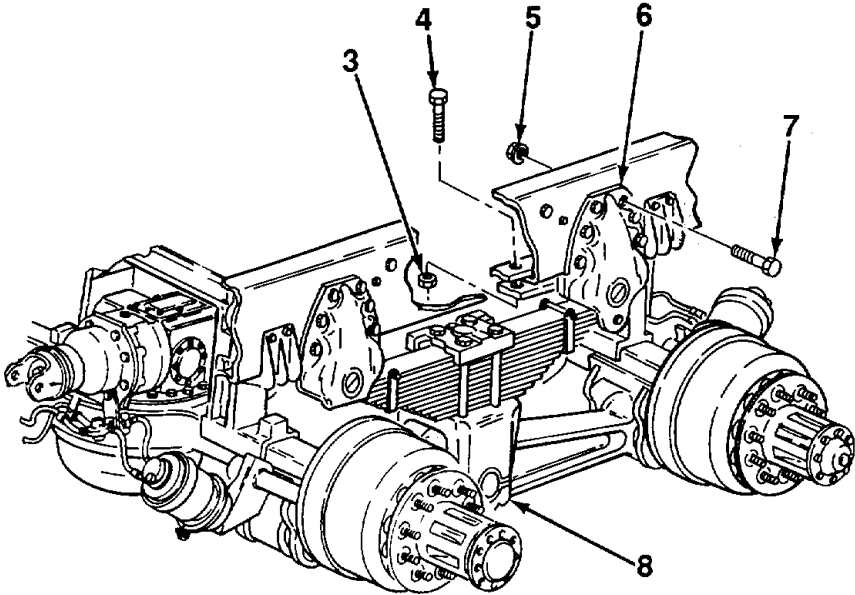

- 11. Connect hose (2) to power divider air shift chamber (1).

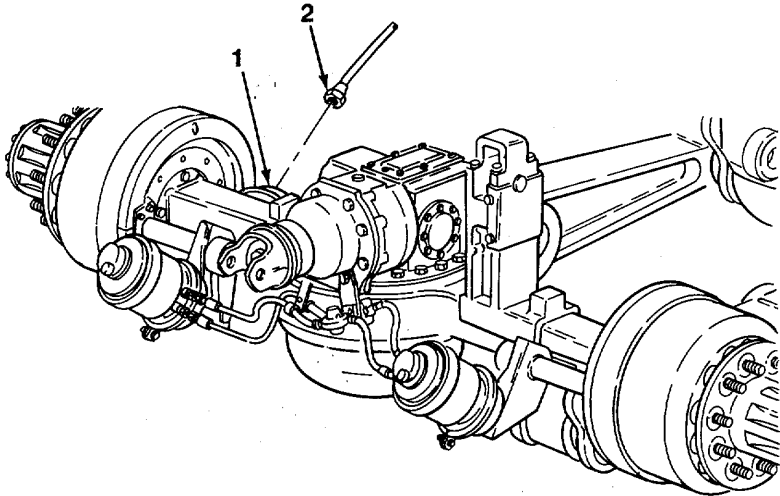

8-3. FORWARD-REAR AXLE REPLACEMENT (Con't).

FOLLOW-ON TASKS:

- Install torque rod (see paragraph 13-4).
- Install forward-rear axle skid plate (see paragraph 8-2).
- Connect auxiliary transmission to interaxle differential propeller shaft (see paragraph 7-1).
- Connect front relay valve to front-rear T-fitting hose (see TM 5-3805-254-20).
- Connect chassis T-fitting to front-rear quick-release valve hose (see TM 5-3805-254-20).
- Connect rear relay valve to rear quick-release valve hose (see TM 5-3805-254-20).
- Connect chassis 900 elbow to rear quick-release valve hose (see TM 5-3805-254-20).

8-4. REAR-REAR AXLE REPLACEMENT.*This Task Covers:*

- a. Removal
- b. Installation

*Initial Setup:***Equipment Conditions:**

- Chassis 900 elbow to rear quick-release valve hose disconnected (see TM 5-3805-254-20).
- Rear relay valve to rear quick-release valve hose disconnected (see TM 5-3805-254-20).
- Auxiliary transmission to interaxle differential propeller shaft disconnected (see paragraph 7-1).
- Rear-rear axle skid plate removed (see paragraph 8-2).
- Torque rods removed (see paragraph 13-4).

Materials/Parts:

- Two gaskets
- Sixteen lockwashers

Tools/Test Equipment:

- General mechanic's tool kit
- Field automotive shop set

Personnel Required: Two**References:**

- TM 5-3805-254-20

a. REMOVAL

1. Disconnect hose (2) from power divider air shift chamber (1).

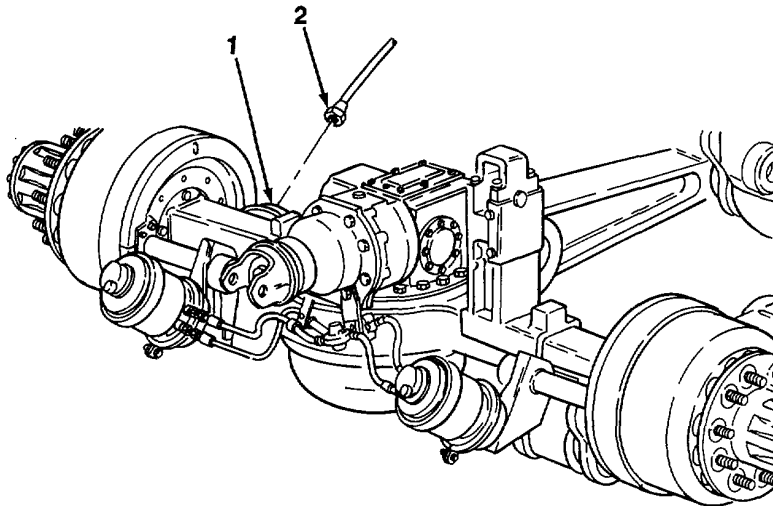

TA703932

8-4. REAR-REAR AXLE REPLACEMENT (Con't).

2. Remove nut (3) and bolt (4) from each of four brackets (6).
3. Remove six nuts (5) and bolts (7) from each of four brackets (6).

WARNING

Keep clear of vehicle as vehicle is lifted. Lift carefully to avoid Injury or damage. Failure to follow this warning may result in injury or death to personnel.

4. With overhead lifting device attached to rear of vehicle, lift rear of vehicle approximately 2 ft (0.6 m).
5. Roll tandem (8) assembly out from under vehicle.

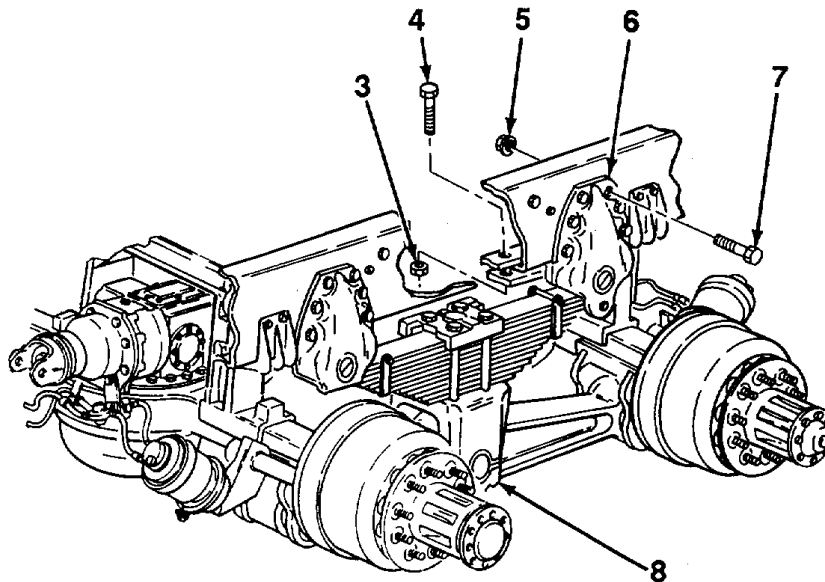

6. Place suitable jackstands or blocking under frame at rear of vehicle and lower vehicle. Remove overhead lifting device.
7. Remove airbrake hoses and brackets from rear-rear axle (13) (see TM 5-3805-254-20).

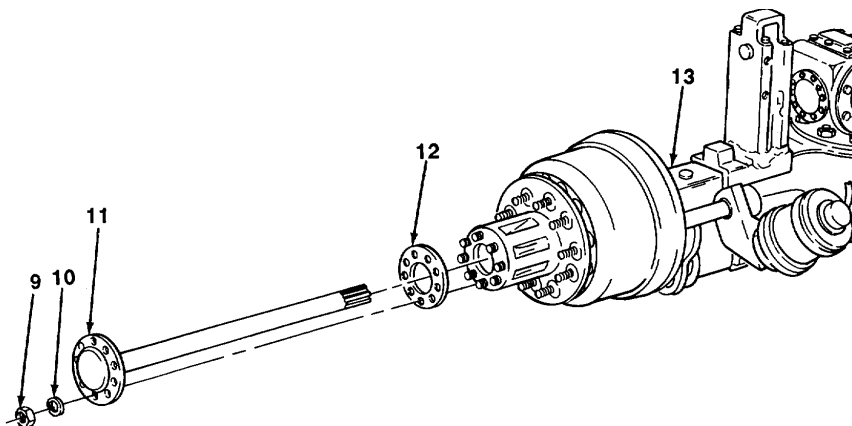

TA703933

8-4. REAR-REAR AXLE REPLACEMENT (Con't).

8. Disconnect forward-rear differential to rear-rear differential propeller shaft (see paragraph 7-1).
9. Disconnect equalizer beams from rear-rear axle (see paragraph 13-1).

NOTE

Perform steps 10 and 11 to remove axle shaft from left and right side of rear-rear axle.

10. Remove eight nuts (9) and lockwashers (10) from end of axle shaft (11). Discard lockwashers.
11. Remove axle shaft (11) and gasket (12) from rear-rear axle (13). Discard gasket.

b. INSTALLATION**NOTE**

Perform steps 1 and 2 to install axle shaft to left and right side of rear-rear axle.

1. Install new gasket (12) and axle shaft (11) to rear-rear axle (13).
2. Install eight new lockwashers (10) and nuts (9) to end of axle shaft (11).
3. Connect equalizer beams to rear-rear axle (see paragraph 13-1).
4. Connect forward-rear differential to rear-rear differential propeller shaft (see paragraph 7-1).
5. Install airbrake hoses and brackets to rear-rear axle (13) (see TM 5-3805-254-20).

WARNING

Keep clear of vehicle as vehicle is lifted. Lift carefully to avoid injury or damage. Failure to follow this warning may result in injury or death to personnel.

6. With overhead lifting device attached to rear of vehicle, lift rear of vehicle approximately 2 ft (0.6 m).
7. Remove jackstands or blocking from under frame.
8. Roll tandem (8) assembly under rear of vehicle.
9. Lower vehicle and align tandem (8) assembly to frame.
10. Install six bolts (7) and nuts (5) in each of four brackets (6).
11. Install bolt (4) and nut (3) to each of four brackets (6).

8-4. REAR-REAR AXLE REPLACEMENT (Con't).

12. Connect hose (2) to power divider air shift chamber (1).

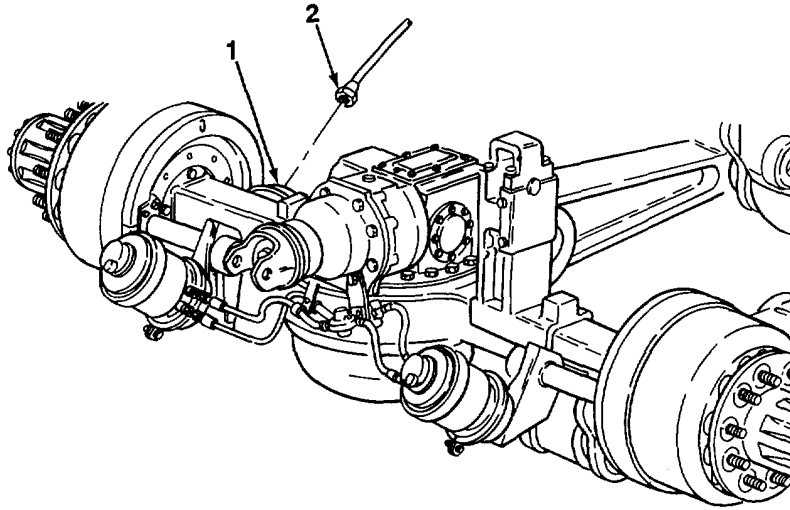
**FOLLOW-ON TASKS:**

- Install torque rods (see paragraph 13-4).
- Install rear-rear axle skid plate (see paragraph 8-2).
- Connect auxiliary transmission to interaxle differential propeller shaft (see paragraph 7-1).
- Connect rear relay valve to rear quick-release valve hose (see TM 5-3805-254-20).
- Connect chassis 900 elbow to rear quick-release valve hose (see TM 5-3805-254-20).

TA703934

**CHAPTER 9
DIFFERENTIAL MAINTENANCE**

Paragraph Number	Paragraph Title	Page Number
9-1	Forward-rear Differential Maintenance.....	9-1
9-2	Interaxle Differential Maintenance.....	9-20
9-3	Power Divider Differential Air Shift Chamber Maintenance.....	9-33
9-4	Rear Axle Power Differential Lock Replacement	9-37
9-5	Rear-rear Differential Maintenance	9-39

9-1. FORWARD-REAR DIFFERENTIAL MAINTENANCE.

This Task Covers:

- | | |
|---|--|
| <ul style="list-style-type: none"> a. Differential Carrier Removal b. Differential Removal and Disassembly c. Thru Shaft Removal and Disassembly d. Cross-shaft Removal and Disassembly e. Cleaning and Inspection | <ul style="list-style-type: none"> f. Cross-shaft Assembly and Installation g. Thru Shaft Assembly and Installation h. Differential Assembly and Installation i. Differential Carrier Installation |
|---|--|

Initial Setup:

Equipment Conditions:

- Forward-rear axle removed (see paragraph 8-3)
- Forward-rear axle shafts removed (see paragraph 8-3)
- Interaxle differential removed (see paragraph 9-2)
- Forward-rear differential drained (see TM 5-3805-254-20)

Tools/Test Equipment

- General mechanic's tool kit
- Field automotive shop set
- Two cross-shaft removal spacers

General Safety Instructions:

- Dry cleaning solvent is flammable and must not be used near open flame. Use only in a well-ventilated area

Materials/Parts:

- Abrasive cloth (Item 4, Appendix B)
- Grease (Item 10, Appendix B)
- Lubricating oil (Item 13, Appendix B)
- Rags (Item 17, Appendix B)
- Sealing compound (Item 19, Appendix B)
- Dry cleaning solvent (Item 23, Appendix B)
- Marker tags (Item 25, Appendix B)
- Twine (Item 32, Appendix B)
- Nonelectrical wire (Item 34, Appendix B)
- Five gaskets
- Forty-four lockwashers

Personnel Required: Two

References:

- TM 9-214

9-1. FORWARD-REAR DIFFERENTIAL MAINTENANCE (Con't).

a. DIFFERENTIAL CARRIER REMOVAL

1. Match-mark differential carrier (2) and forward-rear axle housing (5) for assembly.
2. Remove 18 nuts (1) and lockwashers (6) from studs (4) of forward-rear axle housing (5). Discard lockwashers.

NOTE

Removal of assembled differential carrier may require tapping with mallet to loosen gasket material.

3. Remove differential carrier (2) and gasket (3) from forward-rear axle housing (5). Discard gasket.
4. If damaged, remove 18 studs (4) from forward-rear axle housing A(5).

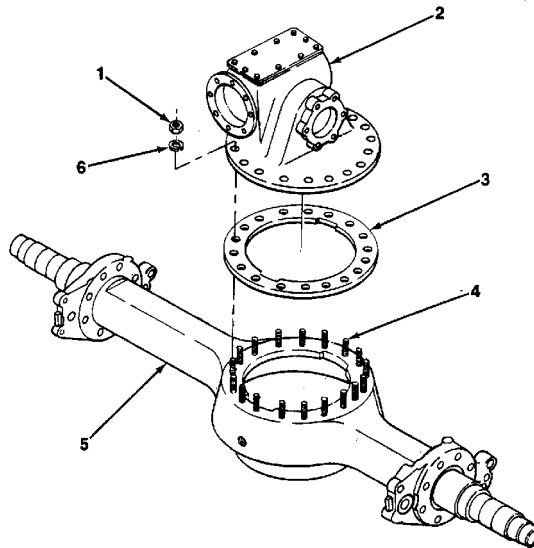

TA703935

9-1. FORWARD-REAR DIFFERENTIAL MAINTENANCE (Con't).

b. DIFFERENTIAL REMOVAL AND DISASSEMBLY I

- 1. Mount differential carrier (2) in vise with soft jaws.
- 2. Cut lockwire (7) securing bolts (8) in bearing cap (9). Discard lockwire.
- 3. Mark bearing cap (9) and legs of differential carrier (2) to ensure proper assembly and installation.
- 4. Remove two bolts (8) and bearing cap (9).
- 5. Repeat steps 2 through 4 for other bearing cap (9).
- 6. Lift differential (11) out of differential carrier (2).
- 7. Remove two bearing races (10) from legs of differential carrier (2).

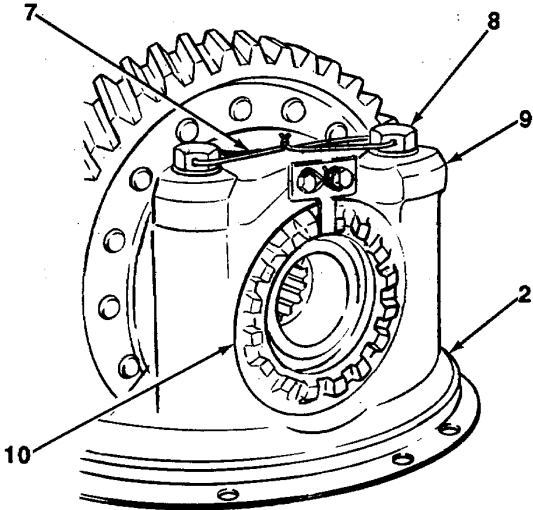

WARNING

Tightly hold no-spin differential together to contain spring pressure as differential case half is removed. Failure to follow this warning may result in Injury to personnel or damage to differential case assembly components.

NOTE

Bolt, two washers, and nut used in step 8 should be from shop stock and are used to hold no-spin differential assembly together when differential case half is removed.

- 8. Install bolt (12), two washers (13), and nut (15) through center of no-spin differential assembly (14). Tighten nut fingertight.

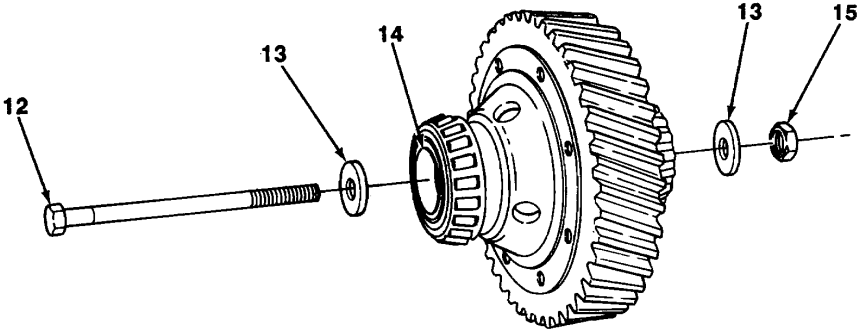

TA703936

9-1. FORWARD-REAR DIFFERENTIAL MAINTENANCE (Con't).

9. Scribe a line on each half of differential case (18) and driven gear (19) to ensure that assembly is in the same position.
10. Cut lockwire and remove 12 bolts (20) and nuts (21) from differential case (18). Discard lockwire.
11. Remove one-half of differential case (18).

NOTE

No-spin differential is available as an assembly only. There are no repair parts available. If a part of differential is damaged, replace complete no-spin differential assembly.

12. Remove no-spin differential assembly (14) from differential case (18) half.
13. If damaged, remove two bearings (17) and spacers (16) from ends of differential case (18).

NOTE

Perform steps 14 through 17 only if disassembly of no-spin differential assembly is required for inspection purposes.

14. Install no-spin differential assembly (14) in arbor press.

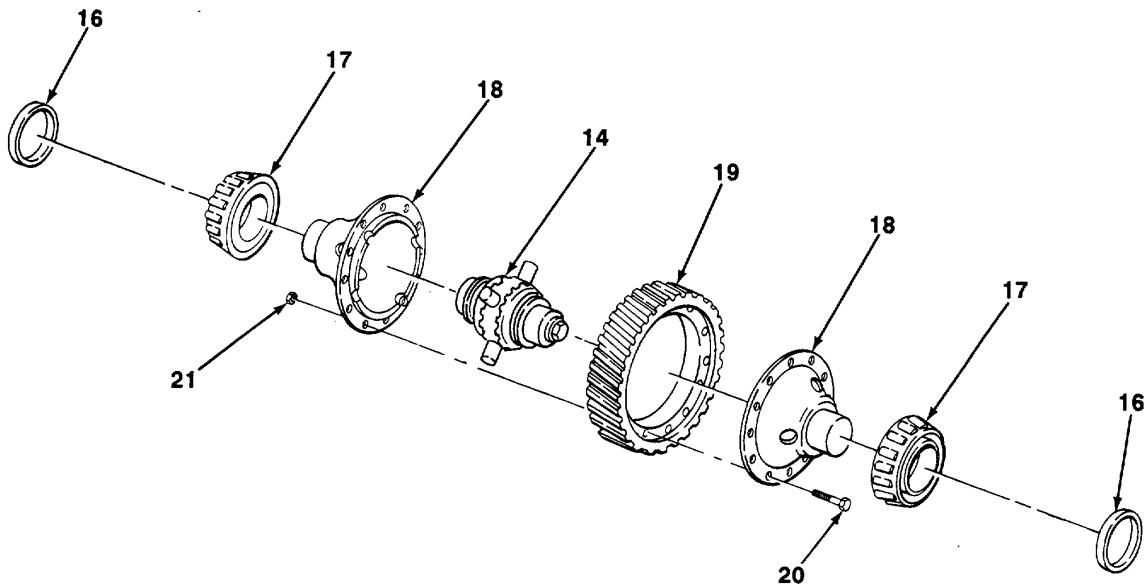

TA703937

9-1. FORWARD-REAR DIFFERENTIAL MAINTENANCE (Con't).

15. Press on head of bolt (12) to release spring pressure against nut (15), and remove nut and washer (13).
16. Slowly release pressure and allow no-spin differential assembly (14) to separate until spring pressure is fully released.
17. Remove two side gears (22), springs (23), spring retainers (24), and drive gears (25) from spider (26).

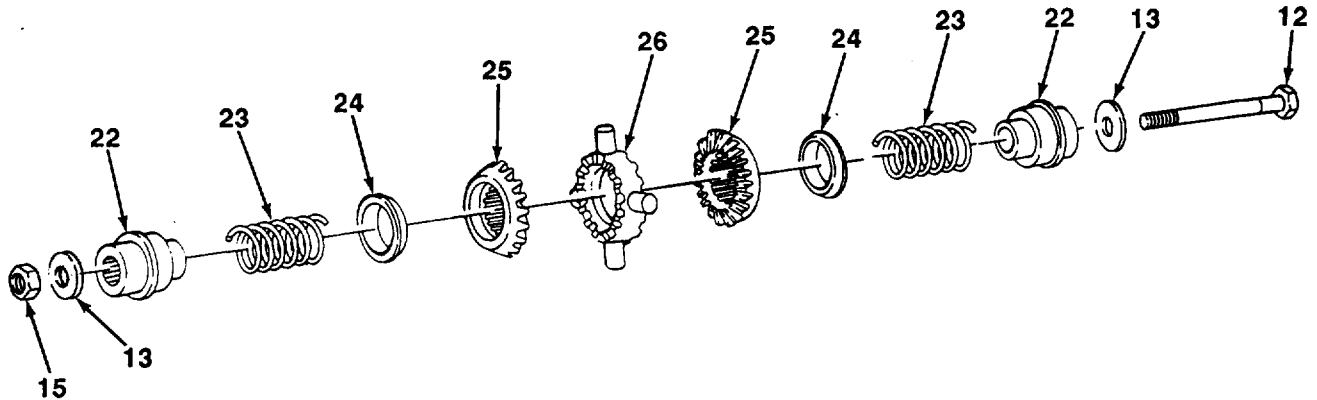

c. THRU SHAFT REMOVAL AND DISASSEMBLY

1. Remove eight bolts (36) and lockwashers (35) from bearing retainer (28). Discard lockwashers.
2. Drive thru shaft (30) out of differential carrier (2) using mallet.
3. Remove bearing retainer (28) and gasket (29) from thru shaft (30). Discard gasket.
4. If damaged, remove seal (27) from bearing retainer (28). Discard seal.

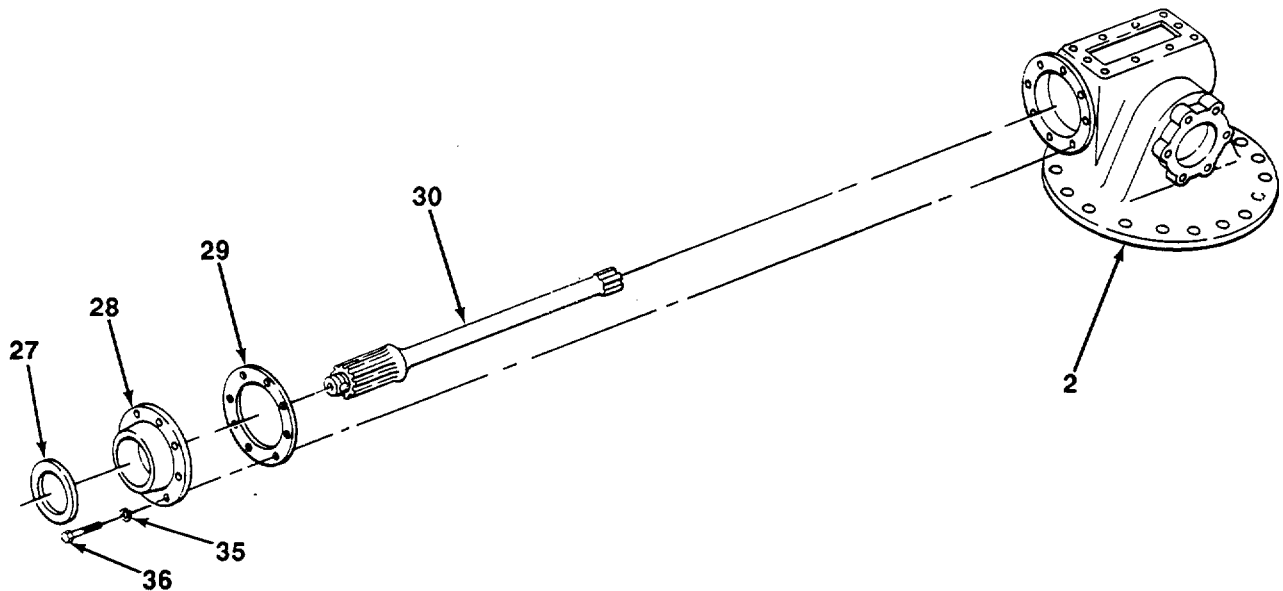

TA703938

9-1. FORWARD-REAR DIFFERENTIAL MAINTENANCE (Con't).

5. Remove cage (32) and gasket (33) from thru shaft (30). Discard gasket.
6. Remove spacer (34) from thru shaft (30).
7. If damaged, remove thru shaft bearing (31).

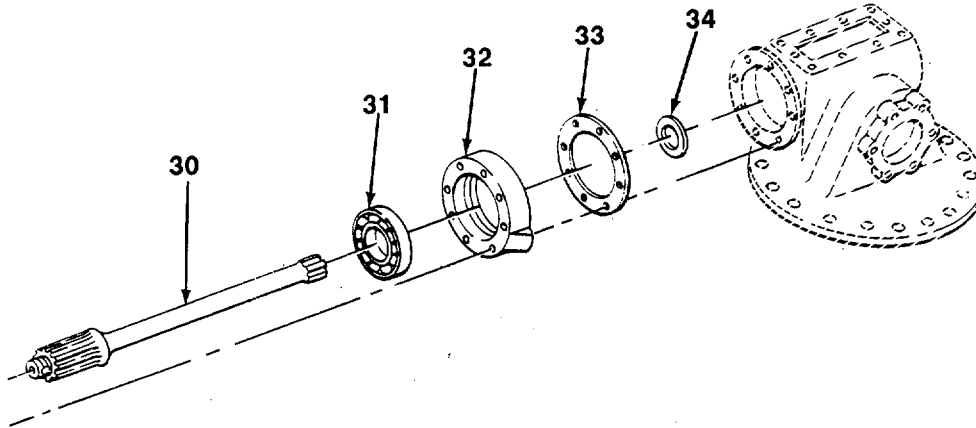
d. CROSS-SHAFT REMOVAL AND DISASSEMBLY I

1. Remove ten screws (38), lockwashers (37), cover (39), and gasket (40) from differential carrier (2). Discard gasket and lockwashers.
2. Cut lockwire from bolt heads and remove six bolts (43), bearing retainer plate (42), and shims (41) from differential carrier (2). Attach shims to bearing retainer plate for installation. Discard lockwire.

TA703939

9-1. FORWARD-REAR DIFFERENTIAL MAINTENANCE (Con't).

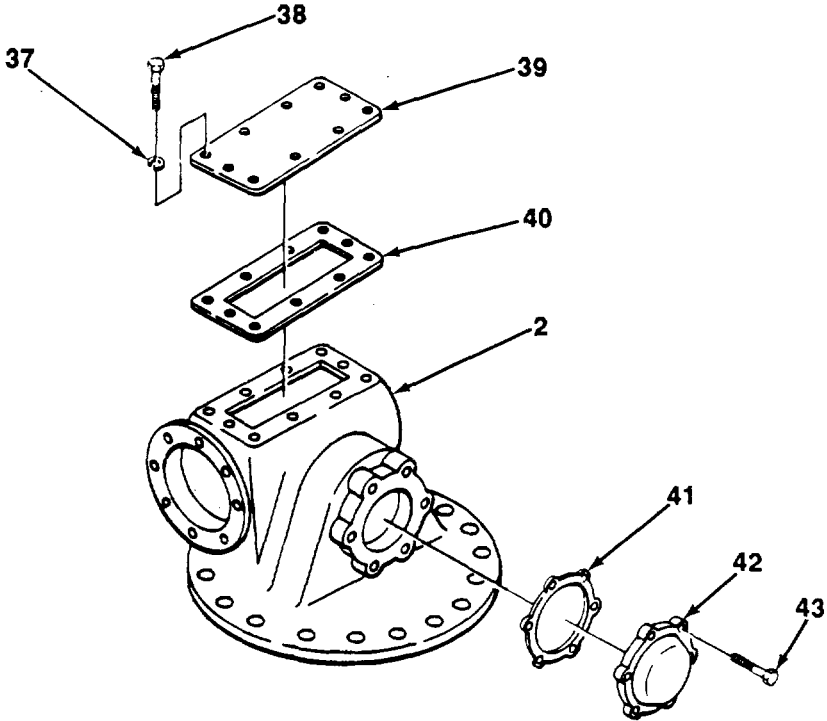

3. Remove eight bolts (47), lockwashers (46), cover (44), and gasket (45) from differential carrier (2). Discard gasket and lockwashers.

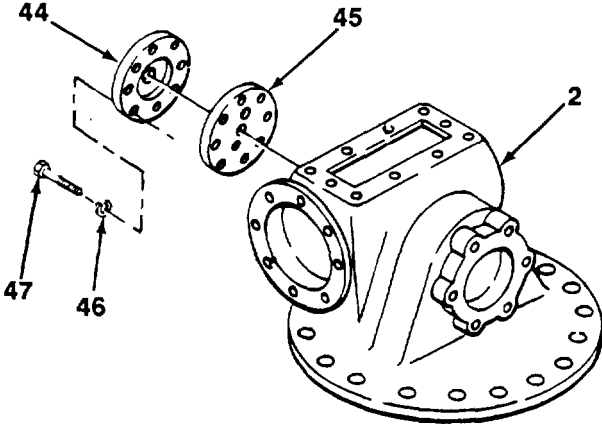

9-1. FORWARD-REAR DIFFERENTIAL MAINTENANCE (Con't).

NOTE

Bearings and bearing races will remain Inside bearing housing during step 4. These will only be removed if damaged, in subparagraph e.

- 4. Remove bearing housing (49) and shims (48) from differential carrier (2). Attach shims to bearing housing to ensure that same number are installed.

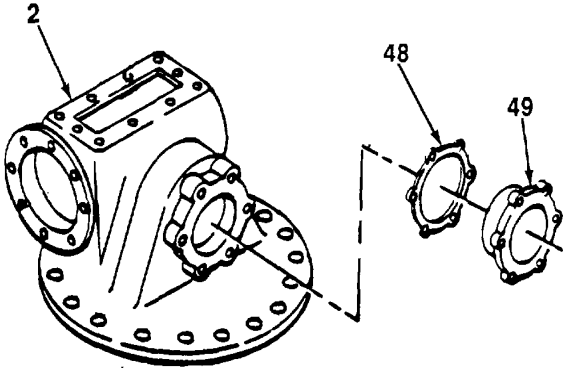

- 5. Tap cross-shaft (50) and ring gear set (51) toward thru shaft chamber of differential carrier (2).
- 6. Install two cross-shaft removal spacers (52) between back of ring gear set (51) and inner wall of differential carrier (2).
- 7. Press cross-shaft (50) from differential carrier (2). Remove two cross-shaft removal spacers (52) from differential carrier.

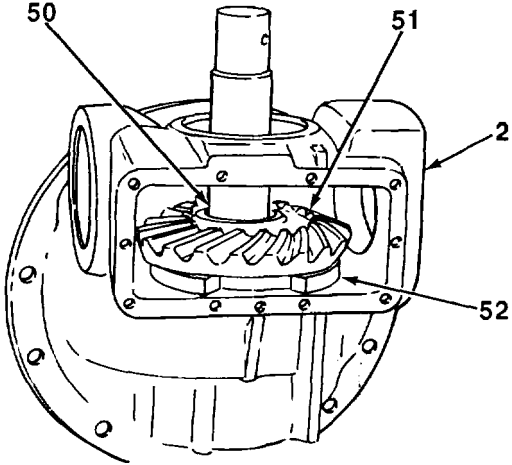

9-1. FORWARD-REAR DIFFERENTIAL MAINTENANCE (Con't).

8. Remove key (55) from cross-shaft (50).
9. Cut lockwire (57) and remove three screws (57) and adjusting washer (56) from cross-shaft (50). Discard lockwire.
10. Press out ring gear set (51) and bearing (54) as a unit, and remove from differential carrier (2). Do not lose recessed washer (53).
11. Remove recessed washer (53) if it did not come loose during removal of ring gear set (51).

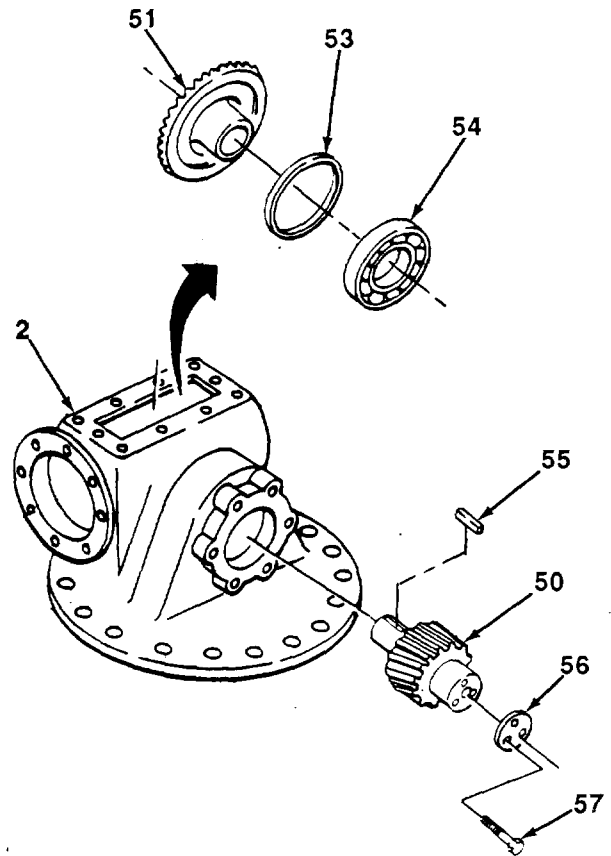
**e. CLEANING AND INSPECTION****WARNING**

Dry cleaning solvent, P-D-680, is toxic and flammable. Always wear protective goggles and gloves, and use only in a well-ventilated area. Avoid contact with skin, eyes, and clothes, and DO NOT breathe vapors. DO NOT use near open flame or excessive heat. The solvent's flash point is 100°F-138°F (38°C-59°C). If you become dizzy while using cleaning solvent, immediately get fresh air and medical help. If solvent contacts eyes, immediately wash your eyes and get medical aid.

1. Clean all metal parts with dry cleaning solvent and allow to air dry.

TA703942

9-1. FORWARD-REAR DIFFERENTIAL MAINTENANCE (Con't).

NOTE
If one differential case bearing needs to be r bearings.

- 2. Inspect bearings for damage (see TM 9-214).
- 3. Inspect gear bearing sleeve (59) inside differential carrier (2). If damaged, remove setscrew (58) and gear bearing sleeve.
- 4. Press replacement gear bearing sleeve (59) into differential carrier (2). Drill setscrew hole in gear bearing sleeve and install set screw (58).

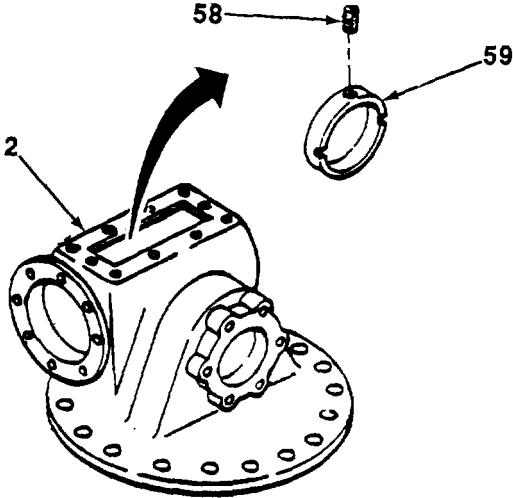

- 5. Inspect bearings (61) and bearing races (60) inside bearing housing (49) (see TM 9-214). If damaged, replace bearings and bearing races.

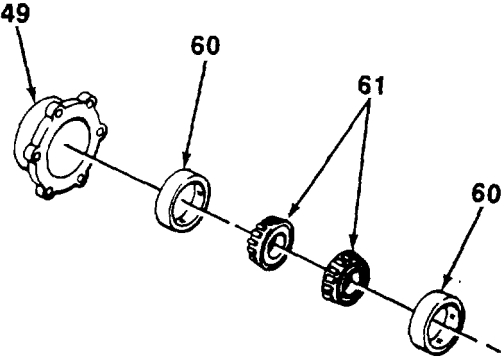

9-1. FORWARD-REAR DIFFERENTIAL MAINTENANCE (Con't).

f. CROSS-SHAFT ASSEMBLY AND INSTALLATION

1. Apply grease to center hole of ring gear set (51) and bearing (54) and install along with recessed washer (53) into differential carrier (2).

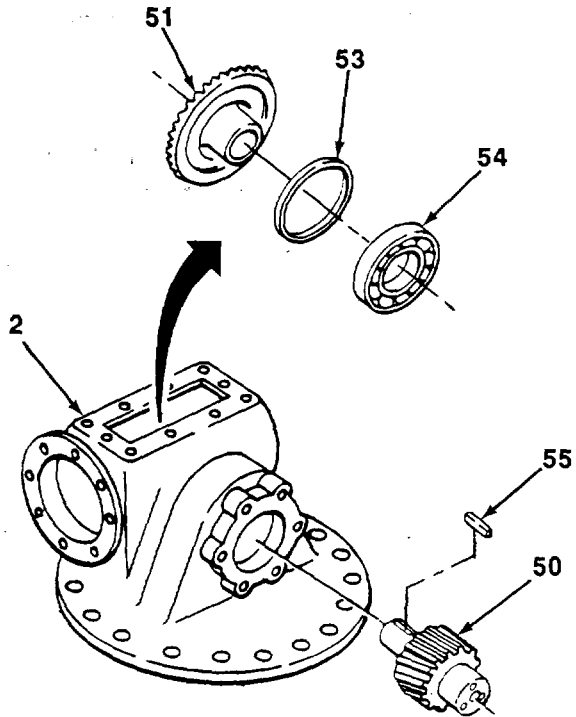

2. Use two cross-shaft removal spacers (52) to hold ring gear set (51) away from differential carrier (2) wall.

3. Apply grease to entering shaft of cross-shaft (50).

4. Press cross-shaft (50) and key (55) into ring gear set (51).

5. Remove two cross-shaft removal spacers (52) from differential carrier (2).

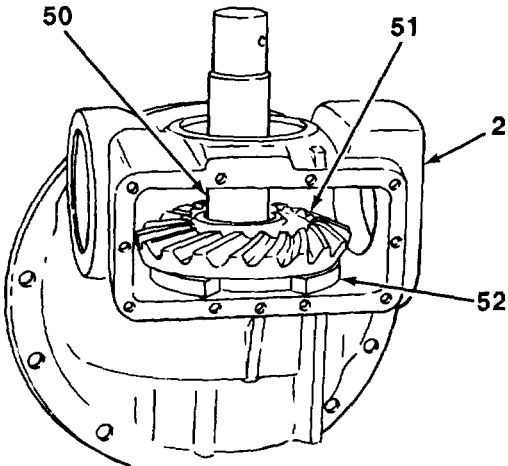

9-1. FORWARD-REAR DIFFERENTIAL MAINTENANCE (Con't).

- 6. Install new gasket (45) and cover (44) on differential carrier (2) with eight new lockwashers (46) and bolts (47).

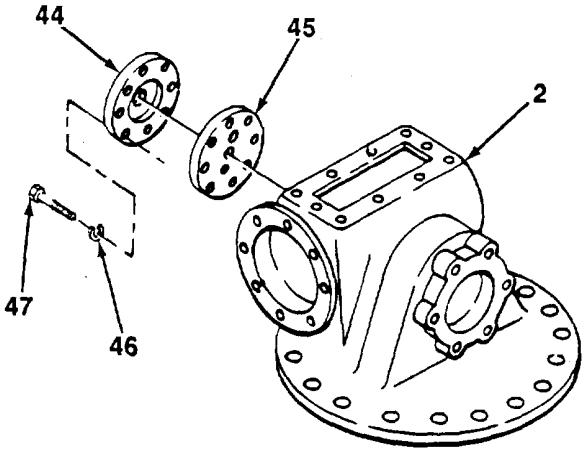

NOTE

Shims in step 7 control gear backlash.

- 7. Install original shims (48) over cross-shaft opening (62) in differential carrier (2).
- 8. Apply grease to bearing Journal (63) of cross-shaft (50).

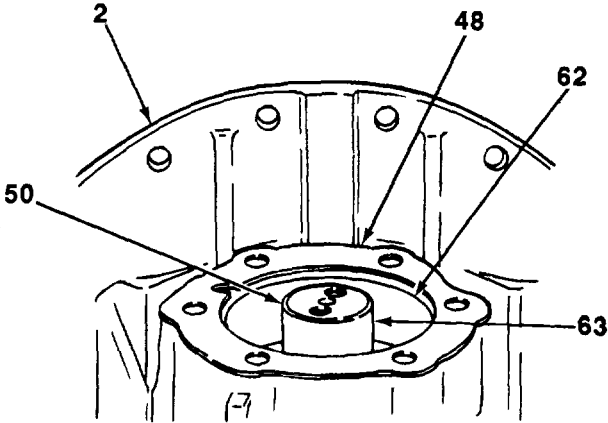

- 9. Aline bearing housing (49) in differential carrier (2), ensuring that all oil holes are alined. Prep bearing housing into differential carrier.

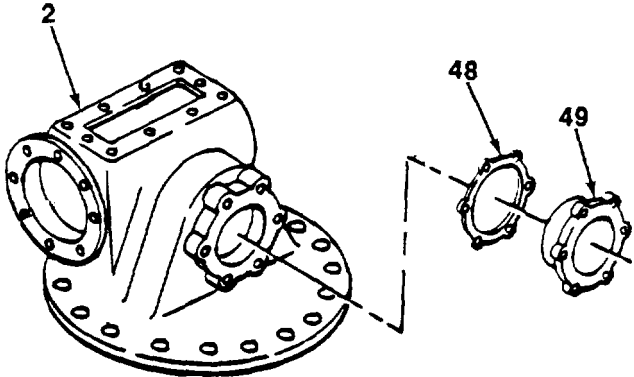

9-1. FORWARD-REAR DIFFERENTIAL MAINTENANCE (Con't).

- 10. Install adjusting washer (56) to cross-shaft (5) with three screws (57). Torque screws to 69 lb.- (94 N-m). Install new lockwire to screw heads (see paragraph 1-21).

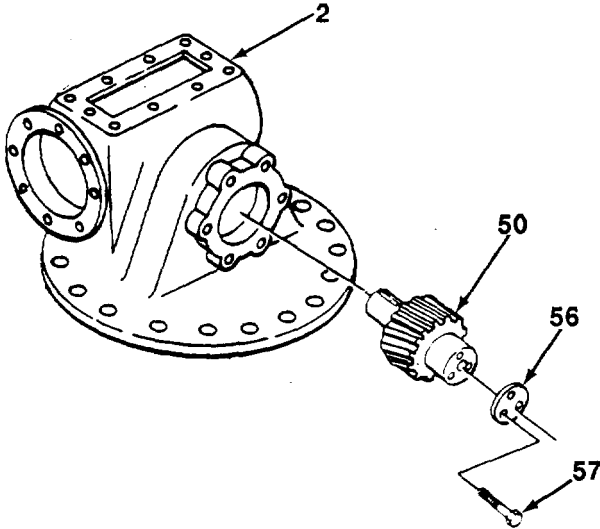

NOTE

Shims in step 11 control preload torque.

- 11. Install original shims (41).
- 12. Install bearing retainer plate (42) to differential carrier (2) with six bolts (43). Torque bolts 76 lb.-ft. (103 N-m). Install new lockwire to be heads (see paragraph 1-21).

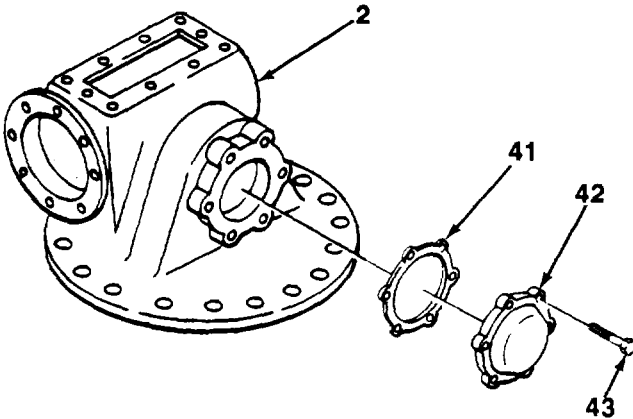

9-1. FORWARD-REAR DIFFERENTIAL MAINTENANCE (Con't).

13. Wrap strong twine around pinion (64) of cross-shaft (50) and pull on horizontal line with spring scale. Preload torque should be 5-15 lb.-in. (7-20 N•m).

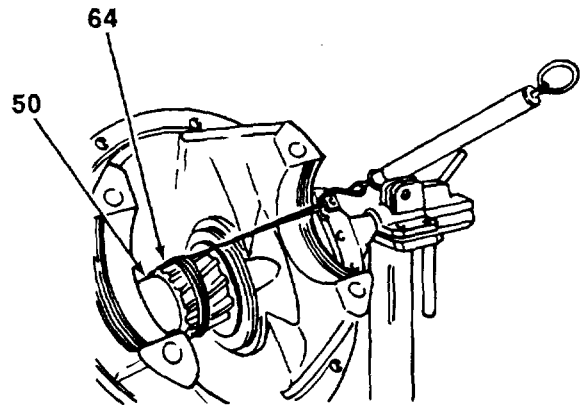

14. If preload torque is not correct, remove six bolts (43) and bearing retainer plate (42) from differential carrier (2). Add shims (41) to decrease preload torque or remove shims to increase preload torque.

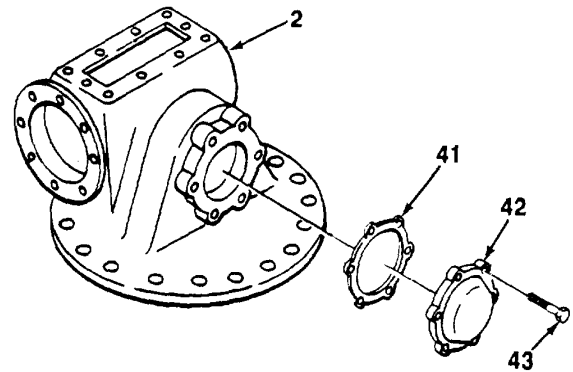

15. Mount dial indicator on side of differential carrier (2).

16. Check differential backlash. Backlash should be 0.005-0.015 in. (0.127-0.381 mm).

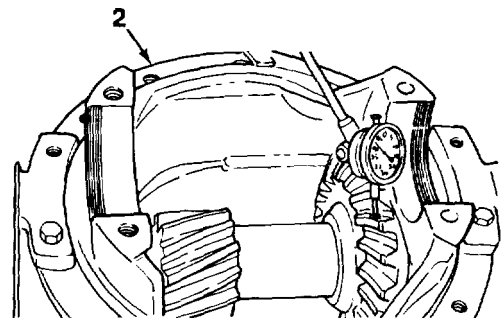

TA703947

9-1. FORWARD-REAR DIFFERENTIAL MAINTENANCE (Con't).

17. If backlash is not correct, remove bearing housing (49) from differential carrier (2) and add shims (48) to decrease backlash, or remove shims to increase backlash.

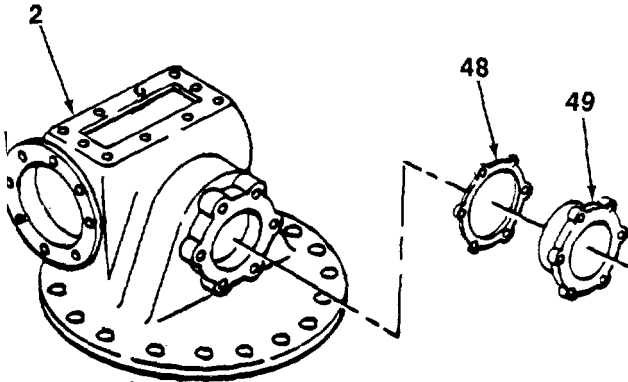

g. THRU SHAFT ASSEMBLY AND INSTALLATION

1. If removed, coat new seal (27) with sealing compound and install in bearing retainer (28). Coat sealing element with grease.
2. If removed, install thru shaft bearing (31) on thru shaft (30).
3. Install spacer (34) onto end of thru shaft (30).
4. Install cage (32) onto thru shaft bearing (31) of thru shaft (30).
5. Install new gasket (29) and bearing retainer (28) onto thru shaft bearing (31) of thru shaft (30). Ensure that holes in bearing retainer align with holes in cage (32).
6. Install new gasket (33) and thru shaft (30) into differential carrier (2) with eight new lockwashers (35) and bolts (36). Torque bolts to 46 lb.-ft. (62 N•m).

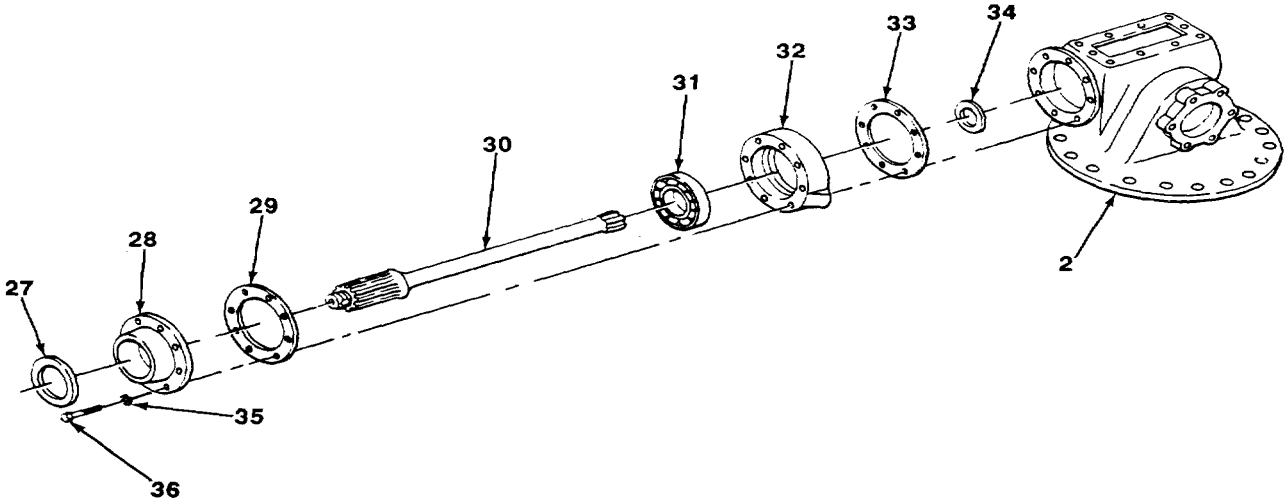

9-1. FORWARD-REAR DIFFERENTIAL MAINTENANCE (Con't).

h. DIFFERENTIAL ASSEMBLY AND INSTALLATION

NOTE

If no-spin differential was disassembled, perform steps 1 through 5. If not, go to step 6.

- 1. Install two drive gears (25), spring retainers (24), springs (23), and side gears (22) on spider (26).
- 2. Install bolt (12) and washer (13) through center of assembly.

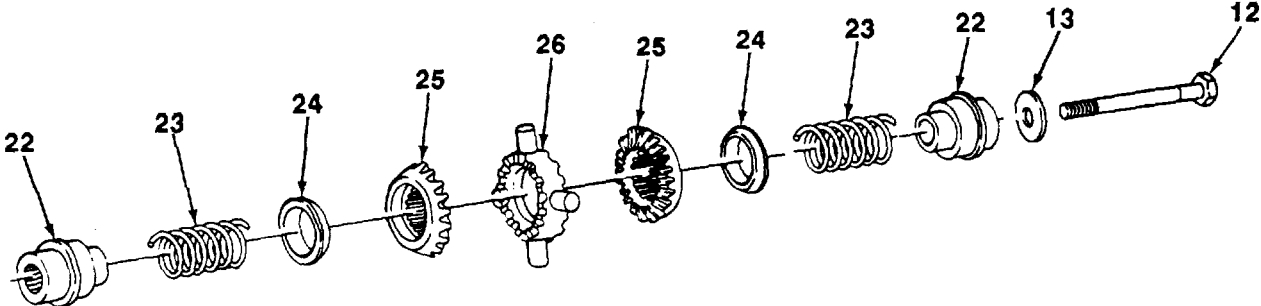

- 3. Place no-spin differential assembly (14) on arbor press.
- 4. Press on head of bolt (12) and compress no-spin differential assembly (14) slowly. As no-spin differential assembly in compressed, ensure that splines of side gears (22) and drive gears (25) mesh.

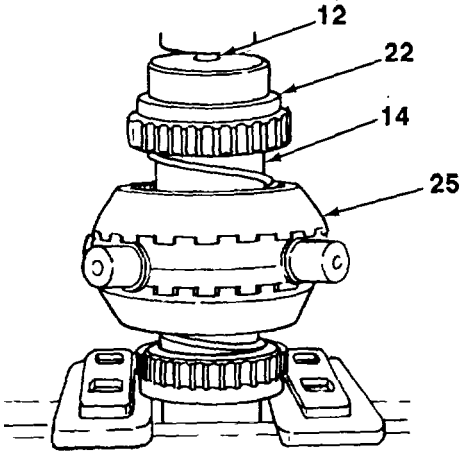

9-1. FORWARD-REAR DIFFERENTIAL MAINTENANCE (Con't).

5. Install washer (13) and nut (15) on bolt (12) to hold no-spin differential assembly (14) together. Remove no-spin differential assembly from arbor press.

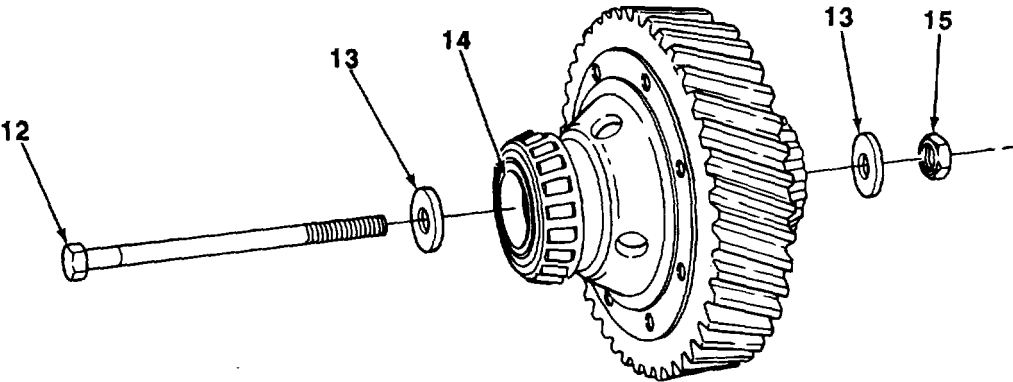

- 6. Install no-spin differential assembly (14) into differential case (18) half.
- 7. Install other differential case (18) half and assemble the differential case halves, matching scribe marks made during disassembly, with four bolts (20) and nuts (21).
- 8. Check to ensure that parts within differential case (18) rotate freely and that there is no binding.
- 9. If removed, install two bearings (17) and spacers (16) on ends of differential case (18).
- 10. Remove nut (15), two washers (13), and bolt (12) from no-spin differential assembly (14).

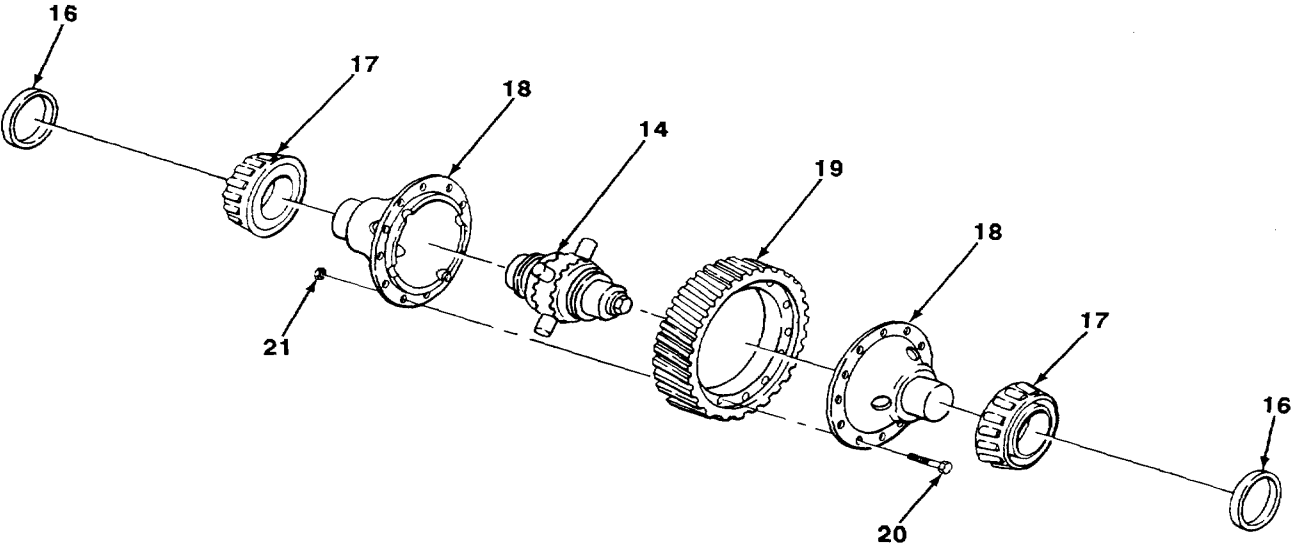

9-1. FORWARD-REAR DIFFERENTIAL MAINTENANCE (Con't).

- 11. Install remaining eight bolts (20) and nuts (21). Torque 12 bolts to 148-190 lb.-ft. (201-258 N•m).
- 12. Install new lockwire to hold 12 nuts (21) in place (see paragraph 1-21).

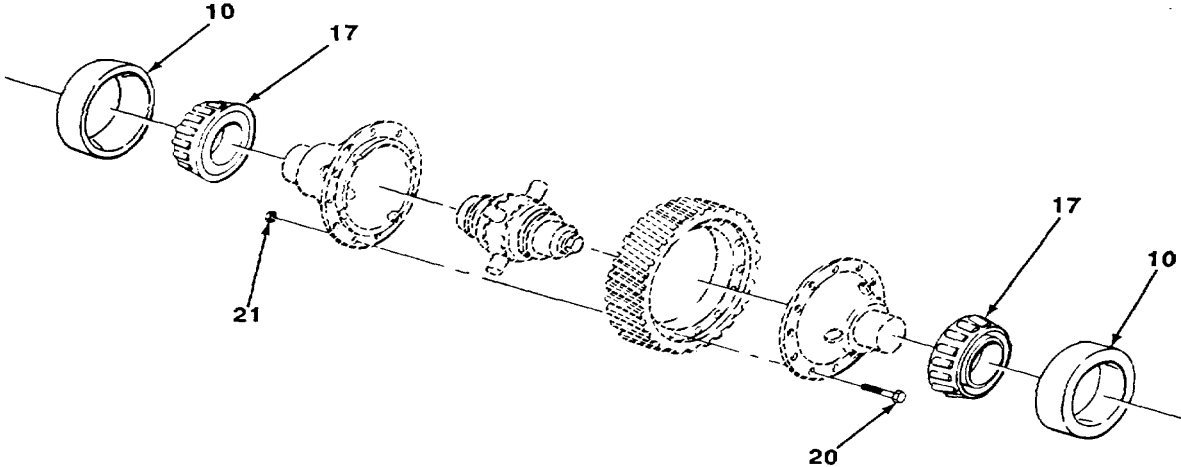

- 13. Temporarily Install bearing cap (9) on legs of differential carrier (2) with two bolts (8). Torque bolts to 300 lb.-ft. (407 N•m).

NOTE
Bearing races must have hand push fit in bores. If bearing races are not hand push fit, bores must be reworked with a scraper or abrasive cloth.

- 14. Hand push bearing race (10) into bore created in differential carrier (2).
- 15. Remove bearing race (10) and bolts (8) from legs of differential carrier (2).
- 16. Repeat steps 13 through 15 for other side.

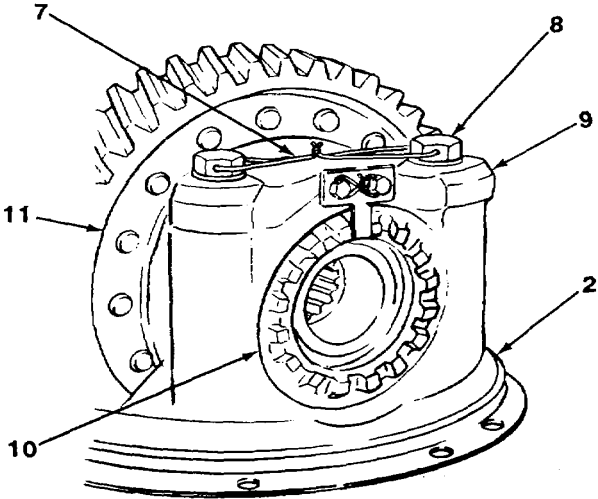

TA703951

9-1. FORWARD-REAR DIFFERENTIAL MAINTENANCE (Con't).

17. Install two bearing races (10) on differential case bearings (17).
18. Install differential (11) into differential carrier (2).
19. Install two bearing caps (9) on legs of differential carrier (2) with four bolts (8). Torque bolts to 300 lb.-ft. (407 N•m).
20. Install new lockwire (7) securing bolts (8) bearing caps (9) (see paragraph 1-21).

I. DIFFERENTIAL CARRIER INSTALLATION

Install new gasket (3) and differential carrier (2) to forward-rear axle housing (5) with 18 new lockwashers (6) and nuts (1).

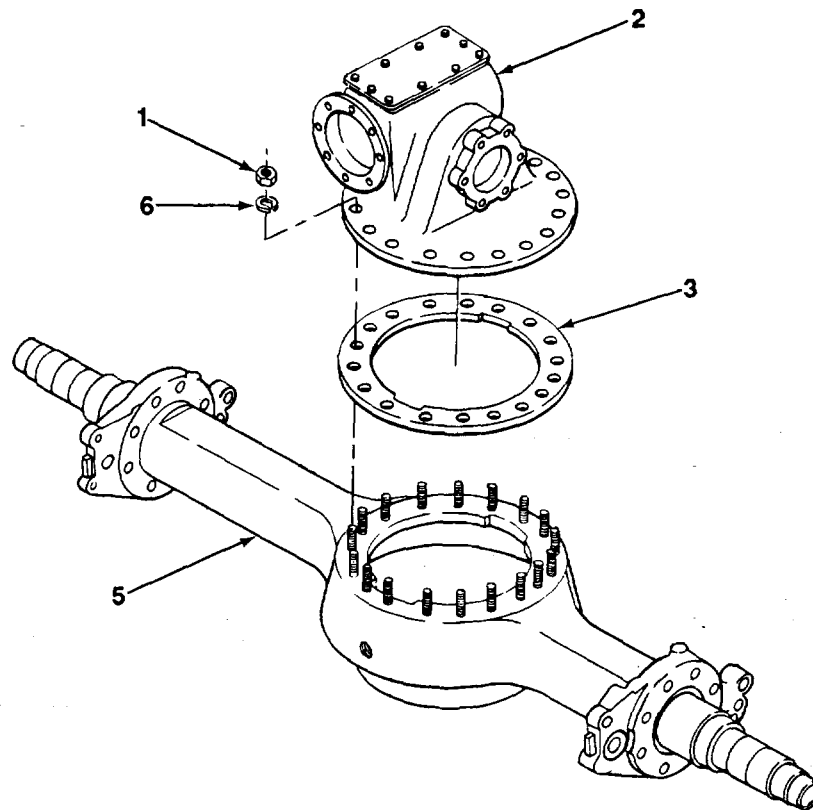
**FOLLOW-ON TASKS:**

- Install interaxle differential (see paragraph 9-2).
- Install forward-rear axle shafts (see paragraph 8-3).
- Install forward-rear axle (see paragraph 8-3).
- Fill forward-rear differential (see LO 5-3805-254-12).

TA703952

9-2. INTERAXLE DIFFERENTIAL MAINTENANCE.

This Task Covers:

- | | |
|--|---|
| <ul style="list-style-type: none"> a. Removal b. Interaxle Differential Assembly and Housing Disassembly c. Gear Set Pinion Assembly and Case Disassembly d. Cleaning and Inspection | <ul style="list-style-type: none"> e. Gear Set Pinion Assembly and case Assembly f. Interaxle Differential Assembly and Housing Assembly g. Installation |
|--|---|

Initial Setup:

Equipment Conditions:

- Forward-rear axle removed (see paragraph 8-3).
- Interaxle differential drained (see TM 5-3805-254-20).

Tools/Test Equipment:

- General mechanic's tool kit
- Field automotive shop set

References:

- TM 9-214

Materials/Parts:

- Lubricating oil (Item 13, Appendix B)
- Prussian blue paste (Item 15, Appendix B)
- Rags (Item 17, Appendix B)
- Dry cleaning solvent (Item 23, Appendix B)
- Marker tags (Item 25, Appendix B)
- Twine (Item 32, Appendix B)
- Two cotter pins
- Three gaskets
- Ten lockwashers

Personnel Required: Two

General Safety Instructions:

- Dry cleaning solvent is flammable and must not be used near open flame. Use only in a well-ventilated area.

a. REMOVAL

1. Remove cotter pin (2) from input shaft (9). Discard cotter pin.
2. Loosen, but do not remove input shaft nut (1).

NOTE

One bolt is longer than the others. Note location of longer bolt for installation.

3. Remove eight bolts (8), washers (7), and lift differential housing (4) from case (5).
4. Remove gasket (6) from differential housing (4). Discard gasket.
5. Remove power divider differential air shift chamber (see paragraph 9-3).

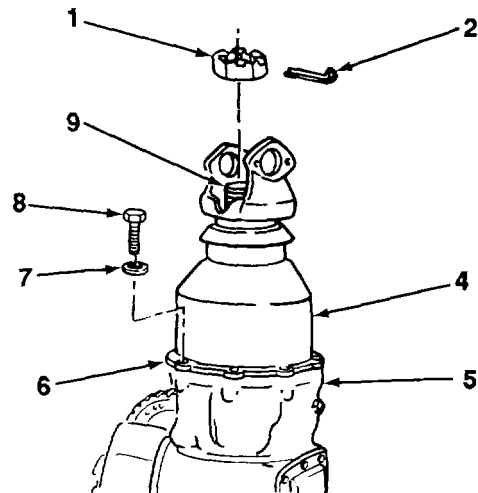

TA703953

9-2. INTERAXLE DIFFERENTIAL MAINTENANCE (Con't).

6. Remove four bolts (12), shift fork housing (13), and gasket (11) from case (5). Discard gasket.

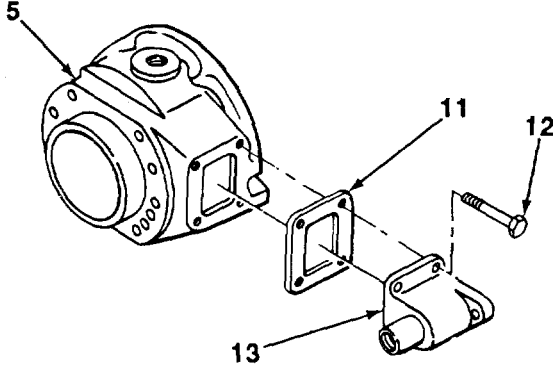

7. Remove cotter pin (19) from bolt (17) and nut (18). Discard cotter pin.

8. Remove bolt (17), spring (16), washer (15), nut (18), and shifter fork (14) from case (5). Do not disturb adjusting screw at this time.

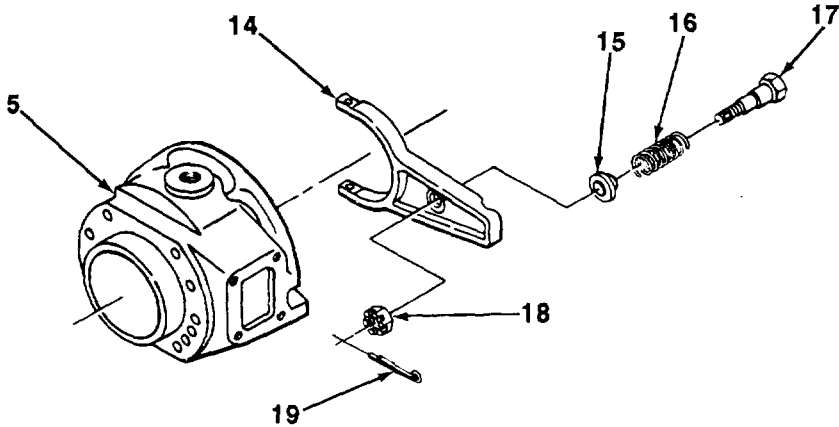

9-2. INTERAXLE DIFFERENTIAL MAINTENANCE (Con't).

9. Remove shift collar (23) from gear set pinion (22).

NOTE

- Some bolts are longer than others. There are three long bolts and five short bolts attaching case to forward-rear axle housing. Note location of bolts for installation.
- Gear set pinion assembly will still be installed when case is removed from forward-rear axle housing.
- Shim(s) are placed between case and forward-rear axle housing. Tag shims for installation.

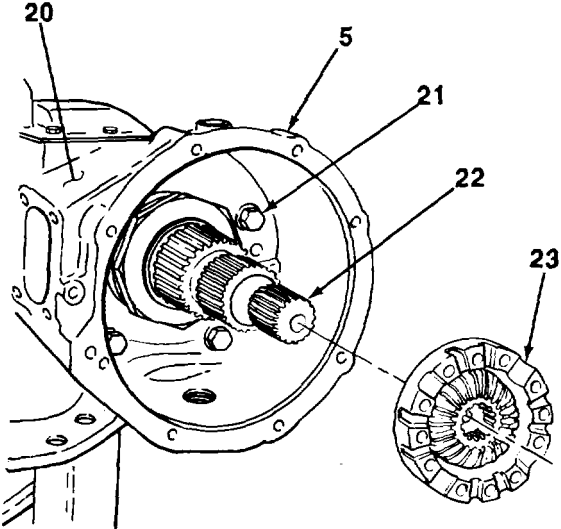

10. Remove eight bolts (21) and pull case (5) with assembled gear set pinion (22) and shim(s) (20) from forward-rear axle housing.

b. INTERAXLE DIFFERENTIAL ASSEMBLY AND HOUSING DISASSEMBLY

1. Remove Input shaft nut (1), washer (10), and yoke (3) from input shaft (9).
2. Press differential assembly (24) from differential housing (4).

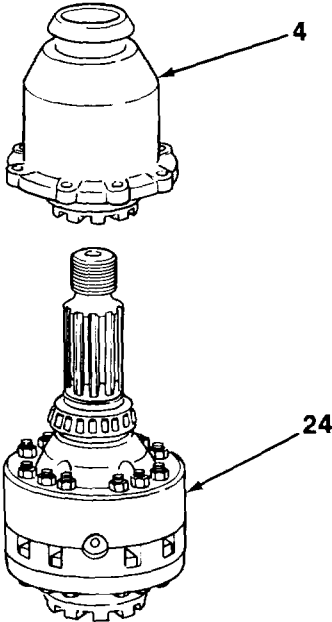
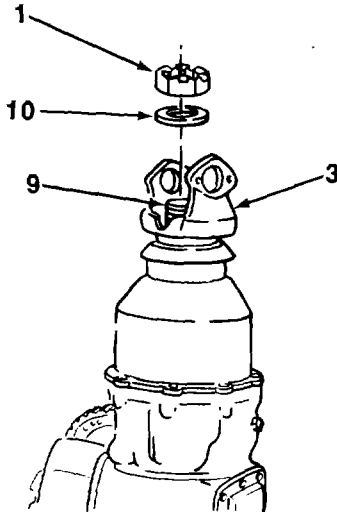

9-2. INTERAXLE DIFFERENTIAL MAINTENANCE (Con't).

- 3. Place an alignment mark on intermediate, forward, and rear differential assembly case (27, 36, and 38) for proper alignment during assembly.
- 4. Remove 12 bolts (25), washers (26), and nuts (35) from differential assembly (24).
- 5. Remove oil scoop (34) from forward differential assembly case (36).
- 6. Carefully remove forward differential assembly case (36) from intermediate differential assembly case (27).
- 7. Remove forward thrustwasher (37) from forward differential assembly case (36).
- 8. Remove two side gears (29), spider (30), four pinion gears (31), and four thrustwashers (32) from rear differential assembly case (38).
- 9. Remove rear thrustwasher (28) from rear differential assembly case (38).
- 10. Remove intermediate differential assembly case (27) from rear differential assembly case (38).
- 11. If damaged, remove bearing (33) from input shaft (9).

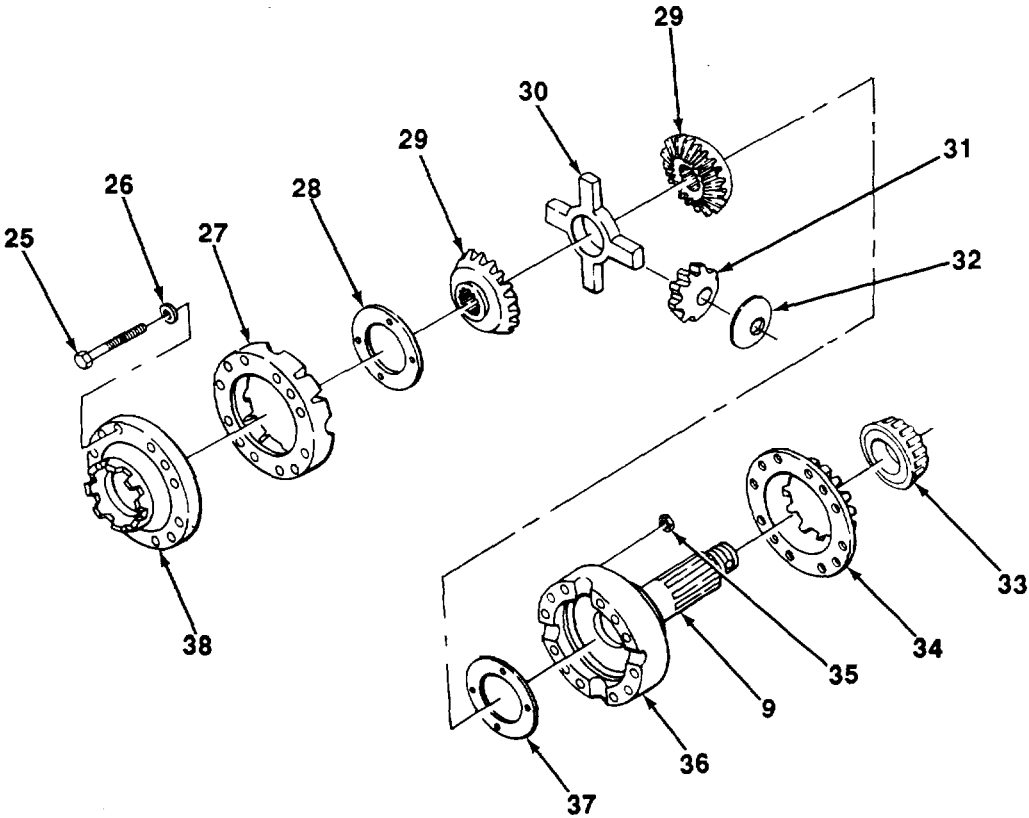

9-2. INTERAXLE DIFFERENTIAL MAINTENANCE (Con't).

c. GEAR SET PINION ASSEMBLY AND CASE DISASSEMBLY

- 1. Secure case (5) with assembled gear set pinion (22) in soft-jawed vise.
- 2. Straighten tab on pinion bearing washer (46).
- 3. Remove pinion bearing jamnut (45), pinion bearing washer (46), adjusting nut spacer plate (47), and inner adjusting nut (48) from gear set pinion (22).
- 4. Press gear set pinion (22) from case (5).
- 5. Remove pinion bearing spacer (51) from gear set pinion (22).
- 6. Remove fork adjustment nut (44) and fork adjusting screw (52) from case (5).
- 7. If damaged, remove bearings (42 and 49), bearing cups (43 and 50), and bearing spacer (51).
- 8. If bearing (40) is damaged, remove snapping (39), bearing, and retaining ring (41) from gear set pinion (22).

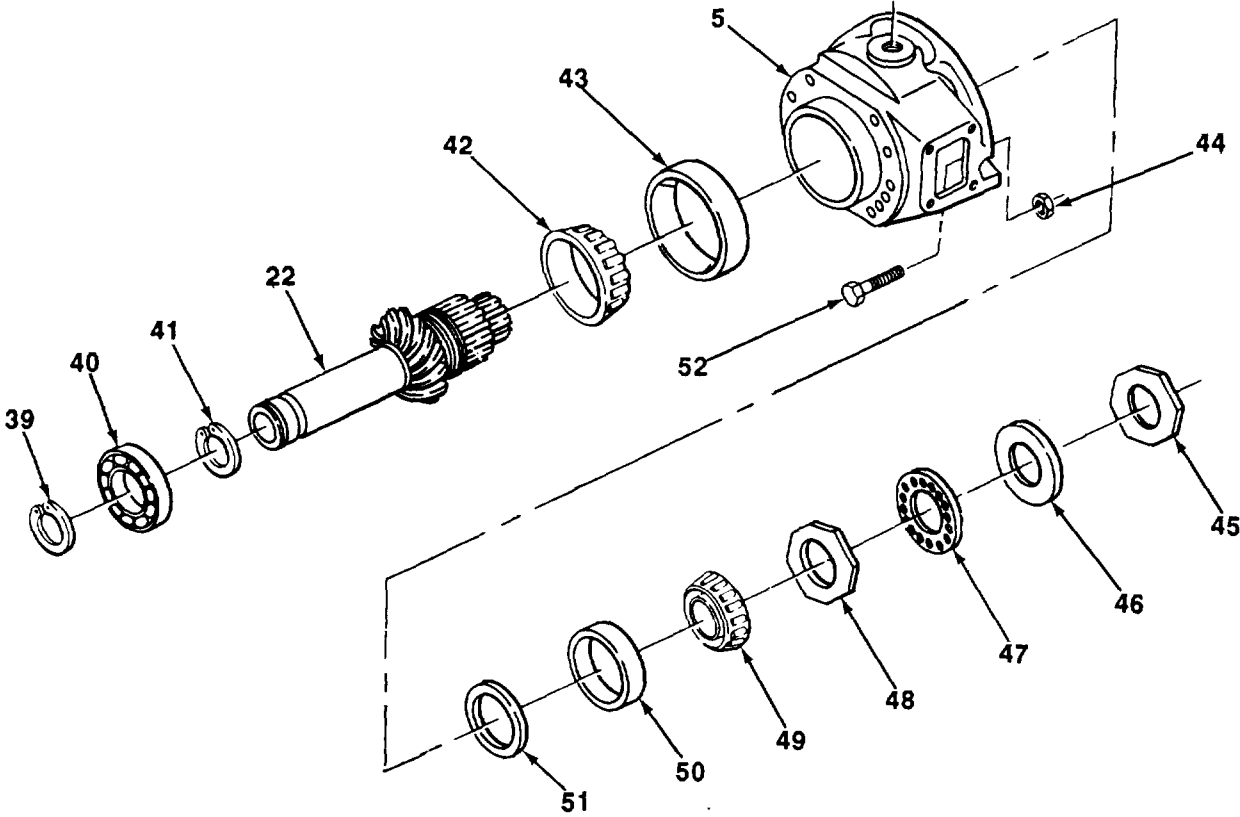

9-2. INTERAXLE DIFFERENTIAL MAINTENANCE (Con't).**d. CLEANING AND INSPECTION****WARNING**

Dry cleaning solvent, P-D-680, is toxic and flammable. Always wear protective goggles and gloves, and use only in a well-ventilated area. Avoid contact with skin, eyes, and clothes, and DO NOT breathe vapors. DO NOT use near open flame or excessive heat. The solvent's flash point is 100°F-138°F (38°C-59°C). If you become dizzy while using cleaning solvent, immediately get fresh air and medical help. If solvent contacts eyes, immediately wash your eyes and get medical aid.

1. Clean all metal parts with dry cleaning solvent and allow to air dry.
2. Inspect housing and case for cracks or damage.
3. Inspect shifter fork for cracks or distortions.
4. Inspect all gears and pinion splines for burrs and damage.
5. Inspect seal (57) for damage. If damaged, remove seal from differential housing (4). Discard seal.

NOTE

Do not remove bearing or bearing cups unless damaged.

6. Inspect bearing (56) and bearing cups (53 and 55) (see TM 9-214).
7. If damaged, remove bearing (56) from differential housing (4) using bearing puller.
8. If damaged, remove two bearing cups (53 and 55) from differential housing (4) using puller.
9. If removed, install bearing cups (53 and 55) and bearing (56) in differential housing (4).
10. Inspect seal (54) for damage. If damaged, remove seal from differential housing (4). Discard seal.
11. If removed, install new seals (54 and 57) into differential housing (4).

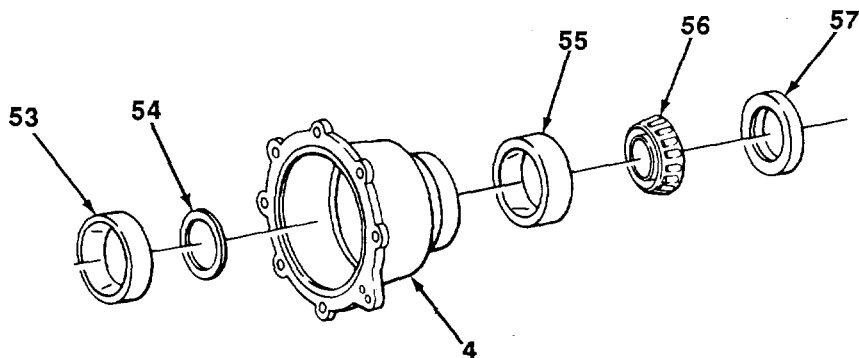

9-2. INTERAXLE DIFFERENTIAL MAINTENANCE (Con't).

e. GEAR SET PINION ASSEMBLY AND CASE ASSEMBLY

NOTE

Lubricate all components with lubricating oil during Installation.

- 1. If removed, install new retaining ring (41), bearing (40), and new snapping (39) on gear set pinion (22).
- 2. If removed, install bearing spacer (51), bearing cups (43 and 50), and bearings (42 and 49).
- 3. Install fork adjusting screw (52) and fork adjusting nut (44) into case (5).
- 4. Install pinion bearing spacer (51) onto gear set pinion (22).
- 5. Press gear set pinion (22) into case (5).

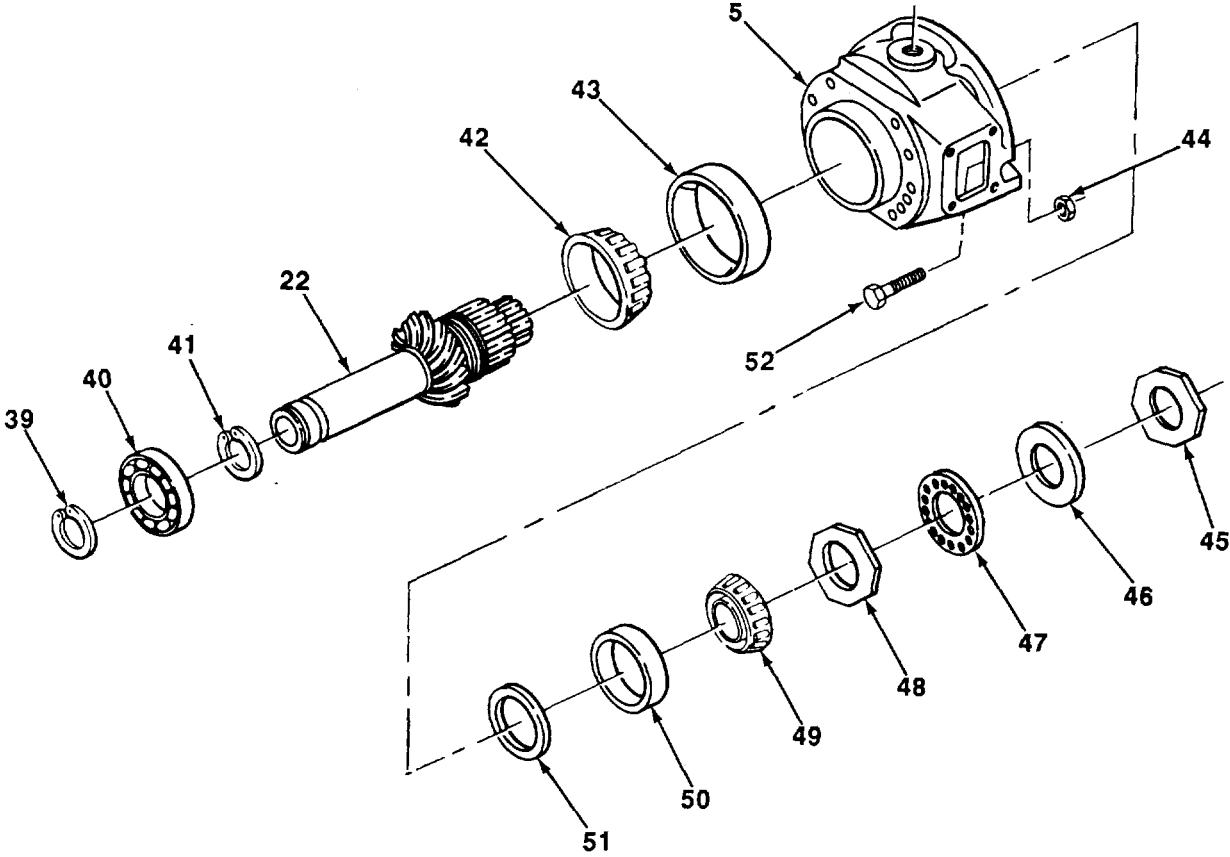

9-2. INTERAXLE DIFFERENTIAL MAINTENANCE (Con't).

6. Wrap twine (58) around gear set pinion (22).
7. Apply 9 tons (8 t) of pressure on gear set pinion (22) and measure preload by pulling on twine (58) with a spring scale.
8. Preload should be 5-15 lb.-in. (7-20 N-m) of rotating torque, not starting torque.

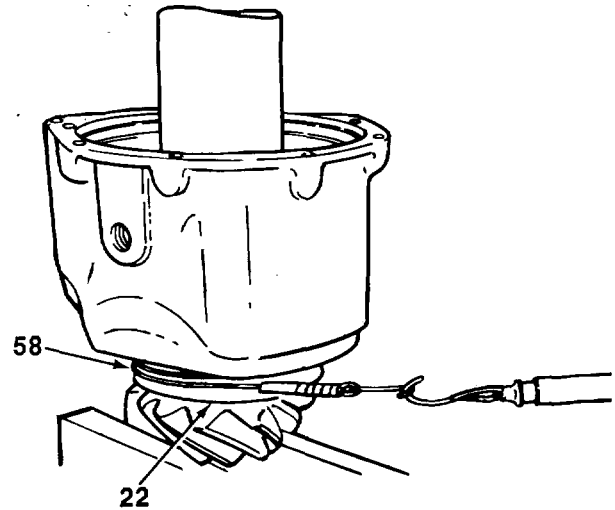

9. If preload is not correct, replace pinion bearing spacer (51) with a thinner spacer to increase torque, or thicker spacer to decrease torque.
10. Install inner adjusting nut (48), adjusting nut spacer plate (47), pinion bearing washer (46), and pinion bearing jamnut (45). Torque pinion bearing jamnuts to 1100 lb.-ft. (1492 N•m), using torque multiplier.
11. Bend tab on pinion bearing washer (46) to secure pinion bearing jamnut (45).

TA703960

9-2. INTERAXLE DIFFERENTIAL MAINTENANCE (Con't).

f. INTERAXLE DIFFERENTIAL ASSEMBLY AND HOUSING ASSEMBLY

NOTE

Lubricate all components with lubricating oil during installation.

- 1. If removed, install bearing (33) on input shaft (9).
- 2. Install intermediate differential assembly case (27) to rear differential assembly case (38) ensuring that alignment marks made during disassembly are aligned.
- 3. Install rear thrustwasher (28) into rear differential assembly case (38).
- 4. Install four pinion gears (31) and thrustwashers (32) on spider (30).
- 5. Install two side gears (29) and assembled spider (30) into rear differential assembly case (38).
- 6. Install forward thrustwasher (37) into forward differential assembly case (36).
- 7. Install forward differential assembly case (36) onto intermediate differential assembly case (27) ensuring that alignment marks made during disassembly are aligned.
- 8. Install oil scoop (34), 12 washers (26), bolts (25), and nuts (35) to differential assembly (24). Torque bolts to 120 lb.-ft. (163 N•m).

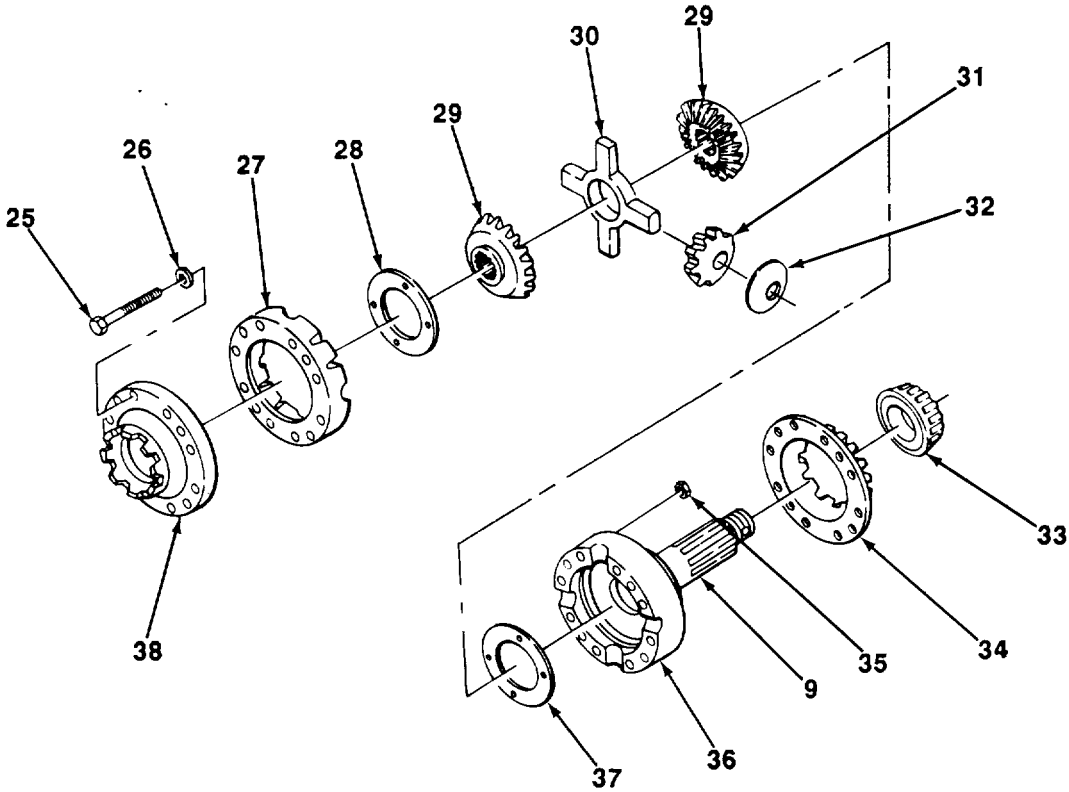

9-2. INTERAXLE DIFFERENTIAL MAINTENANCE (Con't).

9. Press differential assembly (24) into differential housing (4) until internal bearing seats.

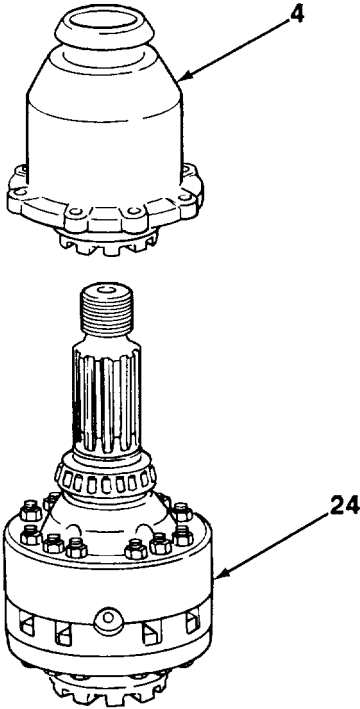

10. Install yoke (3), washer (10), and input shaft nut (1) onto input shaft (9). Do not tighten Input shaft nut.

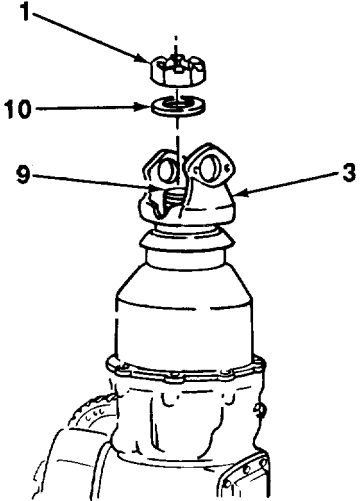

9-2. INTERAXLE DIFFERENTIAL MAINTENANCE (Con't).

e. INSTALLATION

NOTE

- Ensure that three long bolts and five short bolts,1 identified during removal are Installed In correct locations.
- Ensure that same number and size shim(s) are Installed between case and forward-rear axle housing.

1. Install case (5) with assembled gear set pinion (22) and shims(s) (20) onto forward-rear axle housing, ensuring that gear set pinion meshes with drive gear. Install four bolts (21) only.

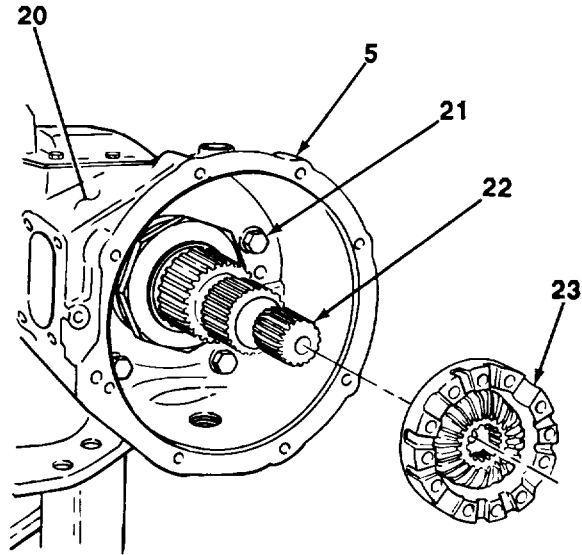

2. If present, remove ten screws (60), lockwashers (59), cover (61), and gasket (62) from forward-rear axle differential carrier (63). Discard gasket and lockwashers.

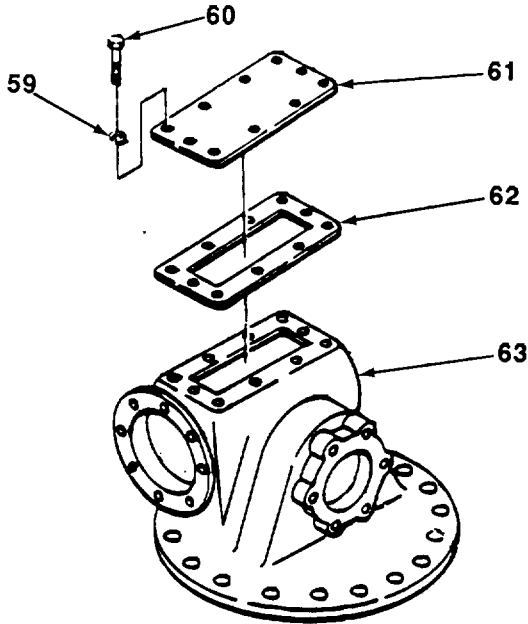

3. Coat drive gear teeth with Prussian blue paste. Turn gear set pinion (22) and drive gear.

4. High contact indicates gear set pinion (22) is too far out. Remove shims (20) to move gear set pinion in.

5. Low contact indicates gear set pinion (22) is too deep. Add shims (20) to move gear set in.

6. Install new gasket (62) and cover (61) to forward-rear axle differential carrier (63). Torque screws to 40 lb.-ft (54 Nom) with ten new lockwashers (59) and screws (60).

7. Install four remaining bolts (21). Torque eight bolts to 100 lb.-ft. (136 N•m).

8. Install shift collar (23) onto gear set pinion (22).

9-2. INTERAXLE DIFFERENTIAL MAINTENANCE (Con't).

- 9. Install shifter fork (14) into case (5) with washer (15), spring (16), bolt (17), and nut (18).
- 10. Install new cotter pin (19) into nut (18) and bolt (17).

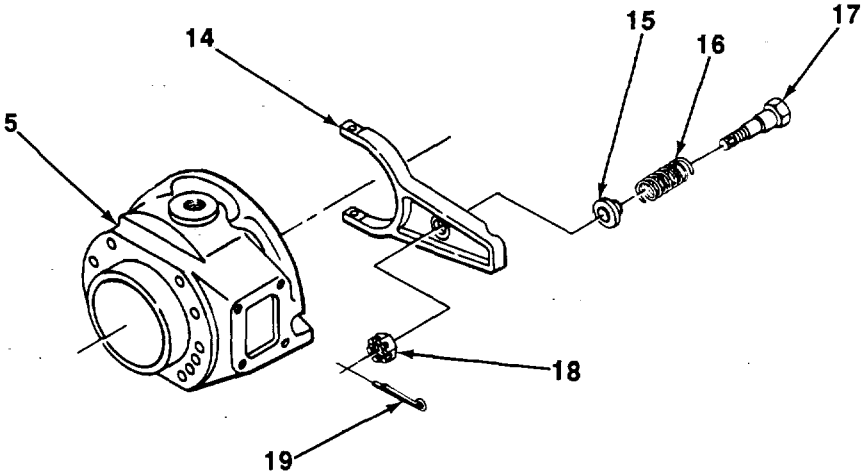

- 11. Install new gasket (11) and shift fork housing (13) to case (5) with four bolts (12).
- 12. Install power divider differential air shift chamber (see paragraph 9-3).

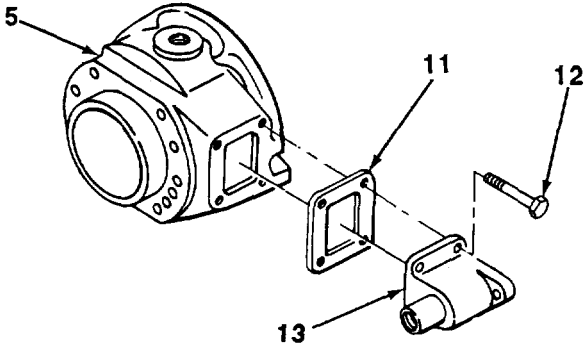

TA703964

9-2. INTERAXLE DIFFERENTIAL MAINTENANCE (Con't).

13. Install new gasket (6) onto case (5).
14. Install differential housing (4) to case (5) with eight washers (7) and bolts (8). Torque bolts to 68 lb.-ft. (92 N•m).
15. Tighten input shaft nut (1) and install new cotter pin (2).

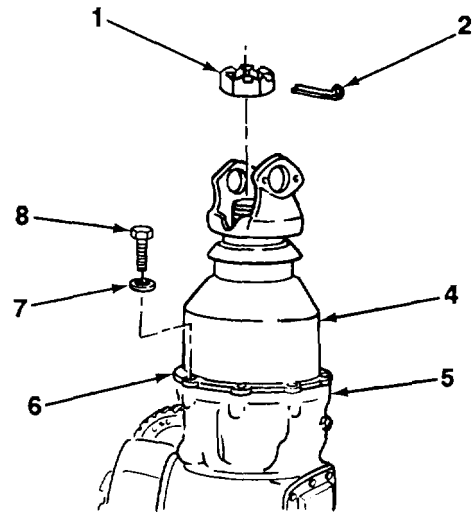
**FOLLOW-ON TASKS:**

- Install forward-rear axle (see paragraph 8-3).
- Fill interaxle differential (see LO 5-3805-254-12).

9-3. POWER DIVIDER DIFFERENTIAL AIR SHIFT CHAMBER MAINTENANCE.

This Task Covers:

- | | |
|----------------------------|-----------------|
| a. Removal | d. Assembly |
| b. Disassembly | e. Installation |
| c. Cleaning and Inspection | |

Initial Setup:

Materials/Parts:

- Rags (Item 17, Appendix B)
- Dry cleaning solvent (Item 23, Appendix B)
- One seal
- One strainer plate
- Two gaskets

Tools/Test Equipment:

- General mechanic's tool kit
- Field automotive shop set

General Safety Instructions:

- Dry cleaning solvent is flammable and must not be used near open flame. Use only in a well-ventilated area.
-

a. REMOVAL

1. Remove air line (4) from elbow (5).
2. Remove four bolts (1), air shift housing (6), and gasket (2) from interaxle differential (3). Discard gasket.

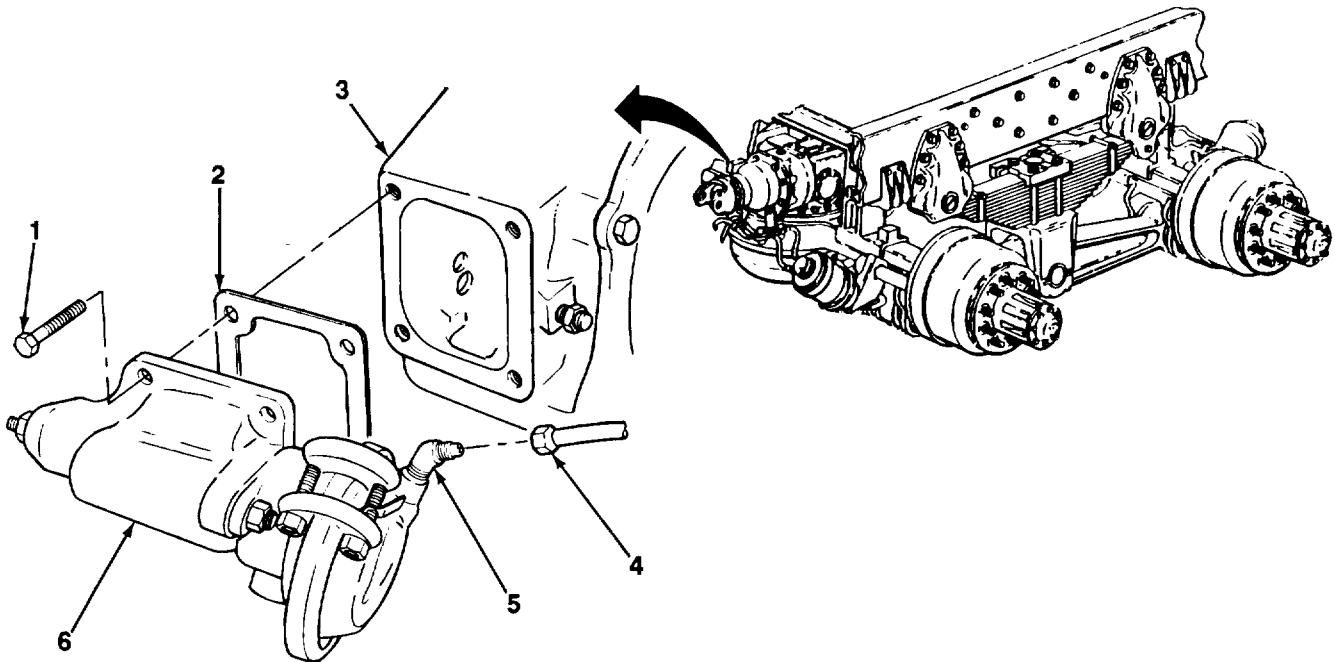

9-3. POWER DIVIDER DIFFERENTIAL AIR SHIFT CHAMBER MAINTENANCE (Con't).**b. DISASSEMBLY**

1. Match-mark air shift chamber half (13) and air shift housing (6).
2. Remove two nuts (23) and washers (22) to loosen air shift chamber halves (7 and 13) from air shift housing (6).
3. Remove snapping (20) from pushrod (16).
4. Remove air shift chamber halves (7 and 13) and gasket (14) from air shift housing (6) as an assembly. Spring (19) will fall free. Discard gasket.
5. Note position of adjusting stud (18) and nut (17) and remove adjusting stud and nut from air shift housing (6).
6. Match-mark air shift chamber halves (7 and 13).
7. Remove two bolts (11), nuts (10), and clamp (12) from air shift chamber halves (7 and 13).
8. Pry air shift chamber halves (7 and 13) apart and remove diaphragm (8).
9. Remove pushrod (16) from air shift chamber half (13).
10. Remove pushrod plate (9) from pushrod (16).
11. Remove elbow (5) from air shift chamber half (7).
12. Using hammer and drift, drive seal (15) out of air shift chamber half (13). Discard drive seal.
13. Pry strainer plate (24) out of air shift chamber half (13). Discard strainer plate.

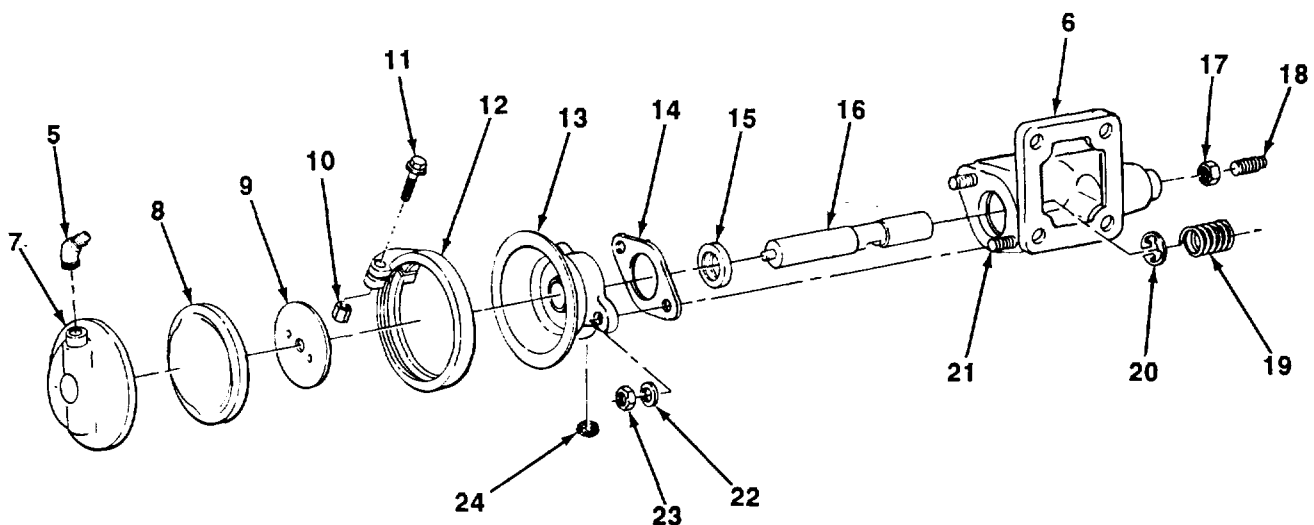

9-3. POWER DIVIDER DIFFERENTIAL AIR SHIFT CHAMBER MAINTENANCE (Con't).

c. CLEANING AND INSPECTION**WARNING**

Dry cleaning solvent, P-D-680, is toxic and flammable. Always wear protective goggles and gloves, and use only in a well-ventilated area. Avoid contact with skin, eyes, and clothes, and DO NOT breathe vapors. DO NOT use near open flame or excessive heat. The solvent's flash point is 1000F-138°F (38°C-590C). If you become dizzy while using cleaning solvent, immediately get fresh air and medical help. If solvent contacts eyes, immediately wash your eyes and get medical aid.

1. Clean all metal parts with dry cleaning solvent, then dry thoroughly with clean, dry rags.
2. Inspect air shift chamber halves, pushrod, pushrod plate, spring, and clamp for cracks, bends, or breaks. Replace if defective.
3. Inspect diaphragm for any holes or tears. Replace if defective.
4. Inspect two studs (21) of air shift housing for damage. Replace if damaged.

d. ASSEMBLY

1. Install new strainer plate (24) into air shift chamber half (13).
2. Press new drive seal (15) into air shift chamber half (13).
3. Install elbow (5) in air shift chamber half (7).
4. Install pushrod (16) through drive seal (15) and into air shift chamber half (13). Install pushrod plate (9) to end of pushrod.
5. Aline match-marks and assemble diaphragm (8) and air shift chamber halves (7 and 13).
6. Install clamp (12), two bolts (11), and nuts (10) to secure air shift chamber halves (7 and 13).
7. Install adjusting stud (18) and nut (17) to air shaft housing (6). Torque nut to 43-56 lb.-ft. (58-76 N•m).
8. Position spring (19) in air shift housing (6) and loosely position new gasket (14) and air shift chamber halves (7 and 13) to air shift housing as an assembly.
9. Install snapping (20) into groove of pushrod (16) closest to air shift chamber halves (7 and 13).
10. Aline match-marks and install air shift chamber halves (7 and 13) to air shift housing (6) with two washers (22) and nuts (23).

9-3. POWER DIVIDER DIFFERENTIAL AIR SHIFT CHAMBER MAINTENANCE (Con't).

e. INSTALLATION

- 1. Install new gasket (2) and air shift housing (6) to interaxle differential (3) with four bolts (1).
- 2. Connect air line (4) to elbow (5).

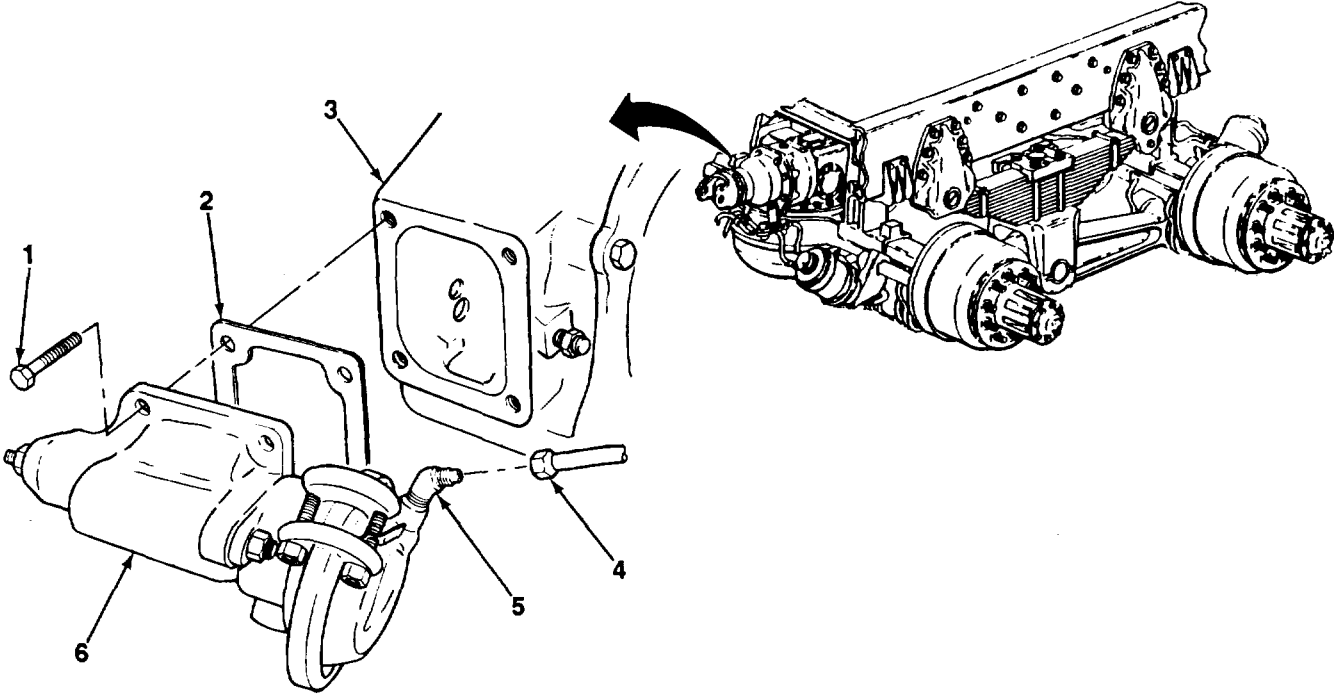

9-4. REAR AXLE POWER DIFFERENTIAL LOCK REPLACEMENT.

This Task Covers:

- a Removal
- b Cleaning and Inspection
- c Installation

Initial Setup:

Equipment Conditions:

- Instrument panel pad removed (TM 5-3805-254-20).
- Airbrake system drained (TM 5-3805-254-10).

Materials/Parts:

- Rags (Item 17, Appendix B)
- Dry cleaning solvent (Item 23, Appendix B)

Tools/Test Equipment:

- General mechanic's tool kit

General Safety Instructions:

- Dry cleaning solvent is flammable and must not be used near open flame. Use only in a well-ventilated area.

a. REMOVAL

1. Disconnect two air lines (4 and 5) from elbows (3 and 6).
2. Remove two screws (8), escutcheon (9), and rear axle power differential lock control valve assembly (2) from left side instrument panel (7).
3. Remove two elbows (3 and 6) and pipe plug (1).

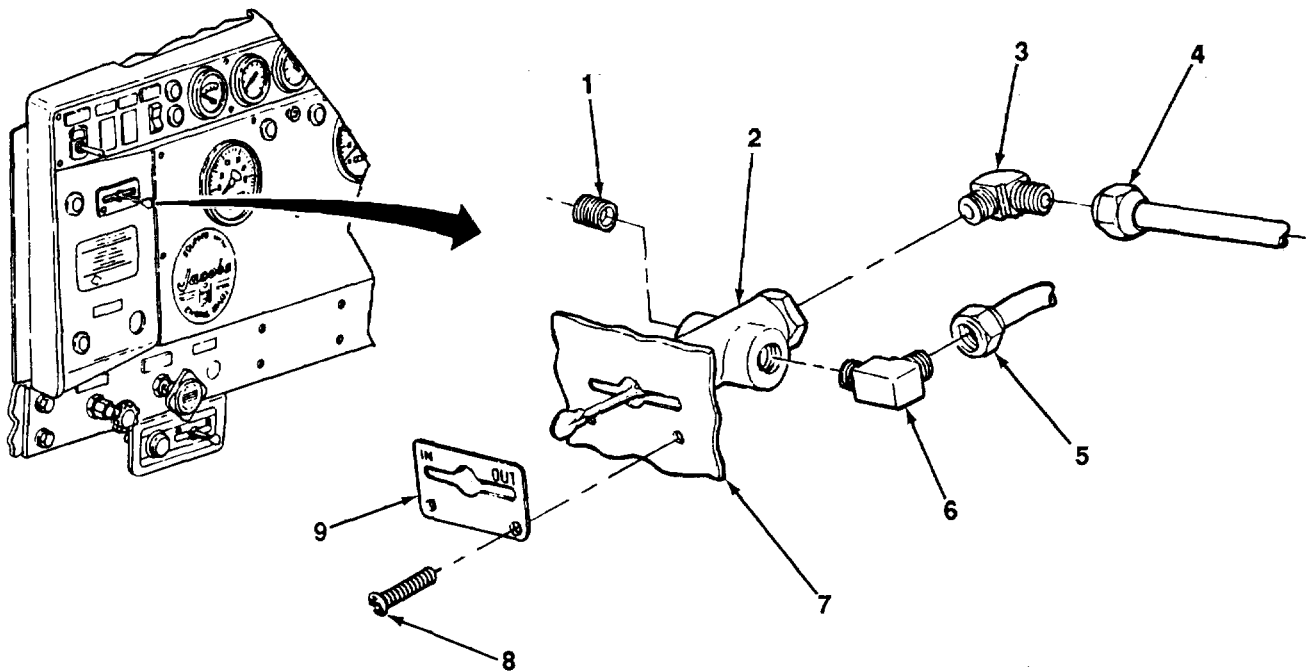

TA703969

9-4. REAR AXLE POWER DIFFERENTIAL LOCK REPLACEMENT (Con't).

b. CLEANING AND INSPECTION I

WARNING

Dry cleaning solvent, P-D-680, is toxic and flammable. Always wear protective goggles and gloves, and use only in a well-ventilated area. Avoid contact with skin, eyes, and clothes, and DO NOT breathe vapors. DO NOT use near open flame or excessive heat. The solvent's flash point is 100°F-138°F (380C-590C). If you become dizzy while using cleaning solvent, immediately get fresh air and medical help. If solvent contacts eyes, immediately wash your eyes and get medical aid.

1. Clean all metal parts with dry cleaning solvent, then dry thoroughly with clean, dry rags.
2. Inspect control valve assembly, escutcheon, elbows, and pipe plug for cracks, breaks, or abnormal bends.

c. INSTALLATION

1. Install two elbows (3 and 6) and pipe plug (1) in rear axle power differential lock control valve assembly (2).
2. Position rear axle power differential lock control valve assembly (2) and escutcheon (9) in place on left side instrument panel (7) and secure with two screws (8).

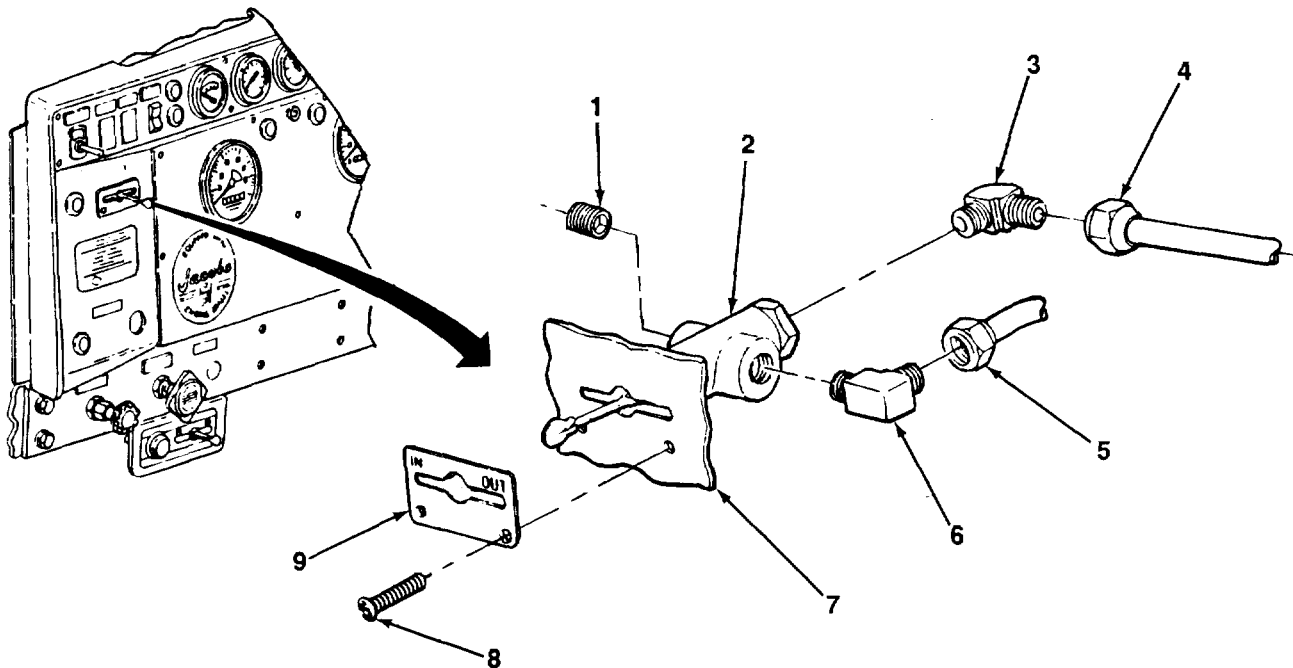

FOLLOW-ON TASKS:

- Install instrument panel pad (see TM 5-3805-254-20).

TA703970

9-5. REAR-REAR DIFFERENTIAL MAINTENANCE

This Task Covers:

- a. Differential Carrier Removal
- b. Differential Removal and Disassembly
- c. Thru Shaft Removal and Disassembly
- d. Cross-shaft Removal and Disassembly
- e. Cleaning and Inspection
- f. Cross-shaft Assembly and Installation
- g. Thru Shaft Assembly and Installation
- h. Differential Assembly and Installation
- i. Differential Carrier Installation

Initial Setup:

Equipment Conditions:

- Rear-rear axle removed (see paragraph 8-4).
- Rear-rear axle shafts removed (see paragraph 8-4).
- Rear-rear differential drained (see TM 5-3805-254-20).

Tools/Test Equipment:

- General mechanic's tool kit
- Field automotive shop set
- Two cross-shaft removal spacers

Personnel Required: Two**References:**

- TM 9-214

General Safety Instructions:

- Dry cleaning solvent is flammable and must not be used near open flame. Use only in a well-ventilated area
-

Materials/Parts:

- Abrasive cloth (Item 4, Appendix B)
- Grease (Item 10, Appendix B)
- Lubricating oil (Item 13, Appendix B)
- Prussian blue paste (Item 15, Appendix B)
- Rags (Item 17, Appendix B)
- Sealing compound (Item 19, Appendix B)
- Dry cleaning solvent (Item 23, Appendix B)
- Marker tags (Item 25, Appendix B)
- Twine (Item 32, Appendix B)
- Nonelectrical wire (Item 34, Appendix B)
- Four gaskets
- Fifty lockwashers

9-5. REAR-REAR DIFFERENTIAL MAINTENANCE (Con't).**a. DIFFERENTIAL CARRIER REMOVAL**

1. Match-mark differential carrier (2) and rear-rear axle housing (5) for assembly.
2. Remove 18 nuts (1) and lockwashers (6) from studs (4) of rear-rear axle housing (5). Discard lockwashers.

NOTE

Removal of assembled carrier may require tapping with mallet to loosen gasket material.

3. Remove differential carrier (2) and gasket (3) from rear-rear axle housing (5). Discard gasket.
4. If damaged, remove 18 studs (4) from rear-rear axle housing (5).

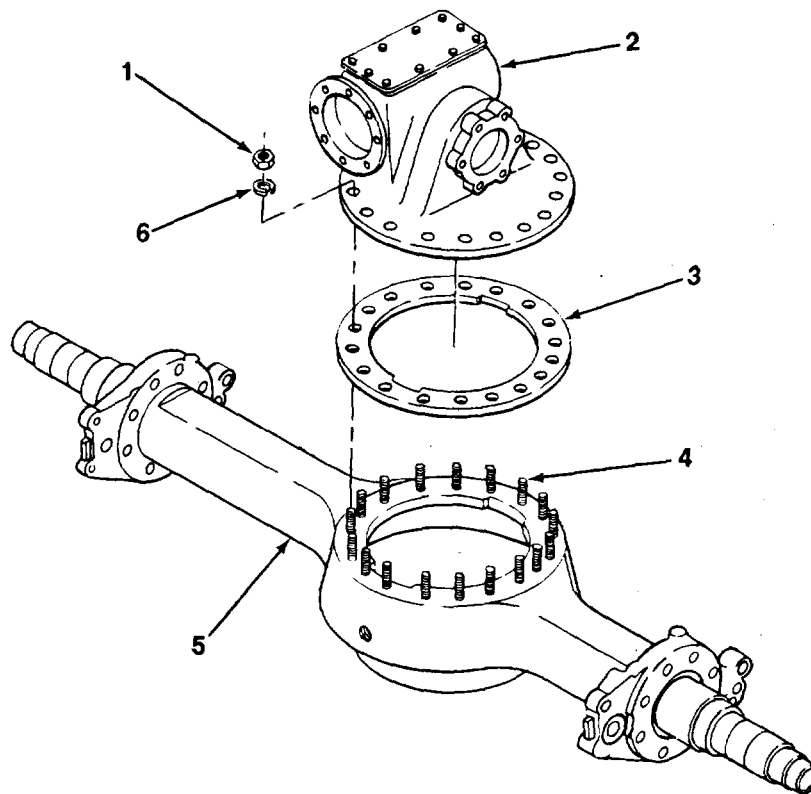

TA703971

9-5. REAR-REAR DIFFERENTIAL MAINTENANCE (Con't).**b. DIFFERENTIAL REMOVAL AND DISASSEMBLY**

1. Mount differential carrier (2) in vise with soft jaw
2. Cut lockwire (7) securing bolts (8) in bearing ca (9). Discard lockwire.
3. Mark bearing cap (9) and legs of differential carries (2) to ensure proper assembly and installation.
4. Remove two bolts (8) and bearing cap (9).
5. Repeat steps 2 through 4 for other bearing cap (9)
6. Lift differential (11) out of differential carrier (2).
7. Remove two bearing races (10) from legs differential carrier (2).

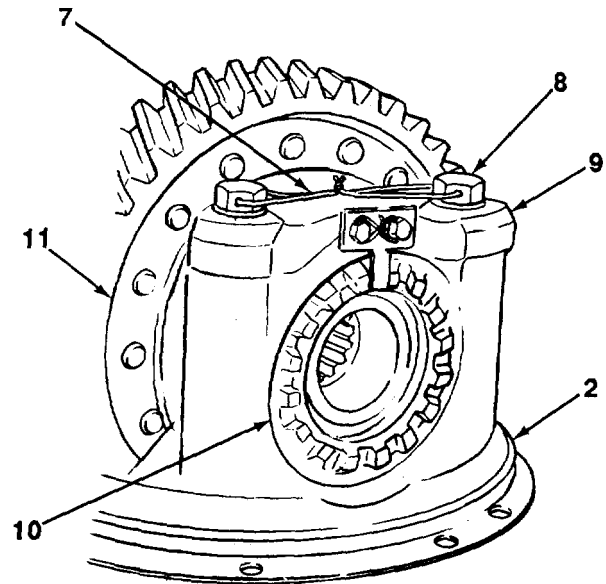
**WARNING**

Tightly hold no-spin differential together to contain spring pressure as differential case is removed. Failure to follow this warning may result in injury to personnel or damage to differential case assembly components.

NOTE

Bolt, two washers, and nut used in step 8 should be from shop stock and are used to old no-spin differential assembly together when differential case half is removed.

8. Install bolt (12), two washers (13), and nut (15) through center of no-spin differential assembly (14). Tighten nut fingertight.

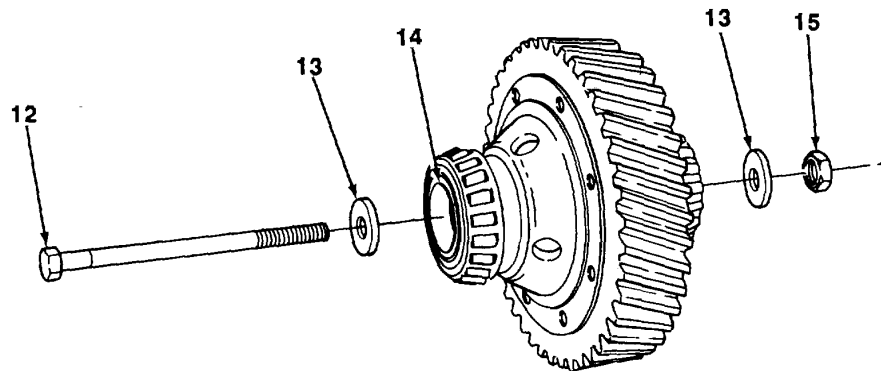

TA703972

9-5. REAR-REAR DIFFERENTIAL MAINTENANCE (Con't).

9. Scribe a line on each half of differential case (18) and driven gear (19) to ensure that assembly is in the same position.
10. Cut lockwire and remove 12 bolts (20) and nuts (21) from differential case (18) halves and driven gear (19). Discard lockwire.
11. Remove one-half of differential case (18).

NOTE

No-spin differential is available as an assembly only. There are no repair parts available. If a part of the differential is damaged, replace complete no-spin differential assembly.

12. Remove no-spin differential assembly (14) from differential case (18) half.
13. If damaged, remove two bearing races (10), differential case bearings (17), and spacers (16).

NOTE

Perform steps 14 through 17 only if disassembly of no-spin differential is required for inspection purposes.

14. Install no-spin differential assembly (14) in arbor press.

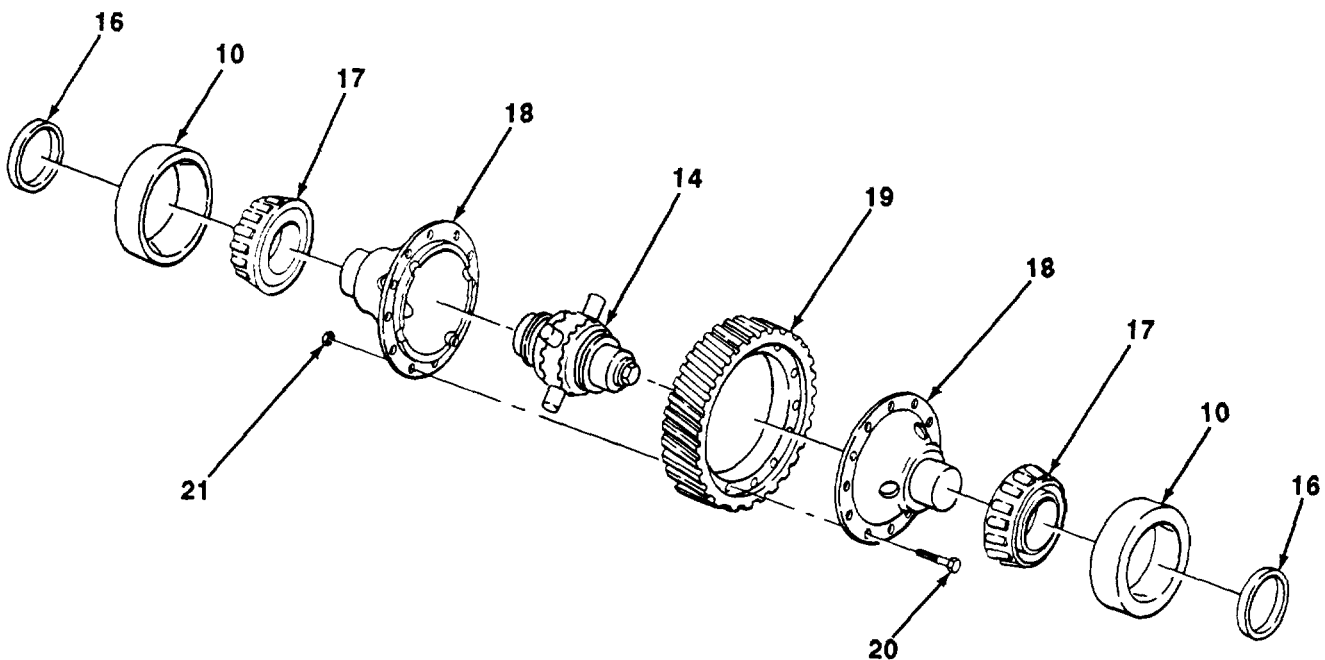

TA703973

9-5. REAR-REAR DIFFERENTIAL MAINTENANCE (Con't).

- 15. Press on head of bolt (12) to release spring pressure against nut (15) and remove nut and washer (13).
- 16. Slowly release pressure and allow assembly to separate until spring pressure is fully released.
- 17. Remove bolt (12), washer (13), two side gears (22), springs (23), spring retainers (24), and drive gears (25) from spider (26).

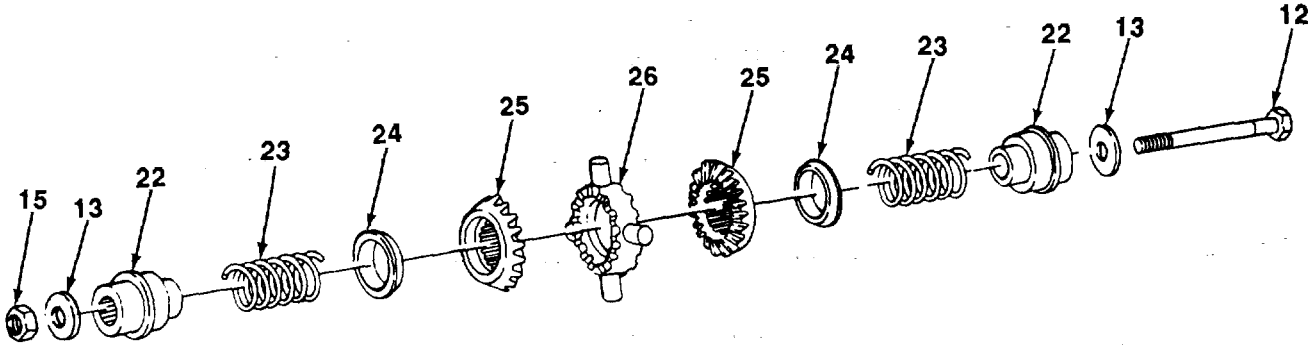

c. THRU SHAFT REMOVAL AND DISASSEMBLY

- 1. Remove six screws (27), lockwashers (28), cover (29), and gasket (30) from differential carrier (2). Discard gasket and lockwashers.

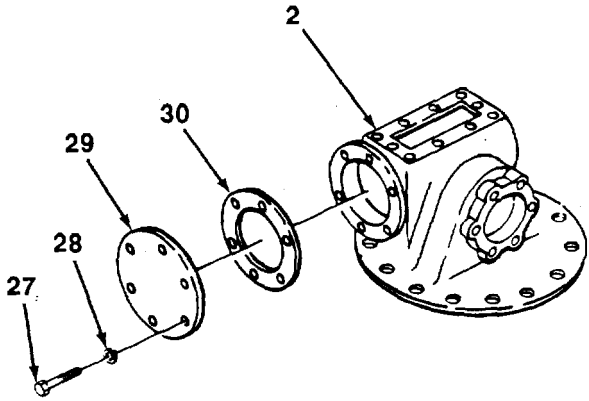

9-5. REAR-REAR DIFFERENTIAL MAINTENANCE (Con't).

2. Remove pinion bearing retainer (40) and adjusting washer (39) from differential carrier (2).
3. Remove eight bolts (38), lockwashers (37), bearing cage (36), and shims (35) from differential carrier (2). Attach shims to bearing cage for installation. Discard lockwashers.
4. Remove spacer (34) from gear and pinion assembly (31).
5. If damaged, remove bearings (32 and 41) and bearing races (33 and 42) from pinion assembly (31).

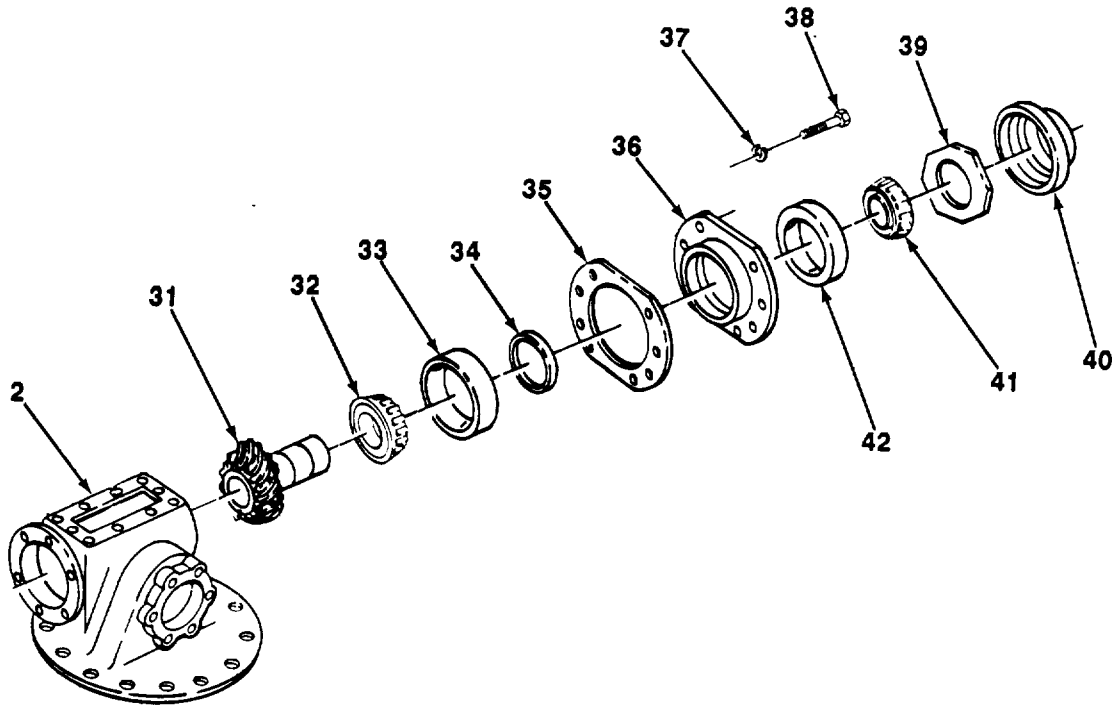

TA703975

9-5. REAR-REAR DIFFERENTIAL MAINTENANCE (Con't).

- 6. Tap thru shaft (45) out of differential carrier (2).
- 7. If damaged, remove two snaprings (43), space (46), and thru shaft bearing (44).

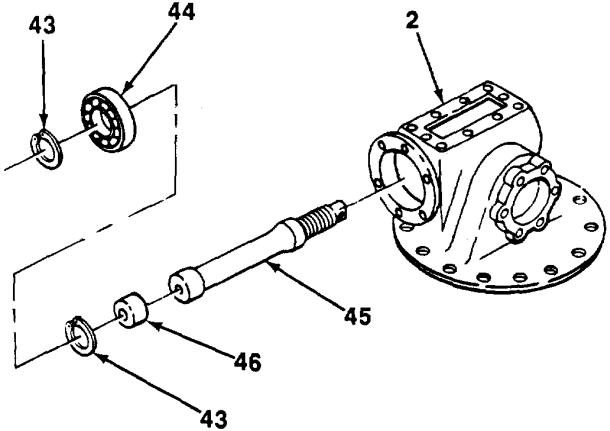

d. CROSS-SHAFT REMOVAL AND DISASSEMBLY }

- 1. Remove ten screws (48), lockwashers (47), cover (49), and gasket (50) from differential carrier (2). Discard gasket and lockwashers.
- 2. Cut lockwire from bolt heads and remove six bolts (53), bearing retainer plate (52), and shims (51) from differential carrier (2). Attach shims to bearing retainer plate for installation. Discard lockwire.

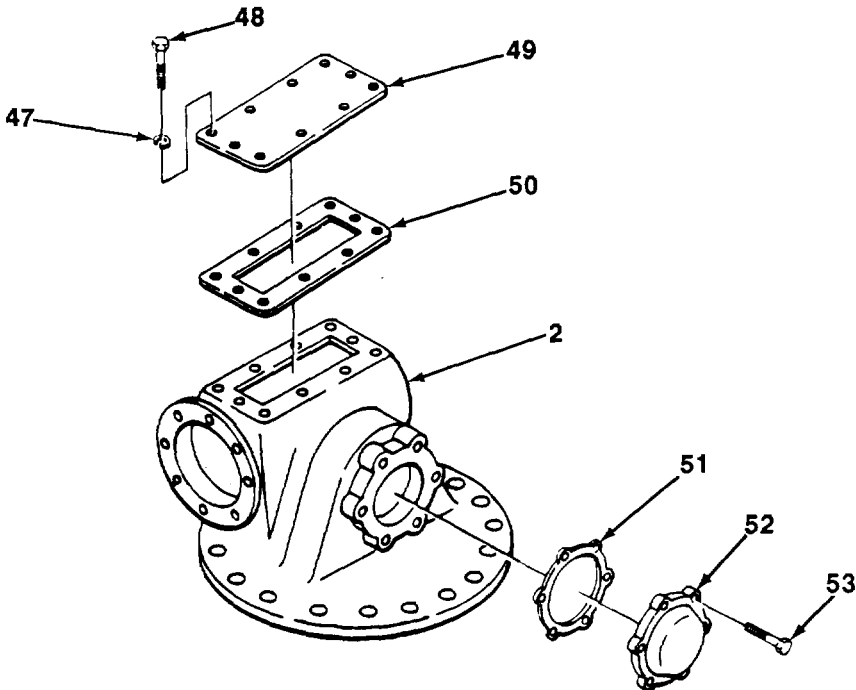

9-5. REAR-REAR DIFFERENTIAL MA

- Remove eight bolts (57), lockwashers (56), c (54), and gasket (55) from differential carrier (2). Discard lockwashers and gasket.

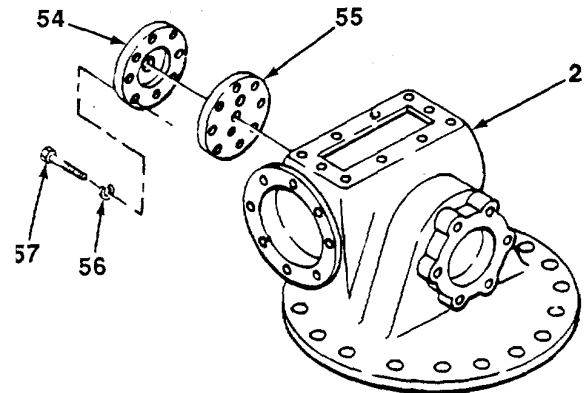

NOTE

Bearings and bearing races will remain inside bearing housing during step 4. These will be removed in subparagraph e only if damaged.

- Remove bearing housing (59) and shims (58) from differential carrier (2). Attach shims to bearing housing to ensure that same number are installed.

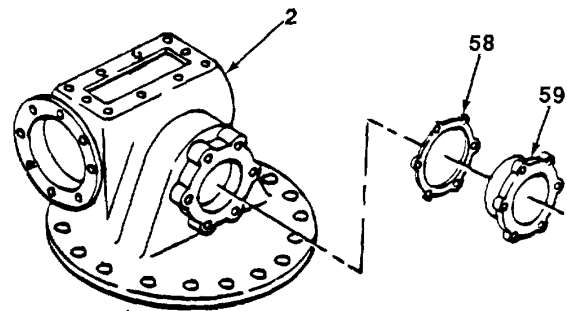

- Tap cross-shaft (60) and ring gear set (61) toward thru shaft chamber of differential carrier (2).

- Install two cross-shaft removal spacers between back of ring gear set (61) and inner of differential carrier (2).

- Press cross-shaft (60) from differential carrier

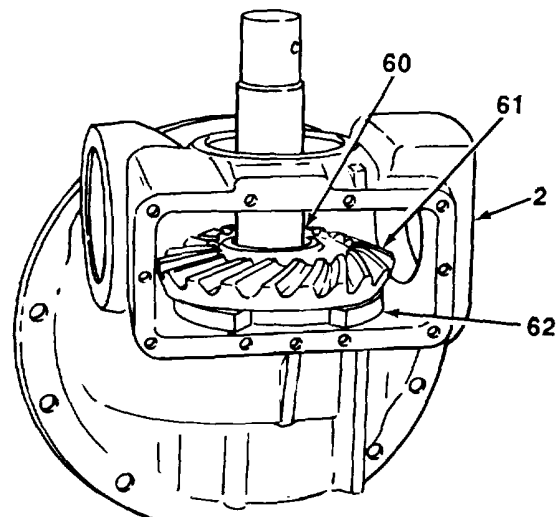

9-5. REAR-REAR DIFFERENTIAL MAINTENANCE (Con't).

8. Remove key (65) from cross-shaft (60).
9. Remove two cross-shaft removal spacers (62) from differential carrier (2).
10. Cut lockwire and remove three screws (67) and adjusting washer (66) from cross-shaft (60). Discard lockwire.
11. Press out ring gear set (61) and bearing (64) as a unit, and remove from differential carrier (2). Do not lose recessed washer (63).
12. Remove recessed washer (63) if it did not come loose during removal of ring gear set (61).
13. If damaged, remove bearing (64) from ring gear set (61).

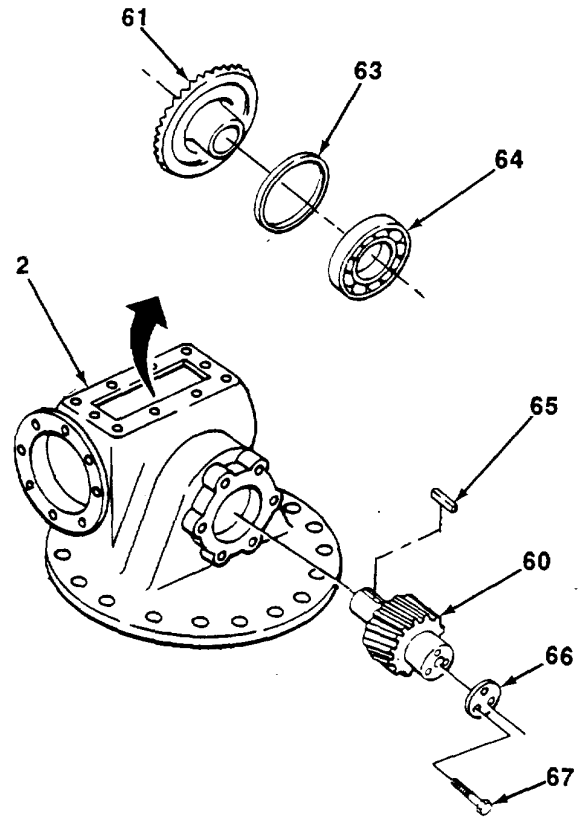
**e. CLEANING AND INSPECTION }****WARNING**

Dry cleaning solvent, P-D-680, is toxic and flammable. Always wear protective goggles and gloves, and use only in a well-ventilated area. Avoid contact with skin, eyes, and clothes, and DO NOT breathe vapors. DO NOT use near open flame or excessive heat. The solvent's flash point is 100°F-1380F (380C-59°C). If you become dizzy while using cleaning solvent, immediately get fresh air and medical help. If solvent contacts eyes, immediately wash your eyes and get medical aid.

1. Clean all metal parts with dry cleaning solvent.

NOTE

If one differential case bearing needs to be replaced, replace both differential case bearings.

2. Inspect bearings for damage (see TM 9-214).

TA703978

9-5. REAR-REAR DIFFERENTIAL MAINTENANCE

- 3. Inspect gear bearing sleeve (69) inside differential carrier (2). If damaged, remove setscrew (68) and gear bearing sleeve.
- 4. Press replacement gear bearing sleeve (69) into differential carrier (2). Drill setscrew hole in gear bearing sleeve and install setscrew (68).
- 5. Inspect two bearings (71) and bearing races (70) inside bearing housing (59) (see TM 9-214). If damaged, replace bearings and bearing races.

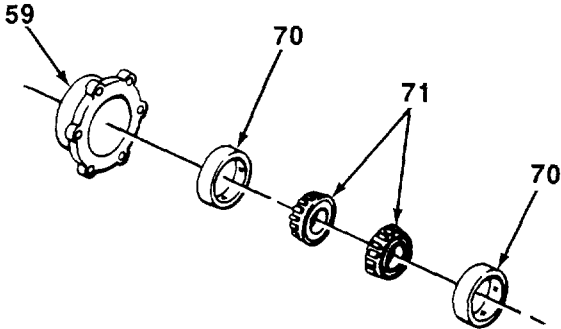
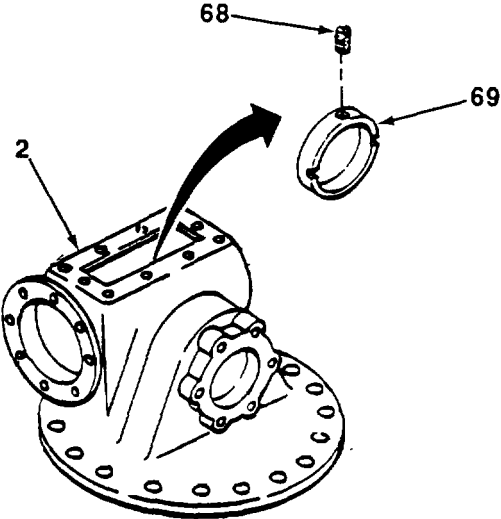

TA703979

9-5. REAR-REAR DIFFERENTIAL MAINTENANCE (Con't).

f. CROSS-SHAFT ASSEMBLY AND INSTALLATION

1. If removed, install bearing (64) on ring gear set (61).
2. Apply grease to center hole of ring gear set (61) and bearing (64).
3. Install ring gear set (61) and recessed washer (63) into differential carrier (2) using two cross-shaft removal spacers (62) to hold assembly away from wall of differential carrier (2).
4. Apply grease to entering shaft of cross-shaft (60).
5. Press cross-shaft (60) and key (65) into ring gear set (61).
6. Remove two cross-shaft removal spacers (62) from differential carrier (2).

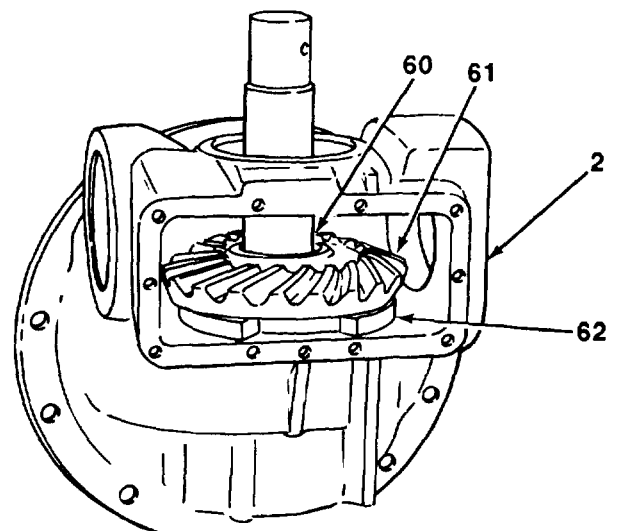
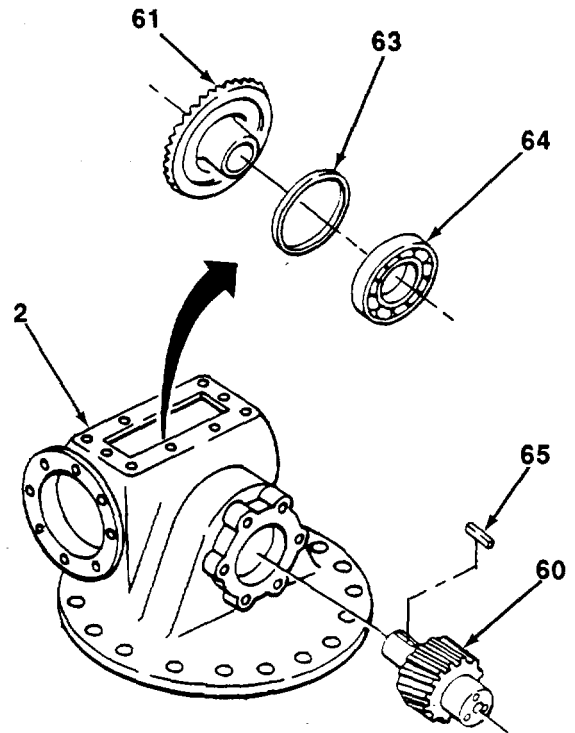

TA703980

9-5. REAR-REAR DIFFERENTIAL MAINTENANCE (Con't).**NOTE****Shims in step 7 control gear backlash**

7. Install original shims (58) over cross-shaft opening (72) in differential carrier (2).
8. Apply grease to bearing journal (73) of cross-shaft (60).
9. Aline bearing housing (59) in differential carrier (2), ensuring that all oil holes are alined. Press bearing housing into differential cover.

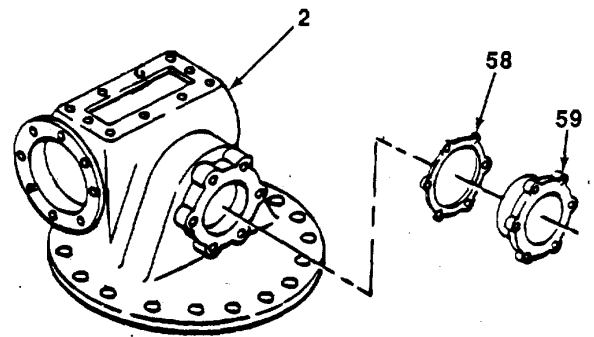
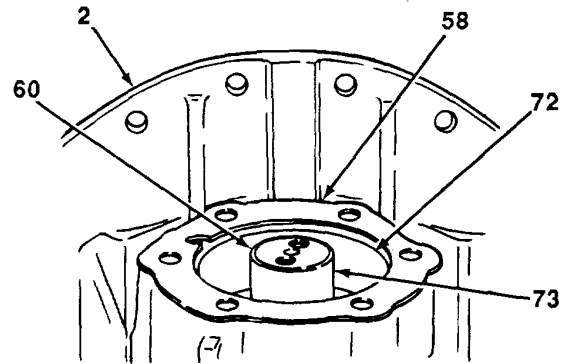

TA703981

9-5. REAR-REAR DIFFERENTIAL MAINTENANCE (Con't).

10. Install adjusting washer (66) on cross-shaft (60) with three screws (67). Torque screws to 69 lb.-ft. (94 N-m). Install new lockwire to screw heads

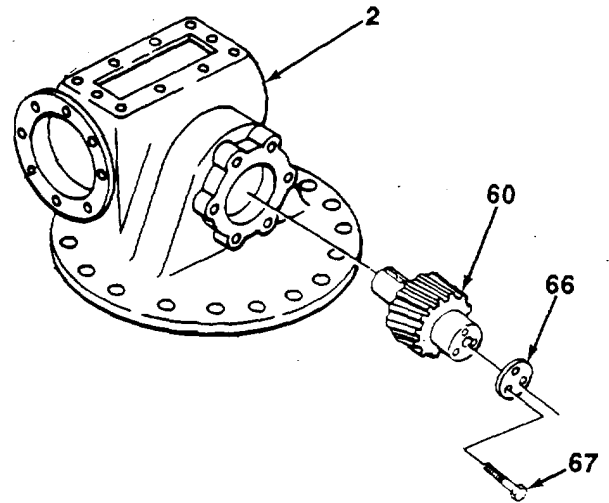
**NOTE**

Shims In step 11 control preload torque.

11. Install original shims (51).
12. Install bearing retainer plate (52) to differential carrier (2) with six bolts (53). Torque bolts to 76 lb.-ft. (103 N-m). Install new lockwire to bolt heads.

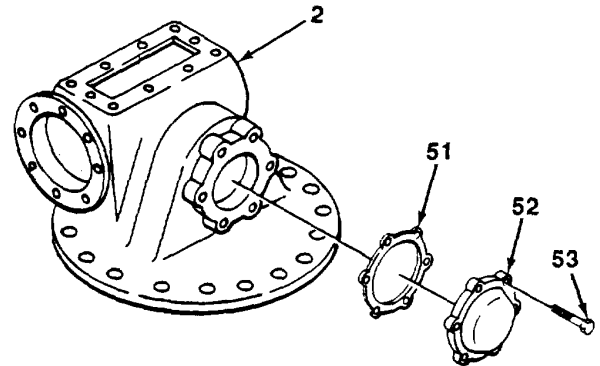

TA703982

9-5. REAR-REAR DIFFERENTIAL MAINTENANCE (Con't).

- 13. Wrap strong twine around pinion (74) of cross-shaft (60) and pull on horizontal line with spring scale. Preload torque should be 5-15 lb.-in. (0.5-1.7 N-m).

- 14. If preload torque is not correct, remove six bolts (53) and bearing retainer plate (52). Add shims (51) to decrease preload torque or remove shims to increase preload torque.

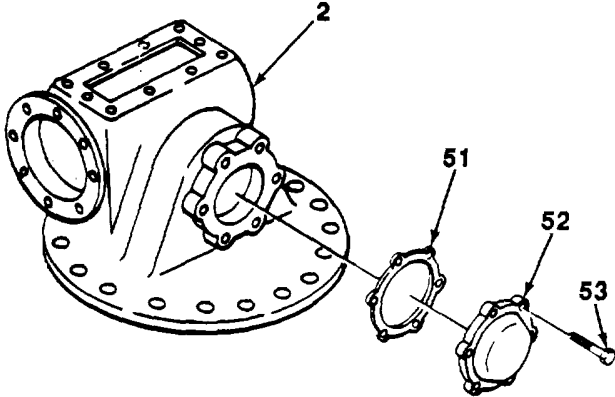
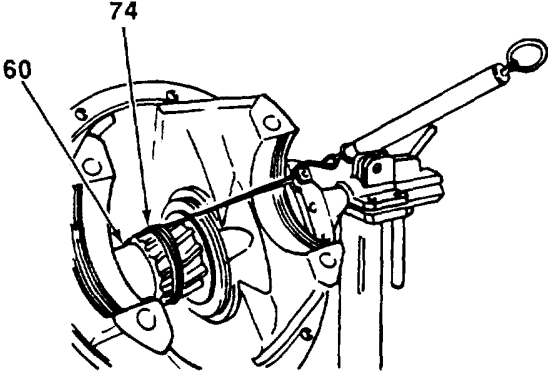

TA703983

9-5. REAR-REAR DIFFERENTIAL MAINTENANCE (Con't).

- 15. Mount dial indicator on side of differential carrier (2).
- 16. Check differential backlash. Backlash should be 0.005-0.015 In. (0.127-0.381 mm).
- 17. If backlash is not correct, remove bearing housing (59) from differential carrier (2) and add shims (58) to decrease backlash, or remove shims to

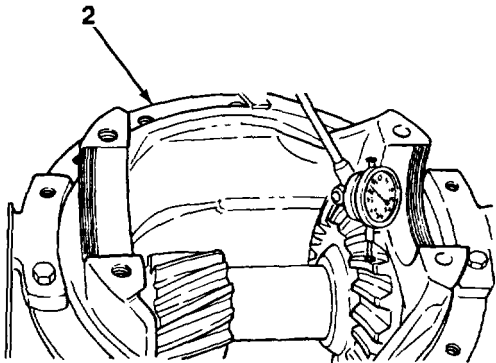

g. THRU SHAFT ASSEMBLY AND INSTALLATION

- 1. If removed, install thru shaft bearing (44) and spacer (46) on thru shaft (45) with two snaprings (43).
- 2. Install thru shaft (45) in differential carrier (2).

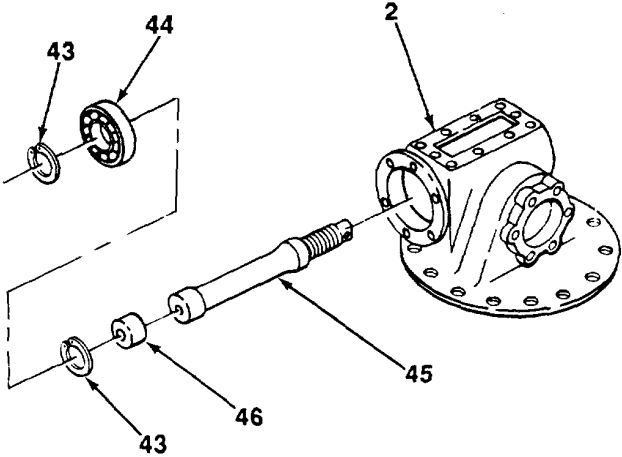
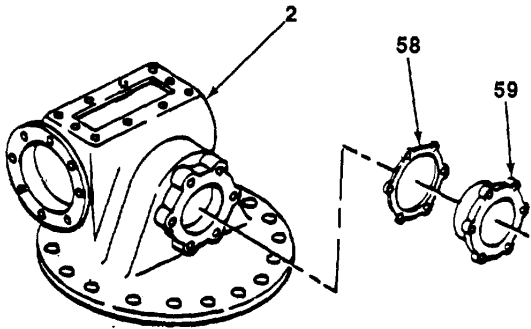

TA703984

9-5. REAR-REAR DIFFERENTIAL MAINTENANCE (Con't). -

- 3. Install spacer (34), bearing races (33 and 42), and bearings (32 and 41) on gear and pinion assembly (31).
- 4. Install original shims (35) and bearing cage (36) with eight new lockwashers (37) and bolts (38).
- 5. Install adjustina washer (39) and Dinion bearina retainer (40) onto differential carrier (2).

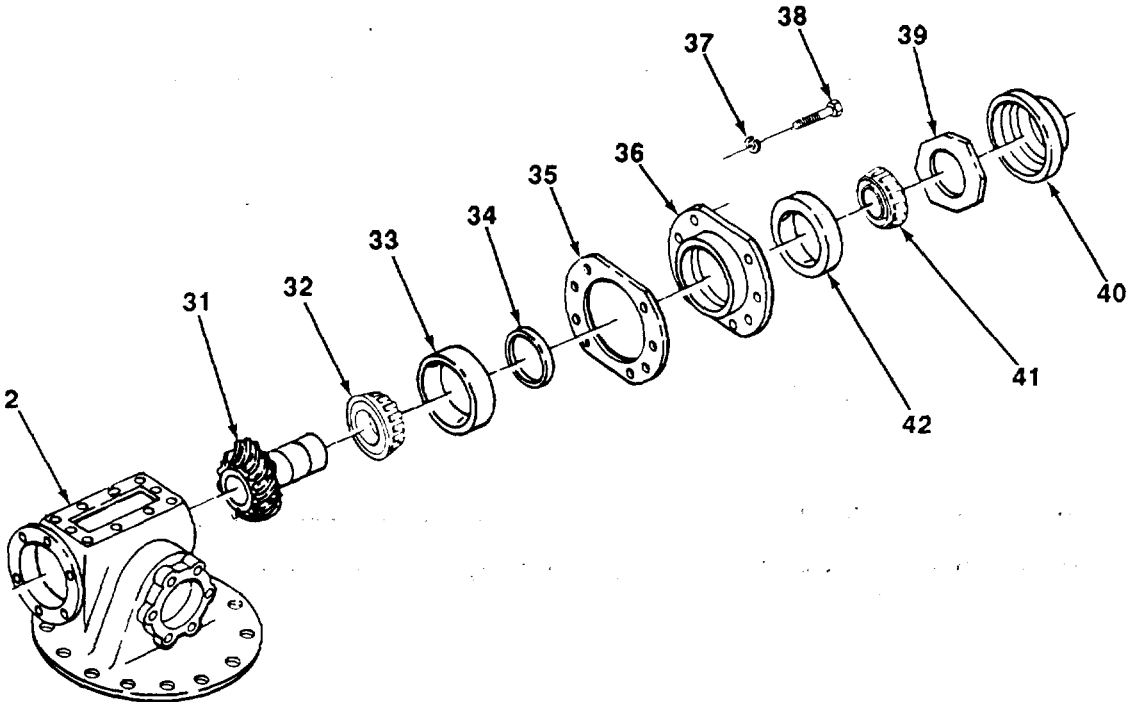

- 6. Install new gasket (30) and cover (29) onto differential carrier (2) with six new lockwashers (28) and screws (27).

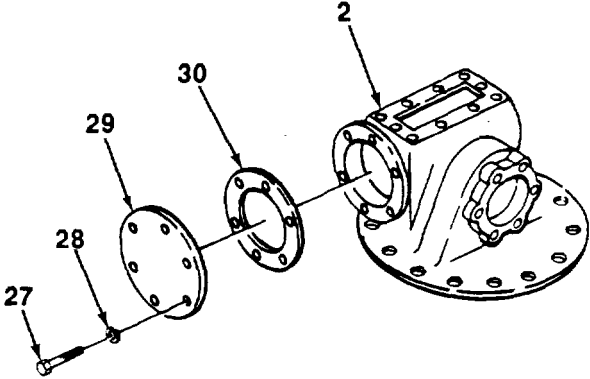

9-5. REAR-REAR DIFFERENTIAL MAINTENANCE (Con't).

- 7. Coat ring gear set (61) teeth with Prussian blue paste.
- 8. Turn gear and pinion assembly (31) and ring gear set (61). High contact indicates gear and pinion assembly is too far out. Remove shims (35) to move gear and pinion assembly in.
- 9. Low contact indicates gear and pinion assembly (31) is too deep. Add shims (35) to move gear and pinion assembly out.

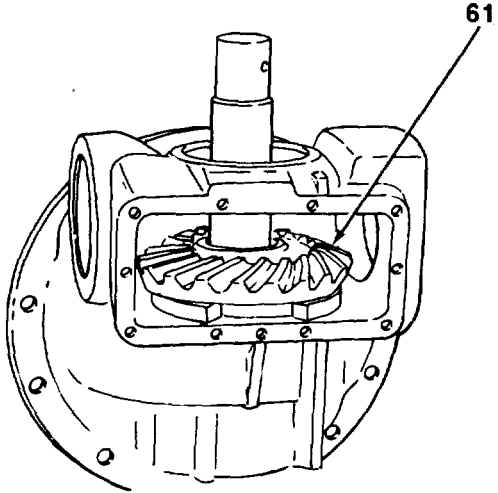

h. DIFFERENTIAL ASSEMBLY AND INSTALLSTION

NOTE

If no-spin differential was disassembled, perform steps 1 through 4. If not, go to step 6.

- 1. Install two drive gears (25), spring retainers (24), springs (23), and side gears (22) on spider (26) and install bolt (12) and washer (13) through center.

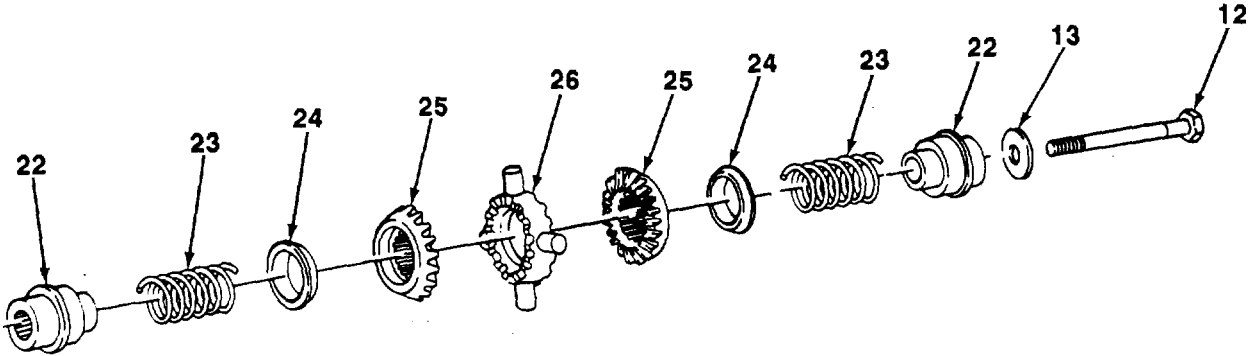

9-5. REAR-REAR DIFFERENTIAL MAINTENANCE (Con't)

2. Place no-spin differential assembly (14) on arbor press.
3. Press on head of bolt (12) and compress no-spin differential assembly (14) slowly. As no-spin differential assembly is compressed, ensure that spines of side gears (22) and drive gears (25) mesh.

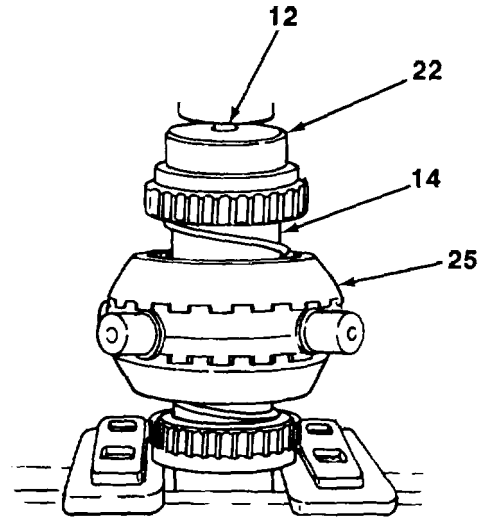

4. Install washer (13) and nut (15) on bolt (12) and remove no-spin differential assembly (14) from arbor press.

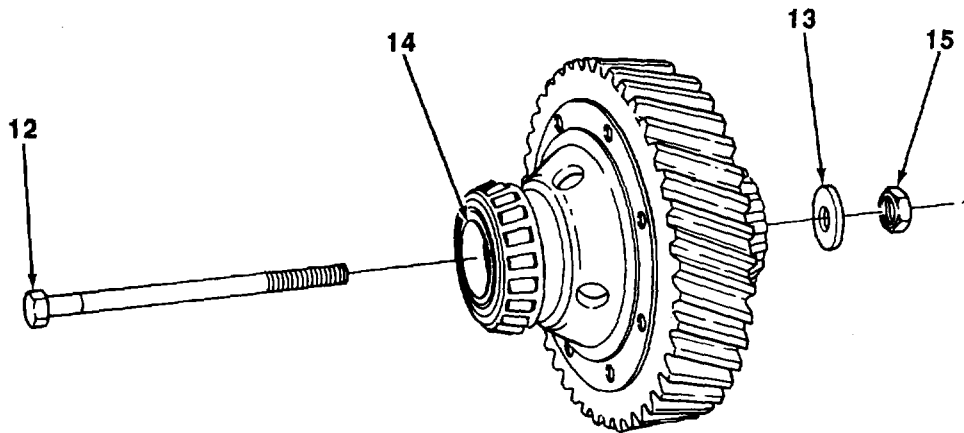

TA703987

9-5. REAR-REAR DIFFERENTIAL MAINTENANCE (Con't).

5. If removed, install two spacers (16), differential case bearings (17), and bearing races (10).
6. Install no-spin differential assembly (14) into differential case (18) half.
7. Install other differential case (18) half and assemble the differential case halves, matching scribe marks made during disassembly. Install four bolts (20) and nuts (21).
8. Check to ensure that parts within differential case (18) rotate freely and that there is no binding.

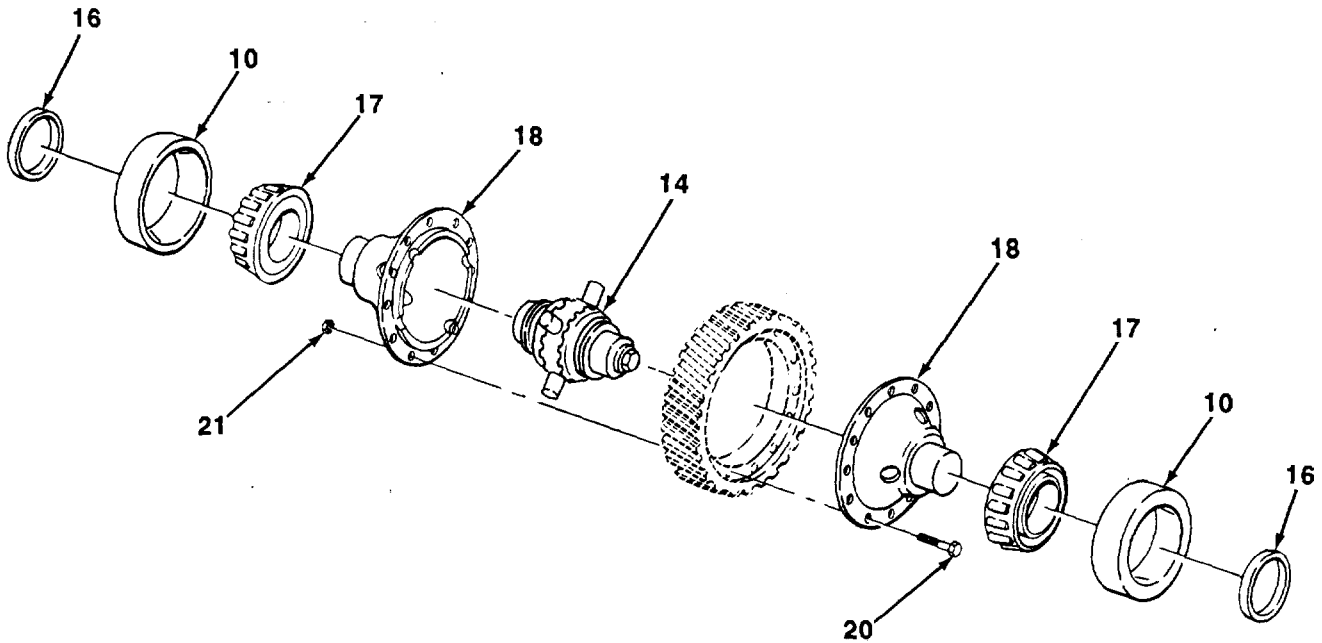

TA703988

9-5. REAR-REAR DIFFERENTIAL MAINTENANCE (Con't).

9. Remove nut (15), two washers (13), and bolt (12) from no-spin differential assembly (14).

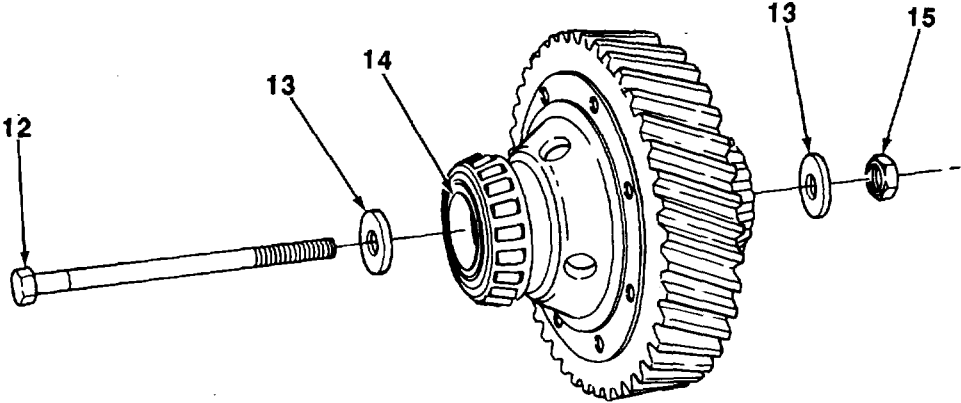

10. Install remaining eight bolts (20) and nuts (21) in differential case (18) halves and driven gear (19). Torque 12 bolts to 148-190 lb.-ft. (201-258 N-m).

11. Install new lockwire to hold 12 nuts (21) in place.

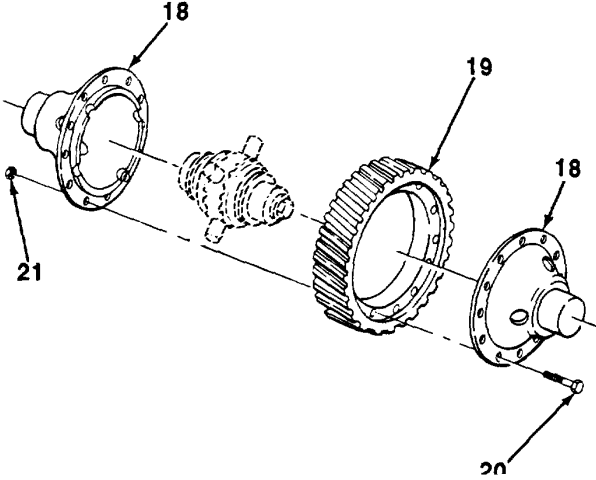

9-5. REAR-REAR DIFFERENTIAL MAINTENANCE (Con't).

12. Temporarily install bearing cap (9) on legs of differential carrier (2) with two bolts (8). Torque bolts to 300 lb.-ft. (407 N-m).

NOTE

Bearing races must have hand push fit in bores. If bearing races are not hand push fit, bores must be reworked with a scraper or abrasive cloth.

13. Hand push bearing race (10) into bore created in differential carrier (2).
14. Remove bearing race (10) and bolts (8) from legs of differential carrier (2).
15. Repeat steps 12 through 14 for other side.
16. Install two bearing races (10) and install differential (11) into differential carrier (2).
17. Install two bearing caps (9) on legs of differential carrier (2) with four bolts (8). Torque bolts to 300 lb.-ft. (407 N-m).
18. Install new lockwire (7) securing bolts (8) in bearing caps (9) (see paragraph 1-21).

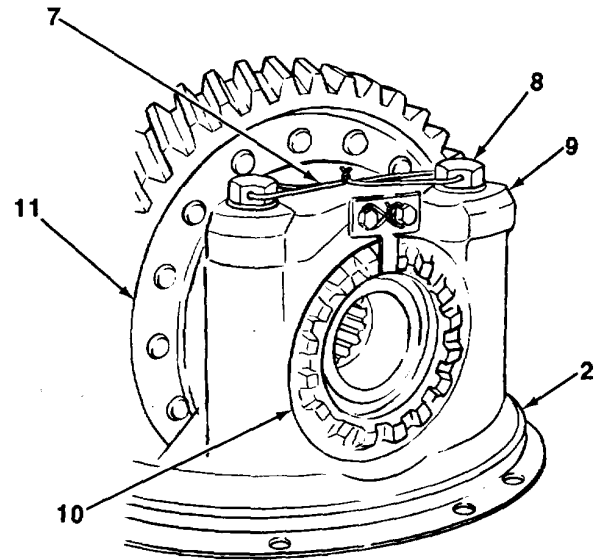

i DIFFERENTIAL CARRIER INSTALLATION |

1. Install new gasket (55) and cover (54) to differential carrier (2) with eight new lockwashers (56) and bolts (57).

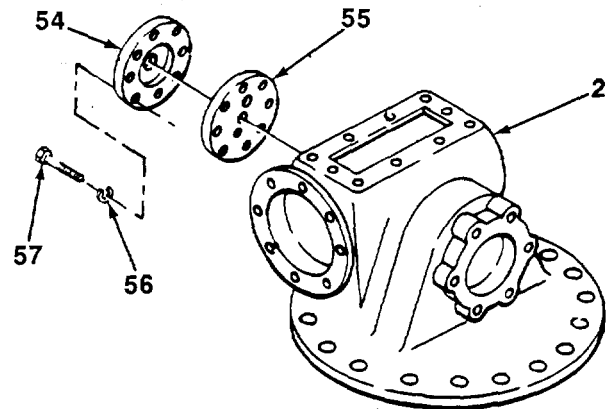

TA703990

9-5. REAR-REAR DIFFERENTIAL MAINTENANCE (Con't).

2. Install new gasket (3) and differential carrier (2) to rear-rear axle housing (5) with 18 new lockwashers (6) and nuts (1).

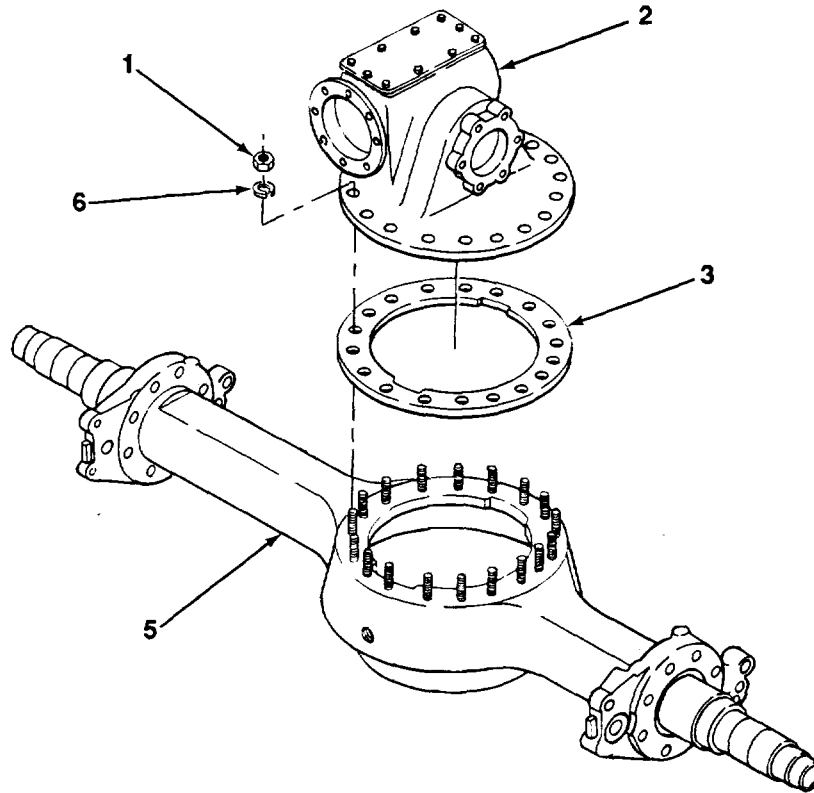
**FOLLOW-ON TASKS:**

- Install rear-rear axle shafts (see paragraph 8-4).
- Install rear-rear axle (see paragraph 8-4).
- Fill rear-rear differential (see LO 5-3805-254-12).

TA703991

CHAPTER 10
BRAKE SYSTEM MAINTENANCE

Paragraph Number	Paragraph Title	Page Number
10-1	Front Brake Spider and Dust Shield Maintenance	10-1
10-2	Air Compressor Governor Replacement	10-7
10-3	Air Compressor Repair	10-8

10-1. FRONT BRAKE SPIDER AND DUST SHIELD MAINTENANCE.

This Task Covers:

- | | |
|----------------------------|-----------------|
| a. Removal | d. Assembly |
| b. Disassembly | e. Installation |
| c. Cleaning and Inspection | |

Initial Setup:

Equipment Conditions:

- Front brakeshoes removed (see TM 5-3805-254-20).
- Front airbrake chambers removed (see TM 5-3805-254-20).

Tools/Test Equipment:

- General mechanic's tool kit
- Field automotive shop set
- Fourteen lockwashers

Materials/Parts:

- Grease (Item 10, Appendix B)
- Dry cleaning solvent (Item 23, Appendix B)
- Masking tape (Item 29, Appendix B)
- Two cotter pins
- Four gaskets
- Six seals

General Safety Instructions:

- Dry cleaning solvent is flammable and must not be used near open flame. Use only in a well-ventilated area.

10-1. FRONT BRAKE SPIDER AND DUST SHIELD MAINTENANCE (Con't).

a. REMOVAL

NOTE

Perform the following steps for front brake spider and dust shield at left or right side of vehicle.

- 1. Remove two wedge (10) assemblies from rear of brake spider (2).
- 2. Mark top of brake spider (2) for installation.
- 3. Remove eight nuts (8), lockwashers (7), bolts (1), and brake spider (2) from steering knuckle (9). Discard lockwashers.
- 4. Remove four bolts (6), lockwashers (5), and dust shield (3) from brake spider (2). Discard lockwashers.
- 5. remove four cap plugs (4) from dust shield (3).

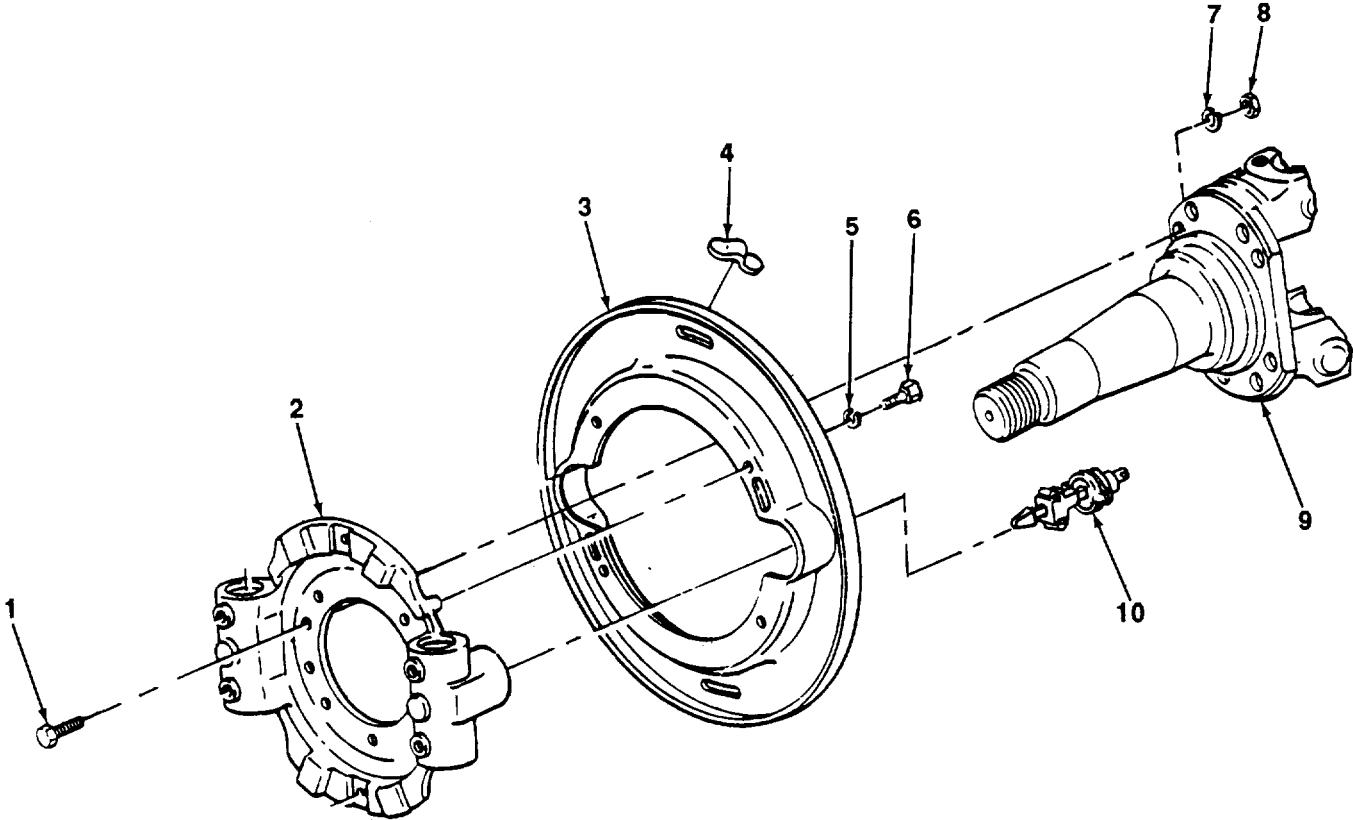

TA703992

10-1. FRONT BRAKE SPIDER AND DUST SHIELD MAINTENANCE (Con't).

b. DISASSEMBLY

WARNING

Wedge assembly is under spring pressure. Use care when disassembling to avoid injury.

NOTE

Perform steps 1 through 3 to disassemble wedge assembly.

1. While compressing spring (14) and retainer washer (13), remove cotter pin (12). Discard cotter pin.
2. Relax spring (14) and remove retainer washer (13), spring, seal (15), return washer (16), and cage (17) from wedge (10) assembly. Discard seal.
3. Remove two wedge rollers (11 and 18) from cage (17).

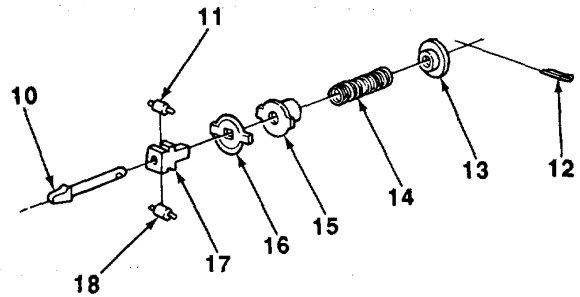

NOTE

Perform steps 4 through 8 to disassemble brake spider.

4. Remove two nuts (23), lockwashers (24), bolts (25), and clips (26) from brake spider (2). Discard lockwashers.

NOTE

- Perform the following steps to disassemble each of two adjusting plunger assemblies on brake spider.
- Note position of adjusting plunger assemblies for assembly.

5. Remove plunger (31), gasket (32), spring (33), and guide (34) from brake spider (2). Discard gasket.
6. Pry seal (20) loose from brake spider (2) and remove seal, adjusting plunger (22), adjusting spacer (21), and ring screw (19). Discard seal.
7. Remove guide bolt (30) and gasket (29) from brake spider (2). Discard gasket.
8. Pry seal (27) loose from brake spider (2) and remove seal and anchor plunger (28). Discard seal.

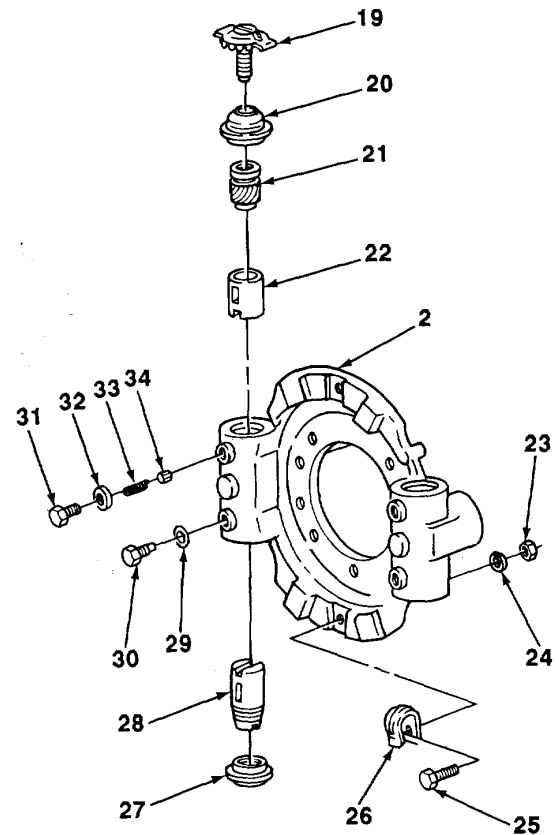

TA703993

10-1. FRONT BRAKE SPIDER AND DUST SHIELD MAINTENANCE (Con't).

c. CLEANING AND INSPECTION

WARNING

Dry cleaning solvent, P-D-680, is toxic and flammable. Always wear protective goggles and gloves, and use only in a well-ventilated area. Avoid contact with skin, eyes, and clothes, and DO NOT breathe vapors. DO NOT use near open flame or excessive heat. The solvent's flash point is 100°F-138°F (38°C-59°C). If you become dizzy while using cleaning solvent, immediately get fresh air and medical help. If solvent contacts eyes, immediately wash your eyes and get medical aid.

1. Clean metal parts with dry cleaning solvent.
2. Inspect metal parts for cracks, breaks, wear, corrosion, and other damage. Replace if damaged.
3. Inspect springs for breaks and distortion. Replace if damaged.

d. ASSEMBLY

CAUTION

Do not install seals into brake spider before installing plunger assembly parts. Seals will not fully seat into grooves of parts and sealing capacity will be lost.

NOTE

Perform the following steps to assemble each of two adjusting plunger assemblies on brake spider.

1. Apply masking tape over slot in end of anchor plunger (28).
2. Apply thin coat of grease to lips of new seal (27).
3. Install seal (27) to anchor plunger (28). Ensure that both seal lips are fully seated in grooves of anchor plunger. Remove masking tape.
4. Apply thin coat of grease to two bores of brake spider (2).

NOTE

1^{3/4} in. socket may be used as tool when pressing in seal and anchor plunger.

5. Press seal (27) and anchor plunger (28) into brake spider (2) with slot of anchor plunger facing threaded hole in brake spider. Ensure that anchor plunger and seal are fully seated.
6. Install new gasket (29) and guide bolt (30).

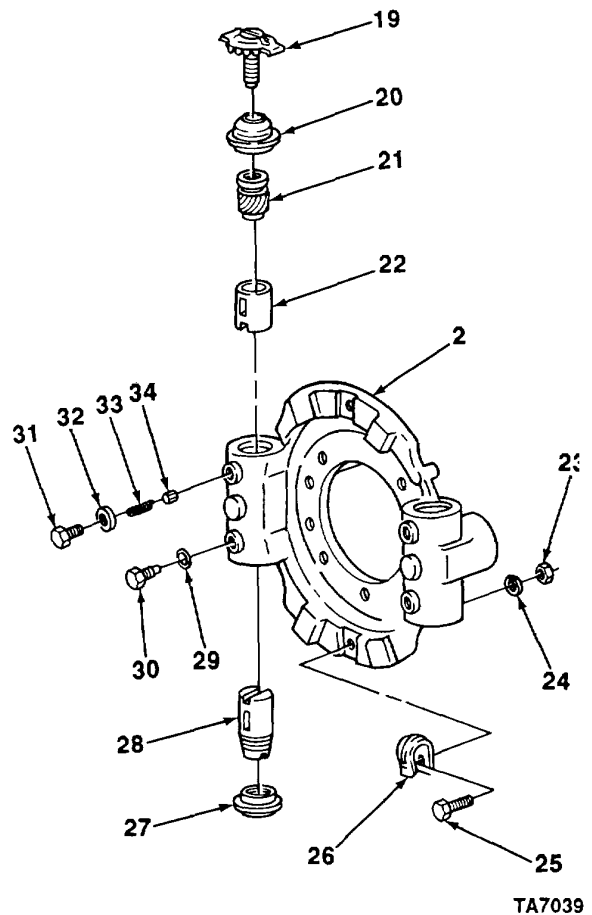

TA7039

10-1. FRONT BRAKE SPIDER AND DUST SHIELD MAINTENANCE (Con't).

7. Apply a thin coat of grease to surface of adjusting plunger (22) and adjusting spacer (21).
8. Install adjusting plunger (22) into brake spider (2) with slot of adjusting plunger facing threaded hole in brake spider.
9. Install adjusting spacer (21) into adjusting plunger (22).

NOTE

Ensure that guide is installed teeth first, with chamfer of guide facing location of closest brakeshoe.

10. Apply thin coat of grease to surface of guide (34) and install guide, spring (33), new gasket (32), and plunger (31) on brake spider (2). Do not fully tighten plunger.

NOTE

Perform steps 11 through 13 to check for proper meshing of adjusting plunger and guide teeth.

11. Apply a thin coat of grease to threads of ring screw (19) and install ring screw into adjusting spacer (21) until seated.
12. Continue rotating ring screw (19). There should be a clicking sound.
13. Rotate ring screw (19) in opposite direction about three turns. If there is no clicking sound, meshing of teeth is correct. Remove ring screw. If there is a clinking sound, meshing of teeth is incorrect. Repeat steps 12 and 13 until meshing is correct.
14. Torque plunger (31) to 15-20 lb.-ft. (20-27 N.m).
15. Apply thin coat of grease to lips of new seal (20).
16. Install seal (20) to adjusting plunger (22). Ensure that seal lip is fully seated in groove of adjusting spacer (21).

NOTE

1^{3/4} in. socket may be used as tool when pressing seal into brake spider.

17. Press seal (20) into brake spider (2).
18. Install ring screw (19) through seal (20) into adjusting spacer (21). Rotate ring screw until ring screw almost touches seal.
19. Install two clips (26) to brake spider (2) with two bolts (25), new lockwashers (24), and nuts (23). Perform steps 20 through 23 to assemble wedge assembly.

NOTE

Perform steps 20 through 23 to assemble wedge assembly.

20. Apply thin coat of grease to wedge (10) assemble and wedge rollers (11 and 18).
21. Install two wedge rollers (11 and 18) on cage (17)
22. Install cage (17), return washer (16), new seal (15) spring (14), and retainer washer (13) to wedge (10) assembly.
23. While compressing spring (14) and retainer washer (13), install new cotter pin (12).

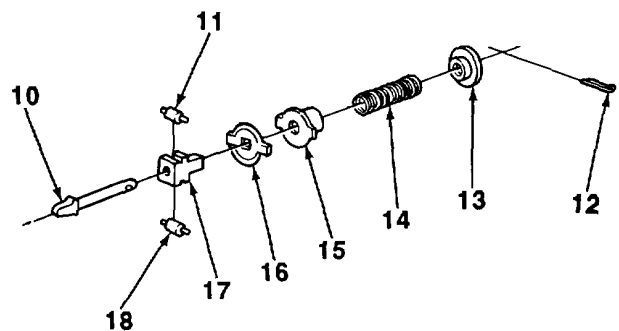

TA703995

10-1. FRONT BRAKE SPIDER AND DUST SHIELD MAINTENANCE (Con't) .**e. INSTALLATION I**

1. Install four cap plugs (4) to dust shield (3).
2. Install dust shield (3) to brake spider (2) with four new lockwashers (5) and bolts (6).
3. Install brake spider (2) and dust shield (3) to steering knuckle (9) with eight bolts (1), new lockwashers (7), and nuts (8).
4. Position two wedge (10) assemblies into rear of brake spider (2).

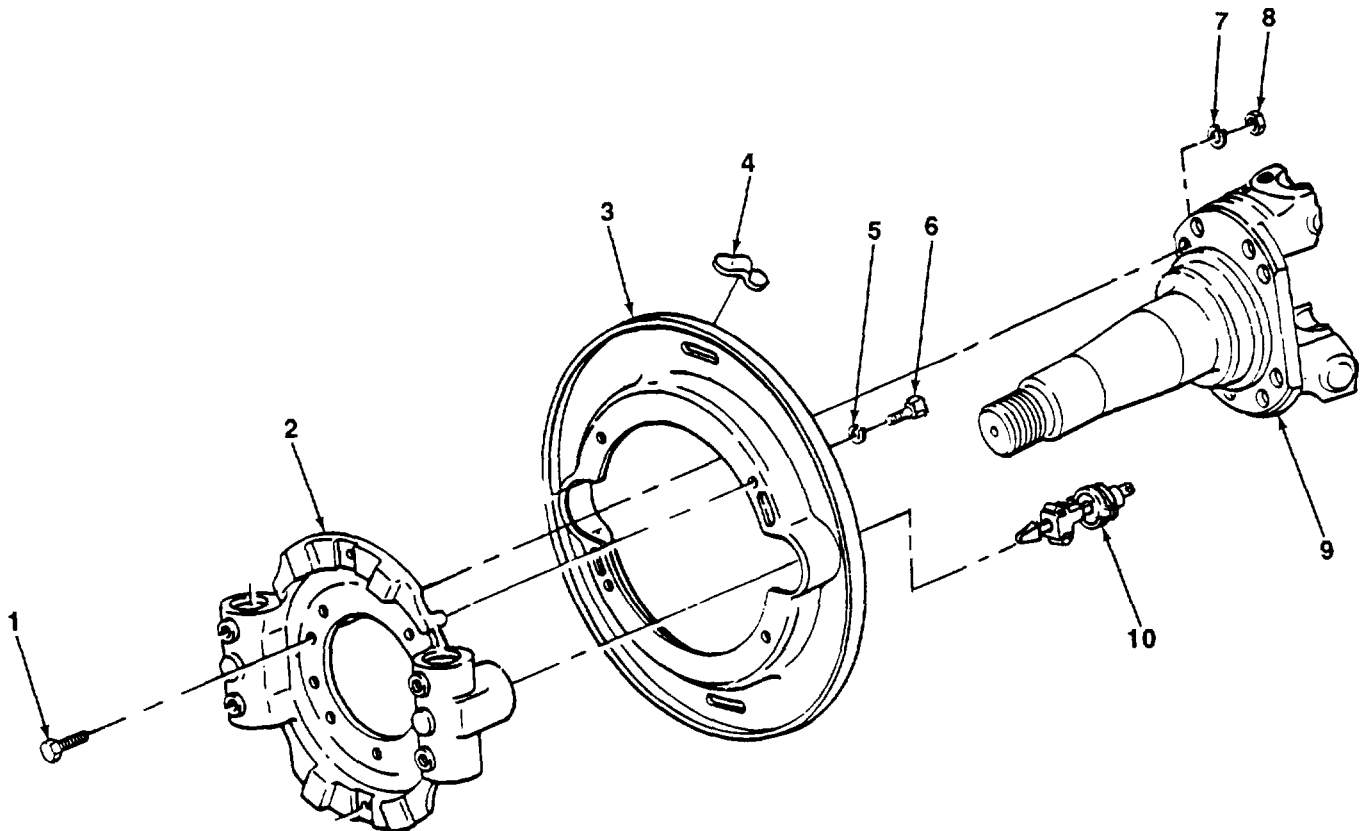
**FOLLOW-ON TASKS:**

- Install front airbrake chambers (TM 5-3805-254-20).
- Install front brakeshoes (TM 5-3805-254-20).

TA703996

10-2. AIR COMPRESSOR GOVERNOR REPLACEMENT.

This Task Covers: Replacement

Initial Setup:

Equipment Conditions:

- Air compressor governor to air dryer lines disconnected and tagged, and fittings removed from air compressor governor (see TM 5-3805-254-20).
- Air compressor governor to wet air reservoir lines disconnected and tagged, and fittings removed from air compressor governor (see TM 5-3805-254-20).

Materials/Parts:

- One gasket
- Two lockwashers

Tools/Test Equipment:

- General mechanic's tool kit

REPLACEMENT

1. Remove two screws (2), lockwashers (3), air compressor go(1), and casket (4) from air compressor (5) Discard gasket and lockwashers.
2. Install new gasket (4) and air compressor governor (1) on air compressor (5) with two new lockwashers (3) and screws (2).

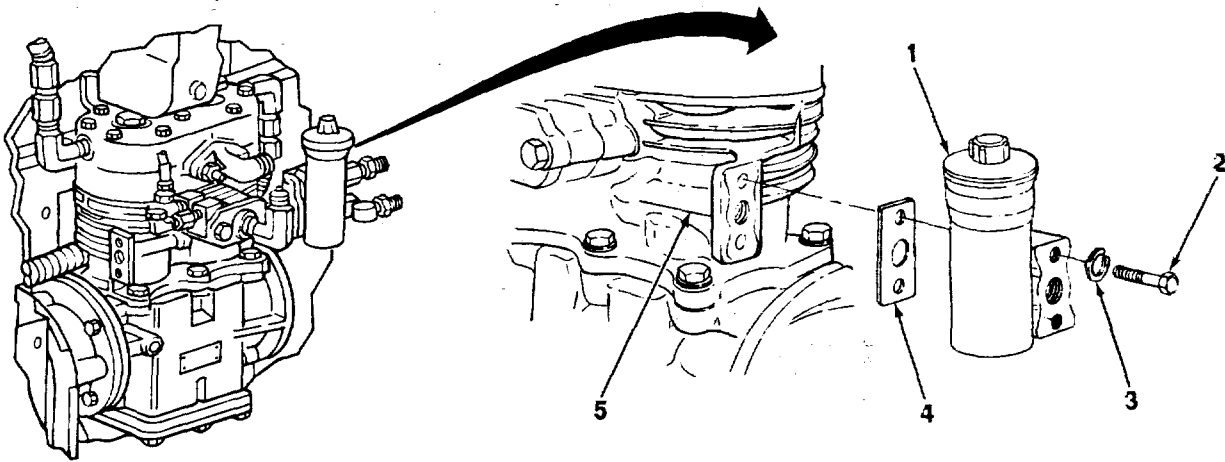
**FOLLOW-ON TASKS:**

- Install fittings and connect air compressor governor to air dryer lines to air compressor governor (see TM 5-3805-254-20).
- Install fittings and connect air compressor governor to wet air reservoir lines to air compressor governor (see TM 5-3805-254-20).

TA703997

10-3. AIR COMPRESSOR REPAIR.

This Task Covers:

- | | |
|--|---|
| <ul style="list-style-type: none"> a. Disassembly b. Cleaning and Inspection | <ul style="list-style-type: none"> c. Assembly |
|--|---|
-

Initial Setup:

Equipment Conditions:

- Air compressor hoses and fittings disconnected (see TM 5-3805-254-20).
- Alcohol evaporator and bracket removed (see TM 5 3805-254-20).
- Steering oil reservoir and bracket removed (see TM 5-3805-254-20).
- Primary fuel filter and bracket removed (see TM 5 3805-254-20).
- Accelerator control rod disconnected from fuel pum: (see TM 5-3805-254-20).
- Air compressor and fuel pump removed (see TM 5 2815-241-34&P).
- Fuel pump separated from air compressor (see TM 5 2815-241-34&P).
- Air compressor governor removed (see para graph 10-2).

a. DISASSEMBLY

1. Remove two bolts (9), lockwashers (8), flange (7), gasket (6), adapter (5), gasket (4), adapter (3), and gasket (2) from block (1). Discard lockwashers and gaskets.

Materials/Parts:

- Dry cleaning solvent (item 23, Appendix B)
- Marker tags (Item 25, Appendix B)
- One snapping
- Four keywashers
- Seven gaskets
- Ten piston rings
- Sixteen lockwashers

Tools/Test Equipment:

- General mechanic's tool kit
- Field automotive shop set

General Safety Instructions:

- Dry cleaning solvent is flammable and must not be used near open flame. Use only in a well-ventilated area.

10-3. AIR COMPRESSOR REPAIR (Con't).

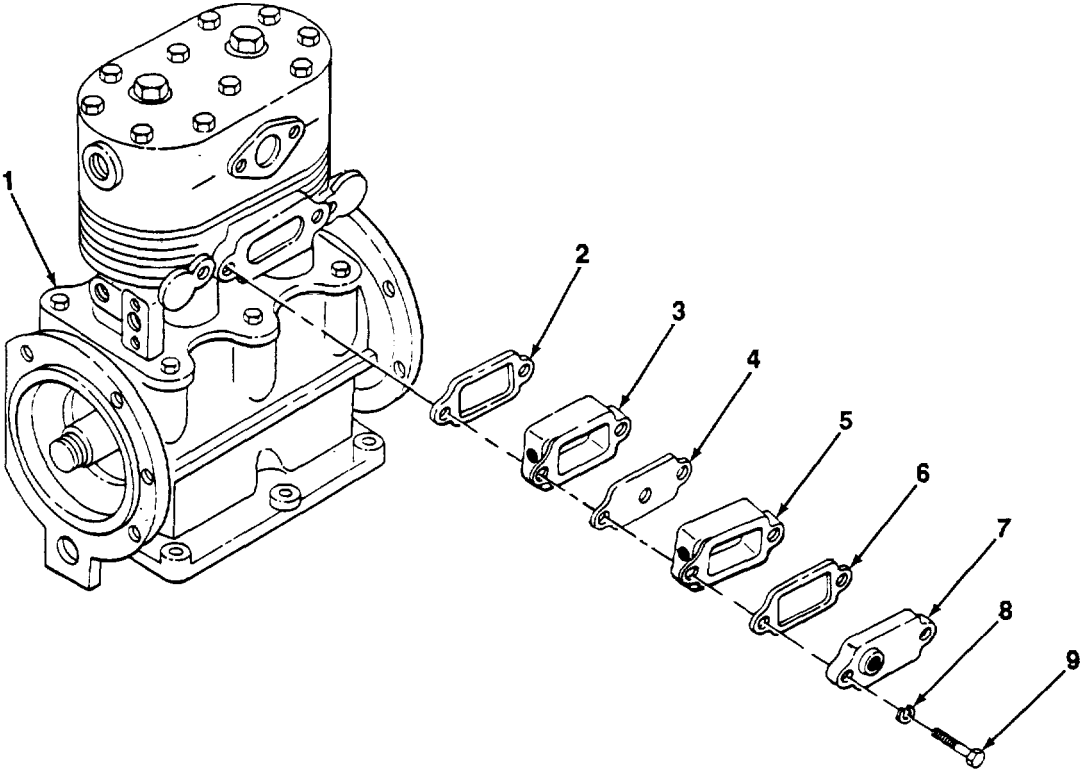

- 2. Remove two nuts (13), lockwashers (14), fitting (12), and gasket (11) from head (10). Discard lockwashers and gasket.
- 3. If damaged, remove and discard studs (15).

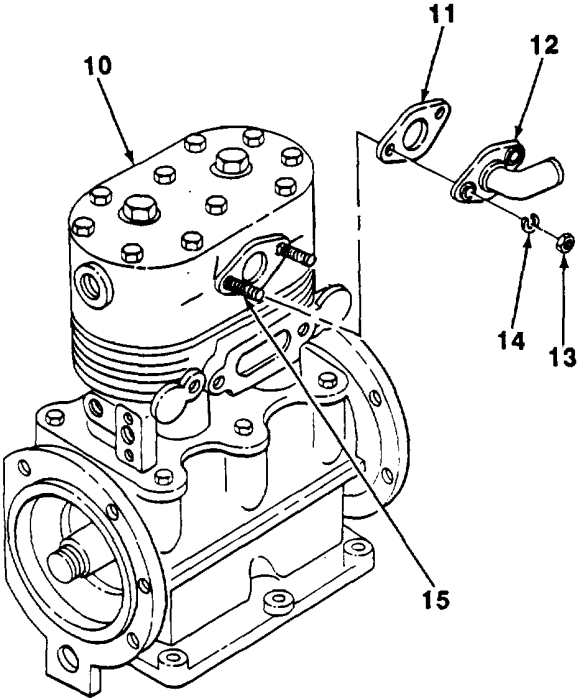

TA703998

10-3. AIR COMPRESSOR REPAIR (Con t).

NOTE

Scribe mark on front of head and block to aid in assembly

4. Remove ten bolts (16), head (10), two springs (17), and gasket (18) from block (1). Discard gasket.
5. Remove six bolts (21), lockwashers (20), cover (22), and gasket (23) from crankcase (19). Discard lockwashers and gasket.

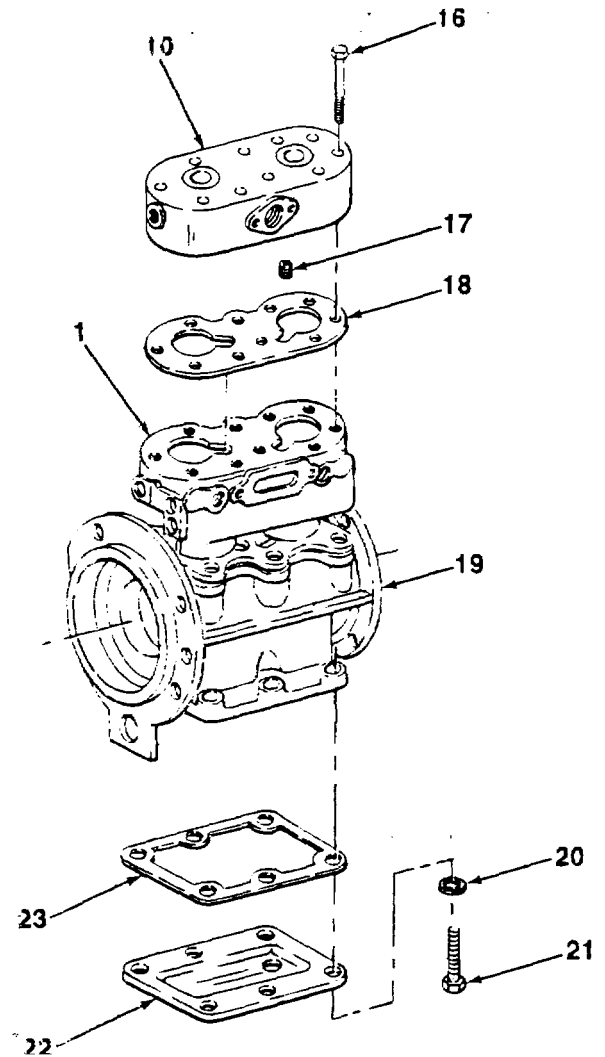

TA703999

10-3. AIR COMPRESSOR REPAIR (Con't).

NOTE

Tag valves and valve seats for assembly. Valves and valve seats must be assembled in same position on head.

- 6. Remove two caps (24), springs (25), and valve seats (26 and 27) from head (10).
- 7. Remove two seats (30), inserts (31), valve guides (29), and disks (28) from head (10).

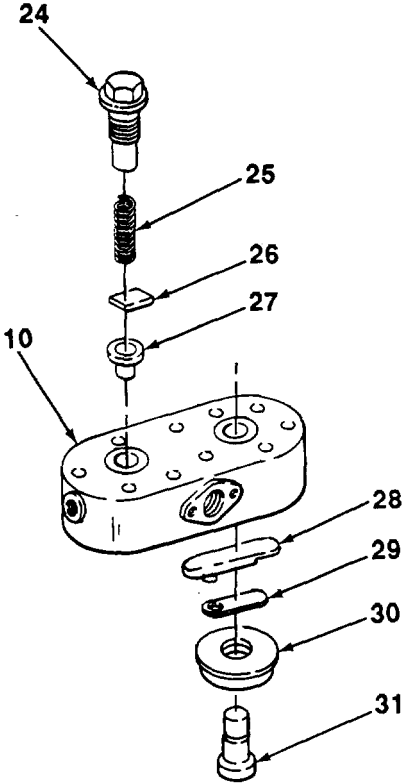

- 8. Compress spring (33) and remove two pins (35) and valves (36) from block (1).
- 9. Remove bracket (34), two rings (37), grommets (38), and spring (33) from block (1).
- 10. If damaged, remove and discard spring seat (32).

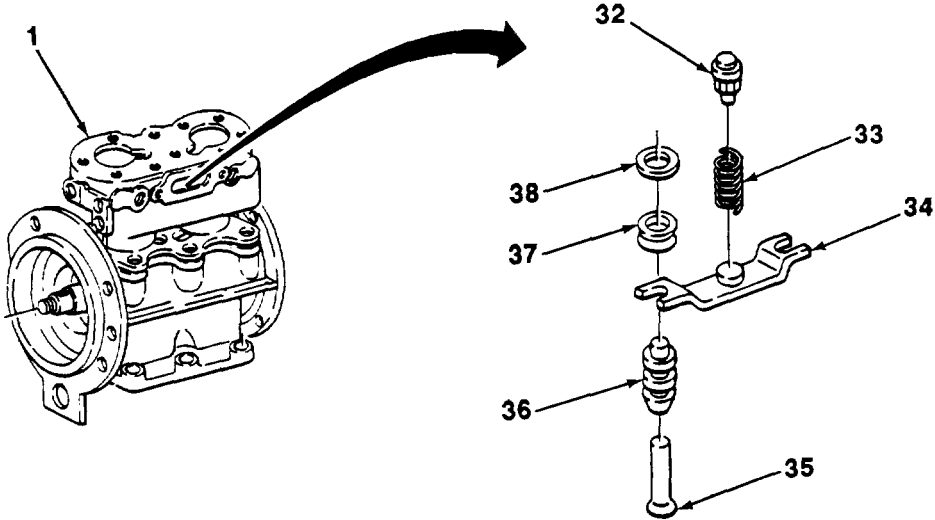

10-3. AIR COMPRESSOR REPAIR (Con't).

NOTE

Perform steps 11 through 17 for each of two pistons.

- 11. Bend tabs of two keywashers (43) and remove bolts (44), keywashers, and connecting rod half (45) from connecting rod half (40). Discard keywashers.

NOTE

Note position of piston on block for assembly.

Piston must be Installed In same hole.

- 12. Tap piston (39) assembly from top of block (1).

NOTE

If replacing one bearing, other bearing must also be replaced.

- 13. If scored, corroded, or damaged, remove bearings (41 and 42) from connecting rod halves (40 and 45) and discard.
- 14. Remove wire (47) from piston (39) and pin (49).
- 15. Remove pin (49) and connecting rod half (40) from piston (39).
- 16. If damaged, remove bushing (48) from connecting rod half (40) and discard.

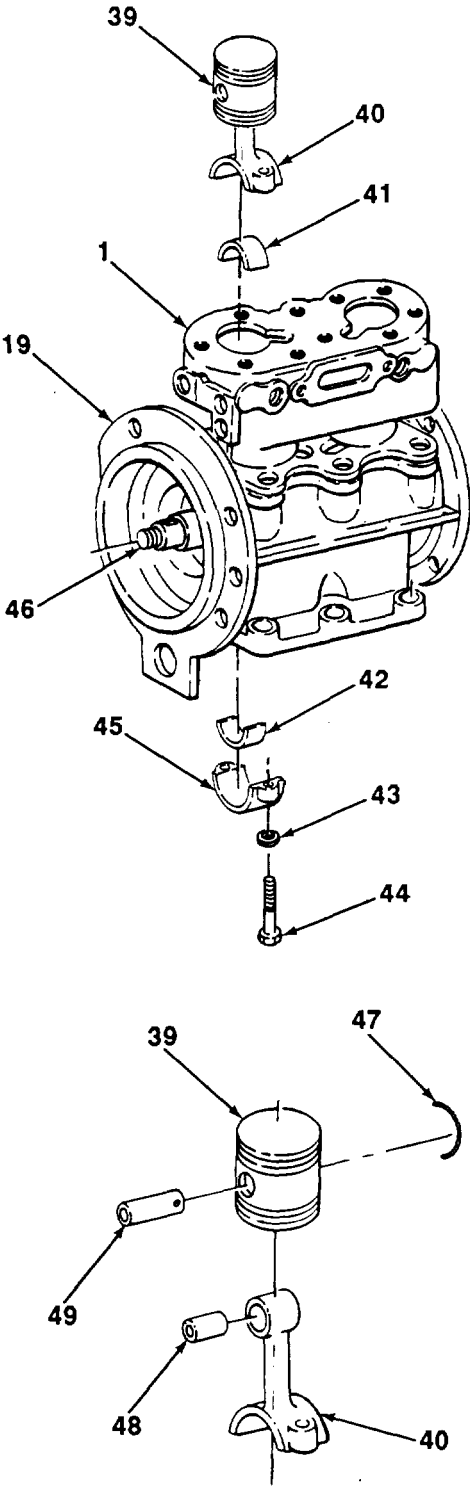

10-3. AIR COMPRESSOR REPAIR (Con't).

- 17. Remove and discard five piston rings (50) from piston (39).

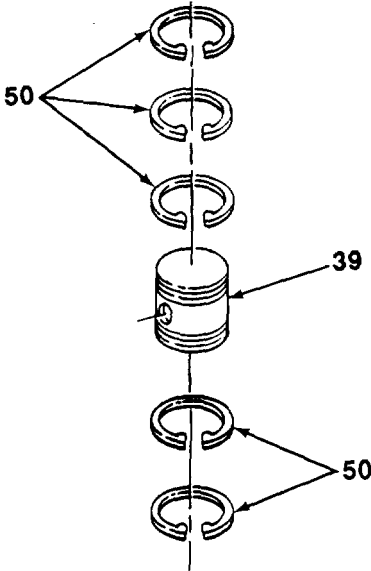

- 18. Remove nut (51), drive coupling (52), and woodruff key (53) from crankshaft (46).
- 19. Remove bolt (58), flatwasher (57), shaft coupling half (56), flatwasher (55), and woodruff key (54) from crankshaft (46).

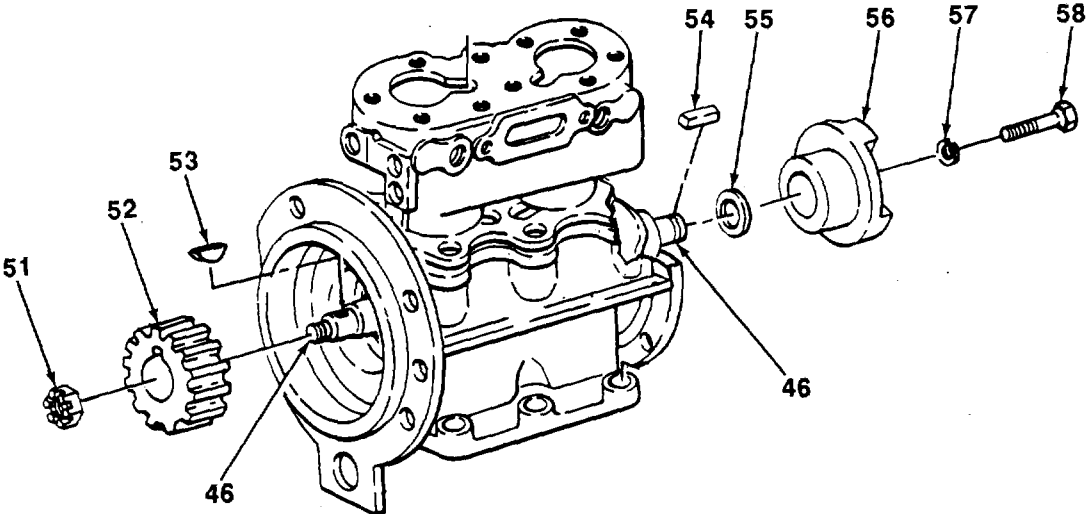

10-3. AIR COMPRESSOR REPAIR (Con't).

NOTE

Scribe mark on front of block and crankcase for assembly.

- 20. Remove six bolts (60), lockwashers (59), block (1), and gasket (61) from crankcase (19). Discard lockwashers and gasket.

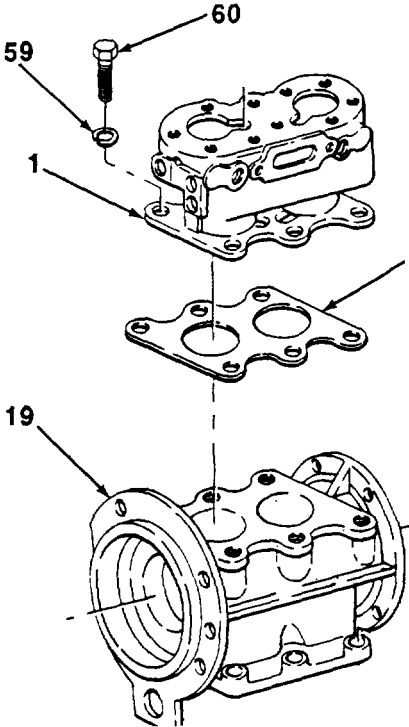

- 21. Remove snapping (64) from crankcase (19). Discard snapping.
- 22. Remove crankshaft (46), bearing (63), and bushing (62) from crankcase (19).

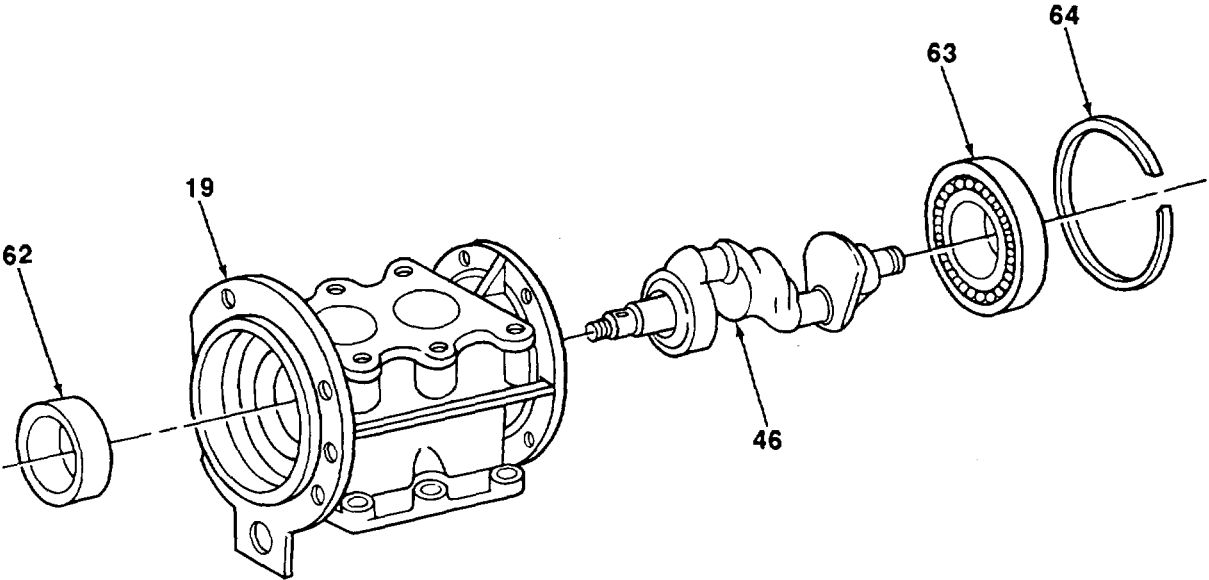

10-3. AIR COMPRESSOR REPAIR (Con't).**b. CLEANING AND INSPECTION****WARNING**

Dry cleaning solvent, P-D-68C, is toxic and flammable. Always wear protective goggles and gloves, and use only in a well-ventilated area. Avoid contact with skin, eye, and clothes, and DO NOT breathe vapors. DO NOT use near open flame or excessive heat. The solvent's flashpoint is 100°F -138°F (38°C-59° C). If you become dizzy while using cleaning solvent, immediately get fresh air and medical help. If solvent contacts eyes, immediately wash your eyes and get medical aid.

1. Clean all parts with dry cleaning solvent.
2. Inspect parts for damage and corrosion. Replace damaged or corroded parts.

C ASSEMBLY

1. Install bushing (62) in crankcase (19).
2. Install crankshaft (46) in crankcase (19). Seat crankshaft in bushing (62).
3. Install bearing (63) and new snapping, (64) in crankcase (19).

NOTE

Ensure that scribe marks or block and crankcase are properly aligned.

4. Install new gasket (61) and block (1) on crankcase (19) with six new lockwashers (59) and bolts (60).
5. Install flatwasher (55) and woodruff key (54) on crankshaft (46).
6. Slide shaft coupling half (56) over woodruff 54 and install on crankshaft 46, with flatwasher (57) and bolt (58).
7. Install woodruff key (53) on crankshaft (46).

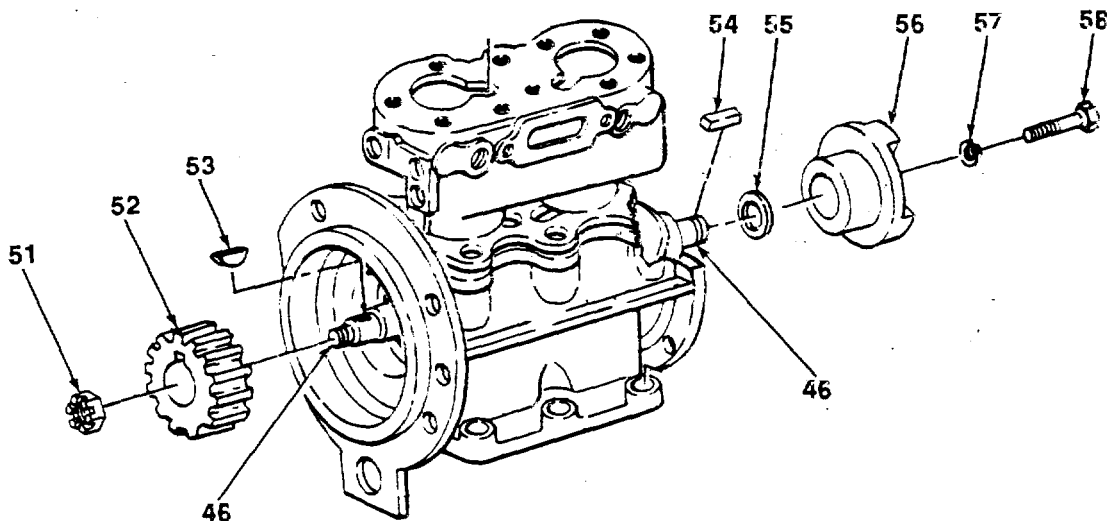

TA704004

10-3. AIR COMPRESSOR REPAIR (Con't).

NOTE

Perform steps 9 through 17 for each of two pistons.

- 9. Install five new piston rings (50) on piston (39). Ensure that splits in piston rings are all offset.
- 10. If removed, Install bushing (48) In connecting rod half (40).
- 11. Position connecting rod half (40) In piston (39) and Install pin (49).
- 12. Install wire (47) on pin (49) and piston (39).

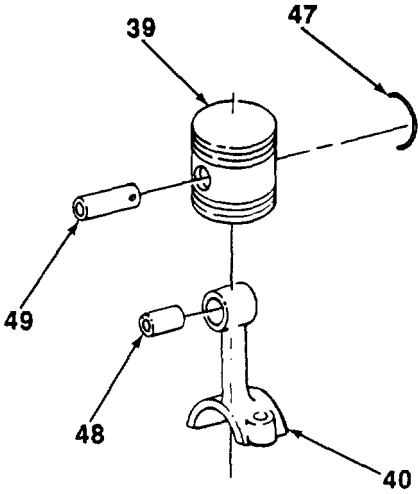
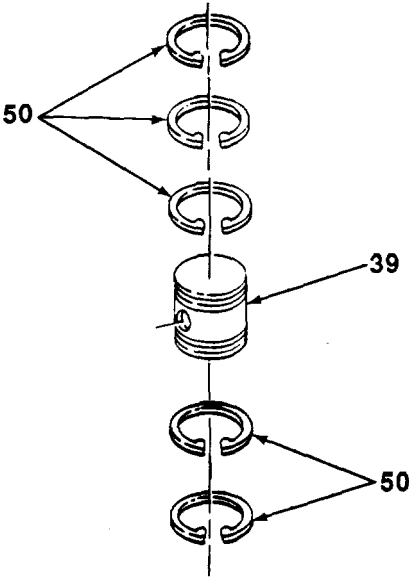

TA704005

10-3. AIR COMPRESSOR REPAIR (Con't).

13. If removed, install bearing (41) on connecting rod half (40).
14. Position piston (39) assembly in block (1).
15. Install piston (39) assembly in crankcase (19). Tap piston assembly until bearing (41) rests on crankshaft (46).
16. If removed, install bearing (42) on connecting rod half (45).
17. Install connecting rod half (45) on connecting rod half (40) with two new keywashers (43) and bolts (44). Do not tighten bolts.
18. Tighten bolts (44) evenly.
19. Rotate crankshaft (46) and check for free rotation.
20. Bend tabs of four keywashers (43) over bolts (44).

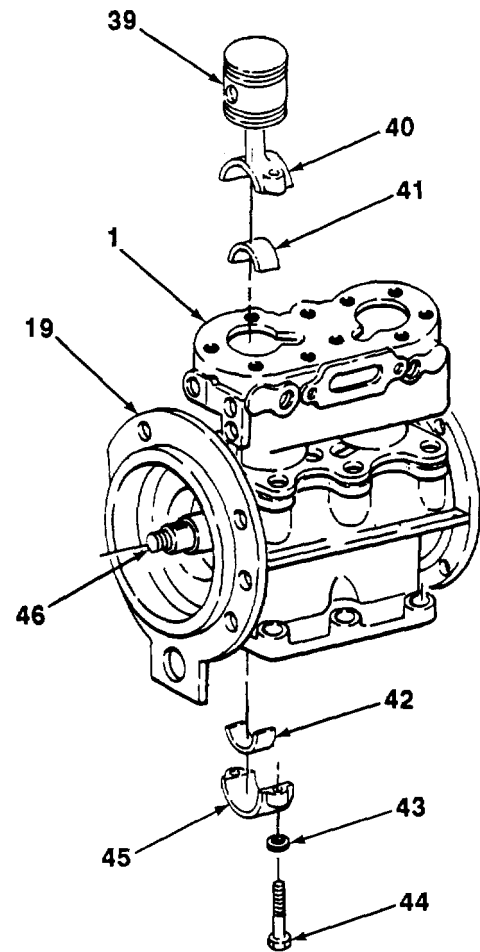

TA704006

10-3. AIR COMPRESSOR REPAIR (Con't).

- 21. If removed, install spring seat (32) on block (1).
- 22. Position, two valves (36, pins (35), grommets (38), and rings (37) on bracket (34).
- 23. Install spring (33) and bracket (34) in block (1).

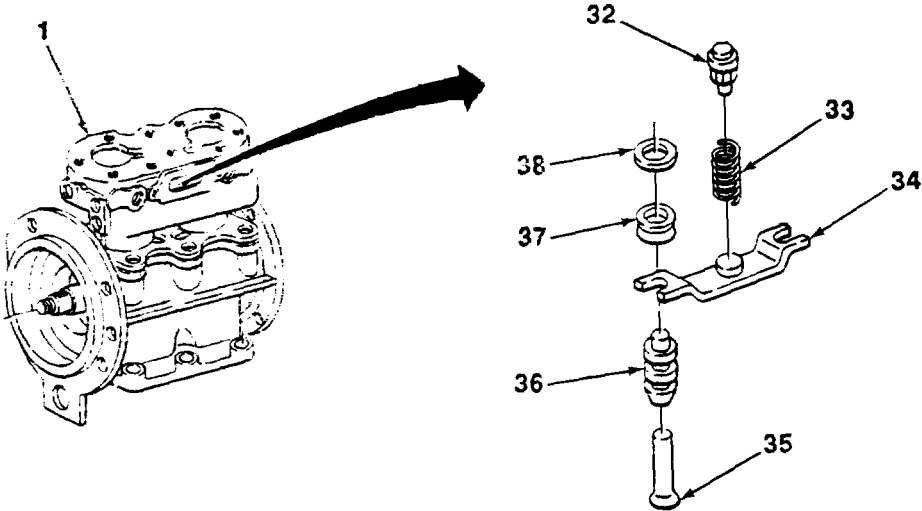

- 24. Install two disks (28), valve guides (29), inserts (31), and seats (33) in head (10).
- 25. Install two valve seats (27), valve seats (26), springs (25), and caps (24) on head (10).

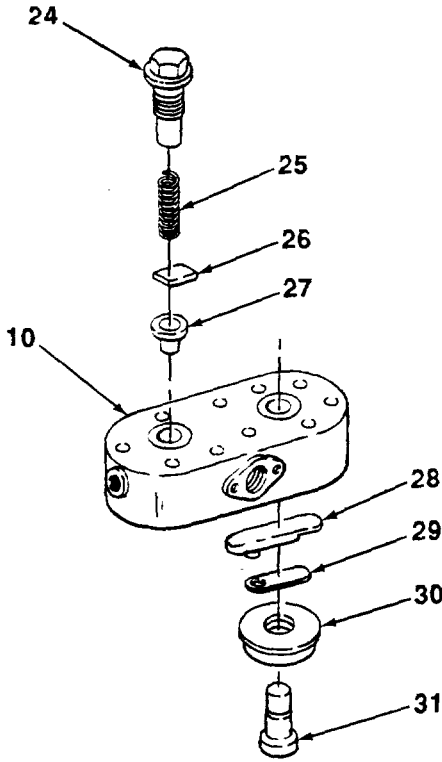

10-3. AIR COMPRESSOR REPAIR (Con't).

26. Install new gasket (23) and cover (22) on crankcase (19) with six new lockwashers (20) and bolts (21).

NOTE

Ensure that scribe marks on head and block are properly aligned.

27. Position two springs (17) on block (1) and install new gasket (18) and head (10) on block with ten bolts (16). Tighten bolts evenly in a crisscross

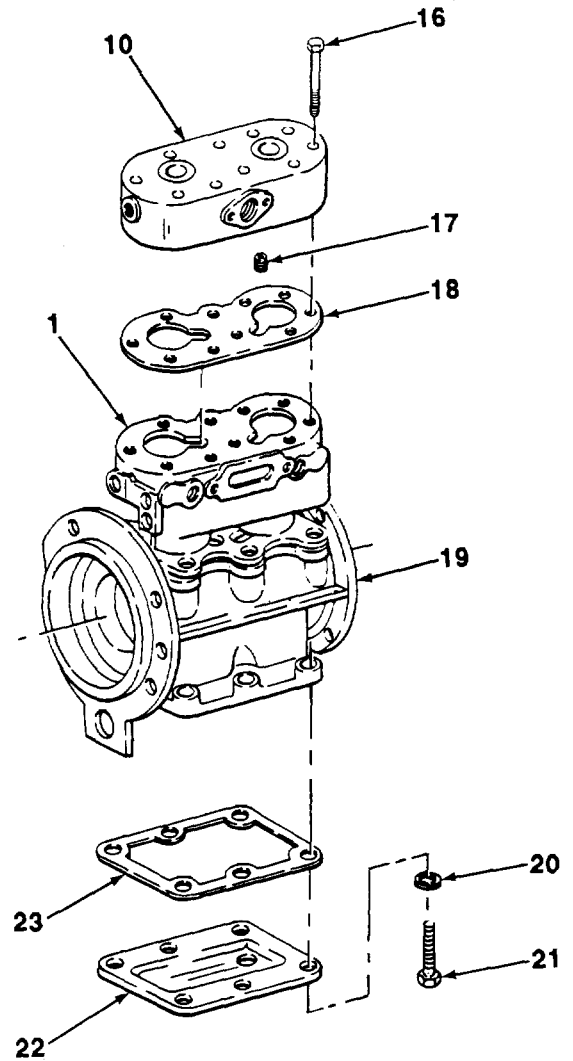

TA704008

10-3. AIR COMPRESSOR REPAIR (Con't).

- 28. If removed, install two studs (15) on head (10).
- 29. Install new gasket (11) and fitting (12) on two studs (15) with two new lockwashers (14) and nuts (13).

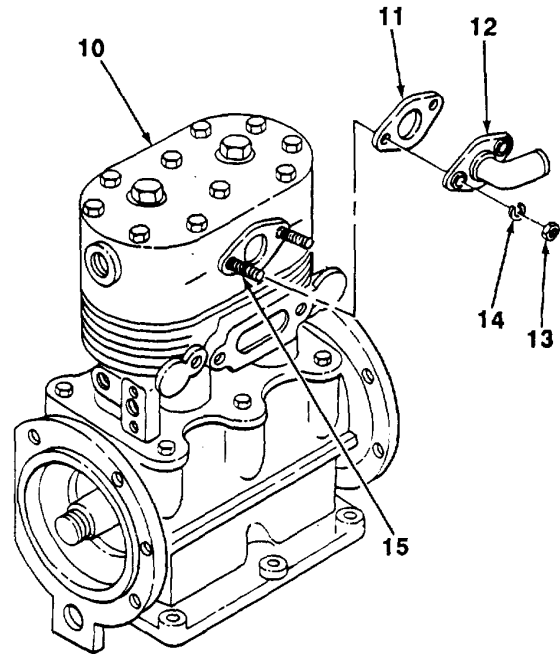

- 30. Install new gasket (2), adapter (3), new gasket (4), adapter (5), new gasket (6), and flange (7) on block (1) with two new lockwashers (8) and bolts (9).

TA704009

10-3. AIR COMPRESSOR REPAIR (Con't).

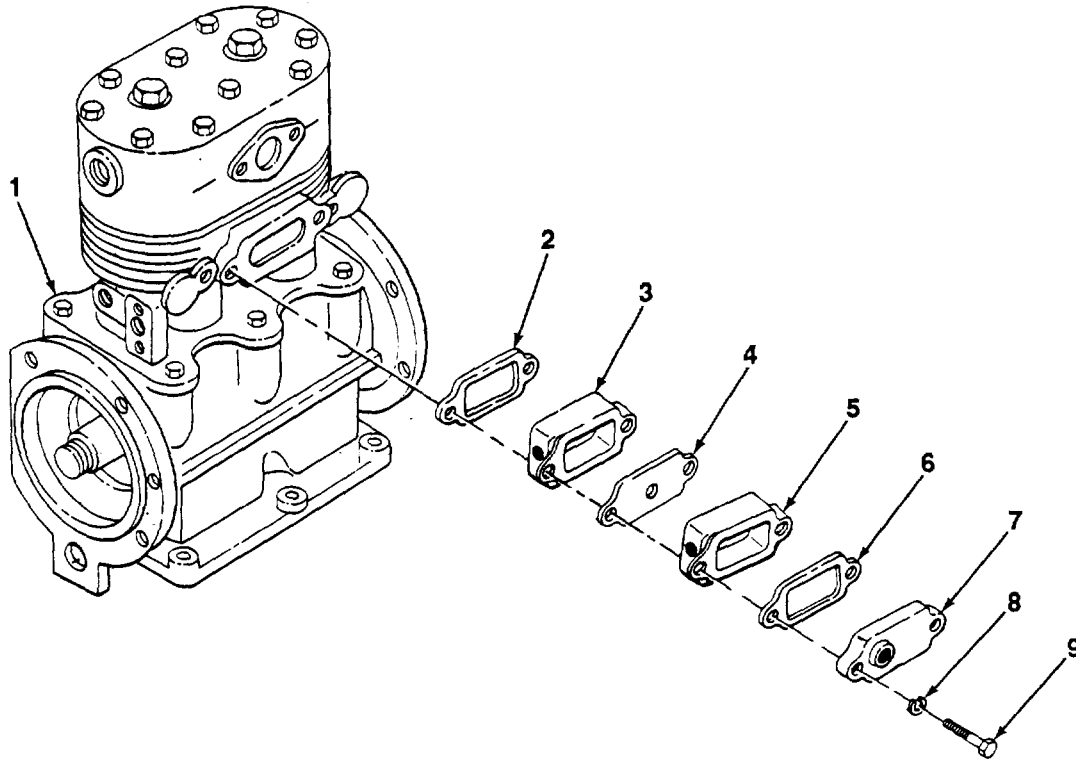
**FOLLOW-ON TASKS:**

- Install air compressor governor (see paragraph 10-2).
- Join fuel pump to air compressor (see TM 5-2815-241-34&P).
- Install air compressor and fuel pump (see TM 5-2815-241-34&P).
- Connect accelerator control rod to fuel pump (see TM 5-3805-254-20).
- Install primary fuel filter and bracket (see TM 5-3805-254-20).
- Install steering oil reservoir and bracket (see TM 5-3805-254-20).
- Install alcohol evaporator and bracket (see TM 5-3805-254-20).
- Connect air compressor hoses and fittings (see TM 5-3805-254-20).

TA704010

10-21/(10-22 Blank)

CHAPTER 11
WHEEL, TIRE, HUB, AND BRAKEDRUMS MAINTENANCE

Paragraph Number	Paragraph Title	Page Number
11-1	Brakedrum Repair	11-1
11-2	Tire Repair	11-4

11-1. BRAKEDRUM REPAIR.

This Task Covers:

- a. Cleaning and Inspection
- b. Repair

Initial Setup:

Equipment Conditions:

- Brakedrum removed (see TM 53805-254-20).

Tools/Test Equipment:

- General mechanic's too) kit
- Field automotive shop set
- Brakedrum lathe

Materials/Parts:

- Rags (Item 17, Appendix B)
- Dry cleaning solvent (Item 23, Appendix B)

General Safety Instructions:

- Dry cleaning solvent is flammable and must not be used near open flame. Use only in a well-ventilated area.
- DO NOT use a dry brush or compressed air to clean brake assembly or brake components.

11-1. BRAKEDRUM REPAIR (Con't).

a. CLEANING AND INSPECTION**WARNING**

- DO NOT handle brake assembly components unless area has been properly cleaned. There may be asbestos dust on these components which can be dangerous if you touch it or breathe it. Wear an approved filter mask and gloves. Never use compressed air or a dry brush to clean brake assembly components. Dust may be removed using an industrial-type vacuum cleaner. Clean dust or mud away from brake components with water and a wet, soft brush or cloth. Failure to follow this warning may result in serious illness or death to personnel.
- Dry cleaning solvent, P-D-680, is toxic and flammable. Always wear protective goggles and gloves, and use only in a well-ventilated area. Avoid contact with skin, eyes, and clothes, and DO NOT breathe vapors. DO NOT use near open flame or excessive heat. The solvent's flash point is 100°F-138°F (38°C-59°C). If you become dizzy while using cleaning solvent, immediately get fresh air and medical help. If solvent contacts eyes, immediately wash your eyes and get medical aid.

1. Use dry cleaning solvent to remove grease and oil from brakedrum (1). Dry thoroughly.
2. Inspect stud holes (2) for cracks. Discard brakedrum (1) if cracks are present.
3. Inspect braking surface (6) for cracks (3) and heat checking (4). If damaged, reface braking surface (see subparagraph b.)
4. Inspect braking surface (6) for scoring (5) and bellmouth. Measure depth of scoring or bellmouth using dial indicator. If depth of scoring or bellmouth exceeds 0.005 in. (0.127 mm), reface braking surface (see subparagraph b).

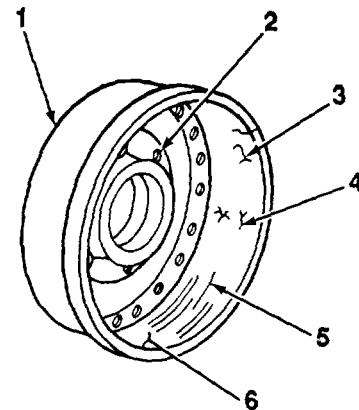

TA704011

11-1. BRAKEDRUM REPAIR (Con't).

5. Inspect braking surface (6) for out-of-round at 450 intervals. If out-of-round exceeds 0.015 in. (0.381 mm), reface braking surface (see subparagraph b).

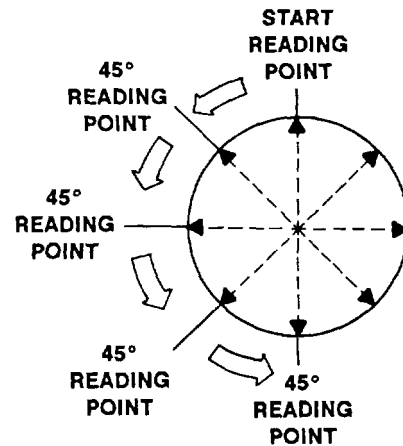
**WARNING**

DO NOT use a brakedrum that exceeds maximum wear specification. Failure to follow this warning may result in brake failure and serious injury or death.

NOTE

The maximum diameter a brakedrum can be worn or refaced to is stamped or cast into the outside surface of the brakedrum.

6. Measure inside diameter of brakedrum (1).
- (a) If diameter EXCEEDS maximum diameter marked on brakedrum (1), discard brakedrum.
 - (b) If diameter IS LESS THAN maximum diameter marked on brakedrum (1), reface braking surface (6) (see subparagraph b).

TA704012

11-1. BRAKEDRUM REPAIR (Con't).

b. REPAIR**WARNING**

DO NOT use a brakedrum that exceeds maximum wear specification. Failure to follow this warning may result in brake failure and serious injury or death.

1. Reface braking surface (6) of brakedrum (1) with brakedrum lathe. Remove a maximum of 0.01 in. (0.25 mm) per cut.
2. If inside diameter of brakedrum (1) now exceeds maximum diameter marked on brakedrum, discard brakedrum.

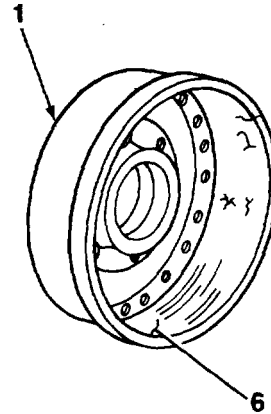
**FOLLOW-ON TASKS:**

- Install brakedrum (see TM 5-3805-254-20).

11-2. TIRE REPAIR.

Refer to TM 9-2610-200-14 for instructions on tire repair.

TA704013

CHAPTER 12
STEERING SYSTEM MAINTENANCE

Paragraph Number	Paragraph Title	Page Number
12-1	Left and Right Power Steering Gear Replacement	12-1
12-2	Left Power Steering Gear Repair	12-4
12-3	Right Power Steering Gear Repair	12-15
12-4	Bleed and Adjust Steering System	12-22
12-5	Steering Arms Replacement	12-25
12-6	Steering Column Maintenance	12-28
12-7	Steering Hydraulic Pump Maintenance	12-40
12-8	Steering Knuckle Maintenance	12-49
12-9	Steering Wheel Replacement	12-58
12-10	Tie-rod Maintenance	12-61
12-11	Drag Link Maintenance	12-66

12-1. LEFT AND RIGHT POWER STEERING GEAR REPLACEMENT.

This Task Covers:

- | | |
|------------|-----------------|
| a. Removal | b. Installation |
|------------|-----------------|

Initial Setup:

Equipment Conditions:

- Steering gear hoses and fittings removed (see TM 5-3805-254-20).
- Front fenders and front fender supports removed (see paragraph 15-24).
- Steering arm removed (see paragraph 12-5).
- Field automotive shop set

Materials/Parts:

- One cotter pin

Tools/Test Equipment:

- General mechanic's tool kit

Personnel Required: Two

12-1. LEFT AND RIGHT POWER STEERING GEAR REPLACEMENT (Con't).

a. REMOVAL

NOTE

- Left and right steering gears are removed in the same manner. Left steering gear removal is shown.
- Start with step 1 if removing left steering gear. Start with step 2 if removing right steering gear.

1. Remove cotter pin (1), slotted nut (2), and screw (3). Disconnect yoke (4) from actuating shaft (5). Discard cotter pin.
2. Remove four nuts (6), bolts (8), strap (9), and left or right steering gear (7) from frame (10).

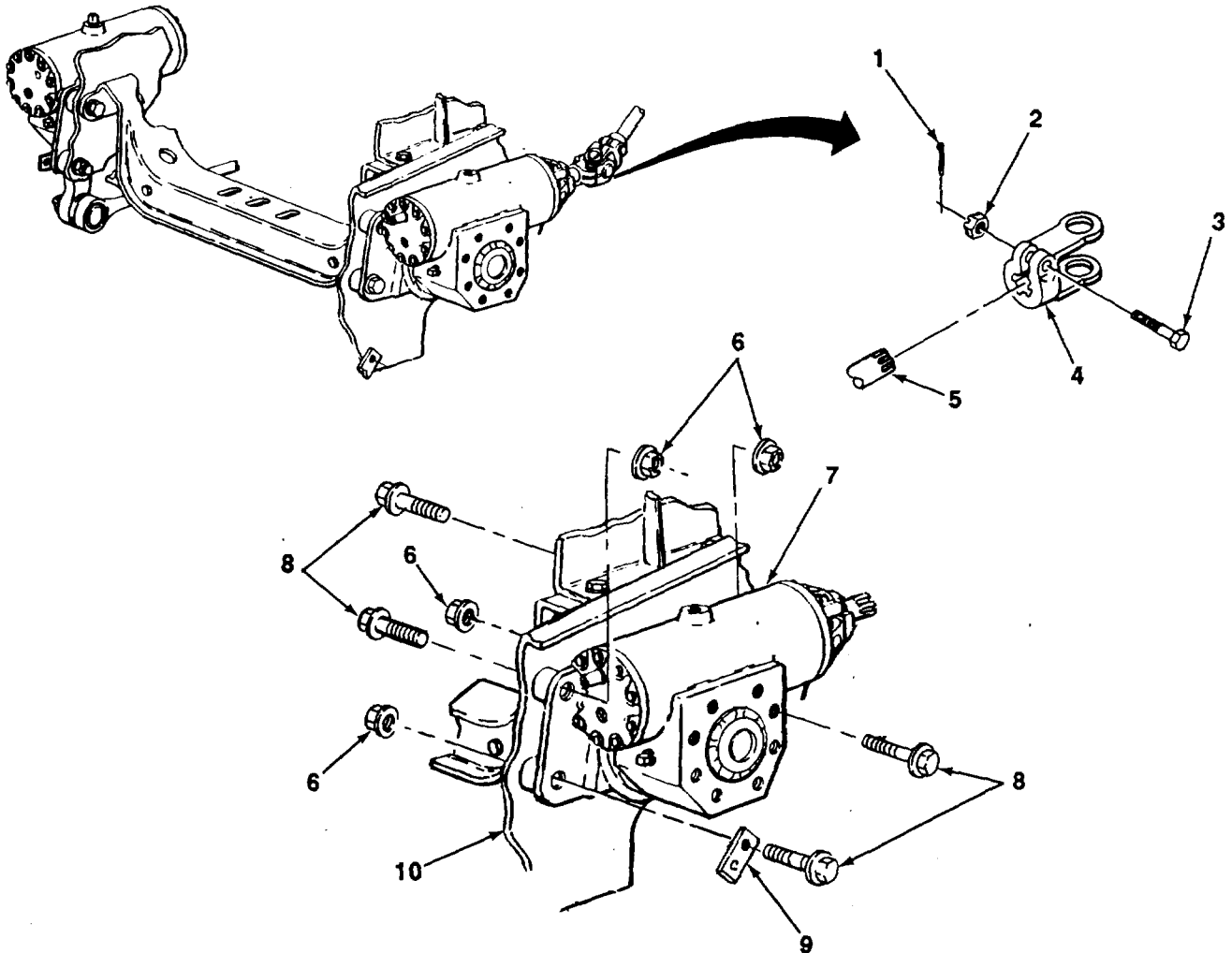

TA7040414

12-1. LEFT AND RIGHT POWER STEERING GEAR REPLACEMENT (Con't).

b. INSTALLATION

1. Install left or right steering gear (7) and strap (9) on frame (10) with four bolts (8) and nuts (6).
2. Install yoke (4) on actuating shaft (5).
3. Install screw (3), slotted nut (2), and new cotter pin (1) in yoke (4).

FOLLOW-ON TASKS:

- Install steering gear hoses and fittings (see TM 5-3805-254-20).
- Install front fenders and front fender supports (see paragraph 15-24).
- Install but do not connect steering arm (see paragraph 12-5).
- Bleed and adjust steering system (see paragraph 12-4).

12-2. LEFT POWER STEERING GEAR REPAIR.

This Task Covers:

- a. Disassembly
- b. Cleaning and Inspection
- c. Assembly

Initial Setup:

Equipment Conditions:

- Left power steering gear removed (see paragraph 12-1).
- One packing assembly

Tools/Test Equipment:

- General mechanic's tool kit
- Field automotive shop set
- Thirty lockwashers

General Safety Instructions:

- Dry cleaning solvent is flammable and must not be used near open flame. Use only in a well-ventilated area.

Materials/Parts:

- Lubricating oil (Item 13, Appendix B)
- Dry cleaning solvent (Item 23, Appendix B)

- Two gaskets
- Two seals
- Three performed packings

a. DISASSEMBLY

NOTE

Perform step 1 at each end of steering gear.

1. Loosen nut (1) and remove relief valve plunger (2), nut, and performed packing (3) from gear housing (4). Discard performed packing.

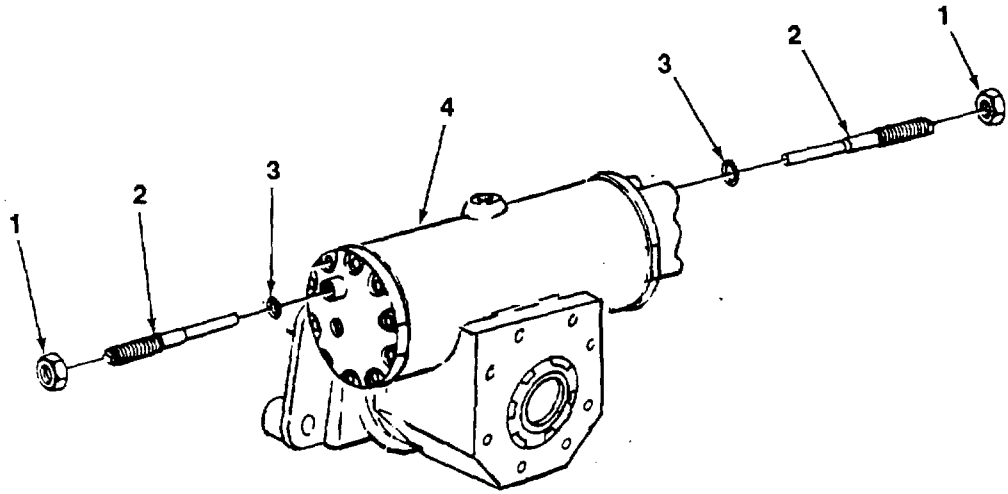

2. Remove eight screws (5), lockwashers (6), and housing cover (7) from gear housing (4). Discard lockwashers.
3. Remove performed packing (8) from housing cover (7). Discard performed packing.

TA704015

12-2. LEFT POWER STEERING GEAR REPAIR (Con't).

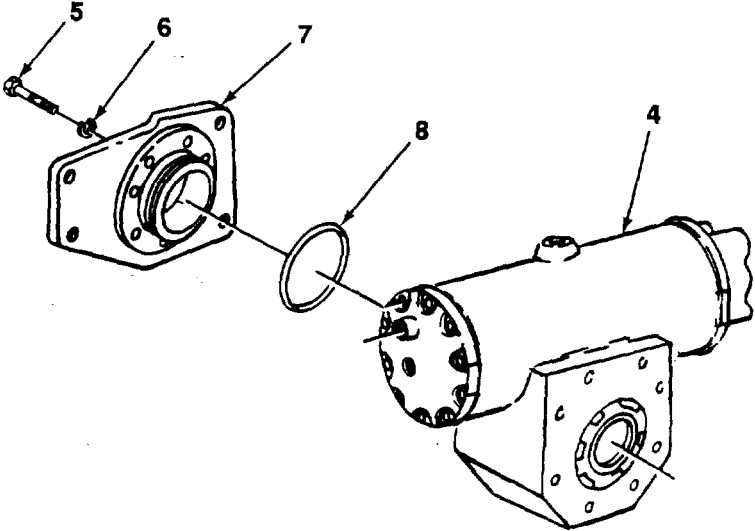

- 4. Remove two capscrews (9) and lockwashers (10) from gear retaining nut (11). Discard lockwashers.
- 5. Remove gear retaining nut (11) from output shaft (13) by rotating counterclockwise.

NOTE

Note position of alinement mark on center tooth of piston and gear for assembly.

- 6. Remove output shaft (13) and gear (12) from gear housing (4).

NOTE

Note position of alinement mark on output shaft and gear for assembly.

- 7. Press gear (12) from output shaft (13).

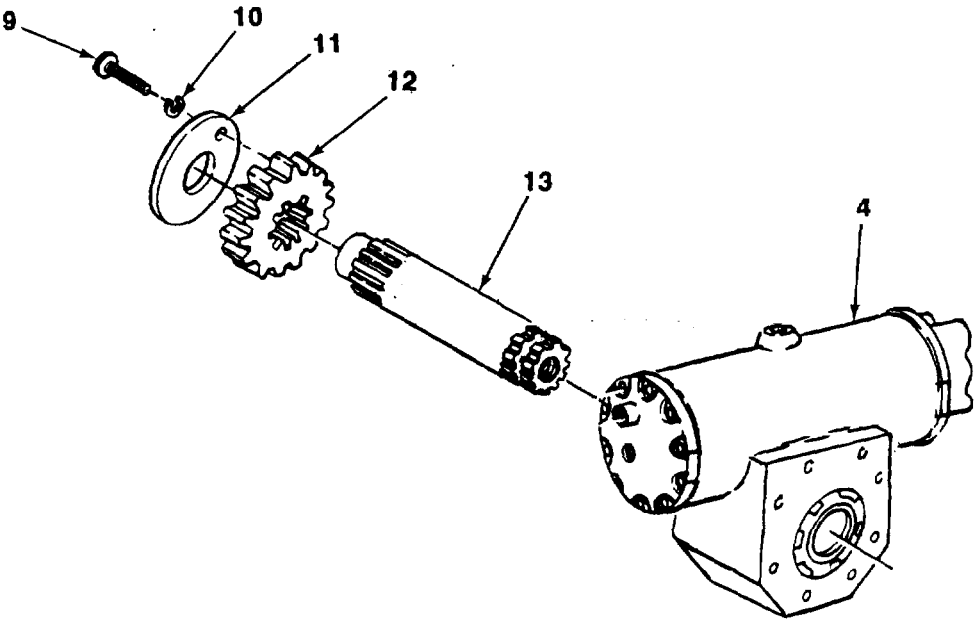

12-2. LEFT POWER STEERING GEAR REPAIR (Con't).

- 8. Make alinement marks on cylinder head (16) and gear housing (4) for assembly.
- 9. Remove ten screws (14), lockwashers (15), cylinder head (16), and gasket (17) from gear housing (4). Discard lockwashers and where

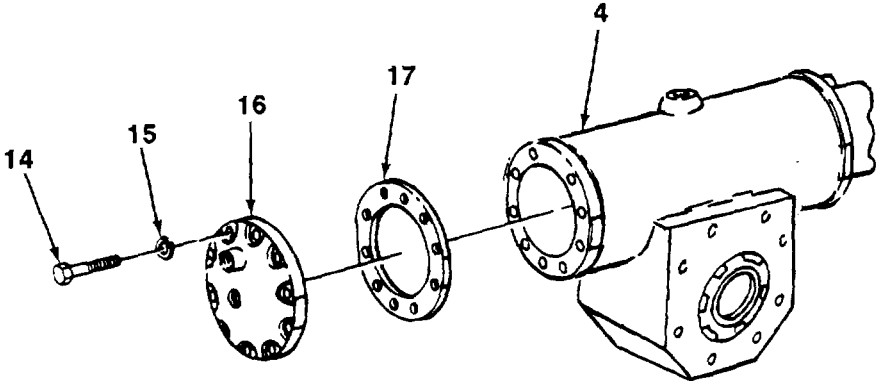

- 10. Make alinement marks on housing cover (19) and gear housing (4) for assembly.
- 11. Remove ten screws (21) and lockwashers (22) from housing cover (19). Discard lockwashers.
- 12. Rotate housing cover (19) and actuating shaft (20) counterclockwise to remove from gear housing (4).
- 13. Remove gasket (18). Discard gasket.

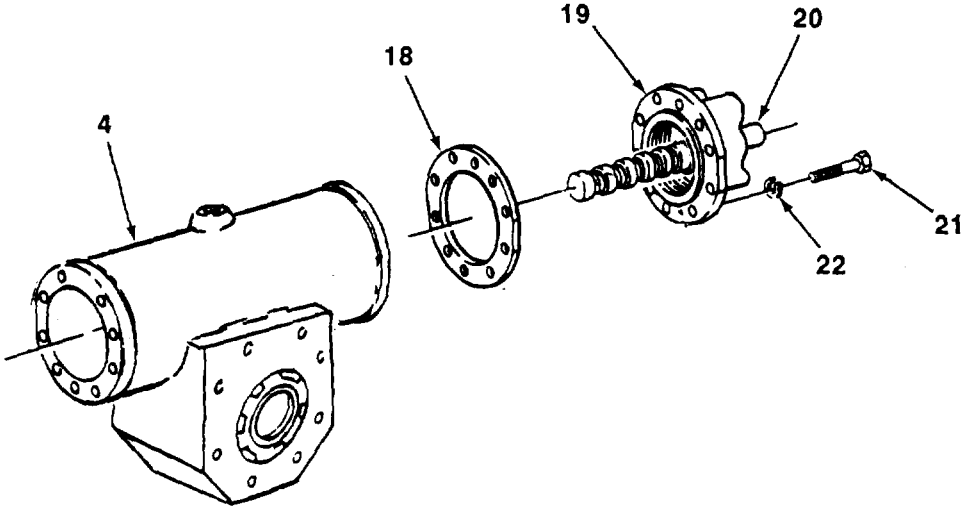

12-2. LEFT POWER STEERING GEAR REF

14. Remove lockpin (26) from housing cover (19).
15. Remove retaining nut (23) from housing cover (19) by rotating counterclockwise.
16. Press actuating shaft (20) out of housing cover (19).
17. Remove seal (25) and inner seal (24) from housing cover (19). Discard seals.

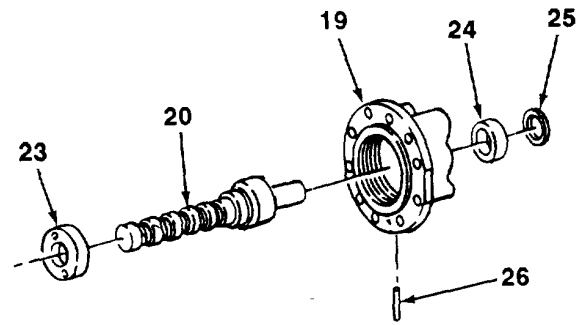

NOTE

Note position of piston in gear housing for assembly.

18. Remove piston (28) from gear housing (4).
19. Remove packing assembly (27) from gear housing (4). Discard packing assembly.
20. Make alignment marks on piston (28) and bearing nut (30) for assembly.
21. Remove locking pin (32), bearing nut (30), and reversing spring (31) from piston (28).

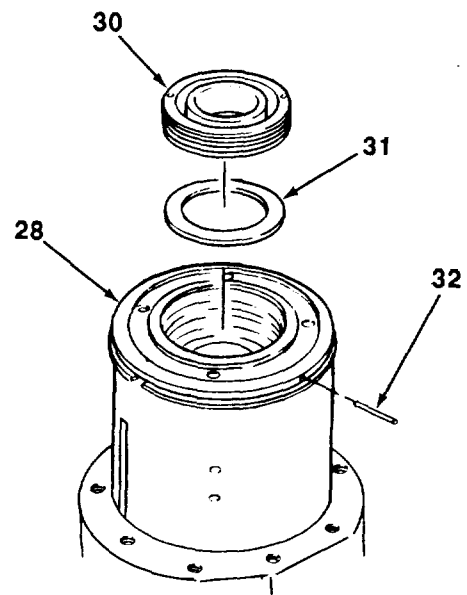
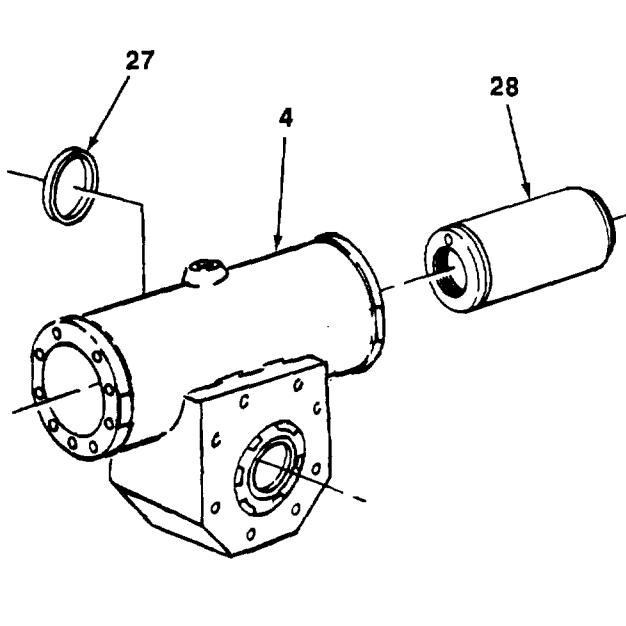

12-2. LEFT POWER STEERING GEAR REPAIR

22. Remove actuating valve (33), reversing spring (34), and spool (35) from piston (28).

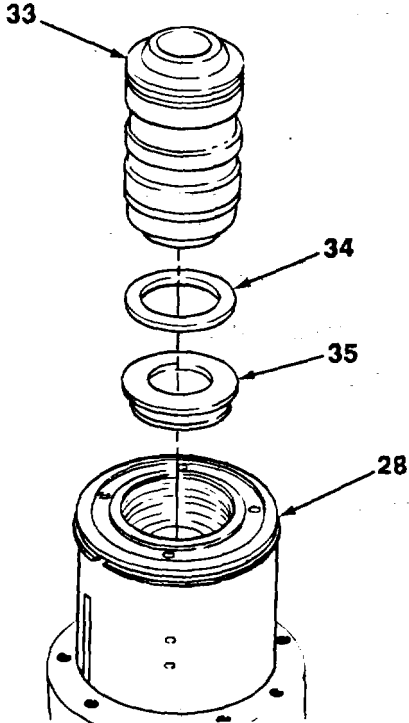

23. Remove valve positioning pin (36) and two piston rings (29) from piston (28).
24. Remove locking pin (41) and plug (42) from each end of piston (28).
25. Remove two washers (37), valve seats (38), balls (39), and spring (40) from piston (28).

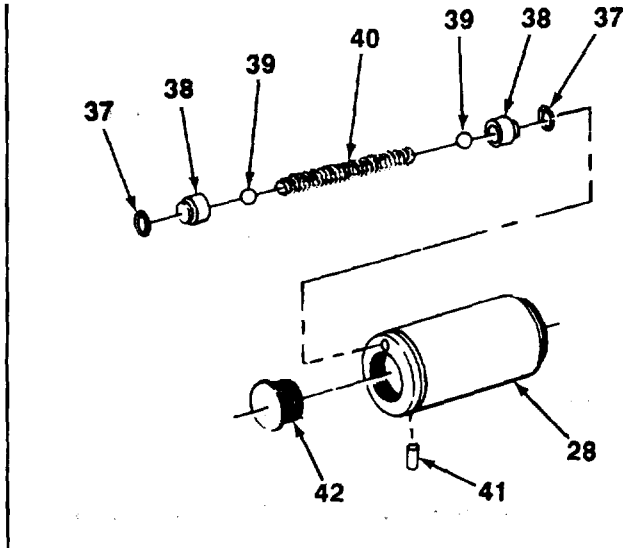
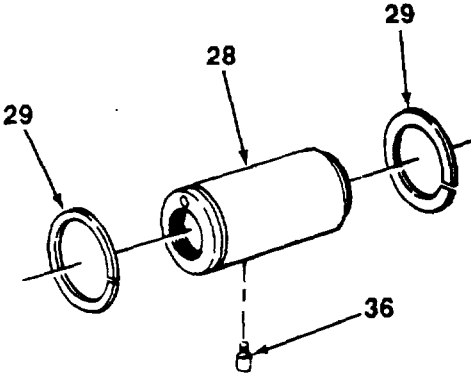

TA704019

12-2. LEFT POWER STEERING GEAR REPAIR (Con't).**b. CLEANING AND INSPECTION****WARNING**

Dry cleaning solvent, P-D-680, is toxic and flammable. Always wear protective goggles and gloves, and use only in a well-ventilated area. Avoid contact with skin, eyes, and clothes, and DO NOT breathe vapors. DO NOT use near open flame or excessive heat. The solvent's flash point is 1000F-138°F (38°C-590C). If you become dizzy while using cleaning solvent, immediately get fresh air and medical help. If solvent contacts eyes, immediately wash your eyes and get medical aid.

1. Clean metal parts with dry cleaning solvent.
2. Inspect metal parts for cracks, breaks, corrosion, or other damage. Replace damaged parts.
3. Inspect piston for nicks or burrs. Remove burrs or raised nicks with fine stone.
4. Inspect piston components for damage. If bearing nut, reversing springs, valves, spools, or piston rings are damaged, replace piston.
5. Inspect actuating shaft with bearing. If either shaft or bearing needs replacement, replace as an assembly.

NOTE

Note position of bushing in gear housing and housing cover for installation.

6. Inspect bushing (43) in gear housing (4) and bushing (44) in housing cover (7) for wear or damage. Remove

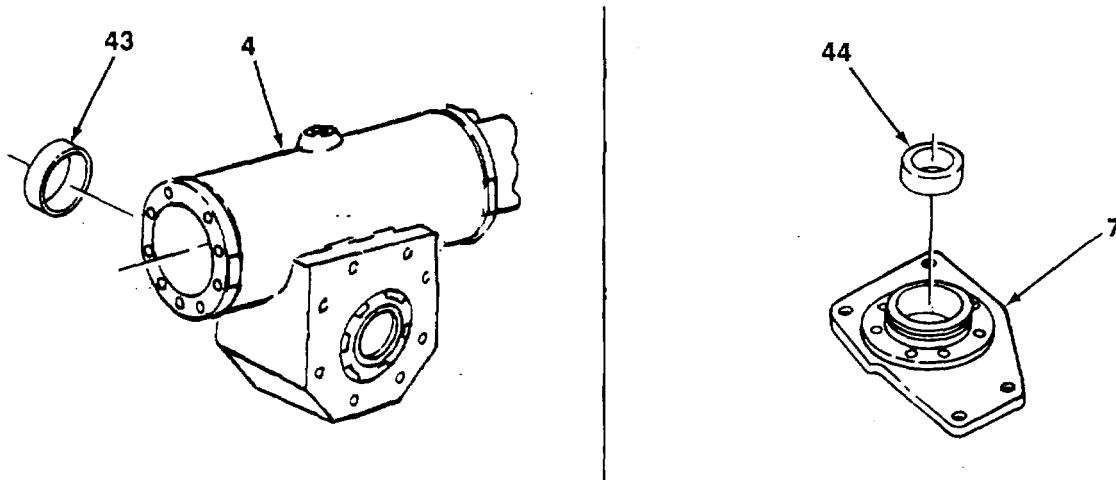
**c. ASSEMBLY****NOTE**

- Perform step 1 if bushing in gear housing or housing cover was removed.
- During assembly, align all alignment marks made during disassembly.

1. Install bushing (43 or 44) in gear housing (4) or housing cover (7).

TA704020

12-2. LEFT POWER STEERING GEAR REF

NOTE

Ensure that each valve seat is flush with or slightly below end surface of piston.

2. Install spring (40), two balls (39), two valve seats (38), and two washers (37) in piston (28).

NOTE

Ensure that plug is installed until flush with end of piston, then rotate plug until locking pin can be installed through piston and plug. Ensure that plug and locking pin are flush with or slightly below end surface of piston.

3. Install plug (42) and locking pin (41) in piston (28).

4. Install valve positioning pin (36) to side of piston (28).

NOTE

Piston rings that have a taper on one side or are marked TOP are installed with taper or marking facing outward toward end of piston. Piston rings not tapered or marked may be installed in either direction.

5. Install two piston rings (29) on piston (28).

6. Coat spool (35), reversing Spring (34), and actuating valve (33) with oil and install spool, reversing spring, and actuating valve in piston (28).
7. Coat reversing spring (31), bearing nut (30), and locking pin (32) with oil and install reversing spring, bearing nut, and locking pin in piston (28).

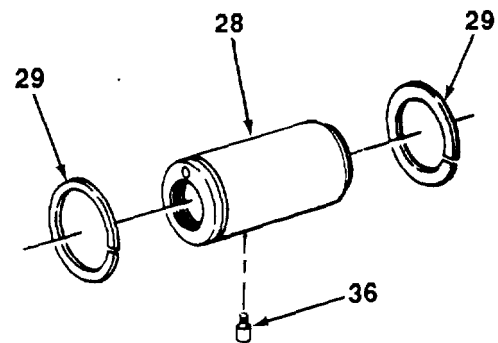
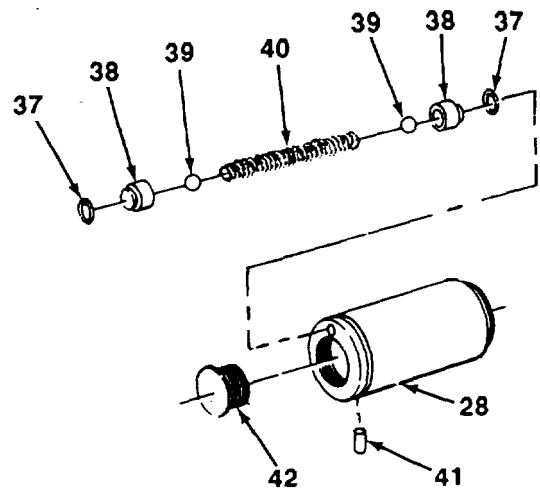

TA704021

12-2. LEFT POWER STEERING GEAR REPAIR (Con't).

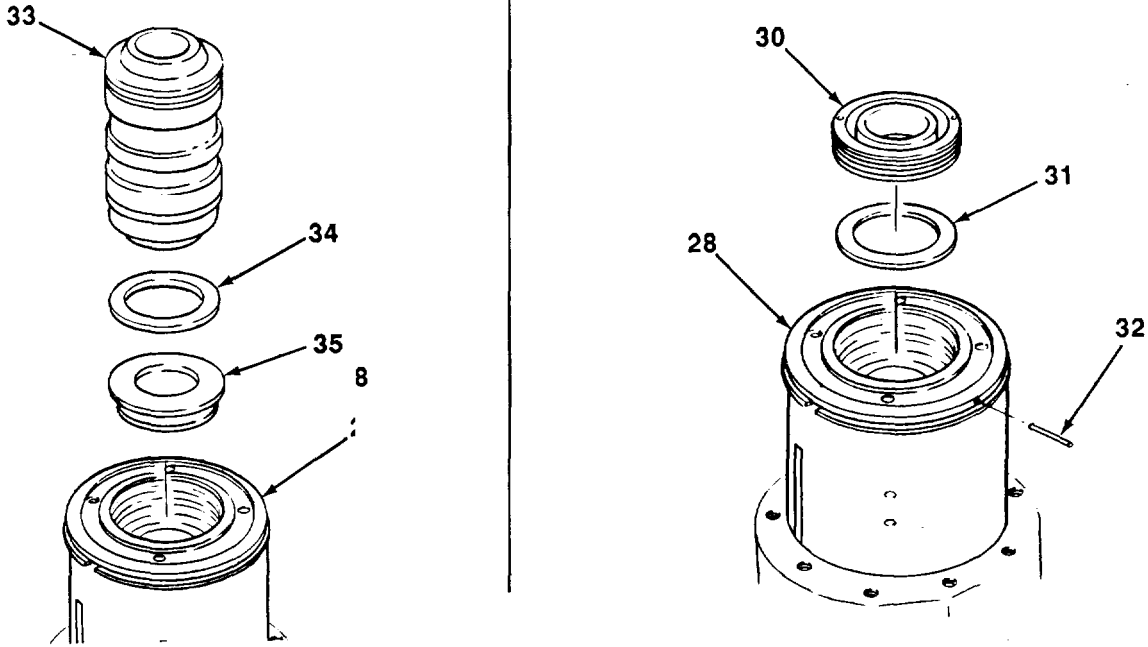

- 8. Install new packing assembly (27) in gear housing (4).
- 9. Coat piston (28) and piston rings (29) with oil, and install piston in gear housing (4) using piston ring compressor.
- 10. Coat new inner seal (24) and new seal (25) with oil, and install inner seal and seal in housing cover (19).
- 11. Coat actuating shaft (20) with oil and press into housing cover (19).
- 12. Install retaining nut (23) to housing cover (19) and install lockpin (26).

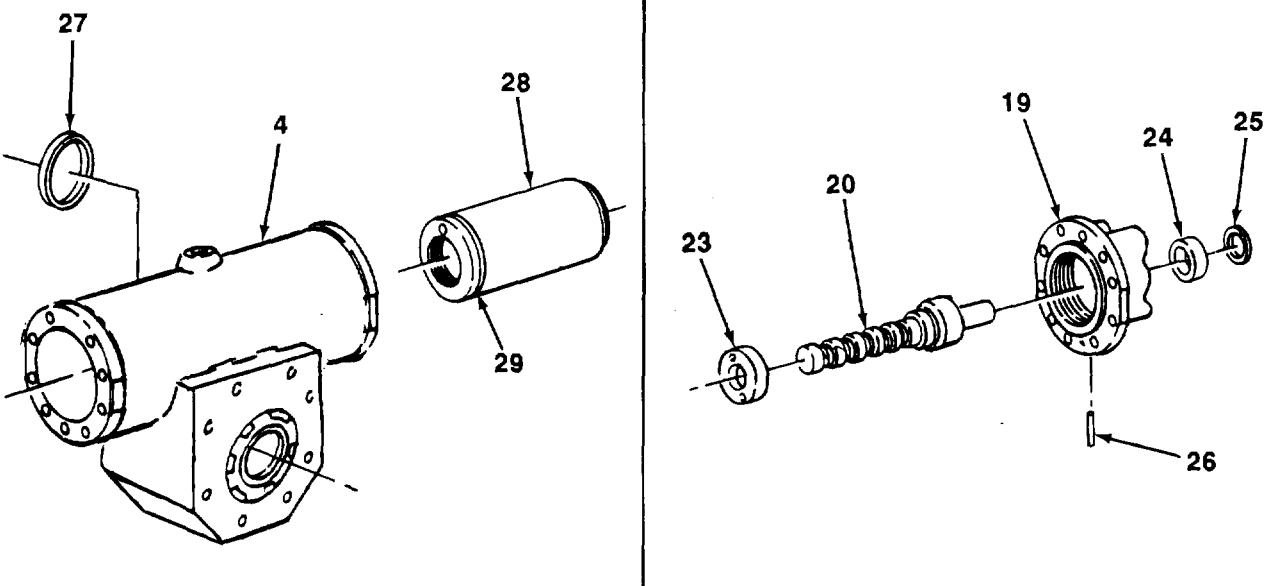

12-2. LEFT POWER STEERING GEAR REPAIR (Con't).

- 13. Install new gasket (18) to housing cover (19).
- 14. Rotate housing cover (19) and actuating shaft (20) clockwise to install to gear housing (4).
- 15. Install ten new lockwashers (22) and screws (21). Torque screws to 20 lb.-ft. (27 Nom).

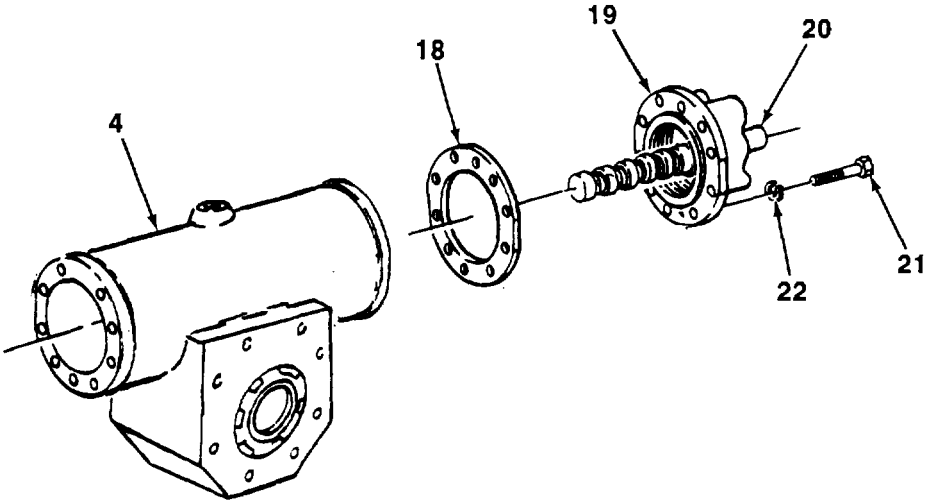

- 16. Install new gasket (17) and cylinder head (16) to gear housing (4) with ten new lockwashers (15) and screws (14). Torque screws to 20 lb.-ft. (27 Nom).

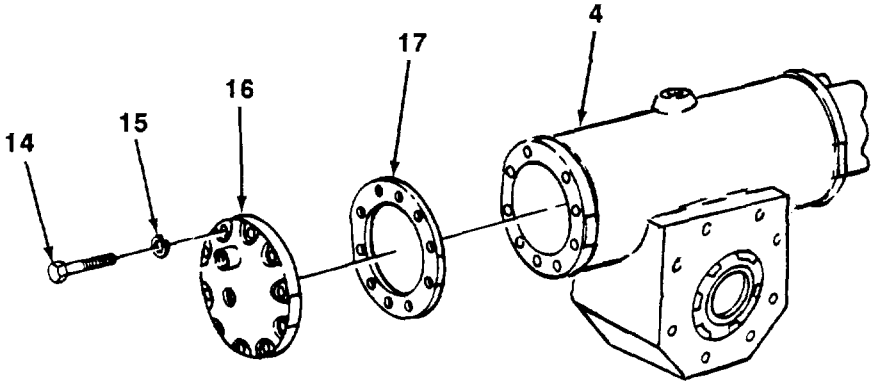

- 17. Press gear (12) on output shaft (13).
- 18. Install output shaft (13) into gear housing (4).

TA704023

12-2. LEFT POWER STEERING GEAR REPAIR (Con't).

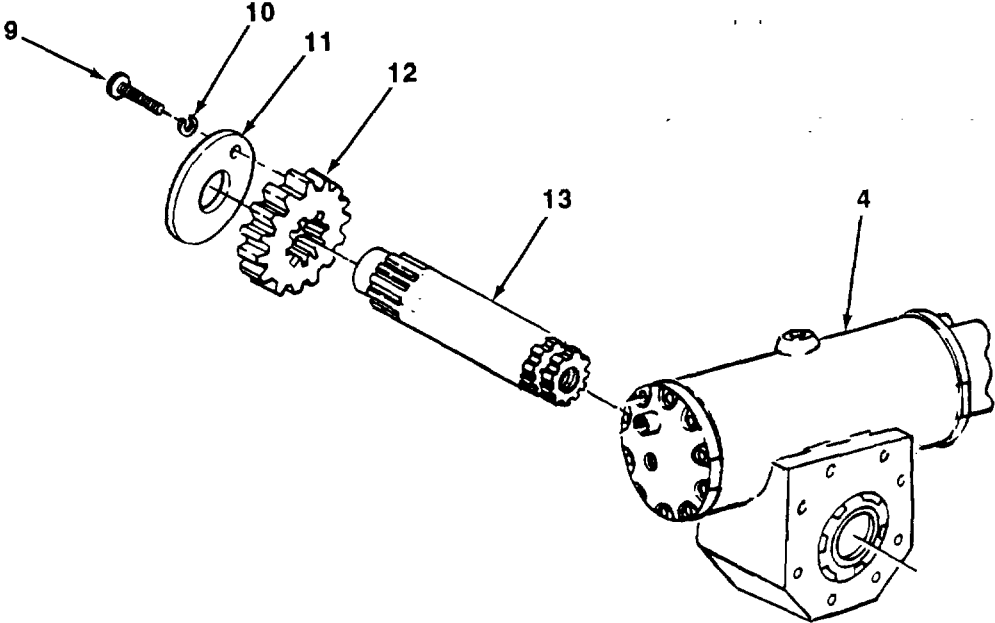

- 19. Install gear retaining nut (11) on output shaft (13). Tighten nut against gear (12), then loosen nut until holes in nut and gear align. Install two new lockwashers (10) and cap screws (9).
- 20. Install new preformed packing (8) on housing cover (7) and install housing cover to gear housing (4) with eight new lockwashers (6) and screws (5). Torque to 83 lb.-ft. (113 N•m).

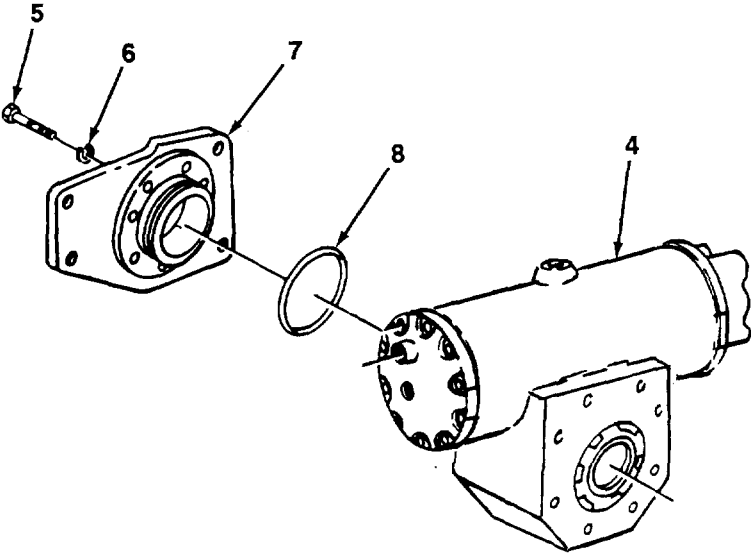

TA704024

12-2. LEFT POWER STEERING GEAR REPAIR (Con't).**NOTE**

Perform step 21 at each end of steering gear.

21. Install new preformed packing (3), nut (1), and relief valve plunger (2) in gear housing (4) by rotating relief valve plunger approximately six turns.

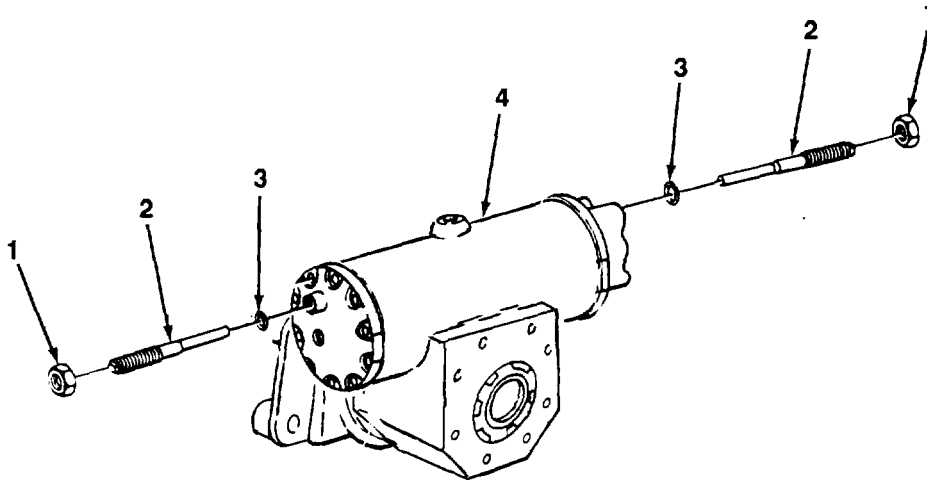
**FOLLOW-ON TASKS:**

- Install left power steering gear (see paragraph 12-1).
- Bleed and adjust steering system (see paragraph 12-4).

TA704025

12-3. RIGHT POWER STEERING GEAR I

This Task Covers:

- a. Disassembly
- b. Cleaning and Inspection

c. Assembly

Initial Setup:

Equipment Conditions:

- Right power steering gear removed (see paragraph 12-1).

Tools/Test Equipment:

- General mechanic's tool kit
- Field automotive shop set

Personnel Required: Two

General Safety Instructions:

- Dry cleaning solvent is flammable and must not be used near open flame. Use only in a well-ventilated area.
-

a. DISASSEMBLY I

1. Remove eight screws (4), lockwashers (5), and housing cover (3) from gear housing (1). Discard lockwashers.
2. Remove preformed packing (2) from housing cover (3). Discard preformed packing.

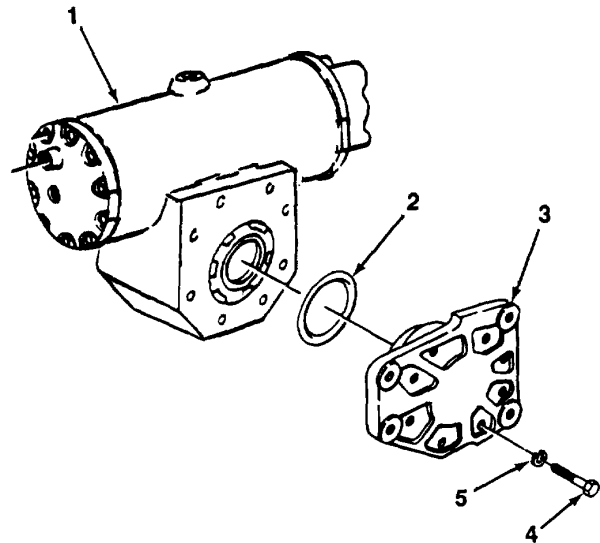

TA704026

12-3. RIGHT POWER STEERING GEAR REPAIR (Con't). - -m ' V

3. Remove two capscrews (10) and lockwashers (9) from gear retaining nut (8). Discard lockwashers.
4. Remove gear retaining nut (8) from output shaft (6) by rotating counterclockwise.

NOTE

Note position of alinement mark on center tooth of piston and gear for assembly.

5. Remove output shaft (6) and gear (7) assembly from gear housing (1).

NOTE

Note position of alinement mark on output shaft and gear for assembly.

6. Press gear (7) from output shaft (6).

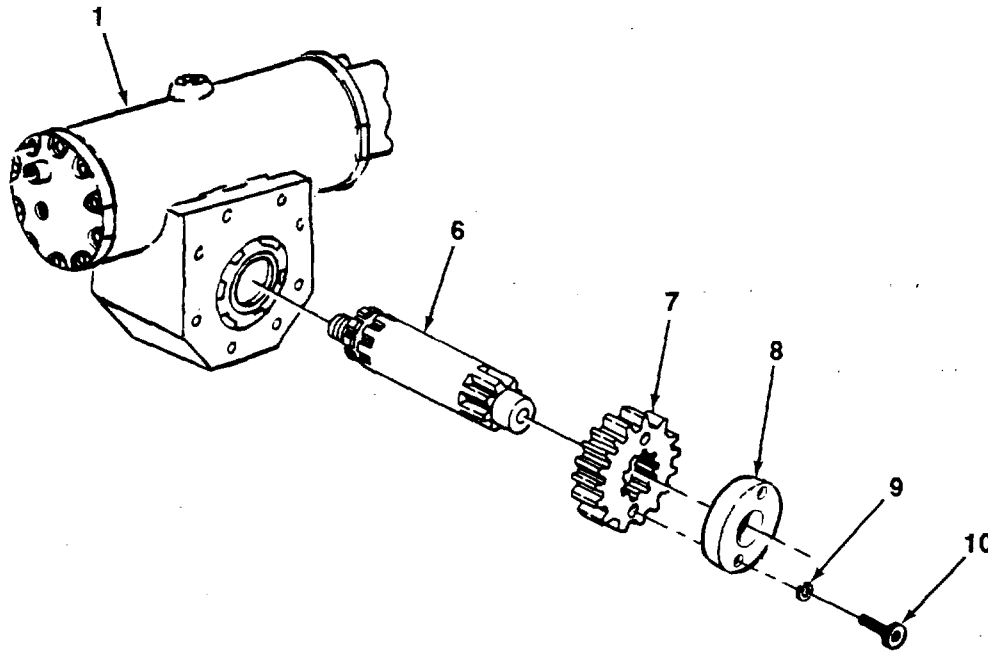

7. Make alinement marks on cylinder head (12), and gear housing (1) for assembly.
8. Remove ten screws (13), lockwashers (14), cylinder head (12), and gasket (11) from gear housing (1). Discard lockwashers and gasket.
9. Repeat step 8 for other cylinder head (12).

TA704027

12-3. RIGHT POWER STEERING GEAR REPAIR (Con't).

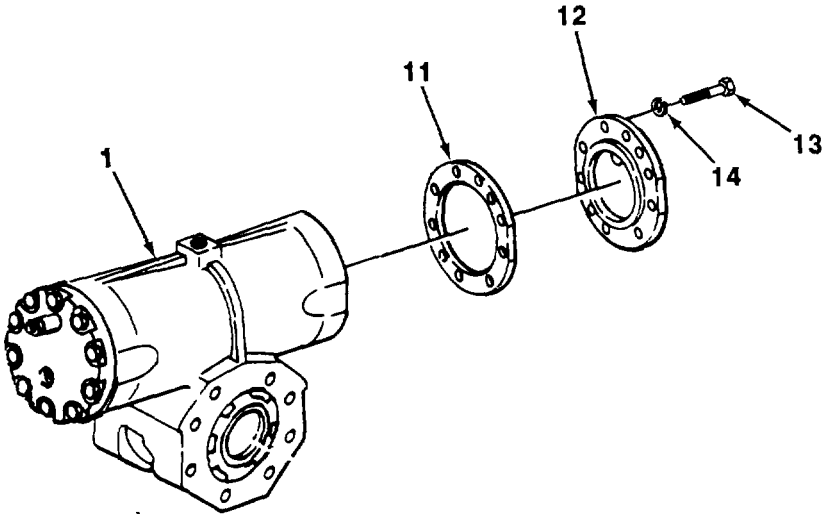

- 10. Remove piston (15) assembly from gear housing (1).
- 11. Remove packing assembly (17) from gear housing (1). Discard packing assembly.
- 12. Remove two piston rings (16) from piston (15).

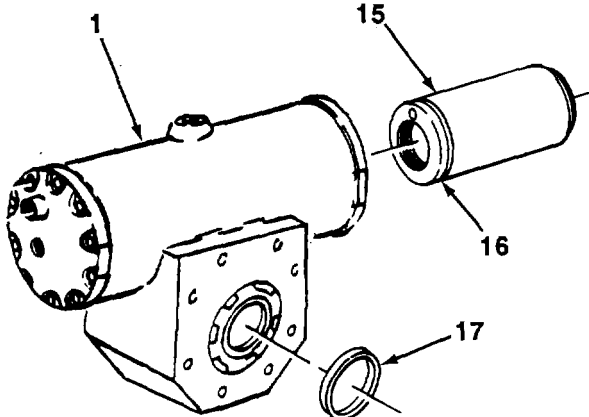

- 13. Remove locking pin (19) and plug (18) from other end of piston (15).
- 14. Remove valve seats (22), ball (21), and spring (20) from each plug (18).

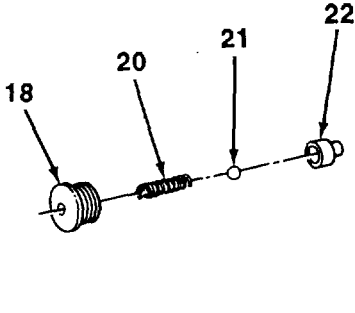
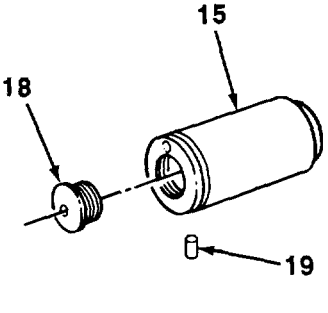

12-3. RIGHT POWER STEERING GEAR REPAIR (Con't).**b. CLEANING AND INSPECTION I****WARNING**

Dry cleaning solvent, PD680, is toxic and flammable. Always wear protective goggles and gloves, and use only in a well-ventilated area. Avoid contact with skin, eyes, and clothes, and DO NOT breathe vapors. DO NOT use near open flame or excessive heat. The solvent's flash point is 100°F/38°C (38°C/59°C). If you become dizzy while using cleaning solvent, immediately get fresh air and medical help. If solvent contacts eyes, immediately wash your eyes and get medical aid.

1. Clean metal parts with dry cleaning solvent.
2. Inspect metal parts for cracks, breaks, corrosion, or other damage. Replace damaged parts.
3. Inspect piston for nicks or burrs. Remove nicks or burrs with fine stone.
4. Inspect piston components for damage. If rings, pins, plugs, seats, or springs are damaged, replace piston.

NOTE

Note position of bushing in gear housing and housing cover for installation.

5. Inspect bushing (23) in gear housing (1) and bushing (24) in housing cover (3) for wear or damage. Remove bushing (23 or 24) using puller if worn or damaged. Discard bushings.

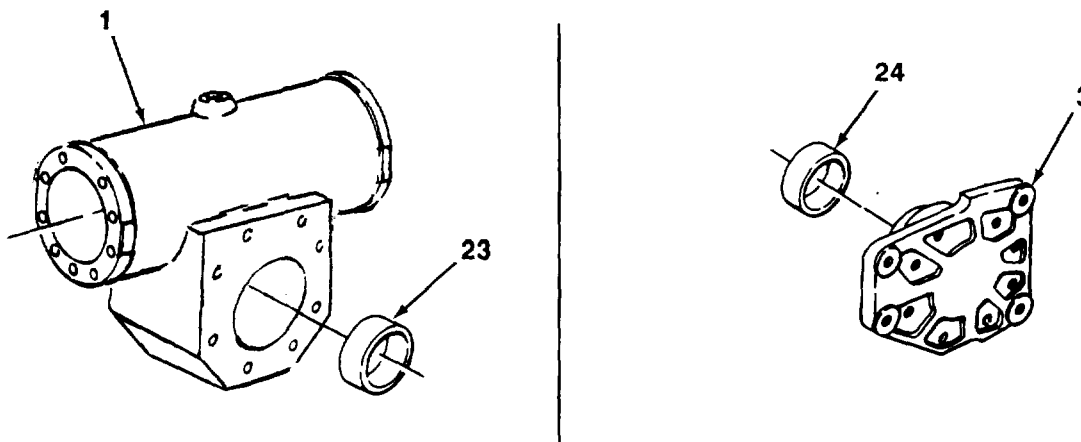
**c. ASSEMBLY****NOTE**

- Perform step 1 if bushing in gear housing or housing cover was removed.
- During assembly, align all alignment marks made during disassembly.

1. Install bushing (23 or 24) in gear housing (1) or housing cover (3).

TA704029

12-3. RIGHT POWER STEERING GEAR REPAIR (Con't).

2. Install spring (20), ball (21), and valve seats (22) to each plug (18).

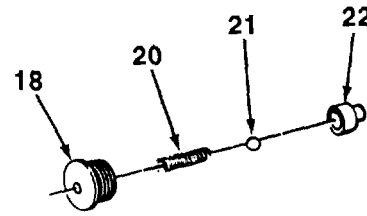

NOTE

Ensure that plug is installed until flush with end of piston, then rotate plug until locking pin can be installed through piston and plug. Ensure that plug and locking pin are flush.

3. Install plug (18) and locking pin (19) in piston (15).

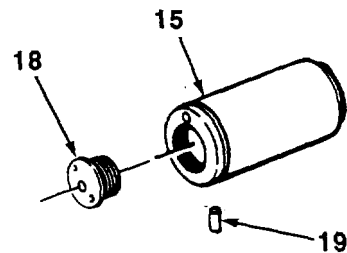

NOTE

Piston rings that have a taper on one side or are marked TOP are installed with taper or marking facing outward toward end of piston. Piston rings not tapered or marked may be installed in either direction.

4. Install two piston rings (16) on piston (15).
5. Install new packing assembly (17) in gear housing (1).
6. Coat piston (15) and piston rings (16) with oil, and install piston in gear housing (1) using piston ring compressor.

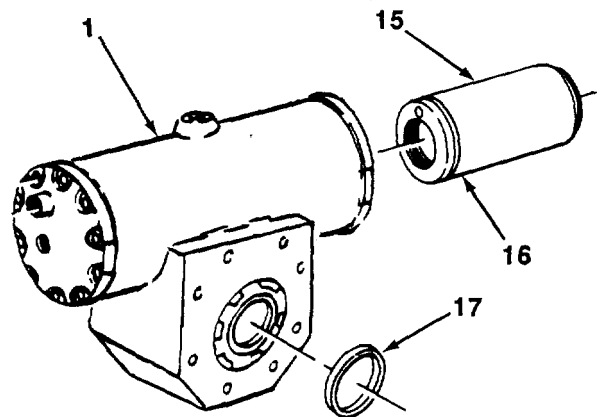

TA704030

12-3. RIGHT POWER STEERING GEAR REPAIR (Con't).

NOTE

Perform step 7 at each end of gear housing.

- 7. Install new gasket (11) and cylinder head (12) on gear housing (1) with ten new lockwashers (14) and screws (13). Torque to 20 lb.-ft. (27 N-m).

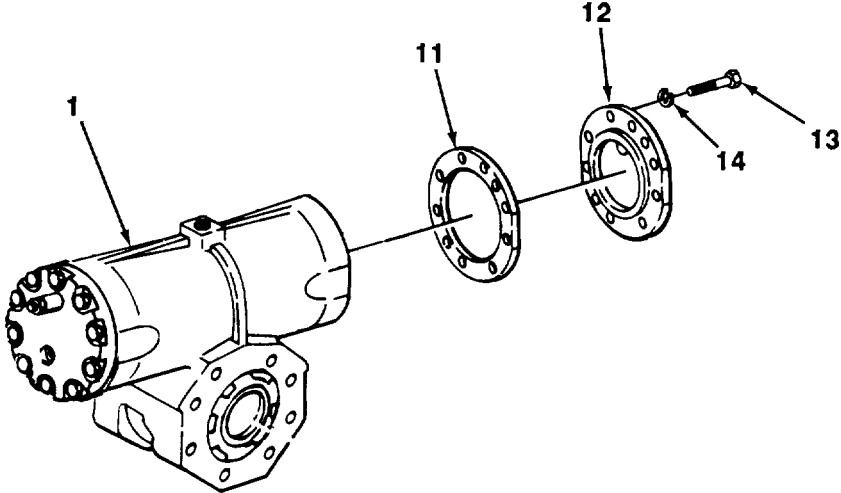

- 8. Press gear (7) on output shaft (6).
- 9. Install output shaft (6) in gear housing (1).
- 10. Install gear retaining nut (8) on output shaft (6). Tighten nut against gear (7), then loosen nut until holes in nut and gear align. Install two new lockwashers (9) and capscrews (10).
- 11. Install new preformed packing (2) on housing cover (3) and install housing cover to gear housing (1) with eight new lockwashers (5) and screws (4). Torque screws to 83 lb.ft. (113 N.m).

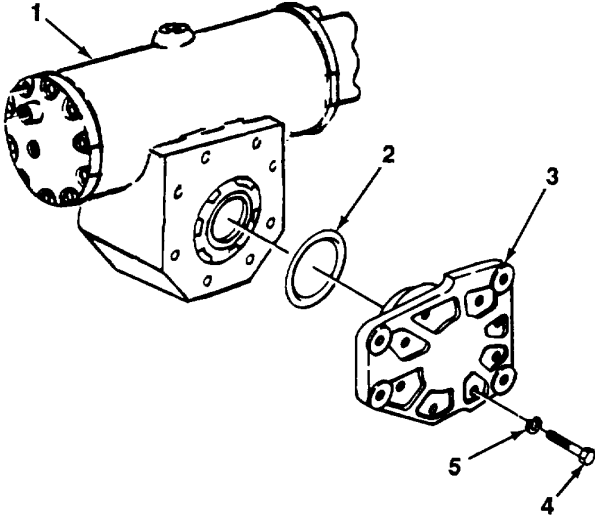

TA704031

12-3. RIGHT POWER STEERING GEAR REPAIR (Con't).

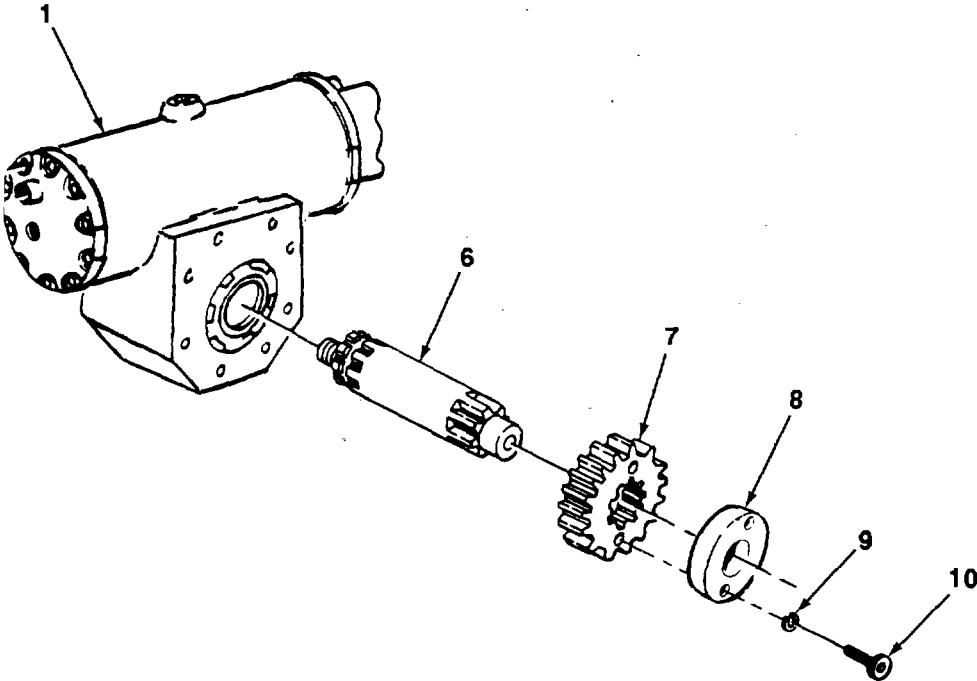

FOLLOW-ON TASKS:

- Install right power steering gear (see paragraph 12-1).
- Bleed and adjust steering system (see paragraph 12-4).

TA704032

12-4. BLEED AND ADJUST STEERING SYSTEM.

This Task Covers:

- | | |
|----------|-----------|
| a. Bleed | b. Adjust |
|----------|-----------|
-

Initial Setup:

Equipment Conditions:

- Parking brake set (see TM 5-3805-254-10).
- Steering system filled (see TM 5-3805-254-20).
- Steering arm disconnected (see paragraph 12-5).

Materials/Parts:

- Lubricating oil (Item 13, Appendix B)

Reference:

- TM 5-3805-254-10
- TM 5-3805-254-20

Tools/Test Equipment:

- General mechanic's tool kit

Personnel Required: Two

a. BLEED

1. Start engine (see TM 5-3805-254-10).
2. Turn steering wheel left and right three times to remove air in steering system.
3. Stop engine (see TM 5-3805-254-10).
4. Fill steering system (see TM 5-3805-254-20).

b. ADJUSTI

1. Connect steering arm (see paragraph 12-5).

NOTE

Steering gear is adjusted by rotating relief valve plunger at each end of steering gear.

2. Loosen two nuts (2) on each end of steering gear (3).
3. Rotate two relief valve plungers (1) clockwise until they bottom.
4. Start engine (see TM 5-3805-254-10) and operate at fast idle.
5. Rotate steering wheel to right until steering wheel starts to turn hard.

NOTE

Do not disturb wheel stop to gain clearance while performing steps 6 and 7.

6. While holding steering wheel to the right, adjust relief valve plunger (1) at rear of steering gear (3) outward (counterclockwise) until there is approximately Y in. (3 mm) clearance between wheel stop (5) and right side of front axle (4).
7. While holding steering wheel to the left, adjust relief valve plunger (1) at rear of steering gear (3) outward (counterclockwise) until there is approximately X in. (3 mm) clearance between wheel stop (6) and left side of front axle (4).

12-4. BLEED AND ADJUST STEERING SYSTEM (Con't).

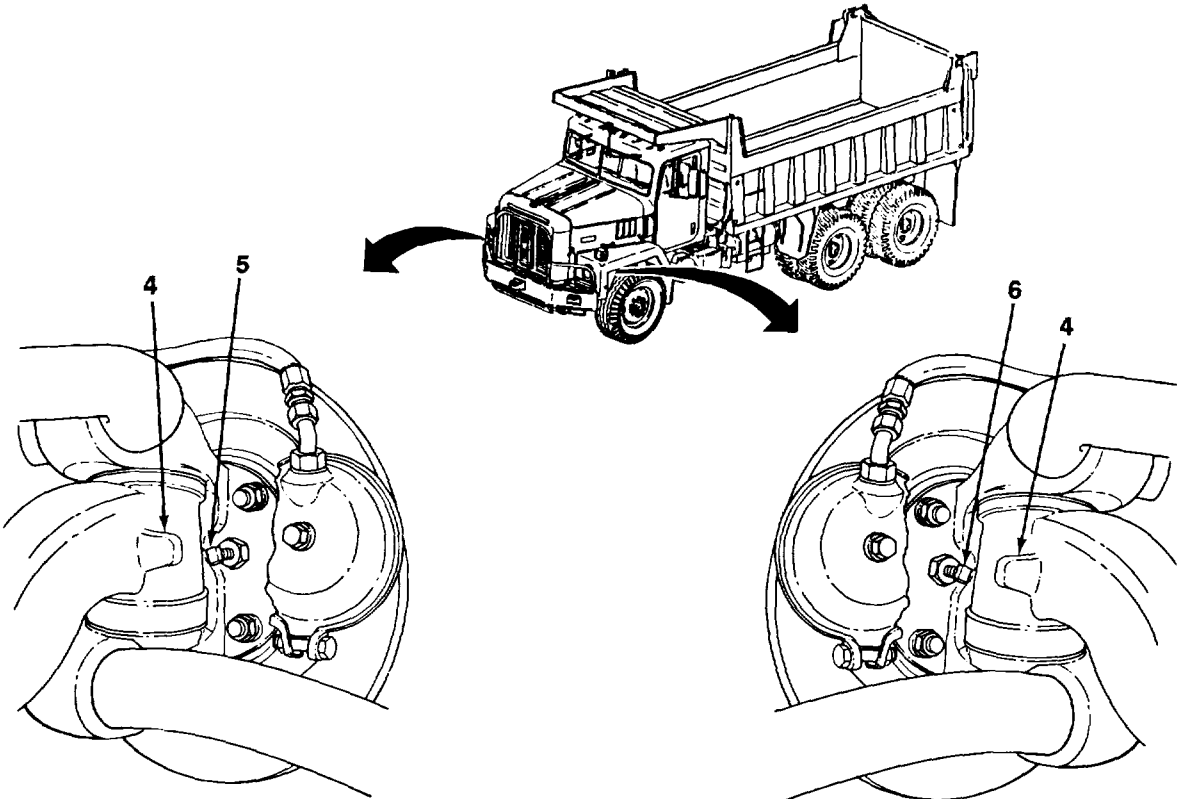
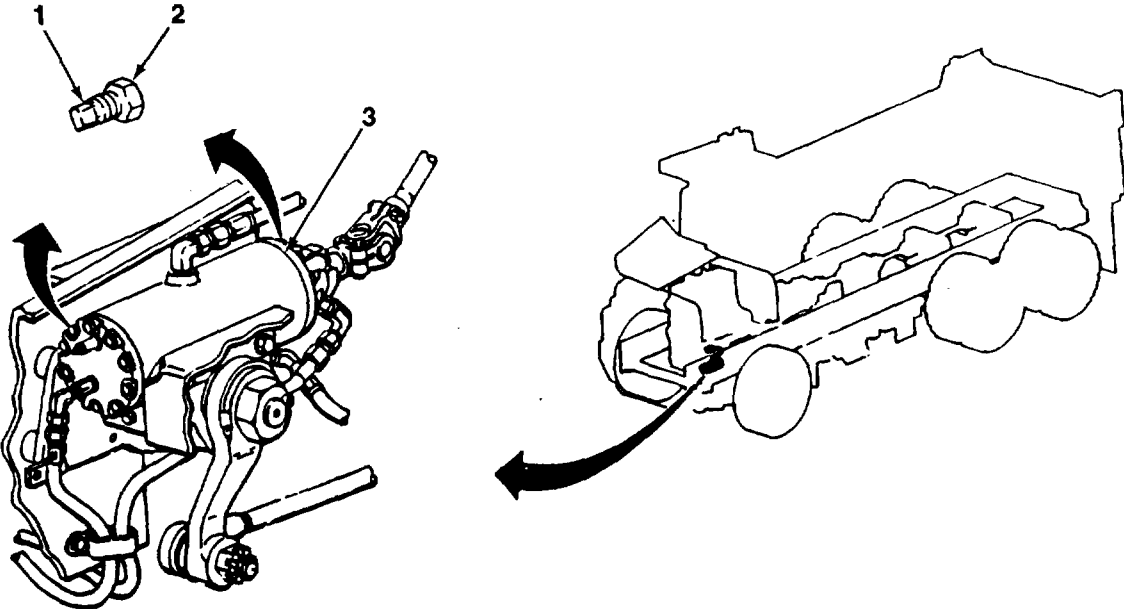

TA704033

12-4. BLEED AND ADJUST STEERING SYSTEM (Con't).

- 8. Stop engine (see TM 5-3805-254-10).
- 9. Tighten two nuts (2) at each end of steering gear (3) without disturbing relief valve plungers (1).

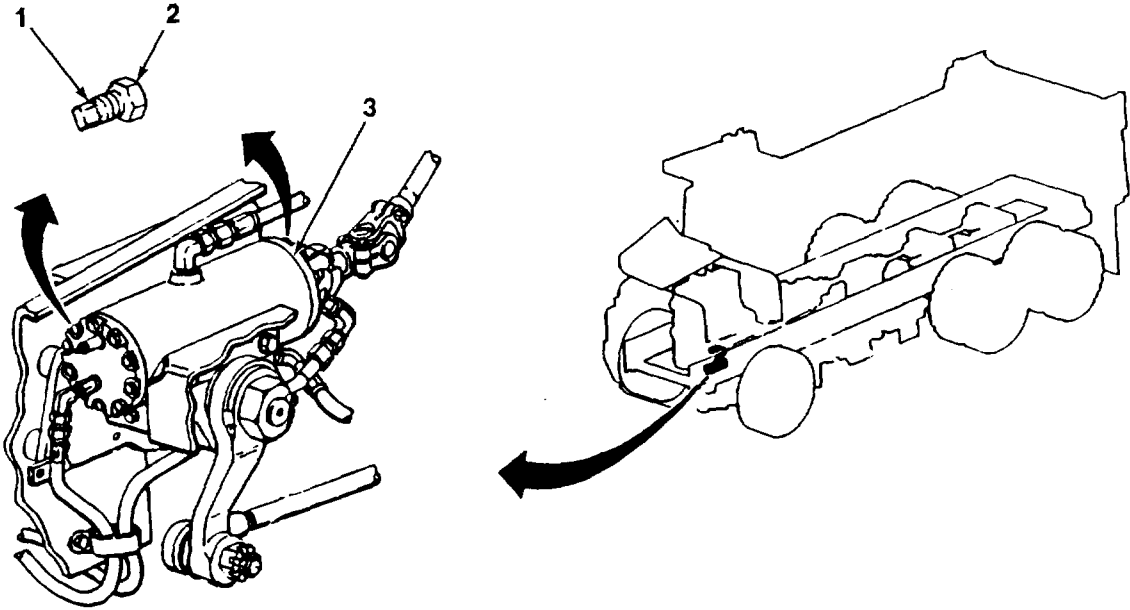

TA704034

12-5. STEERING ARMS REPLACEMENT.

This Task Covers:

- a. Removal b. Installation
-

Initial Setup:

Materials/Parts:

- One cotter pin
- One lockwasher

Tools/Test Equipment:

- General mechanic's tool kit
 - Field automotive shop set
-

a. REMOVAL

NOTE

Perform following steps to remove steering arm from steering gear and drag link at either left or right side of vehicle.

1. Remove cotter pin (2) and slotted nut (3) at front end of drag link (1). Discard cotter pin.
2. Loosen end of drag link (1) from steering arm (4).

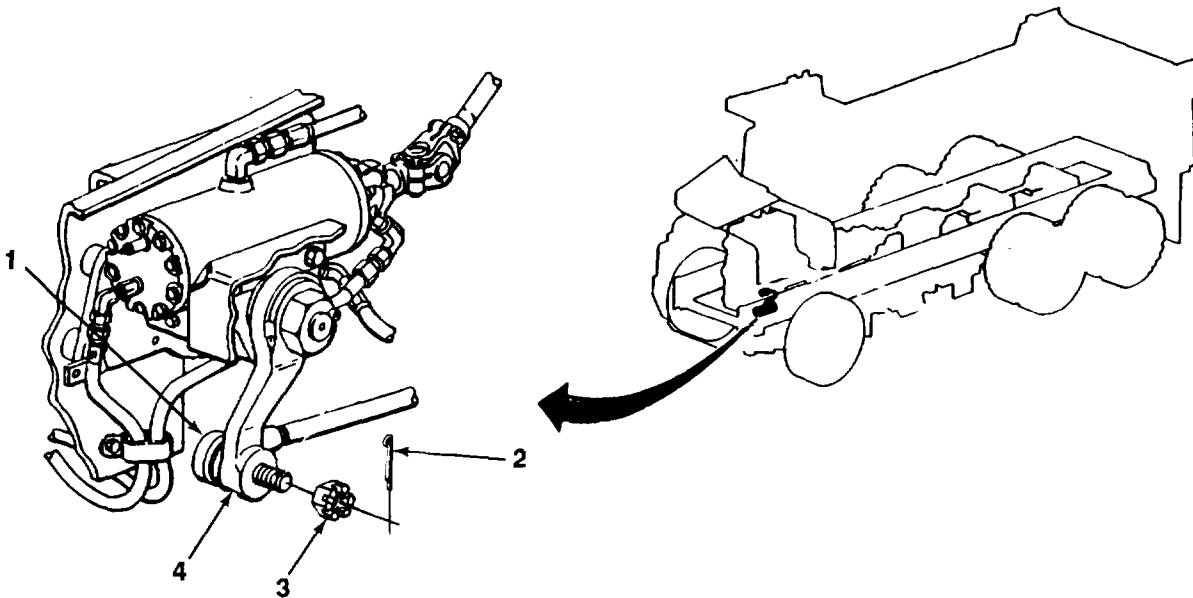

TA704035

12-5. STEERING ARMS REPLACEMENT (Con't)

3. Remove screw (8) and lockwasher (7) from nut (6). Discard lockwasher.
4. Remove nut (6).

NOTE

Note position of steering arm on steering gear output shaft for assembly.

5. Using puller, remove steering arm (4) from steering gear output shaft (5) and drag link (1).

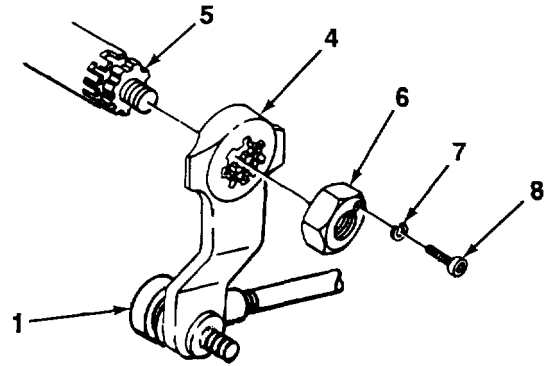

b. INSTALLATION

NOTE

- Perform the following steps to Install steering arm to steering gear and drag link at either left or right side of vehicle.
- To provide proper alinement of steering arm to steering gear output shaft, an arrow is stamped on steering arm and an arrow or dot is stamped on steering gear output shaft. These marks must be alined when steering arm is Installed on steering gear output shaft.

1. Install steering arm (4) on steering gear output shaft (5) and front end of drag link (1).
2. Install nut (6). Torque nut to approximately 450 lb.ft. (610 Nom) and until screw (8) can be installed through nut and into threaded hole of steering gear output shaft (5).
3. Install new lockwasher (7) and screw (8) to nut (6).
4. Install front end of drag link (1) to steering arm (4) with slotted nut (3) and new cotter pin (2).

TA704036

12-5. STEERING ARMS REPLACEMENT (Con't).

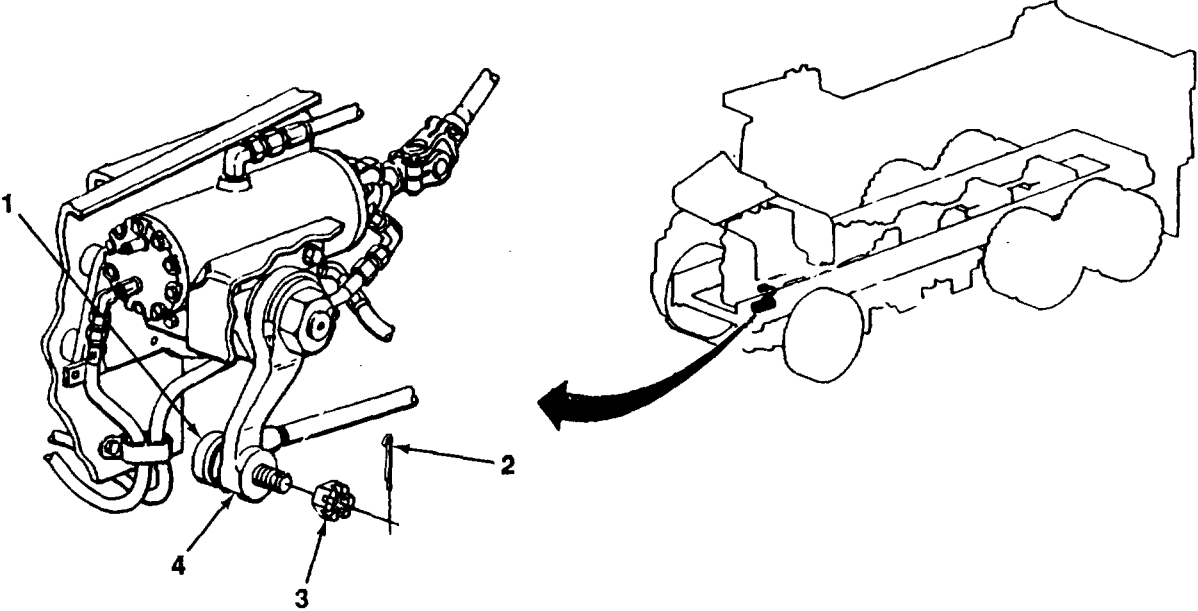

TA704037

12-6. STEERING COLUMN MAINTENANCE

This Task Covers:

- a. Removal
- b. Disassembly
- c. Cleaning and Inspection
- d. Assembly
- e. Installation

Initial Setup:

Equipment Conditions:

- Hood opened (see TM 5-3805-254-10).
- Steering wheel removed (see paragraph 12-9).
- Turn signal switch removed (see TM 5-3805-254-20).

Tools/Test Equipment:

- General mechanic's tool kit
- Field automotive shop set

References:

- LO 5-3805-254-12

Materials/Parts:

- Detergent (Item 6, Appendix B)
- Dry cleaning solvent (Item 23, Appendix B)
- One locknut
- One seal
- One seal washer
- Two repair kits
- Four cotter pins

General Safety Instructions:

- Dry cleaning solvent is flammable and must not be used near open flame. Use only in a well-ventilated area.

a. REMOVAL

1. Replace nut (1) loosely on end of drive shaft (2).
2. Disconnect lead and roller (3) from connector (4).
3. Remove two nuts (5), screws (8), four washers (6), and cover (9) from jacket tube (7).

NOTE

Note position of pin in steering column bracket and hole in jacket tube for assembly.

4. Remove two nuts (10), screws (13), four washers (11), and steering column cap (12) from steering column bracket (14).

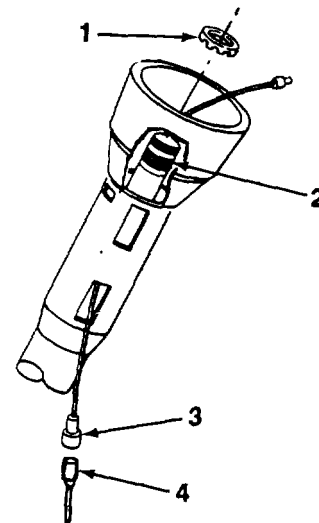

TA704038

12-6. STEERING COLUMN REPLACEMENT (Con't).

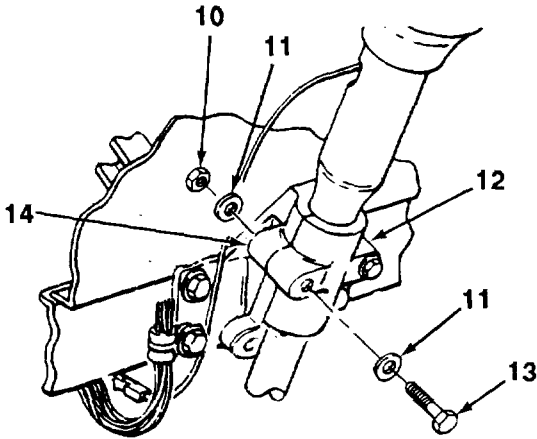
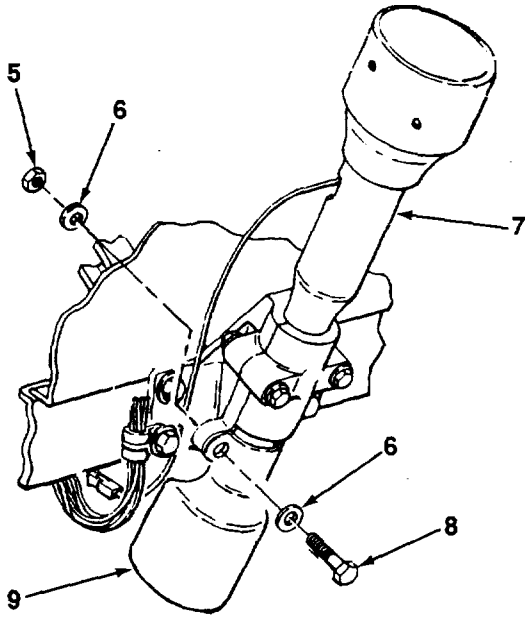

NOTE

Slip yoke of lower steering column will separate from drive shaft as upper steering column is removed.

- 5. Remove Jacket tube (7) from steering column bracket (14) and drive shaft (15).

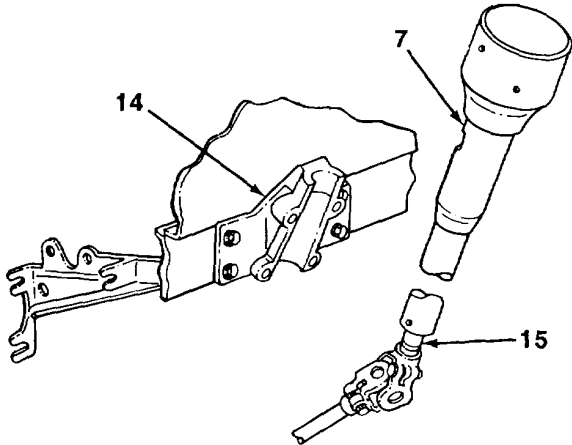

TA704039

12-6. STEERING COLUMN REPLACEMENT (Con't).

6. Remove remaining three nuts (16), bolts (18), eight washers (17), and steering column bracket (14) from instrument panel (19).
7. Remove two screws (20), washers (21), and steering column brace (22) from firewall.

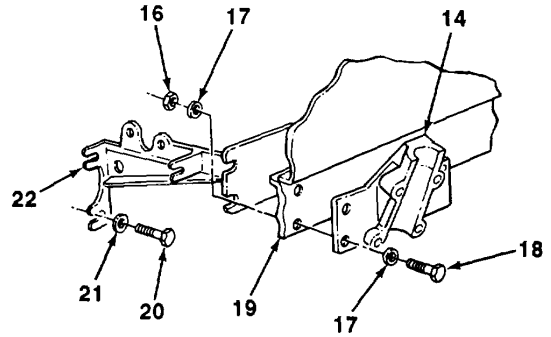

NOTE

Perform steps 8 through 12 to remove remaining lower steering column components

8. Remove four screws (25), retainer (23), and rubber boot (24) from firewall.

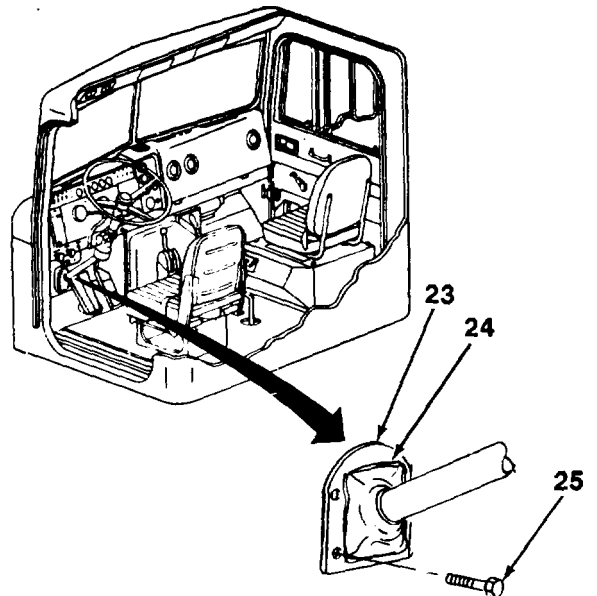

TA704040

TA704040

12-6. STEERING COLUMN REPLACEMENT (Con't).**NOTE**

Perform step 9 for upper and lower steering yokes.

9. Remove cotter pin (28), slotted nut (27), and screw (26) from yoke (29). Discard cotter pin.
10. Remove two yokes (29) from steering gear input shaft (31) and from drive shaft (15).
11. Remove lower drive shaft (30) from vehicle.
12. Repeat step 9 for two yokes.(32) on lower drive shaft (30).

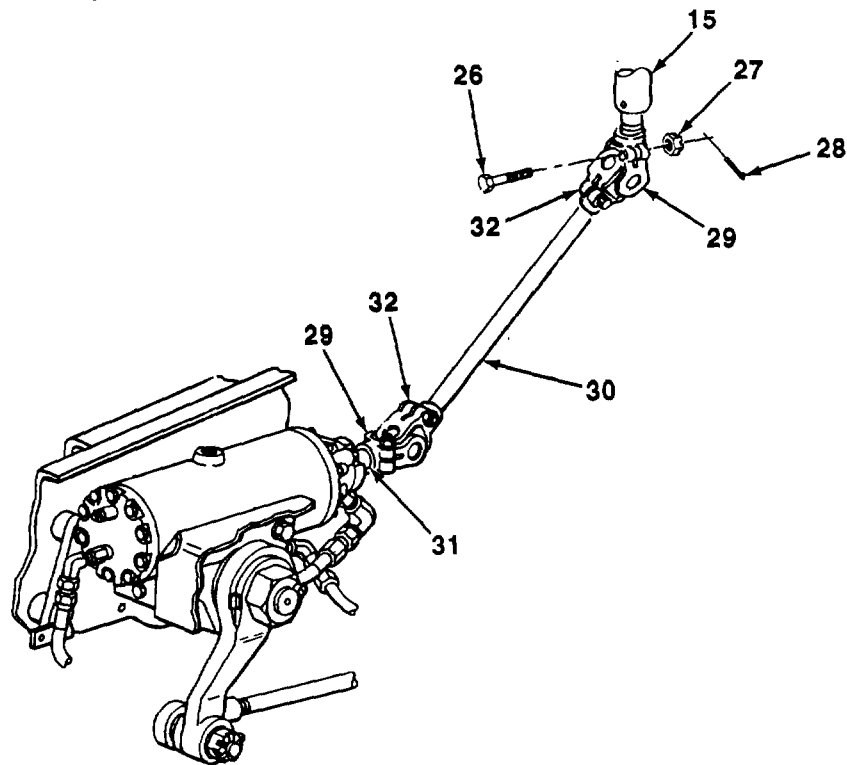

TA704041

12-6. STEERING COLUMN REPLACEMENT (Con't)

b. DISASSEMBLY

NOTE

Perform steps 1 through 3 for each universal joint.

1. Remove and discard two snaprings (33), bearings (34), and seals (35) from yoke (32).
2. Remove and discard lubrication fitting (37) from universal (36).
3. Remove and discard two snaprings (33), bearings (34), seals (35), and universal (36) from yoke (29).

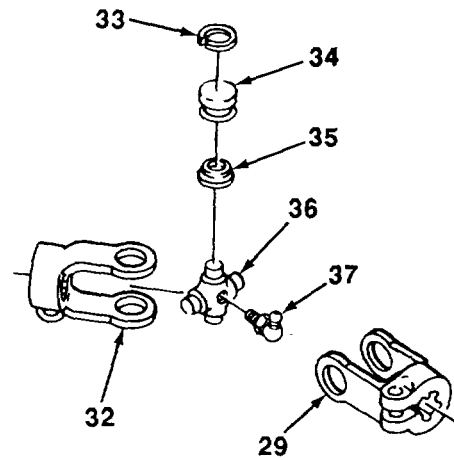

4. Remove dust cap (38), seal washer (39), and seal (40) from drive shaft (15). Discard seal washer and seal.
5. Remove two locknuts (42), washers (43), and clamp bolts (44) from steering column flange (41) to disconnect lead and roller (3). Discard locknuts.

TA704042

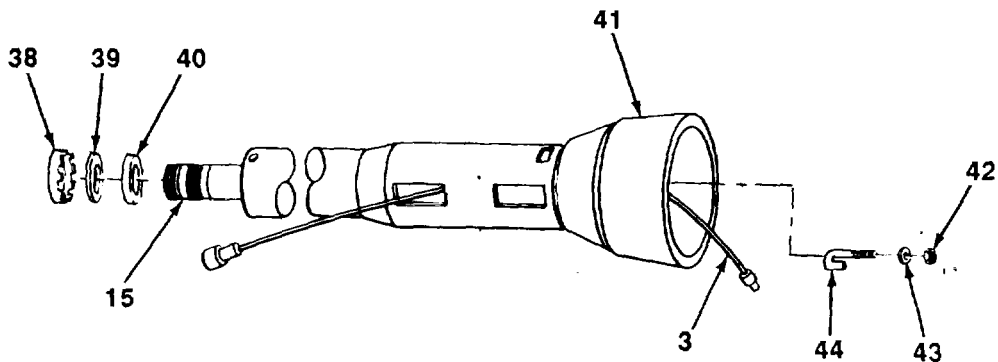

12-6. STEERING COLUMN REPLACEMENT (Con't).

6. Remove nut (1) and steering column flange (41) from jacket tube (7).
7. Remove lead and roller (3) from jacket tube (7).
8. Remove spacer (45), seat (46), upper bearing (47), and jacket tube (7) from drive shaft (15).
9. Remove dust cap (50), spring (51), seat (49), and bearing assembly (48) from drive shaft (15).

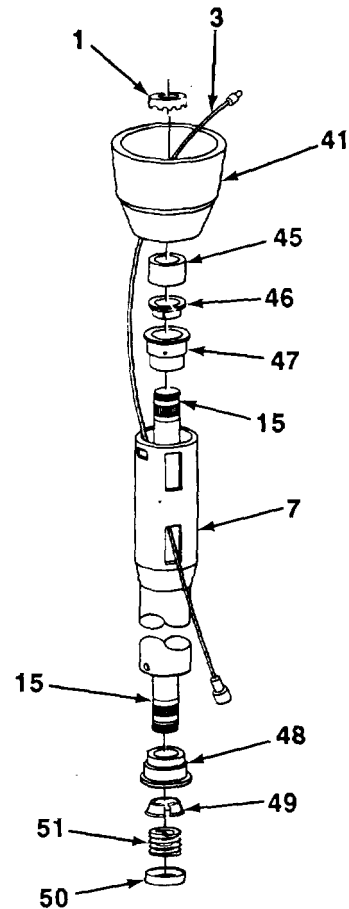
**c. CLEANING AND INSPECTION****WARNING**

Dry cleaning solvent, PD680, is toxic and flammable. Always wear protective goggles and gloves, and use only in a well-ventilated area. Avoid contact with skin, eyes, and clothes, and **DO NOT** breathe vapors. **DO NOT** use near open flame or excessive heat. The solvent's flash point is 100°F/38°C (380C/590C). If you become dizzy while using cleaning solvent, immediately get fresh air and medical help. If solvent contacts eyes, immediately wash your eyes and get medical aid.

1. Clean metal parts with dry cleaning solvent.
2. Inspect metal parts for cracks, breaks, and other damage. Replace if damaged.
3. Clean plastic parts with detergent and water solution.
4. Inspect plastic parts for cracks, breaks, and other damage. Replace if damaged.

TA704043

12-6. STEERING COLUMN REPLACEMENT (Con)**d. ASSEMBLY**

1. Install bearing assembly (48), seat (49), spring (51), and dust cap (50) to drive shaft (15).
2. Install jacket tube (7), upper bearing (47), seat (46), and spacer (45) to drive shaft (15).
3. Install lead and roller (3) in jacket tube (7).
4. Install steering column flange (41) to jacket tube (7). Loosely install nut (1) to drive shaft (15).

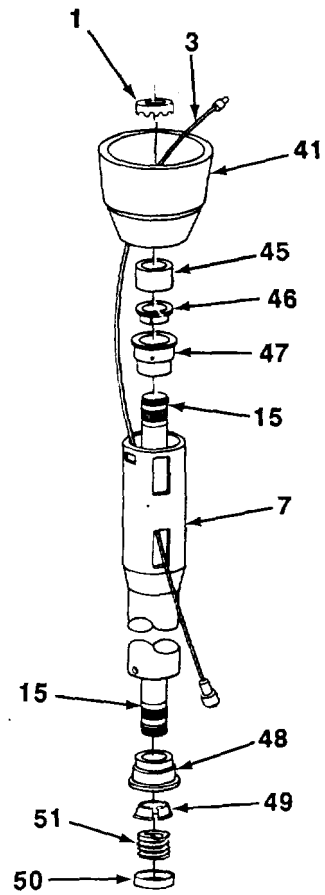

TA704044

12-6. STEERING COLUMN REPLACEMENT (Con't).

5. Connect lead and roller (3) to steering column flange (41) with two clamp bolts (44), washers (43), and new locknuts (42).
6. Install new seal (40), new seal washer (39), and dust cap (38) to drive shaft (15).

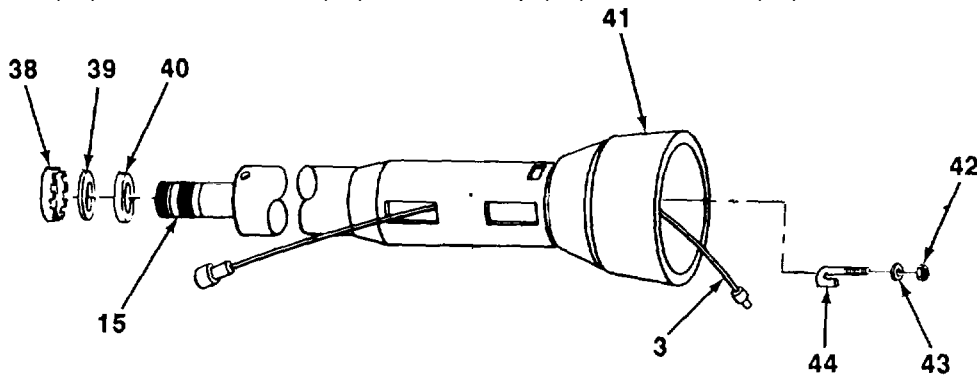

7. Install lubrication fitting (37) to universal (36).

NOTE

Perform steps 8 and 9 for each of two universal joints.

8. Install new universal (36), two new seals (35), new bearings (34), and new snaprings (33) to yoke (32).
9. Install new universal (36), two new seals (35), new bearings (34), and new snaprings (33) to yoke (29).
10. Lubricate lubrication fittings (37) (see LO 5380525412).

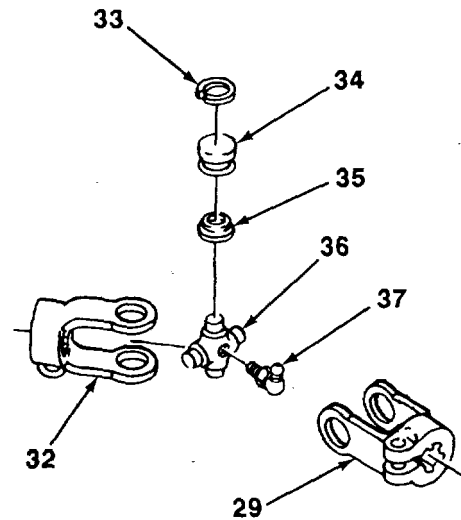

12-6. STEERING COLUMN REPLACEMENT (Con't).

e. INSTALLATION I**NOTE**

Perform steps 1 through 4 to install lower steering column components to vehicle.

1. Install two yokes (29 and 32) on both ends of lower drive shaft (30) with two screws (26), slotted nuts (27), and new cotter pins (28).
2. Position lower drive shaft (30) to vehicle.
3. Connect bottom yoke (29) to steering gear input shaft (31).
4. Install screw (26) and slotted nut (27) to yoke (29). Torque nut to 35 lb.ft. (47 N.m) and install new cotter pin (28).

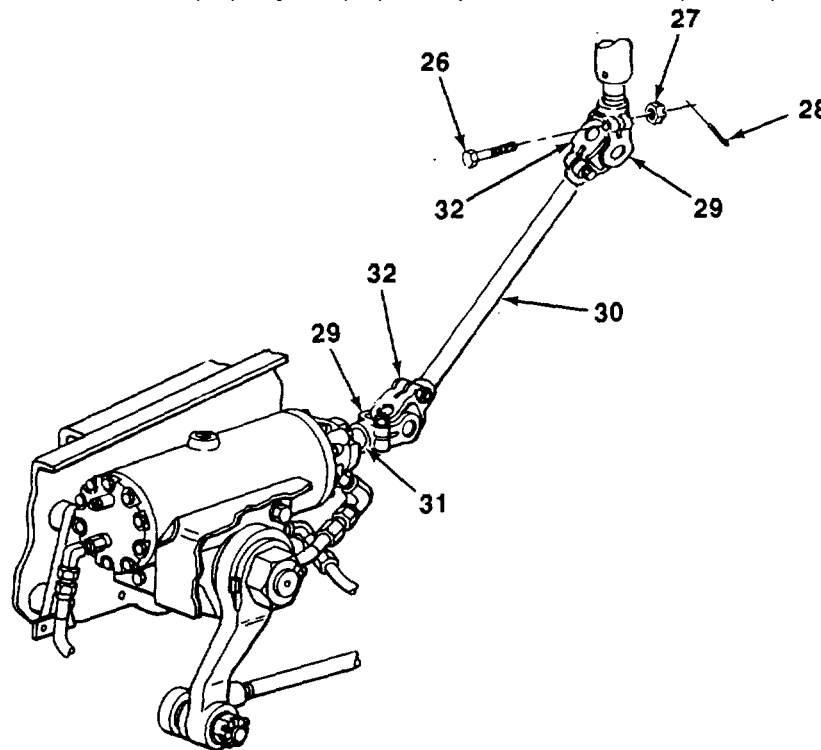

TA704046

12-6. STEERING COLUMN REPLACEMENT (Con't).

5. Position rubber boot (24) over end of drive shaft (15) and install rubber boot and retainer (23) with four screws (25) to firewall.

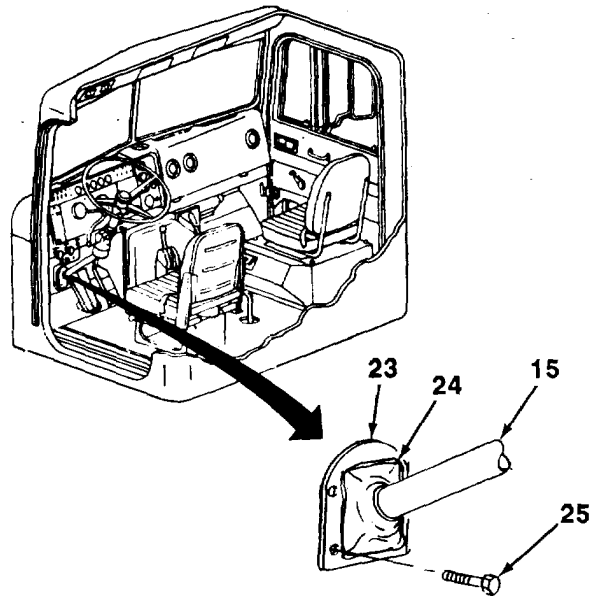

6. Install steering column brace (22) to firewall with two washers (21) and screws (20).

NOTE

Bottom-left hole of steering column bracket is used when installing turn signal switch.

7. Install steering column bracket (14) to instrument panel (19) with eight washers (17), three bolts (18), and nuts (16).

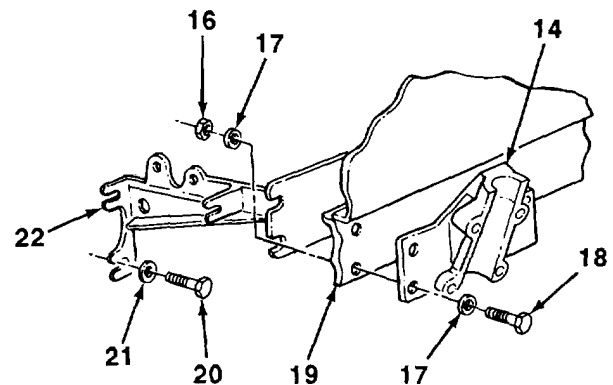

TA704047

12-6. STEERING COLUMN REPLACEMENT (Con't).

- 8. Install jacket tube (7) to drive shaft (15) and steering column bracket (14).
- 9. Install steering column cap (12) with four washers (11), two screws (13), and nuts (10).

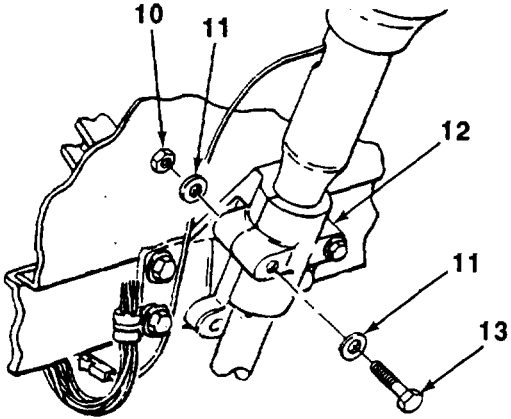
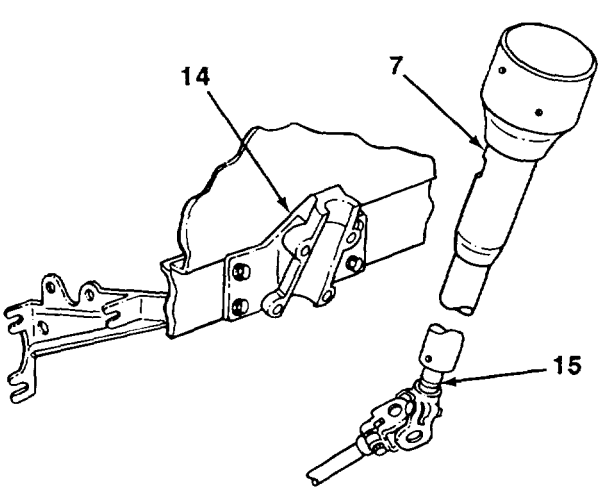

- 10. Install cover (9) over jacket tube (7) with four washers (6), two screws (8), and nuts (5).

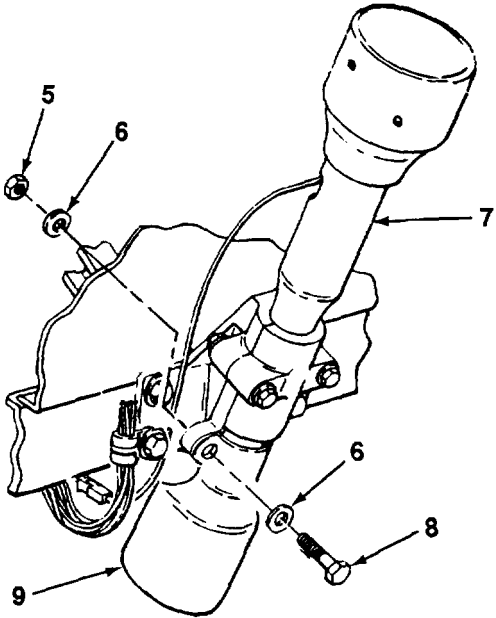

TA704048

12-6. STEERING COLUMN REPLACEMENT (Con't)

11. Connect lead and roller (3) to connector (4).
12. Replace nut (1) loosely on end of drive shaft (2).

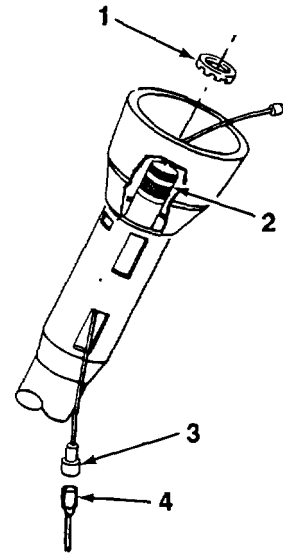
**FOLLOW-ON TASKS:**

- Install turn signal switch (see TM 5-3805-254-20).
- Install steering wheel (see paragraph 12-9).
- Close hood (see TM 5-3805-254-10).

TA704049

12-7. STEERING HYDRAULIC PUMP MAINTENANCE.

This Task Covers:

- | | |
|----------------------------|-----------------|
| a. Removal | d. Assembly |
| b. Disassembly | e. Installation |
| c. Cleaning and Inspection | |
-

Initial Setup:

Equipment Conditions:

- Hydraulic pump hoses and fittings removed (see TM 5-3805-254-20).

Tools/Test Equipment:

- General mechanic's tool kit
- Field automotive shop set

Materials/Parts:

- Lubricating oil (Item 13, Appendix B)
- Petrolatum (Item 16, Appendix B)
- Dry cleaning solvent (Item 23, Appendix B)
- One gasket
- Two lockwashers
- Two repair kits

References:

- TM 9-214

General Safety Instructions:

- Dry cleaning solvent is flammable and must not be used near open flame. Use only in a well-ventilated area.
-

a. REMOVAL

- Remove two screws (5) and lockwashers (4) from hydraulic pump (3). Discard lockwashers.
- Remove hydraulic pump (3), gasket (6), and coupling (2) from engine oil pump (1). Discard gasket.

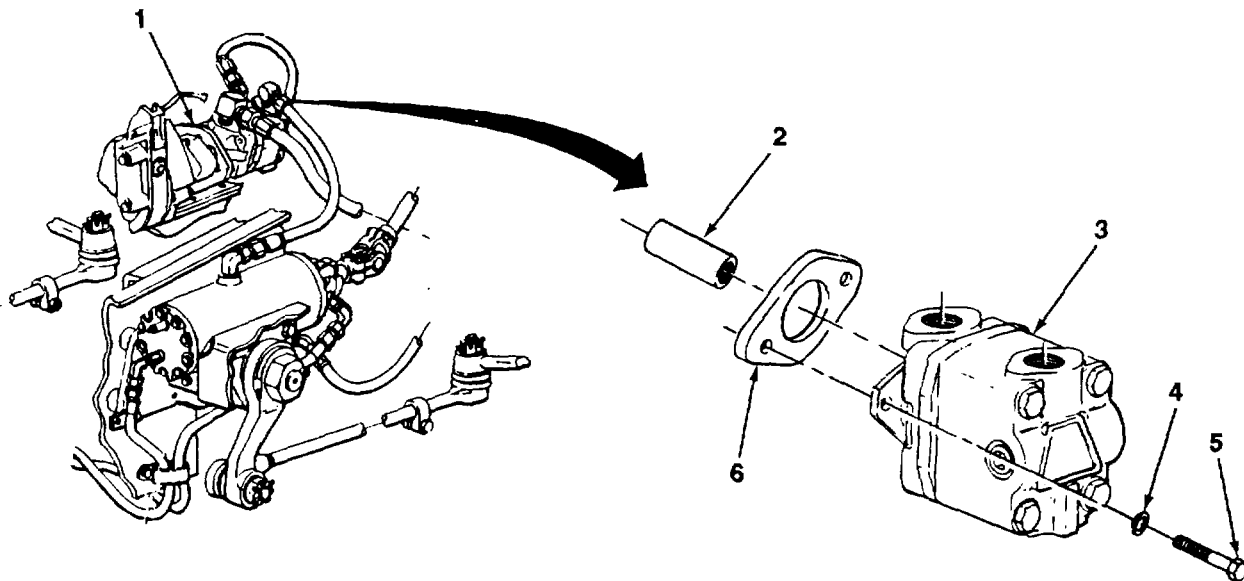

TA704050

12-7. STEERING HYDRAULIC PUMP MAINTENANCE (Con't).

b. DISASSEMBLY

1. Make alinement marks on pump body (11), housing (10), and pump cover (8) for assembly.
2. Remove four screws (7), pump cover (8), and seal (9). Discard seal.

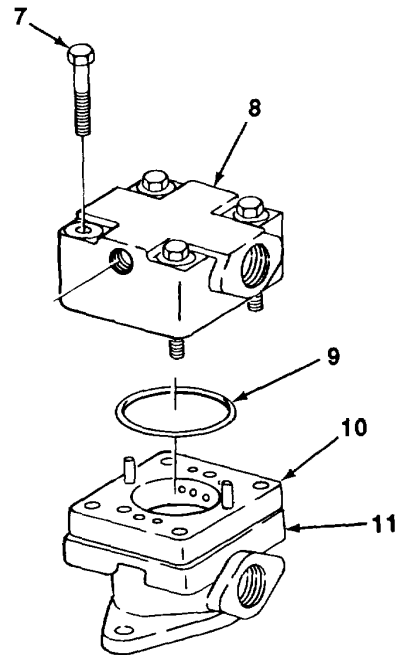

NOTE

Note position of valve in cover for assembly.

3. Remove plug (14), spring (13), and valve (12) from pump cover (8).
4. Remove plug (16) and snapping (15) from pump cover (8).

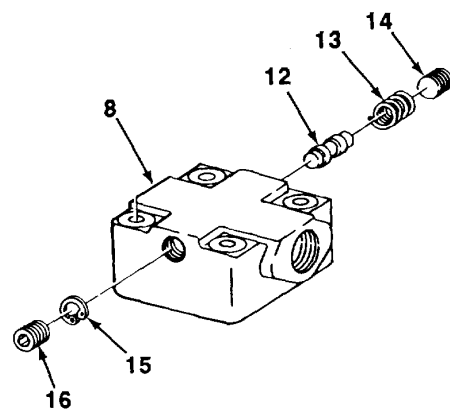

12-7. STEERING HYDRAULIC PUMP MAINTENANCE (Con't).

- 5. Remove spring (17) and pressure plate (18) from housing (10).
- 6. Remove and discard housing (10) and seal (19) from pump body (11).

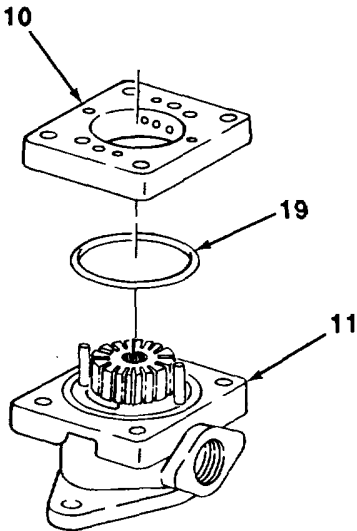
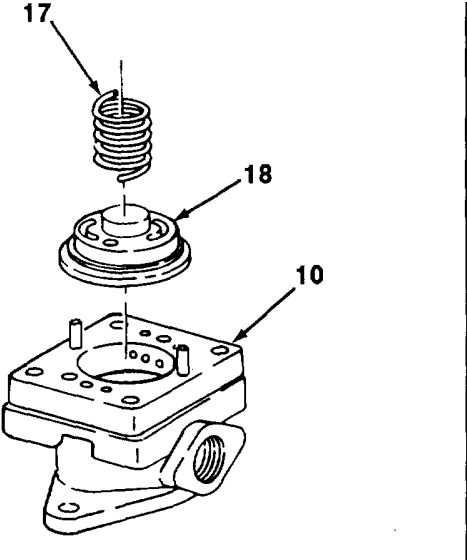

- 7. Remove and discard 12 vanes (20) and rotor (21) from rotor shaft (22).

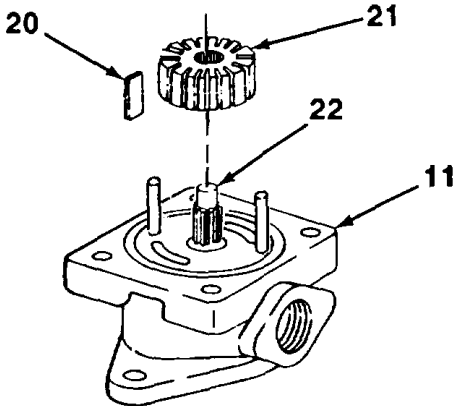

12-7. STEERING HYDRAULIC PUMP MAINTENANCE (Con't).

- 8. Remove snapping (23) from pump body (11).
- 9. Press rotor shaft (22) out from pump body (11).
- 10. While supporting inner race of bearing (24), press rotor shaft (22) out of bearing.

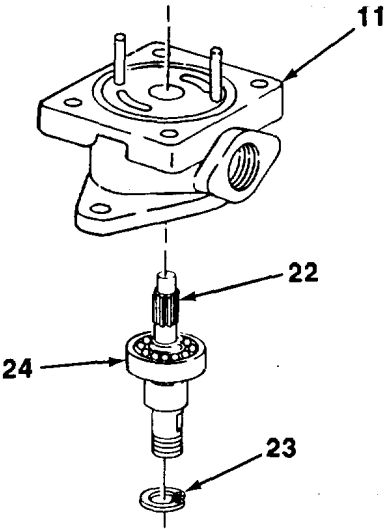

NOTE
Note position of shaft seal for assembly.

- 11. Using puller, remove shaft seal (25) from pump body (11). Discard shaft seal.
- 12. Press inner bearing (26) from pump body (11).

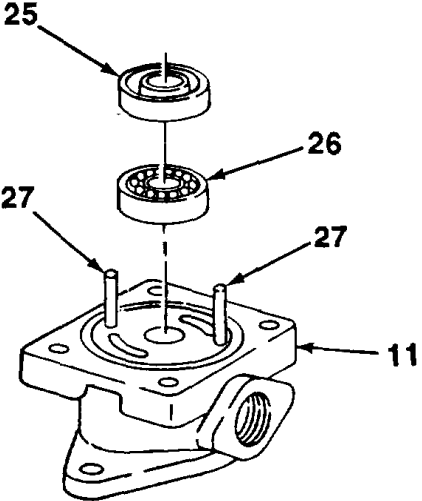

12-7. STEERING HYDRAULIC PUMP MAINTENANCE (Con't).

c. CLEANING AND INSPECTION

WARNING

Dry cleaning solvent, P-D-680, is toxic and flammable. Always wear protective goggles and gloves, and use only in a well-ventilated area. Avoid contact with skin, eyes, and clothes, and DO NOT breathe vapors. DO NOT use near open flame or excessive heat. The solvent's flash point is 100°F-1380F (38°C-590C). If you become dizzy while using cleaning solvent, immediately get fresh air and medical help. If solvent contacts eyes, immediately wash your eyes and get medical aid.

1. Clean metal parts with dry cleaning solvent.
2. Inspect metal parts for cracks, breaks, corrosion, or other damage. Replace damaged parts.
3. Inspect rotor shaft for scoring and wear. Replace if scored or worn.
4. Inspect bearings for wear or damage (see TM 9-214). Replace if worn or damaged.
5. Inspect two pins (27) in pump body (11). Replace if damaged.
6. Inspect bushing in pressure plate. Replace if worn or damaged.

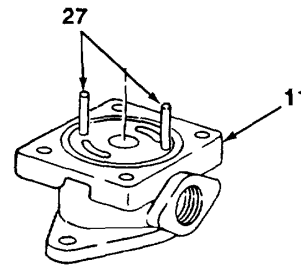

d. ASSEMBLY

1. Coat internal parts of hydraulic pump with oil. Use small amounts of petrolatum to hold seals in position for assembly.
2. Install snapping (15) and plug (16) in pump cover (8).
3. Install valve (12), spring (13), and plug (14) in pump cover (8).

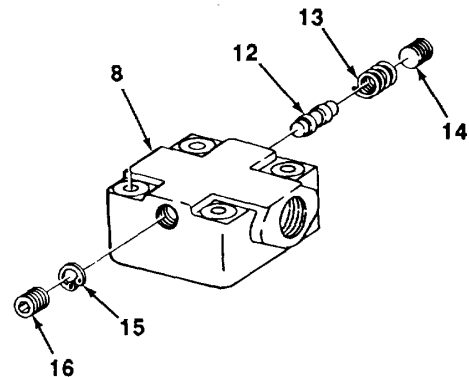

12-7. STEERING HYDRAULIC PUMP MAINTENANCE (Con't).**CAUTION**

Press on outside race to avoid damage to bearing. Ensure that bearing is fully seated in

4. Press Inner bearing (26) into pump body (11).
5. Press new shaft seal (25) into pump body (11).

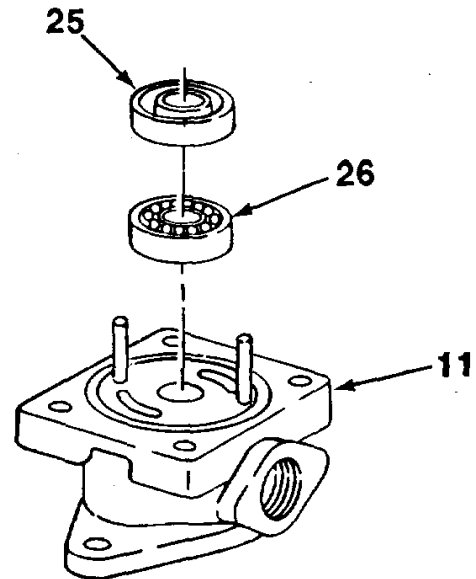
**CAUTION**

Support Inner race to avoid damage to bearing. Ensure that bearing is fully seated

6. Press rotor shaft (22) into Inner race of bearing (24).
7. Install rotor shaft (22) and bearing (24) into pump body (11).
8. Install snapping (23) into pump body (11).

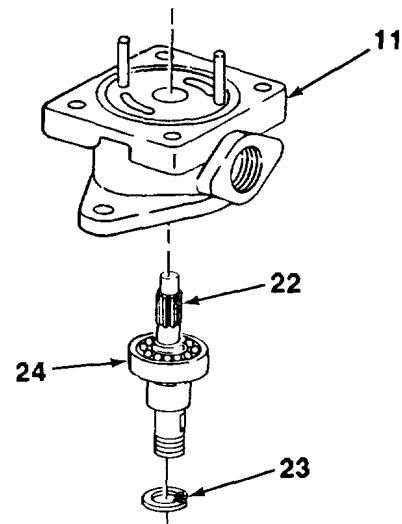

12-7. STEERING HYDRAULIC PUMP MAINTEN

- 9. Install new seal (19) and new housing (10) to pump body (11).

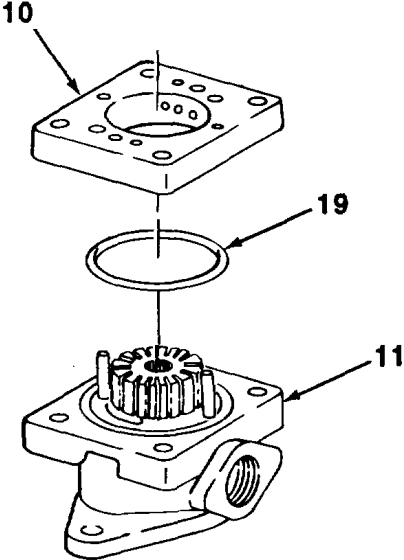

- 10. Install new rotor (21) and 12 new vanes (20) to rotor shaft (22).

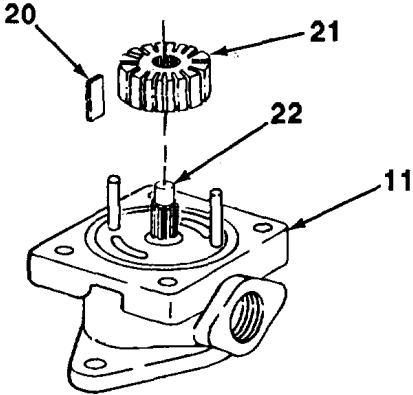

12-7. STEERING HYDRAULIC PUMP MAINTENANCE

11. Install pressure plate (18) and spring (17) to housing (10).

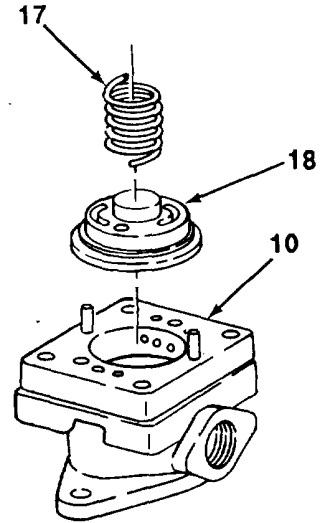

12. Install new seal (9) and pump cover (8) on housing (10) and pump body (11) with four screws (7). Torque screws to 70 lb.-ft. (95 N-m).

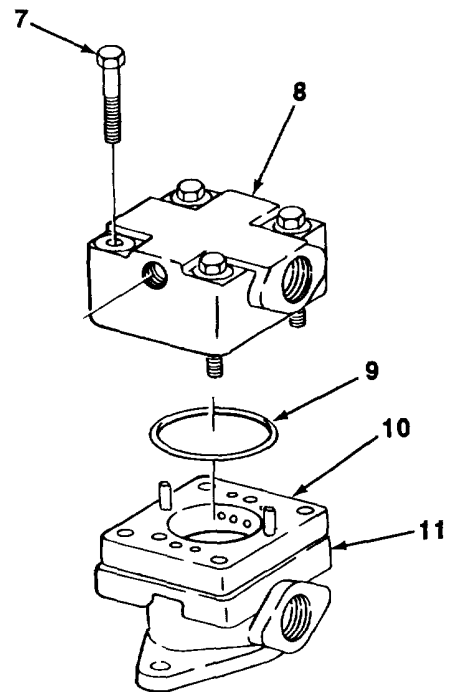

TA704057

12-7. STEERING HYDRAULIC PUMP MAINTENANCE (Con't)

e. INSTALLATION

1. Position coupling (2), new gasket (6), and hydraulic pump (3) to engine oil pump (1).
2. Install two new lockwashers (4) and screws (5).

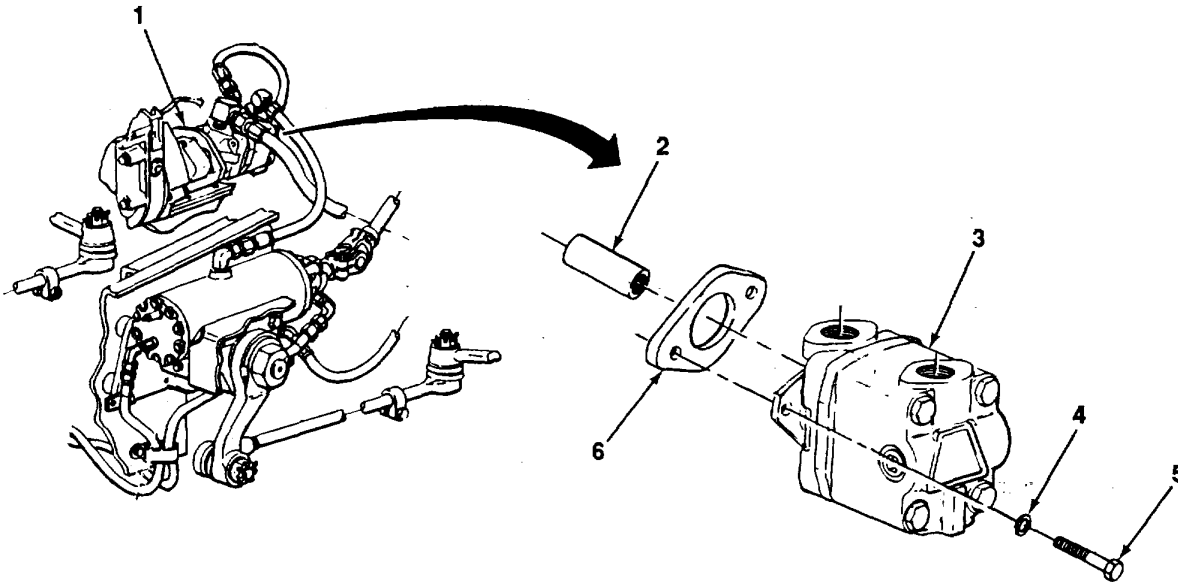
**FOLLOW-ON TASKS:**

- Install hydraulic pump hoses and fittings (see TM 5-3805-245-20).
- Fill power steering reservoir (see TM 5-3805-254-20).

TA704058

12-8. STEERING KNUCKLE MAINTENANCE

This Task Covers:

-
- | | |
|----------------------------|-----------------|
| a. Removal | d. Assembly |
| b. Disassembly | e. Installation |
| c. Cleaning and Inspection | |
-

Initial Setup:

Equipment Conditions:

- Front wheel removed (see TM 5-3805-254-20).
- Front hub, brakedrum, and wheel bearings removed (see TM 5-3805-254-20).
- Front brakeshoes removed (see TM 5-3805-254-20).
- Left front wheel to front brake limiting and quickrelease valve hoses removed (see TM 5-3805254-20) (left knuckle).
- Right front wheel to front brake limiting and quick-release valve hoses removed (see TM 5-3805254-20) (right knuckle).
- Front airbrake chambers removed (see TM 5-3805254-20).
- Front brake spider and dust shield removed (see paragraph 10-1).
- Tie-rod and drag link removed (see paragraphs 12-10 and 12-11).

Materials/Parts:

- Grease (Item 10, Appendix B)
- Dry cleaning solvent (Item 23, Appendix B)
- One repair kit
- Two cotter pins

Tools/Test Equipment:

- General mechanic's tool kit
- Field automotive shop set

Personnel Required: Two

General Safety Instructions:

- Dry cleaning solvent is flammable and must not be used near open flame. Use only in a well-ventilated area.

12-8. STEERING KNUCKLE MAINTENANCE (Con't).**a. REMOVAL****NOTE**

Perform the following steps for left or right steering knuckle.

1. Remove cotter pin (1), slotted nut (2), upper steering arm (4), and key (5) from steering knuckle (3). Discard cotter pin.
2. Remove cotter pin (9), slotted nut (8), (6), and key (7) from steering knuckle (3). Discard cotter pin.

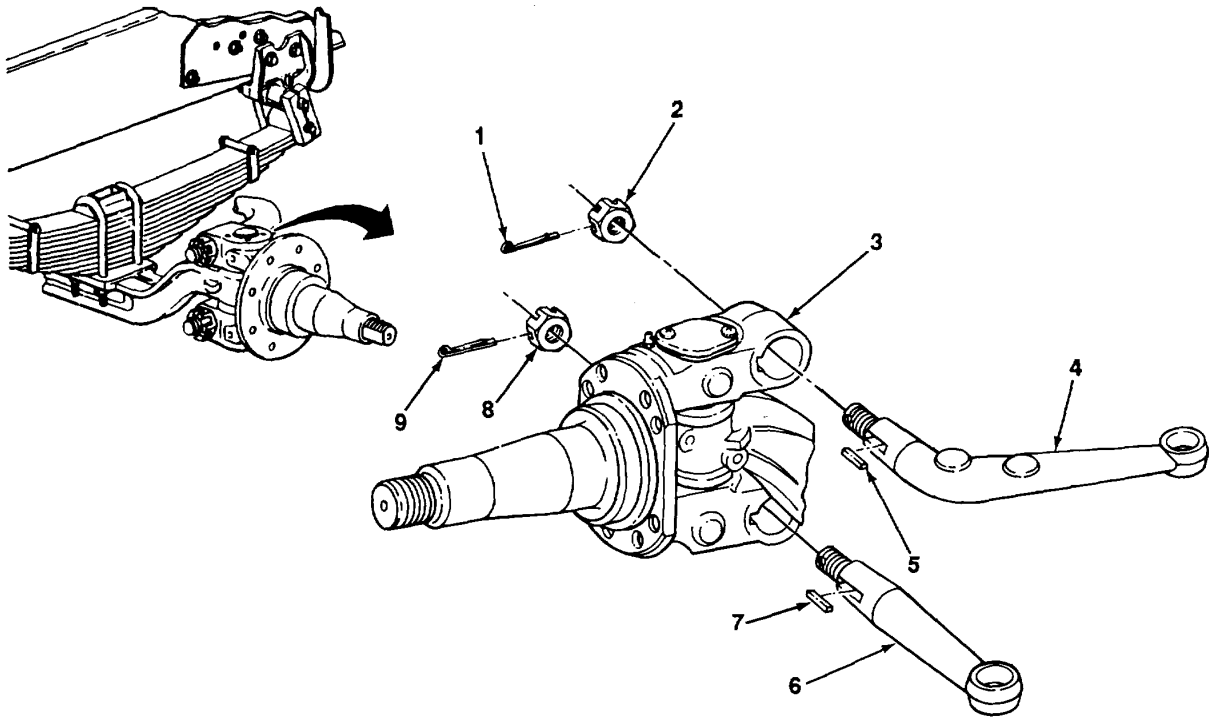

TA704059

12-8. STEERING KNUCKLE MAINTENAN(

- 3. Remove screw (10), lockwasher (11), cap (12), and gasket (13) from steering knuckle (3). Discard screw, lockwasher, cap, and gasket.
- 4. Remove snapping (14) and plug (15) from steering knuckle (3). Discard snapping and plug.

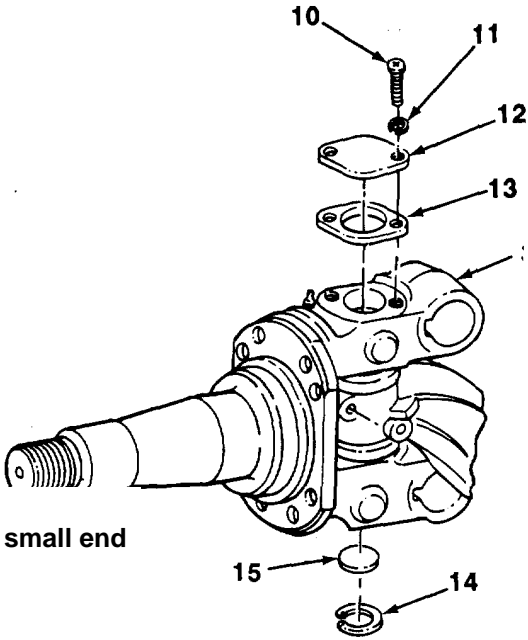

NOTE
Key is tapered. Drive key out from small end

- 5. Drive tapered key (16) out from end of axle (17).
- 6. Drive pin (18) downward and remove from steering knuckle (3). Discard pin.

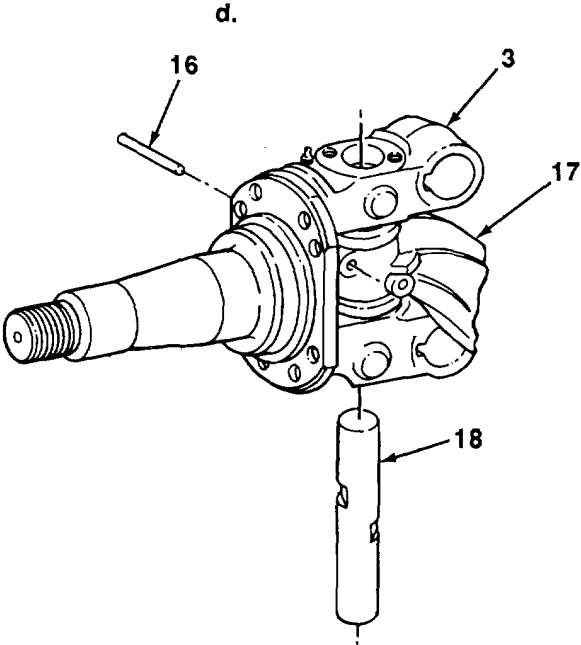

12-8. STEERING KNUCKLE MAINTENANCE (Con't).

7. Remove Steering knuckle (3), Shim(s) (19), and bearing (20) from front axle (17).

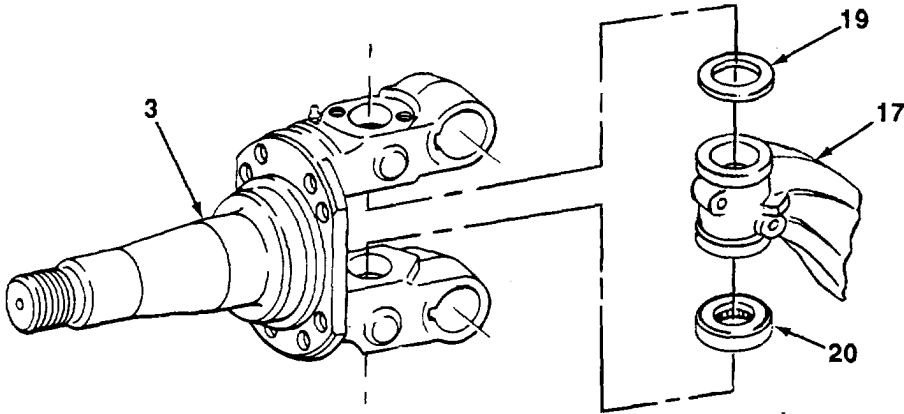

b. DISASSEMBLY

- 1. Remove two lubrication fittings (21 and 24) from steering knuckle (3).
- 2. Measure distance from end of steering stop screw (23) to stop surface of front axle for assembly
- 3. Loosen jamnut (22) and remove steering stop screw (23) and jamnut from steering knuckle

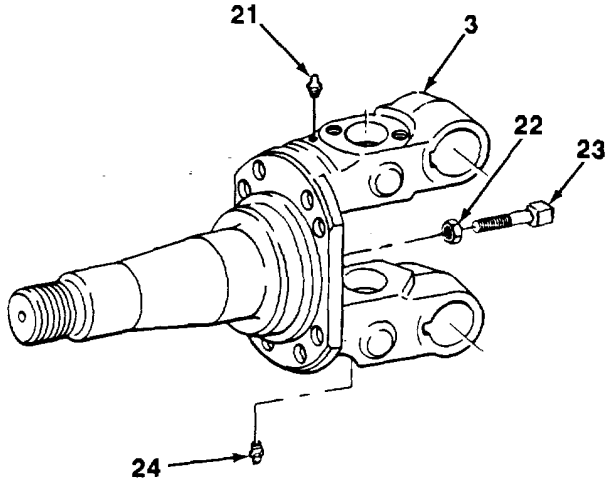

12-8. STEERING KNUCKLE MAINTENANCE (Con't).

4. Remove two bushings (25) from steering knuckle
- (3). Discard bushings.

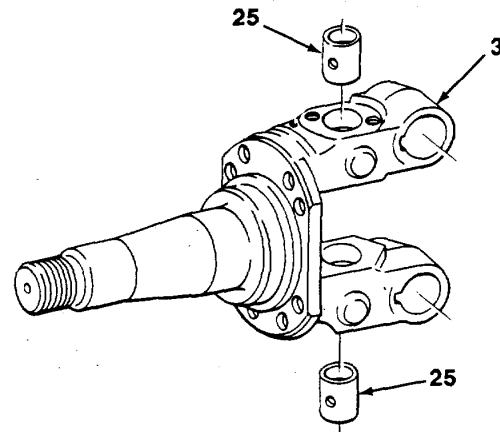
**c. CLEANING AND INSPECTION****WARNING**

Dry cleaning solvent, P-D-680, is toxic and flammable. Always wear protective goggles and gloves, and use only in a well-ventilated area. Avoid contact with skin, eyes, and clothes, and DO NOT breathe vapors. DO NOT use near open flame or excessive heat. The solvent's flash point is 1000F-138°F (380C-590C). If you become dizzy while using cleaning solvent, immediately get fresh air and medical help. If solvent contacts eyes, immediately wash your eyes and get medical aid.

1. Clean metal parts with dry cleaning solvent.
2. Inspect metal parts for cracks, breaks, corrosion, or other damage. Replace damaged parts.
3. Inspect bearing for wear or damage. Replace if worn or damaged.

TA704062

12-8. STEERING KNUCKLE MAINTENAN(

d. ASSEMBLY

- 1. Install two new bushings (25) in steering knuckle (3). Ream or hone diameter of bushings to 2.0015-2.0025 In. (5.0838-5.0864 cm).
- 2. Install jamnut (22) and steering stop screw (23) to steering knuckle (3). Tighten jamnut.
- 3. Install two lubrication fittings (21 and 24) to steering knuckle (3).

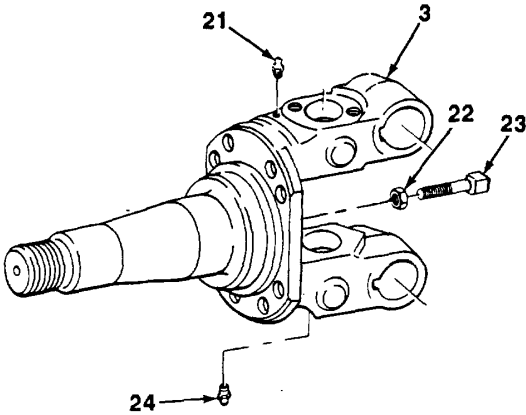
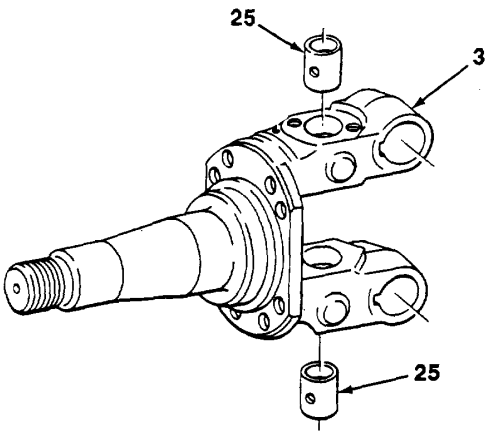

12-8. STEERING KNUCKLE MAINTENANCE (Con't).

e. INSTALLATION**NOTE**

Perform following steps for left or right steering knuckle.

1. Place bearing (20) and steering knuckle (3) into position on axle (17) and align holes.
2. Using hydraulic jack placed under steering knuckle (3), raise steering Knuckle upward.
3. Check clearance between top of axle (17) and steering knuckle (3). Clearance should be 0.015 in. (0.381 mm). Add shim(s) (19) in various thicknesses between top of axle and steering knuckle, as necessary, until proper clearance is obtained.

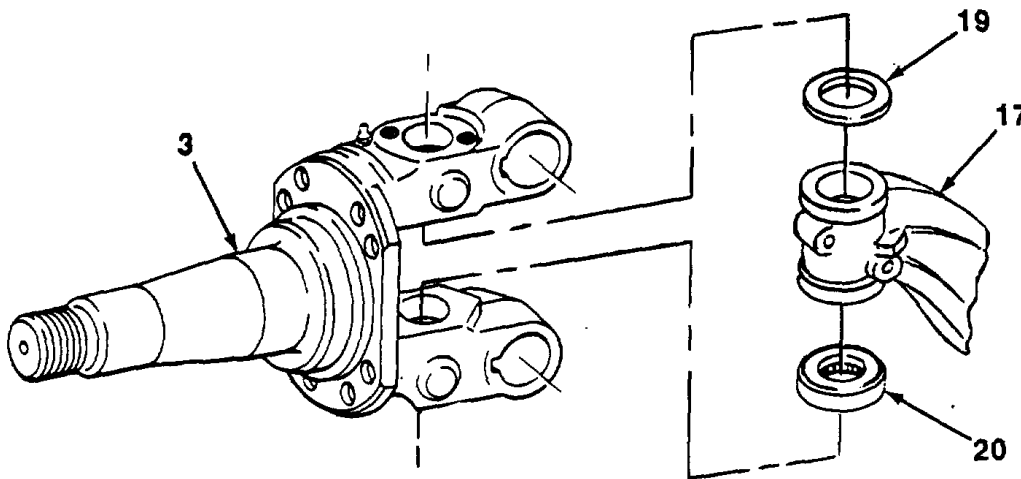

TA704064

12-8. STEERING KNUCKLE MAINTENANCE

4. Remove hydraulic jack.
5. Coat surface of new pin (18) with grease.

NOTE

Ensure that pin is positioned so that flat area will contact tapered key when key is installed in end of axle.

6. Press pin (18) into steering knuckle (3) and axle (17).
7. Install new plug (15) and new snapring (14) in bottom of steering knuckle (3).
8. Install new cap (12) and new gasket (13) to top of steering knuckle (3) with new lockwasher (11) and new screw (10).
9. Coat surface of tapered key (16) with grease and press into end of axle (17) until tightly seated.

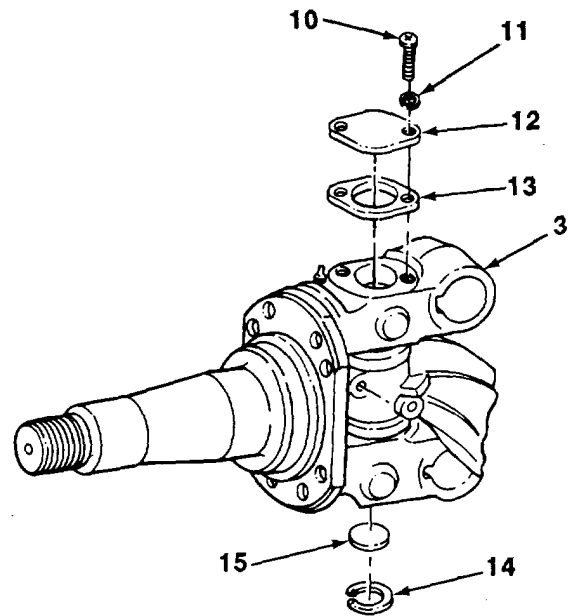
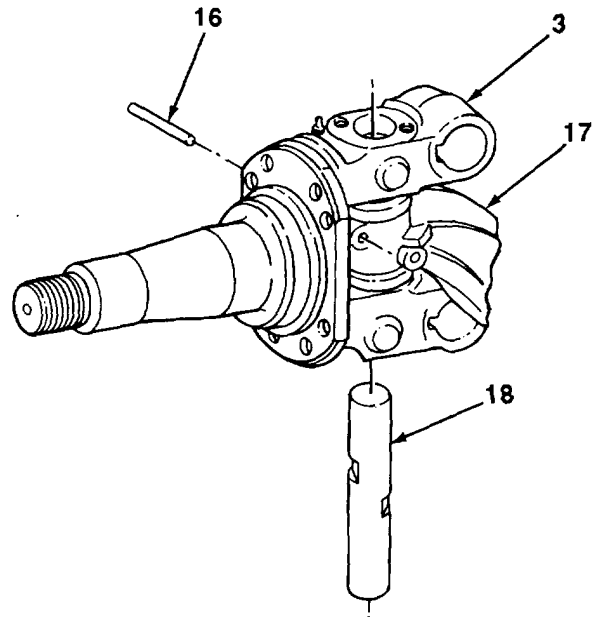

TA704065

12-8. STEERING KNUCKLE MAINTENANCE (Con't).

10. Install arm (6) and key (7) to steering knuckle (3) with slotted nut (8). Torque slotted nut to 400 lb.-ft. (542 N-m) and install new cotter pin (9).
11. Install upper steering arm (4) and key (5) with slotted nut (2). Torque slotted nut to 400 lb.-ft. (542 N m) and install new cotter pin (1).

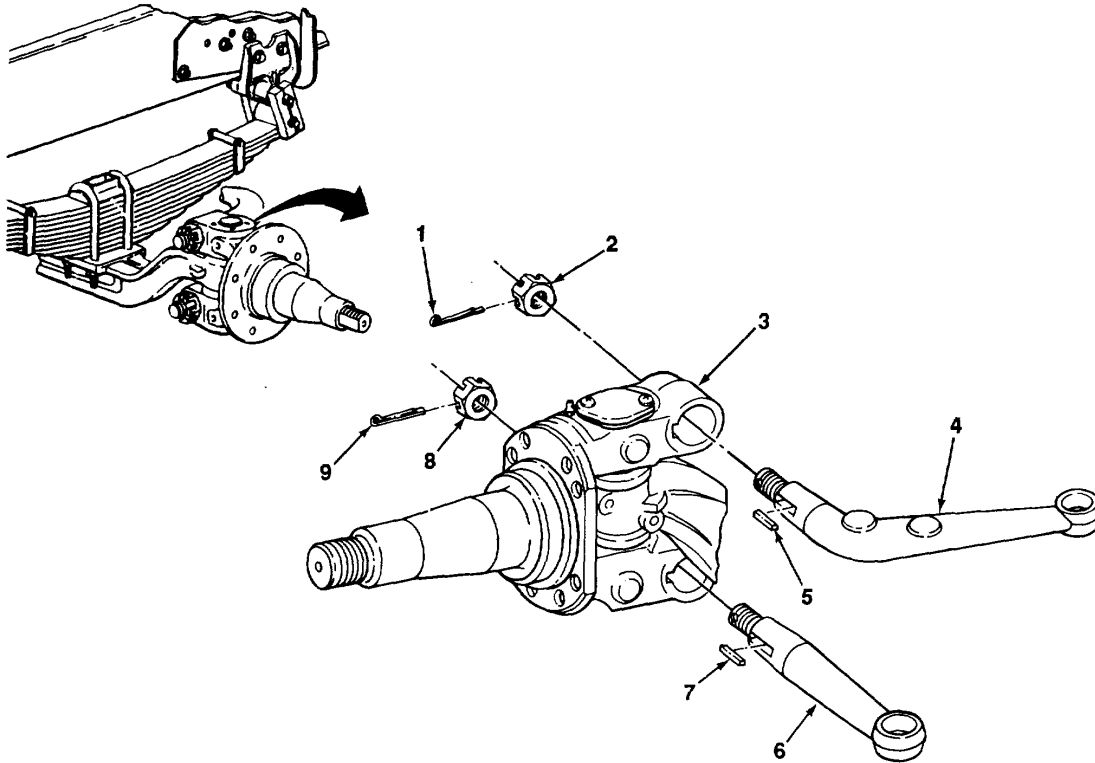
**FOLLOW-ON TASKS:**

- Install tie-rod and drag link (see paragraphs 12-10 and 12-11).
- Install front dust shield and brake spider (see paragraph 10-1).
- Install front airbrake chambers (see TM 5-3805-254-20).
- Install right front wheel to front brake limiting and quick-release valve hoses (see TM 5-3805-254-20) (right knuckle).
- Install left front wheel to front brake limiting and quick-release valve hoses (see TM 5-3805-254-20) (left knuckle).
- Install front brakeshoes (see TM 5-3805-254-20).
- Install hub, brakedrum, and wheel bearings (see TM 5-3805-254-20).
- Lubricate steering knuckle and steering system (see LO 5-3805-254-12).
- Install front wheel (see TM 5-3805-254-20).
- Aline wheels (see TM 3805-254-20).

TA704066

12-9. STEERING WHEEL REPLACEMENT.

This Task Covers:

- | | |
|-----------------|--------------|
| a. Removal | c. Alinement |
| b. Installation | |

Initial Setup:

Equipment Conditions:

- Horn button removed (see TM 5-3805-254-20)

Materials/Parts:

- Lithium grease (Item 11, Appendix B)

Tools/Test Equipment:

- General mechanic's tool kit
- Field automotive shop set

References:

- TM 5-3805-254-20

a. REMOVAL

1. Remove nut (2).

NOTE

Note alinement marks on steering wheel and steering shaft for assembly.

2. Using steering wheel puller, remove steering wheel (1) from steering shaft (4).
3. Remove two screws (5) and contact ring (3) from steering wheel (1).

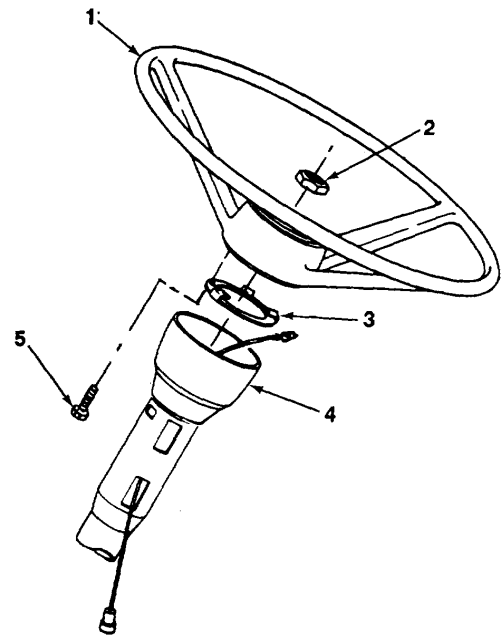

b. INSTALLATION

1. Install contact ring (3) to steering wheel (1) with two screws (5).
2. Apply thin film of lithium grease to surface of contact ring (3).

NOTE

Steering wheel must be installed on steering shaft with alinement marks alined. Do not attempt to center steering wheel with front wheel of vehicle by installing steering wheel in any other position on steering shaft.

3. Aline marks and install steering wheel (1) to steering shaft (4).
4. Install nut (2). Torque nut to 75-80 lb.-ft. (102-108 N m).
5. Install horn button (see TM 5-3805-254-20).

12-9. STEERING WHEEL REPLACEMENT (Con't).**c. ALINEMENT****NOTE**

- Perform these procedures to center steering wheel with front wheels of vehicle.
- Steering wheel must be installed on steering shaft with alignment marks aligned. Do not attempt to center steering wheel with frontwheels of vehicle by installing steering wheel in any other position on steering shaft.

1. Position front wheels of vehicle straight ahead.
2. Disconnect drag link (9) from steering arm (see paragraph 12-11).
3. Rotate steering wheel (1) until alignment mark (10) on end of steering gear output shaft (11) is perpendicular to steering gear input shaft (8).
4. Remove yoke (7) from steering gear input shaft (8) (see paragraph 12-6).
5. Rotate steering wheel until centered.

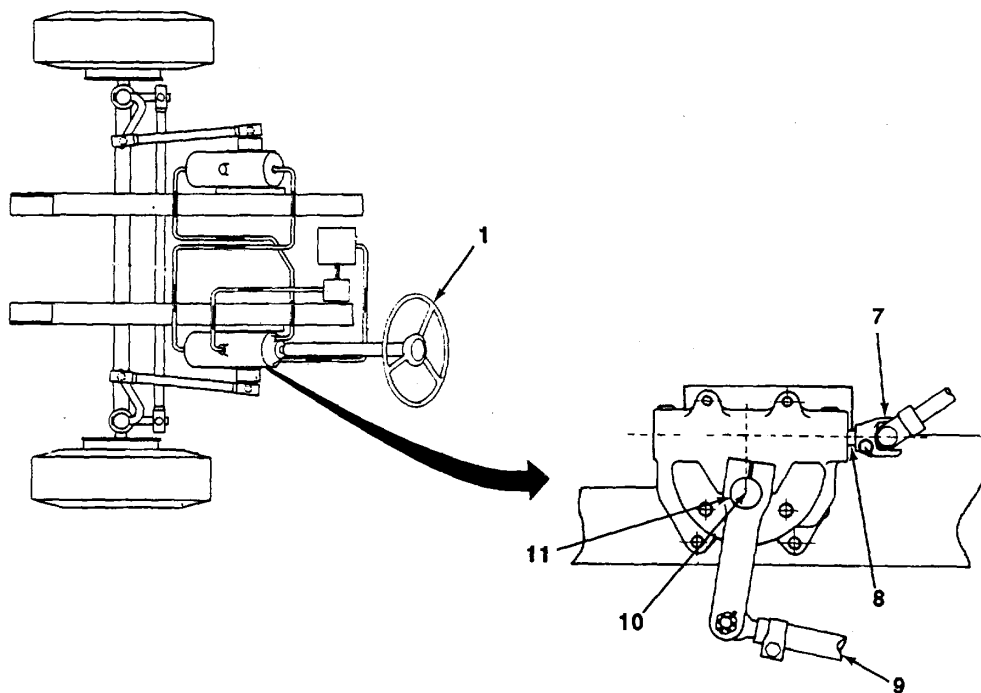

TA704068

12-9. STEERING WHEEL REPLACEMENT (Con't).

6. Install yoke (7) on steering gear input shaft (8) (see paragraph 12-6).
7. While keeping steering wheel (1) from rotating, adjust length of drag link (9) (see paragraph 12-1 1) to install drag link back on steering arm (6).
8. Test drive vehicle to ensure that steering wheel (1) is correctly alined with front wheels.

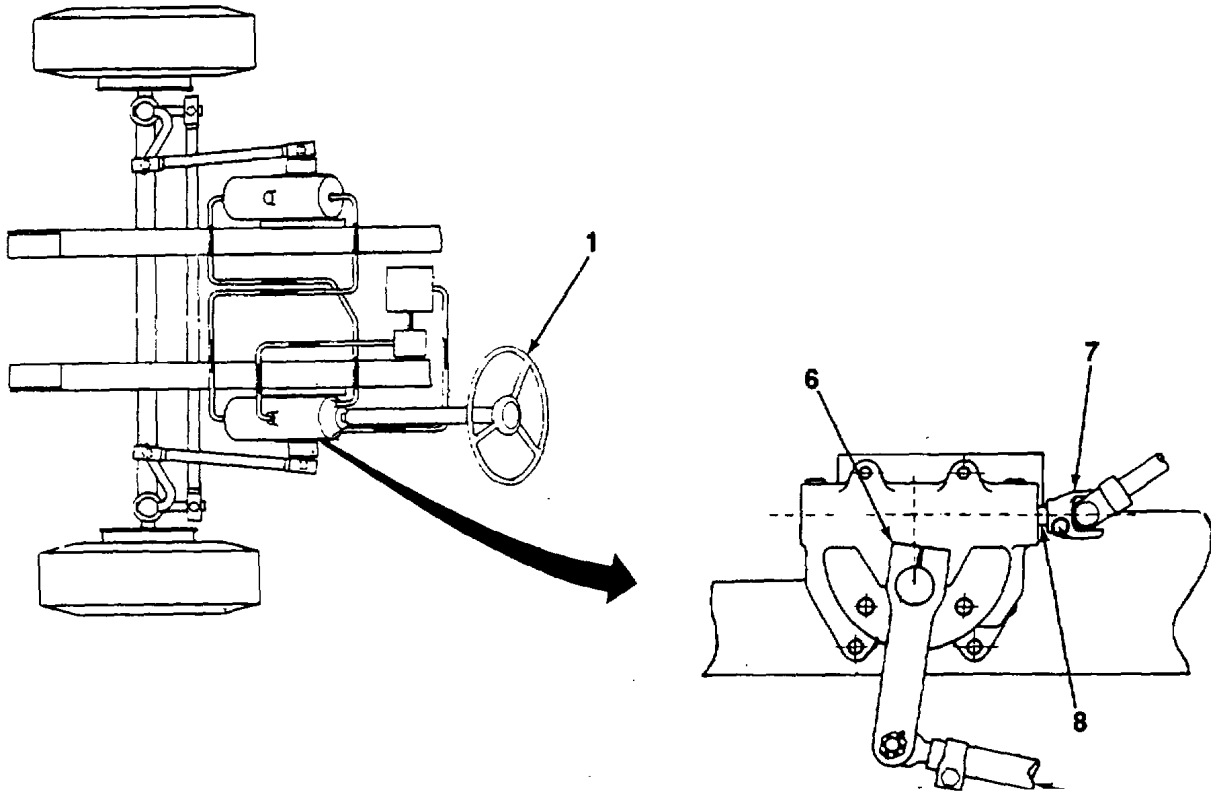

12-10. TIE-ROD MAINTENANCE.

This Task Covers:

- | | |
|----------------------------|-----------------|
| a. Removal | d. Assembly |
| b. Disassembly | e. Installation |
| c. Cleaning and inspection | |

Initial Setup:

Materials/Parts:

- Detergent (Item 5, Appendix B)
- Grease (Item 10, Appendix B)
- Dry cleaning solvent (Item 23, Appendix B)
- Two cotter pins
- Two lockwashers

Tools/Test Equipment:

- General mechanic's tool kit
- Field automotive shop set
- General Safety Instructions:
- Dry cleaning solvent is flammable and must not be used near open flame. Use only in a well-ventilated area.

a. REMOVAL**NOTE**

Both tie-rod ends are removed in the same manner. Left tie-rod end shown.

1. Remove cotter pin (2) and slotted nut (1) from tie-rod end (5). Discard cotter pin.

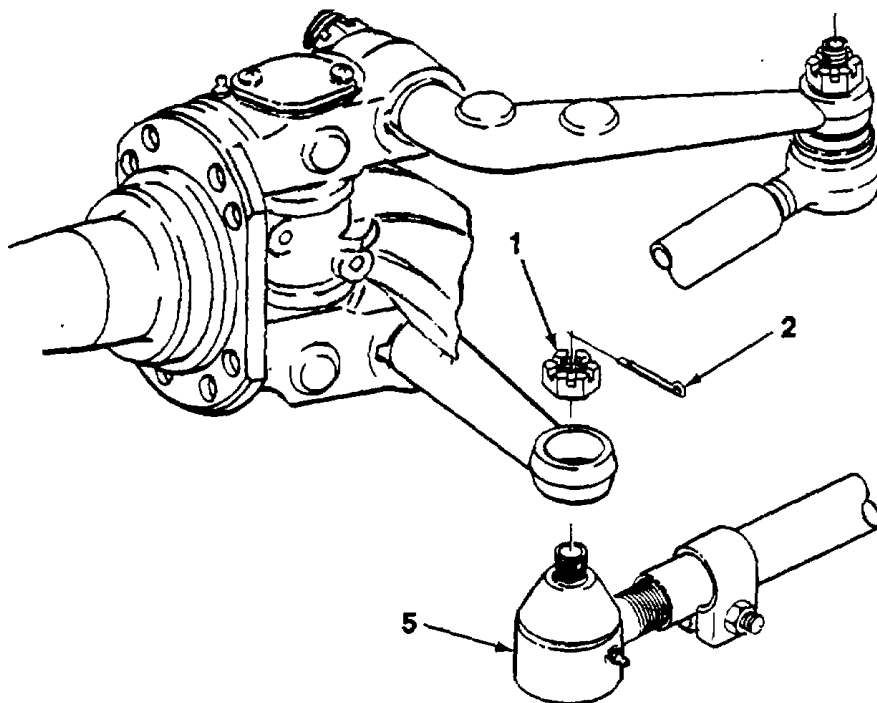

TA704070

12-10. TIE-ROD MAINTENANCE (Con't).

2. Repeat step 1 for other tie-rod end (5) on other side of tie-rod (3).
3. Remove tie-rod (3) from steering arm (6). MJ
4. Make alignment marks on tie-rod (3) and tie-rod ends (5) or measure overall length of tie-rod including tie-rod ends for assembly.

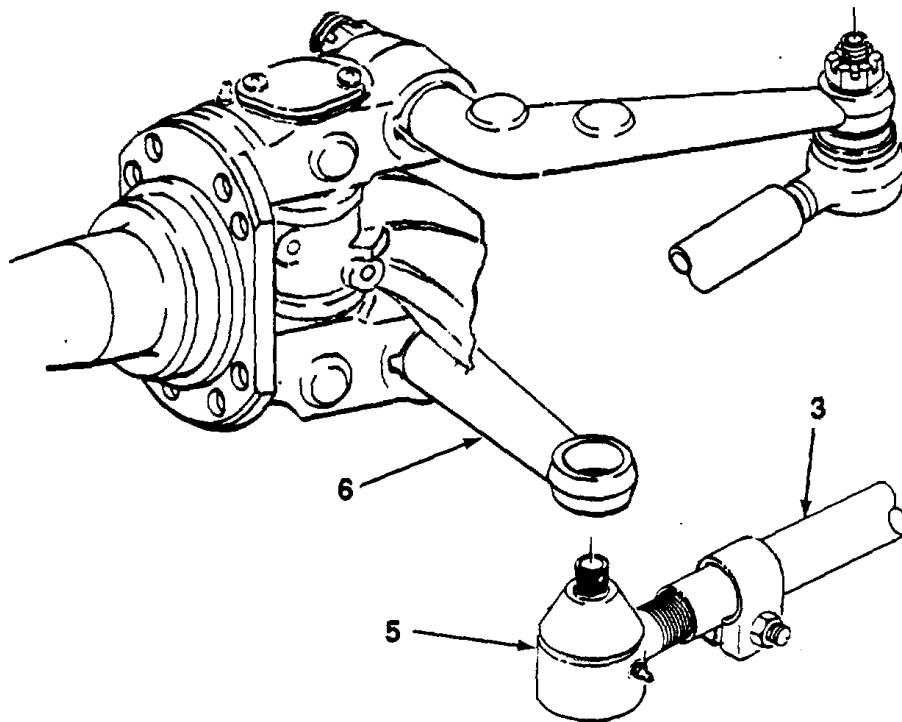

TA704071

12-10. TIE-ROD MAINTENANCE (Con't).**b. DISASSEMBLY**

1. Remove nut (4), lockwasher (10), and screw (7) from clamp (9) at each end of tie-rod (3). Discard lockwasher.
2. Remove dust cover (8) from tie-rod ends (5).

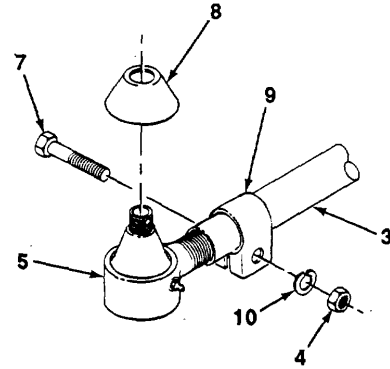

3. Remove tie-rod end (5) from each end of tie-rod (3).
4. Remove lubrication fitting (11) from tie-rod ends (5).

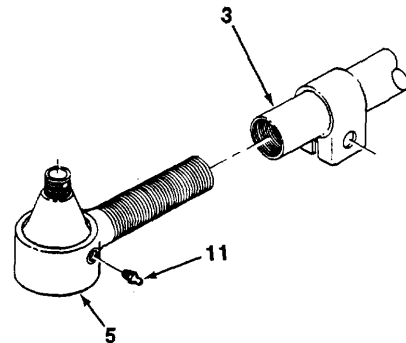

TA704072

12-10. TIE-ROD MAINTENANCE (Con't).

c. CLEANING AND INSPECTION
WARNING

Dry cleaning solvent, P-D-680, is toxic and flammable. Always wear protective goggles and gloves, and use only in a well-ventilated area. Avoid contact with skin, eyes, and clothes, and DO NOT breathe vapors. DO NOT use near open flame or excessive heat. The solvent's flash point is 100°F-1380F (380C-59°C). If you become dizzy while using cleaning solvent, immediately get fresh air and medical help. If solvent contacts eyes, immediately wash your eyes and get medical aid.

1. Clean metal parts with dry cleaning solvent.
2. Inspect metal parts for cracks, breaks, bends, corrosion, and other damage. Replace if damaged.
3. Clean rubber parts with detergent and water solution.
4. Inspect rubber parts for cracks, tears, and deterioration. Replace if damaged.

d. ASSEMBLY

1. Install lubrication fitting (11) to two tie-rod ends (5).

NOTE

One tie-rod end and one end of tie-rod has left-hand threads.

2. Install tie-rod ends (5) to tie-rod (3).
3. Install dust cover (8) to two tie-rod ends (5).
4. Loosely install screw (7), new lockwasher (10), and nut (4) to clamp (9) at each end of tie-rod (3).

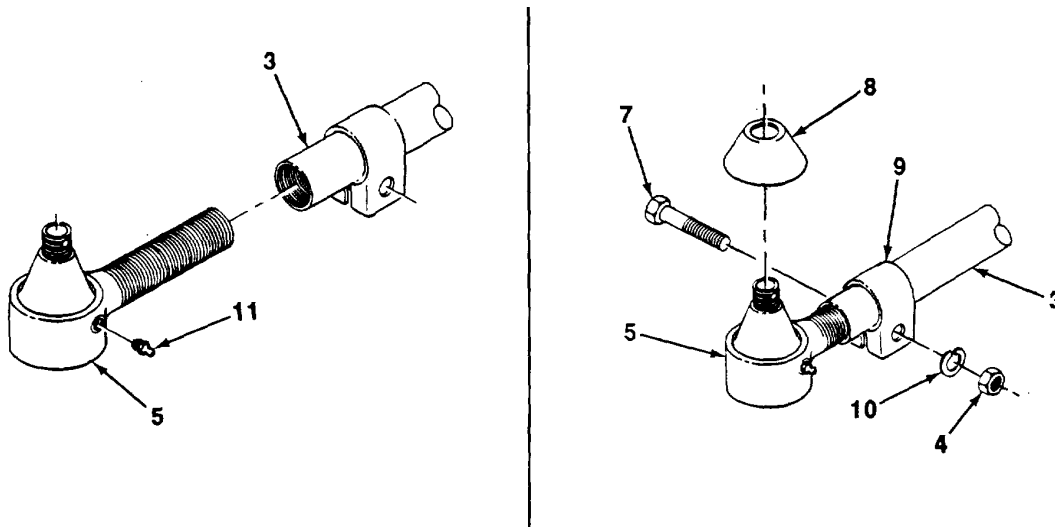

TA704073

12-10. TIE-ROD MAINTENANCE (Con't).

e. INSTALLATION

1. Position tie-rod ends (5) in steering arms (6), and install slotted nut (1) and new cotter pin (2) to tie-rod ends.
2. Tighten nuts (4).

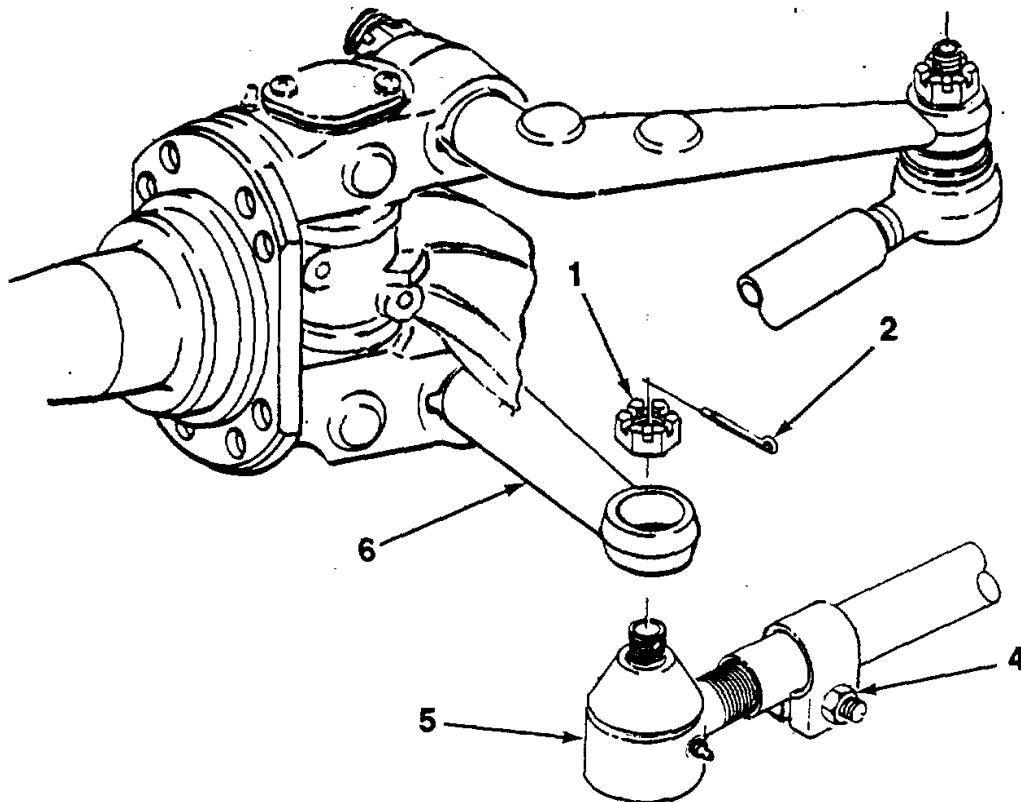
**FOLLOW-ON TASKS:**

- Lubricate tie-rod (see LO 5-3805-254-12).
- Aline wheels (see TM 5-3805-254-20).

TA704074

12-11. DRAG LINK MAINTENANCE.

This Task Covers:

- | | |
|----------------------------|-----------------|
| a. Removal | d. Assembly I |
| b. Disassembly | e. Installation |
| c. Cleaning and Inspection | |
-

*Initial Setup:***Equipment Conditions:**

- Steering arm removed (see paragraph 12-5).

Tools/Test Equipment:

- General mechanic's tool kit
- Field automotive shop set

General Safety Instructions:

- Dry cleaning solvent is flammable and must not be used near open flame. Use only in a well-ventilated area.
-

Materials/Parts:

- Detergent (Item 6, Appendix B)
- Grease (Item 10, Appendix B)
- Dry cleaning solvent (Item 23, Appendix B)
- One cotter pin
- Two lockwashers

a. REMOVAL**NOTE**

Perform the following steps for removing drag link at left or right side of vehicle.

1. Remove cotter pin (3) and slotted nut (2) from end link (4). Discard cotter pin.
2. Remove end link (4) from upper steering arm (1) of steering knuckle (7).
3. Make alignment marks on adjusting sleeve (6) and two end links (4) or measure overall length of end links and adjusting sleeve for assembly.

12-11. DRAG LINK MAINTENANCE (Con't).

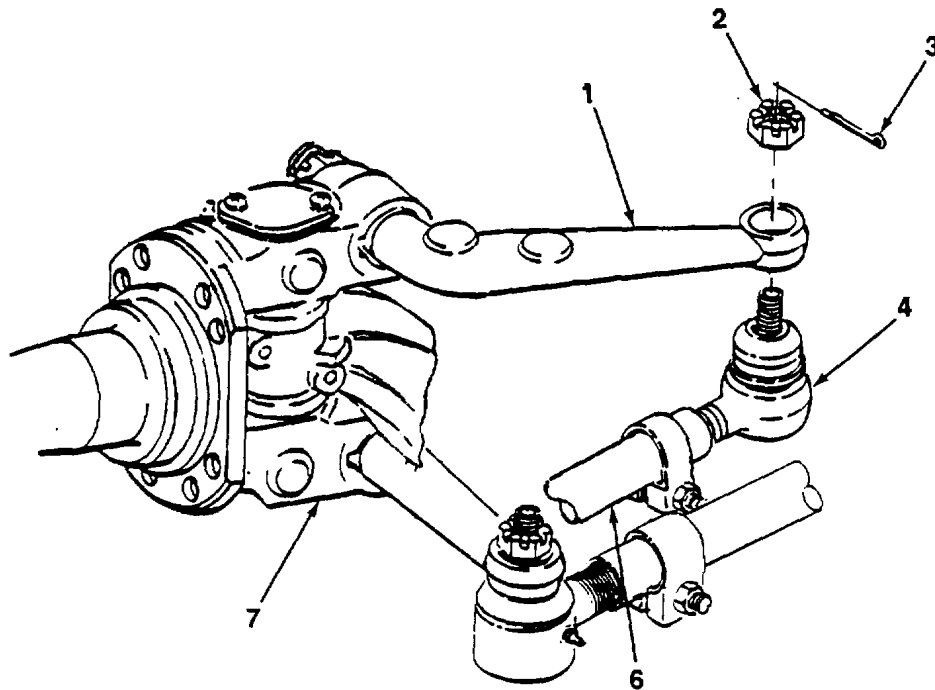

b. DISASSEMBLY

1. Remove nut (5), lockwasher (9), and screw (11) from clamp (10) at both ends of adjusting sleeve (6). Discard lockwasher.
2. Remove rubber cover (8) and end link (4) from both ends of adjusting sleeve (6).

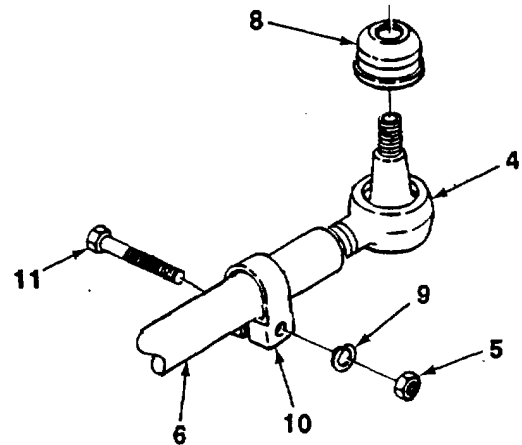

TA70475

12-11. DRAG LINK MAINTENANCE (Con't).

c. CLEANING AND INSPECTION**WARNING**

Dry cleaning solvent, P-D-680, is toxic and flammable. Always wear protective goggles and gloves, and use only in a well-ventilated area. Avoid contact with skin, eyes, and clothes, and DO NOT breathe vapors. DO NOT use near open flame or excessive heat. The solvent's flash point is 1000F-138°F (38°C-59°C). If you become dizzy while using cleaning solvent, immediately get fresh air and medical help. If solvent contacts eyes, immediately wash your eyes and get medical aid.

1. Clean metal parts with dry cleaning solvent.
2. Inspect metal parts for cracks, breaks, bends, corrosion, and other damage. Replace if damaged.
3. Clean rubber parts with detergent and water solution.
4. Inspect rubber parts for cracks, tears, and deterioration. Replace if damaged.

d. ASSEMBLY

1. Install rubber cover (8) and end link (4) to both ends of adjusting sleeve (6).
2. Loosely install screws (11), new lockwashers (9), and nuts (5) to clamps (10).

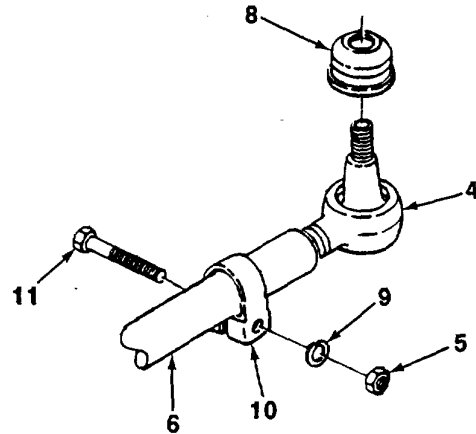

TA704076

12-11. DRAG LINK MAINTENANCE (Con't).

e. INSTALLATION**NOTE**

Perform the following steps for Installing drag link at left or right side of vehicle.

1. Coat tapered surface of end link (4) with thin film of grease.
2. Position end link (4) to upper steering -arm (1) of steering knuckle (7).
3. Install slotted nut (2) and new cotter pin (3) to end link (4).
4. Install steering arm (see paragraph 12-5).
5. Tighten nut (5).

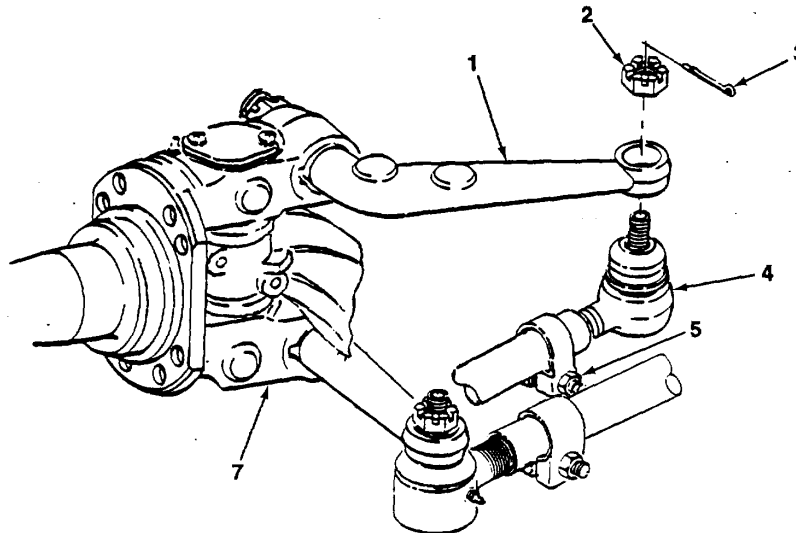
**FOLLOW-ON TASKS:**

- Align wheels (see TM 5-3805-254-20).

TA704077

**CHAPTER 13
SUSPENSION SYSTEM MAINTENANCE**

Paragraph Number	Paragraph Title	Page Number
13-1	Equalizer Beams Replacement.....	13-1
13-2	Front Springs Replacement	13-7
13-3	Rear Springs Replacement.....	13-13
13-4	Torque Rod Replacement.....	13-20

13-1. EQUALIZER BEAMS REPLACEMENT.

This Task Covers:

- | | |
|--|---|
| <ul style="list-style-type: none"> a. Removal b. Cleaning and Inspection | <ul style="list-style-type: none"> c. Installation |
|--|---|

Initial Setup:

Equipment Conditions:

- Rear wheels removed (see TM 5-3805-254-20).

Materials/Parts:

- Dry cleaning solvent (Item 23, Appendix B)
- Four cotter pins

Tools/Test Equipment:

- General mechanic's tool kit
- Field automotive shop set

General Safety Instructions:

- Dry cleaning solvent is flammable and must not be used near open flame. Use only in a well-ventilated area.

Personnel Required: Two

13-1. EQUALIZER BEAMS REPLACEMENT (Con't).**a. REMOVAL**

1. Remove four nuts (6) and two brackets (7) from equalizer beam (3) and saddle (8).
2. Remove four retainers (4) from two tubes (5).
3. Remove four cotter pins (1), two nuts (2), and tubes (5) from equalizer beam (3). Discard cotter pins.

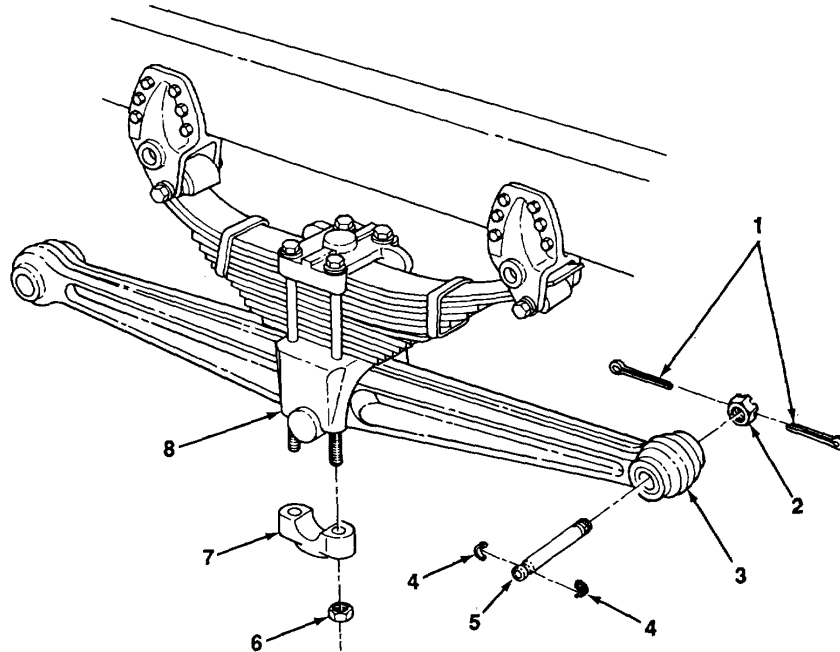

TA704078

13-1. EQUALIZER BEAMS REPLACEMENT (Con't).

- 4. Remove equalizer beam (3) and crosstube (9) from saddle (8).
- 5. Remove crosstube (9) from equalizer beam (3).

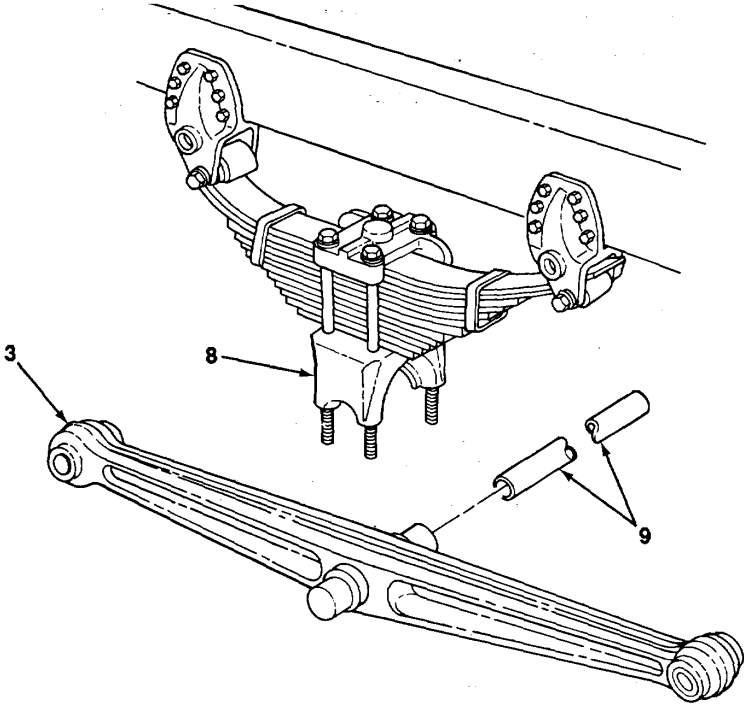

- 6. Remove two bushings (11) from equalizer beam (3).
- 7. Remove bushing (10) from equalizer beam (3).

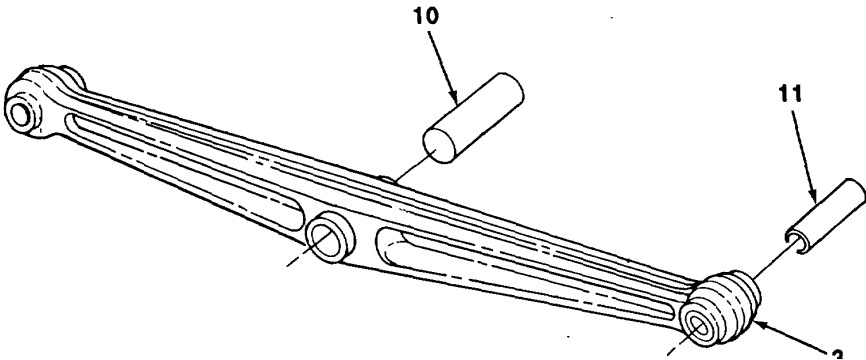

13-1. EQUALIZER BEAMS REPLACEMENT (Con't).

b. CLEANING AND INSPECTION**WARNING**

Dry cleaning solvent, P-D-680, is toxic and flammable. Always wear protective goggles and gloves, and use only in a well-ventilated area. Avoid contact with skin, eyes, and clothes, and DO NOT breathe vapors. DO NOT use near open flame or excessive heat. The solvent's flash point is 100°F-138°F (38°C-59°C). If you become dizzy while using cleaning solvent, immediately get fresh air and medical help. If solvent contacts eyes, immediately wash your eyes and get medical aid.

1. Clean metal parts with dry cleaning solvent.
2. Inspect metal parts for cracks, breaks, wear, corrosion, and other damage. Replace if damaged.

c. INSTALLATION

1. Install bushing (10) on equalizer beam (3).
2. Install two bushings (11) on equalizer beam (3).

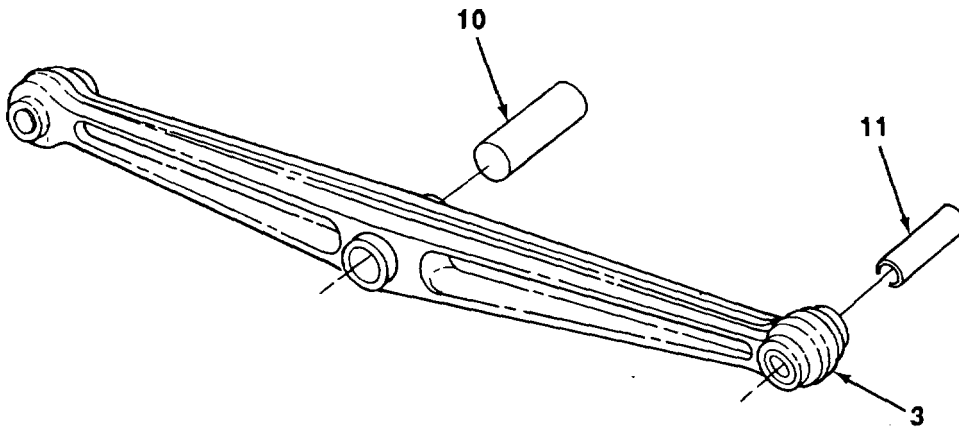

TA704080

13-1. EQUALIZER BEAMS REPLACEMENT (Con't).

- 3. Install crosstube (9) on equalizer beam (3).
- 4. Position equalizer beam (3) and crosstube (9) on saddle (8).

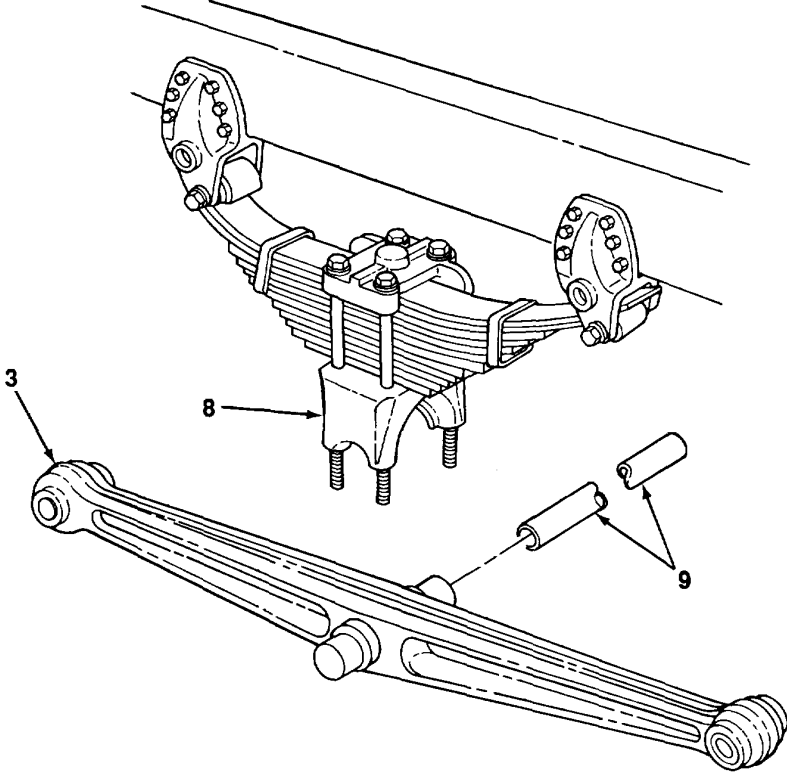

TA704081

13-1. EQUALIZER BEAMS REPLACEMENT (Con't).

5. Install two tubes (5) on equalizer beam (3).
6. Install four retainers (4) on two tubes (5) and install two nuts (2). Torque nuts to 450-500 lb.-ft. (610-678 N•m). Install four new cotter pins (1).
7. Install two brackets (7) on equalizer beam (3) and saddle (8) with four nuts (6). Torque nuts to 225-275 lb.-ft. (305-373 N•m)

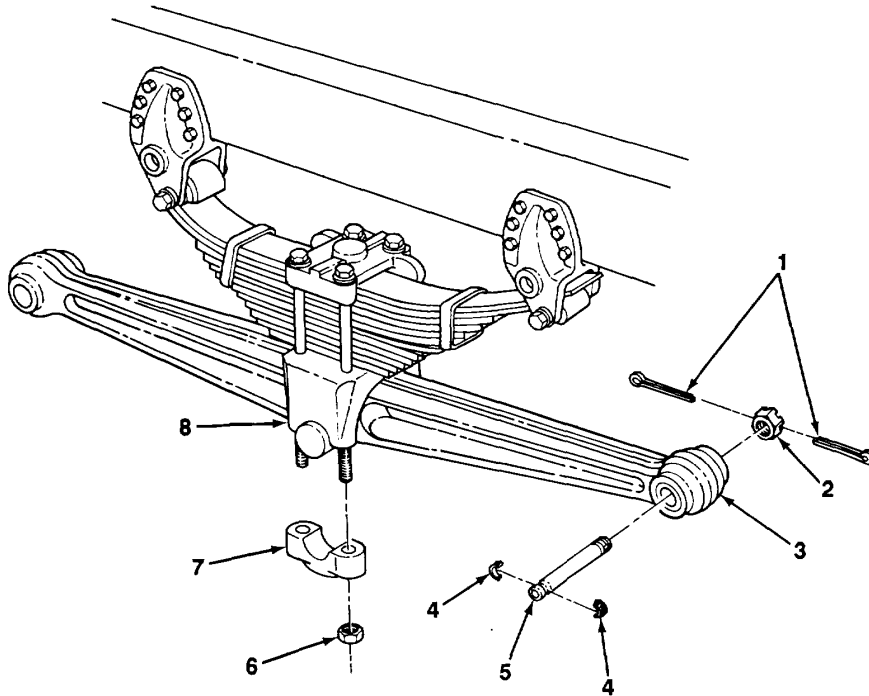
**FOLLOW-ON TASKS:**

- Install rear wheels (see TM 5-3805-254-20).

TA704082

13-2. FRONT SPRINGS REPLACEMENT.

This Task Covers:

- | | | | |
|----|-------------------------|----|--------------|
| a. | Removal | c. | Installation |
| b. | Cleaning and Inspection | | |

Initial Setup:

Equipment Conditions:

- Front axle removed (see paragraph 8-1).

Materials/Parts:

- Grease (Item 10, Appendix B)
- Dry cleaning solvent (Item 23, Appendix B)

Tools/Test Equipment:

- General mechanic's tool kit
- Field automotive shop set

General Safety Instructions

- Dry cleaning solvent is flammable and must not be used near open flame. Use only in a well-ventilated area.

Personnel Required: Two

a. REMOVAL**NOTE**

Perform the following steps for front spring at left or right side of vehicle.

1. Place hydraulic jack under center of front springs (7). Raise jack to support weight of front springs.
2. Remove two nuts (3), screws (5), and pin (6) to disconnect rear of front springs (7) from two shackles (4).

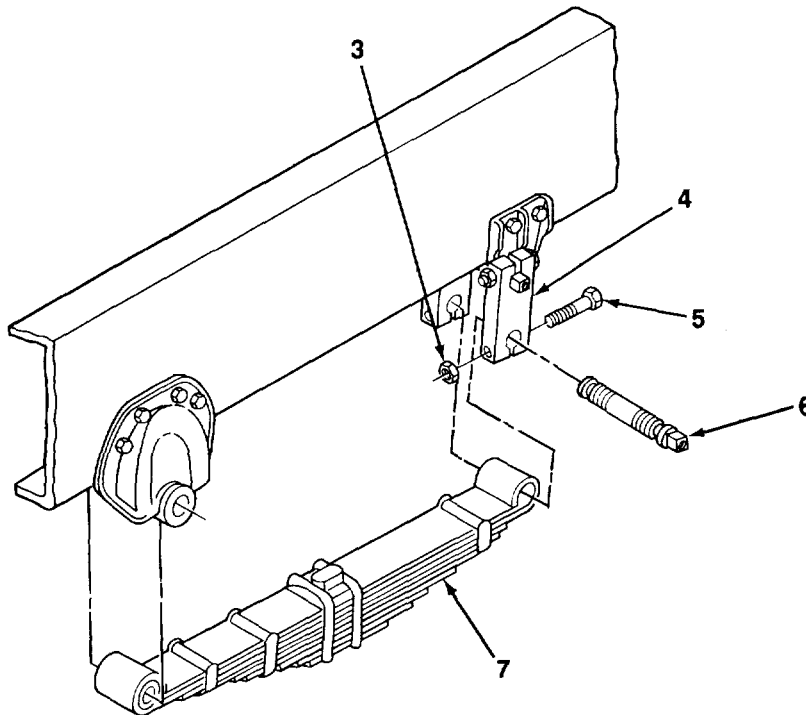

13-2. FRONT SPRINGS REPLACEMENT (Con't).

3. Remove nut (2), screw (8), and pin (1) from front bracket (9).

NOTE

Note position of front springs for assembly.

4. Lower hydraulic Jack and remove front springs (7) from vehicle.

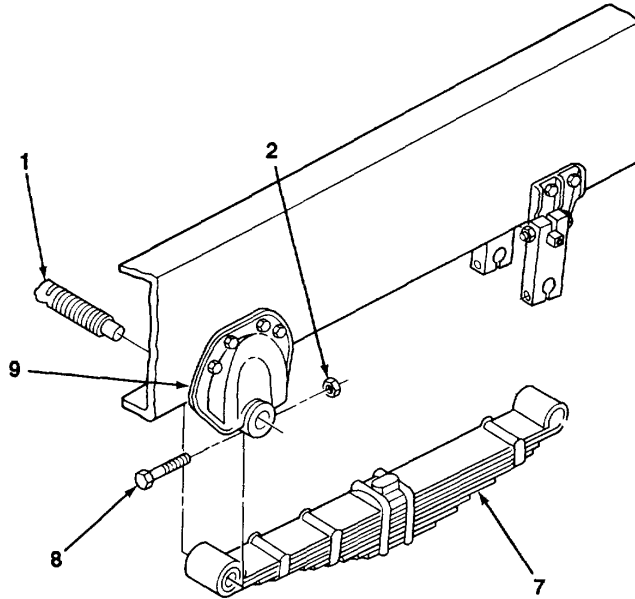
**NOTE**

Perform steps 5 and 6 to remove front brackets from frame.

5. Remove two nuts (20) and screws (22) from front bracket (9) and frame (21).
6. Remove four nuts (10), screws (19), and front bracket (9) from frame (21).

NOTE

Perform steps 7 through 9 to remove shackles and bracket from vehicle.

7. Remove two nuts (14), screws (16), pin (15), and two shackles (4) from bracket (12).
8. Remove two nuts (18) and screws (17) from bracket (12) and frame (21).
9. Remove two nuts (11), screws (13), and bracket (12) from frame (21).

TA704084

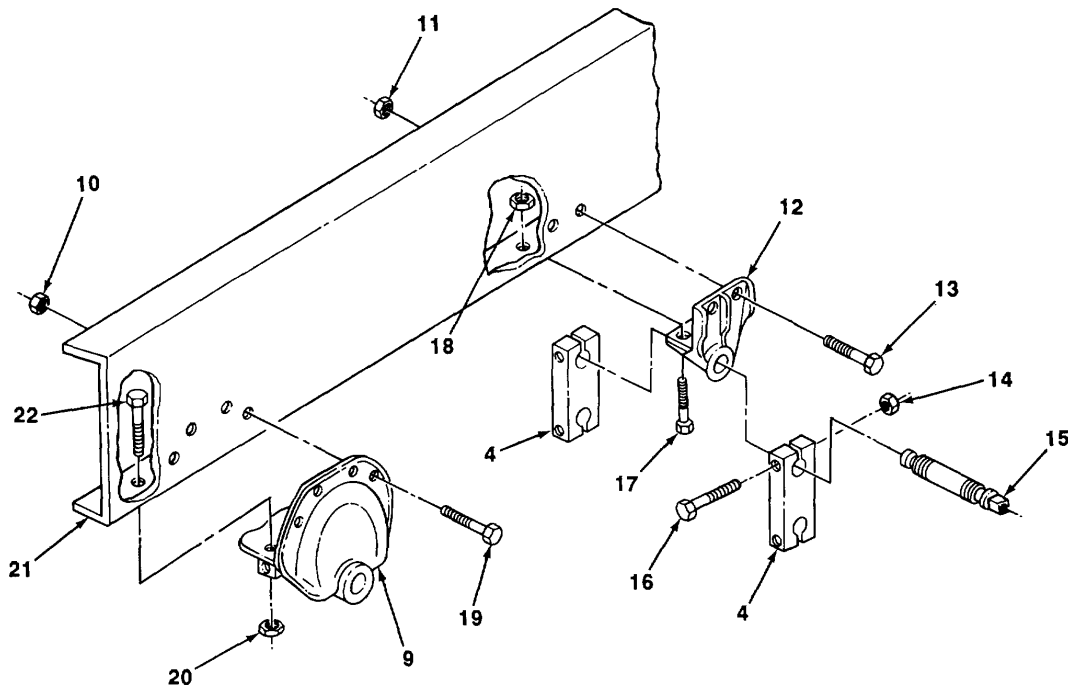
13-2. FRONT SPRINGS REPLACEMENT (Con't).**b. CLEANING AND INSPECTION****WARNING**

Dry cleaning solvent, P-D-680, is toxic and flammable. Always wear protective goggles and gloves, and use only in a well-ventilated area. Avoid contact with skin, eyes, and clothes, and DO NOT breathe vapors. DO NOT use near open flame or excessive heat. The solvent's flash point is 100°F-138°F (38°C-59°C). If you become dizzy while using cleaning solvent, immediately get fresh air and medical help. If solvent contacts eyes, immediately wash your eyes and get medical aid.

1. Clean metal parts with dry cleaning solvent.
2. Inspect metal parts for cracks, breaks, wear, corrosion, and other damage. Replace if damaged.
3. Inspect front spring leaves for cracks, breaks, and distortion. Replace front springs if damaged.

TA704085

13-2. FRONT SPRINGS REPLACEMENT (Con't)

4. Inspect three lubrication fittings (23, 24, and 25) in pins (1, 6, and 15) for damage. Replace damaged.

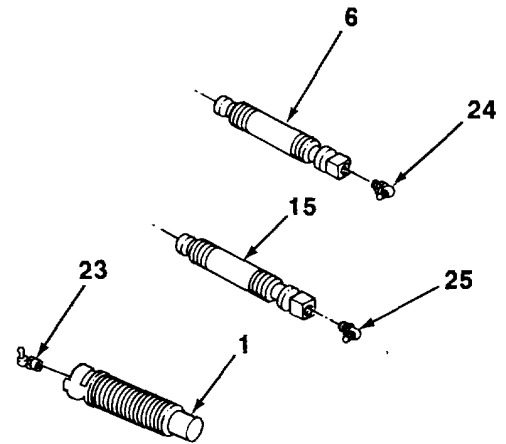
**c. INSTALLATION****NOTE**

Perform steps 1 through 4 to Install shackles and bracket to vehicle.

1. Install bracket (12) to frame (21) with two screws (13) and nuts (11).
2. Install two screws (17) and nuts (18) on bracket (12) and frame (21).
3. Coat surface of pin (15) with grease.
4. Install two shackles (4) to bracket (12) with pin (15), two screws (16), and nuts (14).

NOTE

Perform steps 5 and 6 to Install front bracket to vehicle.

5. Install front bracket (9) to frame (21) with four screws (19) and nuts (10).
6. Install two screws (22) and nuts (20) on front bracket (9) and frame (21).

TA704086

13-2. FRONT SPRINGS REPLACEMENT (Con't).

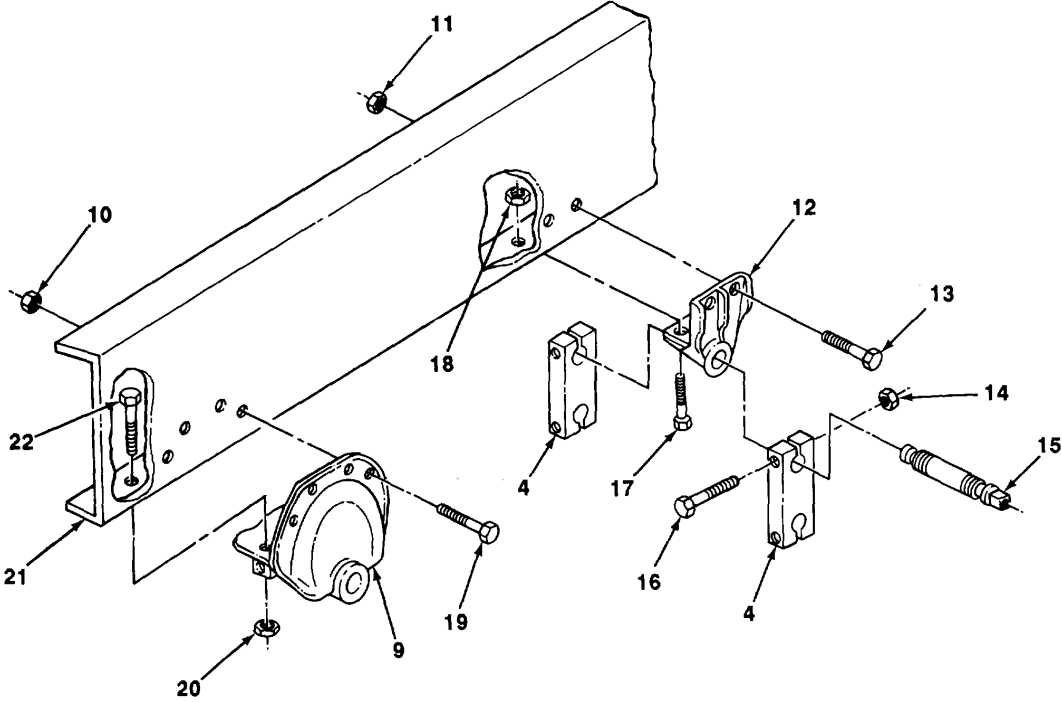

TA704087

13-2. FRONT SPRINGS REPLACEMENT (Con't).

7. Coat surface of pins (1 and 6) with grease.
8. Place front springs (7) on hydraulic jack and position on front bracket (9).
9. Install front springs (7) to front bracket (9) with pin (1), screw (8), and nut (2).
10. Install rear of front springs (7) to two shackles (4) with pin (6), two screws (5), and nuts (3).
11. Remove hydraulic jack.

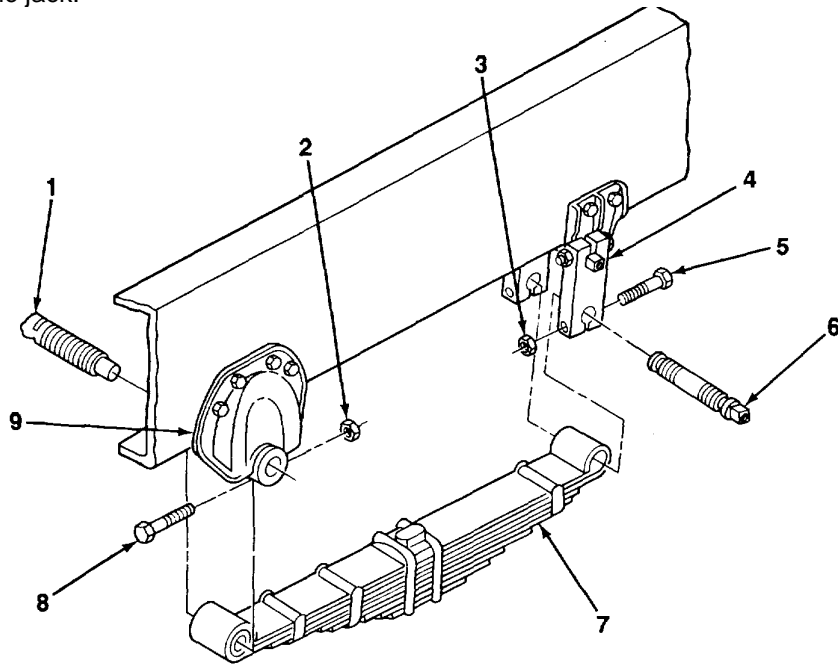
**FOLLOW-ON TASKS:**

- Lubricate front springs (see LO 5-3805-254-12).
- Install front axle (see paragraph 8-1).

TA704088

13-3. REAR SPRINGS REPLACEMENT.

This Task Covers:

- | | | | |
|----|-------------------------|----|--------------|
| a. | Removal | c. | Installation |
| b. | Cleaning and Inspection | | |

Initial Setup:

Materials/Parts:

- Dry cleaning solvent (Item 23, Appendix B)
- Five lockwashers

Tools/Test Equipment:

- General mechanic's tool kit
- Field automotive shop set

Personnel Required: Two

General Safety Instructions:

- Dry cleaning solvent is flammable and must not be used near open flame. Use only in a well-ventilated area.

a. REMOVAL

1. Place floor jack under truck frame and raise truck sufficiently to relieve weight from rear springs to be replaced.
2. Remove setscrew (6), nut (5), and lockwasher (4) from pad (3). Discard lockwasher.
3. Remove four nuts (11), screws (2), and pad (3) from rear springs (12) and saddle (10).
4. Remove two nuts (9), lockwashers (8), and keys (7) from brackets (1). Discard lockwashers.

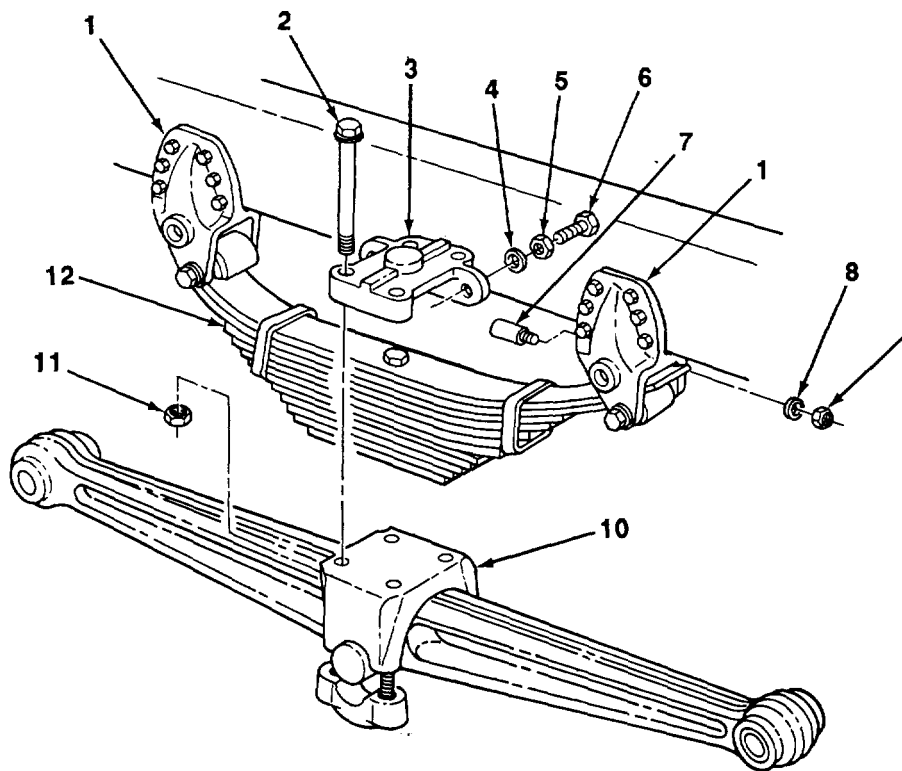

13-3. REAR SPRINGS REPLACEMENT (Con't).

5. Support rear springs (12) with jackstands.
6. Remove two nuts (19), lockwashers (18), pins (15), and spacers (17) from brackets (1) and rear springs (12). Discard lockwashers.
7. Remove two pins (13) and rollers (16) from brackets (1) and rear springs (12).
8. If damaged, remove lubrication fitting (14) from end of each pin (13).
9. Remove rear springs (12) from under truck

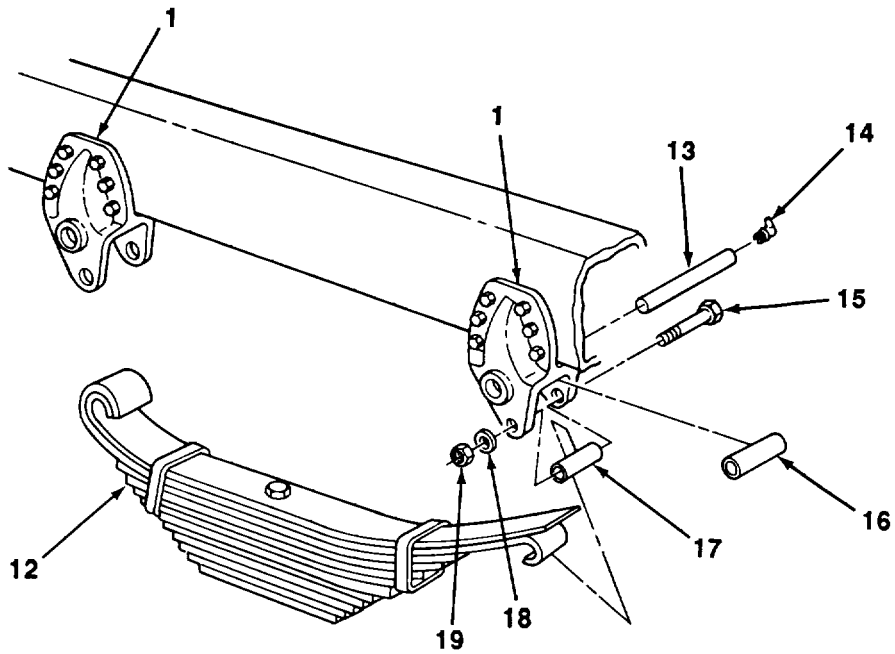

13-3. REAR SPRINGS REPLACEMENT (Con't).

NOTE

Perform steps 10 through 12 only if spring bracket is damaged.
Perform these steps for each spring bracket to be replaced.

- 10. Remove nut (27) and screw (26) from bracket (1).
- 11. Remove six nuts (24), screws (28), skid plate (23), bracket (1), and two spacer bars (25) from frame (20).
- 12. Remove four nuts (22), screws (29), plate (21), axle stop (30), and spacer bar (31) from frame (20).

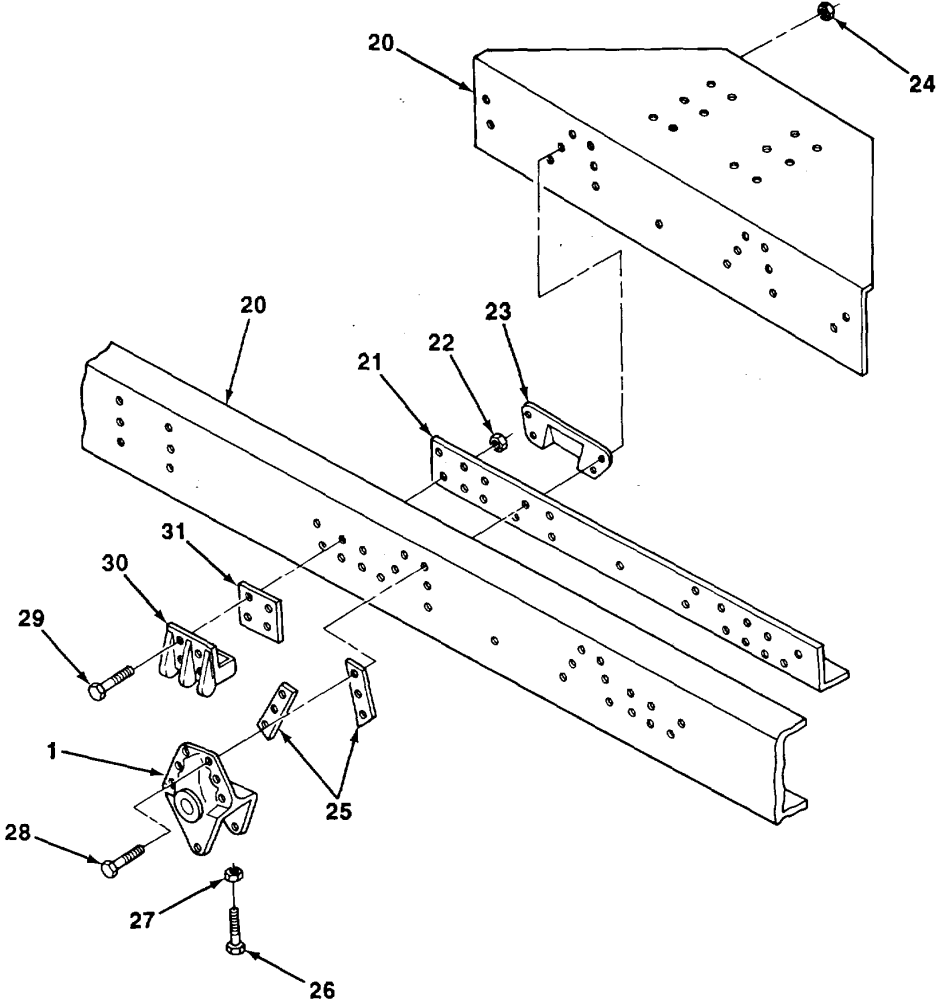

TA704091

13-3 REAR SPRINGS REPLACEMENT (Con't).

b. CLEANING AND INSPECTION**WARNING**

Dry cleaning solvent, P-D-680, is toxic and flammable. Always wear protective goggles and gloves, and use only in a well-ventilated area. Avoid contact with skin, eyes, and clothes, and DO NOT breathe vapors. DO NOT use near open flame or excessive heat. The solvent's flash point is 100°F-138°F (38°C-59°C). If you become dizzy while using cleaning solvent, immediately get fresh air and medical help. If solvent contacts eyes, immediately wash your eyes and get medical aid.

1. Clean metal parts with dry cleaning solvent.
2. Inspect metal parts for cracks, breaks, wear, corrosion, and other damage. Replace if damaged.
3. Inspect rear spring leaves for cracks, breaks, and distortion. Replace rear springs if damaged.

c. INSTALLATION**NOTE**

Perform steps 1 through 3 only if spring bracket was removed. Perform these steps for each spring bracket to be replaced.

1. Position plate (21) on frame (20) and install spacer bar (31) and axle stop (30) with four screws (29) and nuts (22).
2. Install skid plate (23), two spacer bars (25), and bracket (1) on frame (20) with six screws (28) and nuts (24).
3. Install screw (26) and nut (27) on bracket (1).

13-3. REAR SPRINGS REPLACEMENT (Con't).

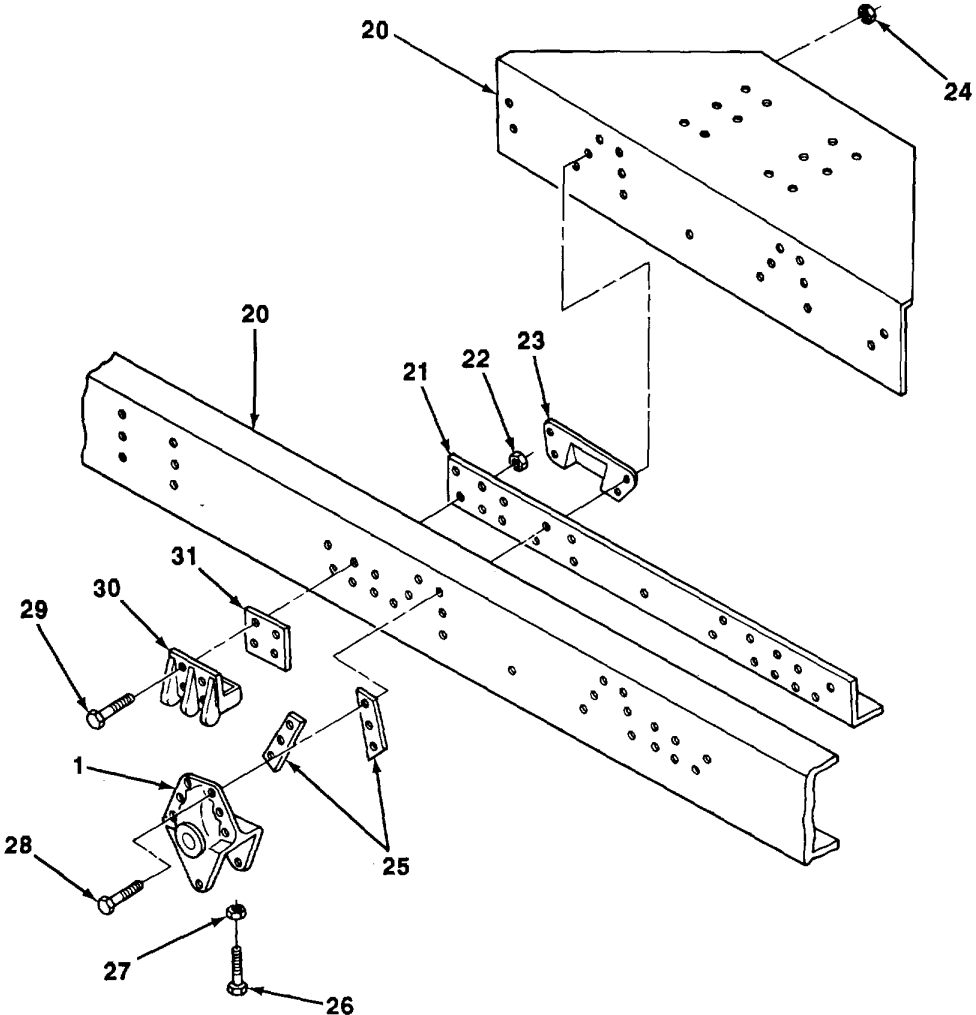

TA704092

13-3. REAR SPRINGS REPLACEMENT (Con't).

4. If removed, install lubrication fitting (14) on pin (13).
5. Position rear springs (12) on brackets (1) and install two rollers (16) and pins (13).
6. Install two spacers (17) and pins (15) on rear springs (12) and brackets (1) with two new lockwashers (18) and nuts (19). Torque nuts to 70-80 lb.-ft. (95-108 N•m).

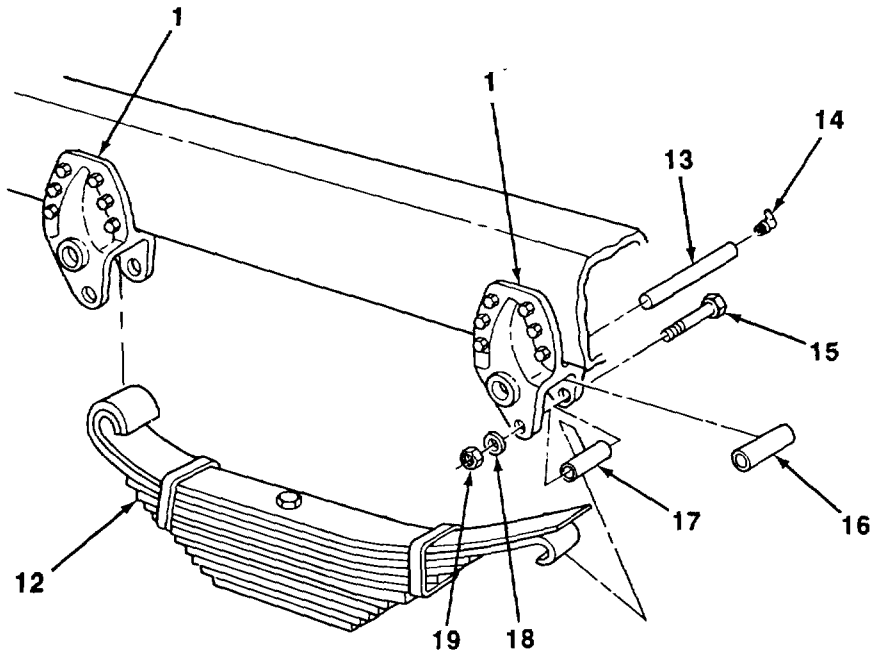

13-18

TA704093

13-3. REAR SPRINGS REPLACEMENT (Con't).

7. Install two keys (7), new lockwashers (8), and nuts (9) on brackets (1). Torque nuts to 80-90 lb.-ft. (108- 122 N•m).
8. Install pad (3) on rear springs (12) and saddle (10) with four screws (2) and nuts (11). Torque nuts to 275- 300 lb.-ft. (373-407 N•m).
9. Install new lockwasher (4), nut (5), and setscrew (6) on pad (3). Torque nut to 100-150 lb.-ft. (136-203 N•m).

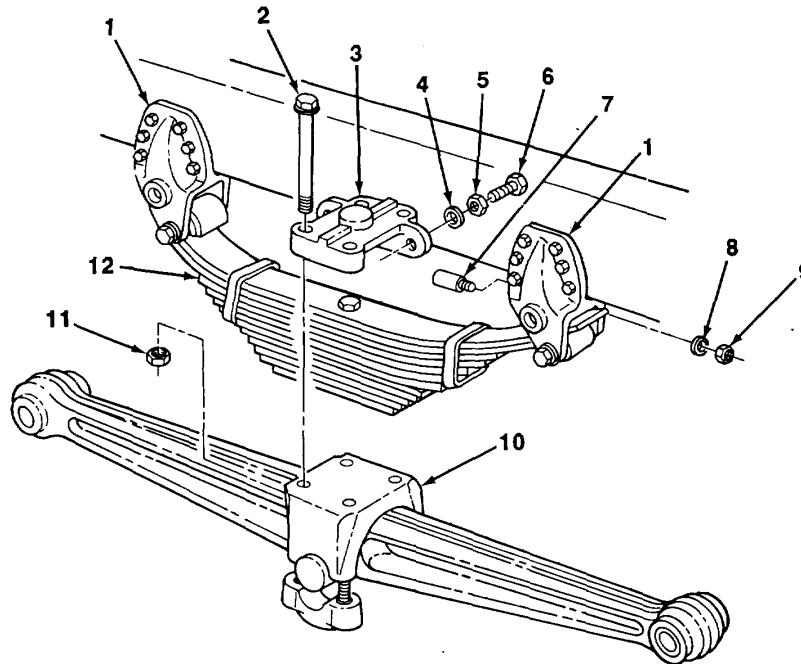
**FOLLOW-ON TASKS:**

- Lubricate rear springs (see LO 5-3805-254-12).

TA704094

13-4. TORQUE ROD REPLACEMENT.

This Task Covers:

- | | | | |
|----|-------------------------|----|--------------|
| a. | Removal | c. | Installation |
| b. | Cleaning and Inspection | | |

Initial Setup:

Materials/Parts:

- Dry cleaning solvent (Item 23, Appendix B)
- Four lockwashers

Tools/Test Equipment:

- General mechanic's tool kit
- Field automotive shop set

General Safety Instructions:

- Dry cleaning solvent is flammable and must not be used near open flame. Use only in a well-ventilated area.
-

a. REMOVAL

1. Remove nut (5) and screw (2) from bracket (4).
2. Remove machine key (1) from torque rod (6).
3. Remove machine key (7) from torque rod (6).
4. Remove four screws (12), lockwashers (11), torque rod bracket (10), and dowel pin (9) from frame (8). Discard lockwashers.
5. Remove torque rod (6) from frame (8) and bracket (4).
6. Repeat steps 1 through 5 to remove torque rod (3).

13-4. TORQUE ROD REPLACEMENT (Con't).

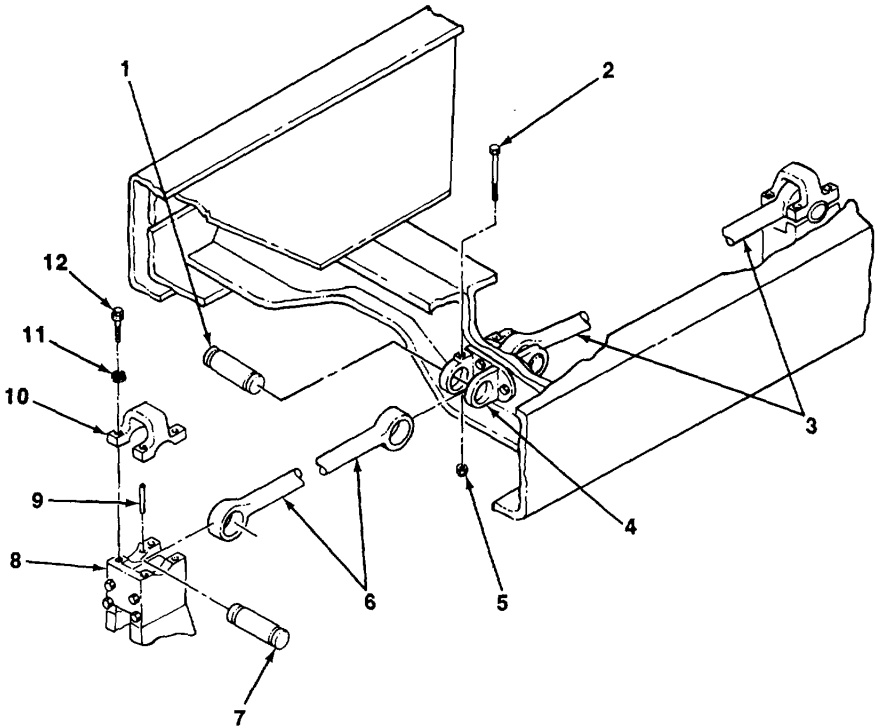

NOTE

Both torque rods must be removed to replace brackets.

- 7. If damaged, remove four nuts (17), screws (13), two brackets (4 and 16), and plates (14 and 15) from frame (8).

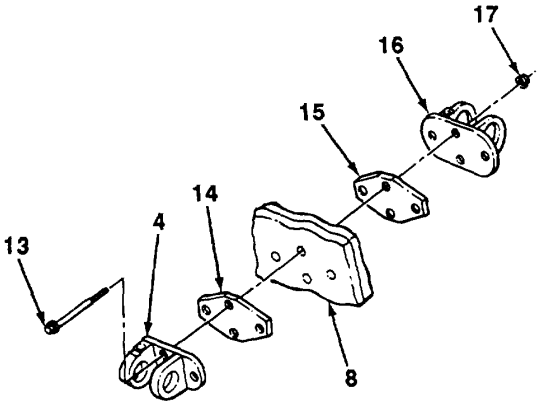

13-4. TORQUE ROD REPLACEMENT (Con't).

b. CLEANING AND INSPECTION

Dry cleaning solvent, P-D-680, is toxic and flammable. Always wear protective goggles and gloves, and use only in a well-ventilated area. Avoid contact with skin, eyes, and clothes, and DO NOT breathe vapors. DO NOT use near open flame or excessive heat. The solvent's flash point is 100°F-138°F (38°C-59°C). If you become dizzy while using cleaning solvent, immediately get fresh air and medical help. If solvent contacts eyes, immediately wash your eyes and get medical aid.

1. Clean all parts with dry cleaning solvent.
2. Inspect bushing (20) for damage. If damaged, remove two retaining rings (18) and bushing from torque rods (3 and 6).
3. Inspect two lubrication fittings (19) for damage. Replace lubrication fittings if damaged.
4. Inspect torque rods (3 and 6) for damage. Replace if damaged.

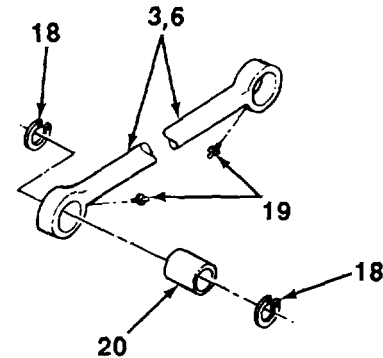

c. INSTALLATION

1. If removed, install two plates (14 and 15) and brackets (4 and 16) on frame (8) with four screws (13) and nuts (17). Torque nuts to 250-275 lb.-ft. (339-373 N•m).

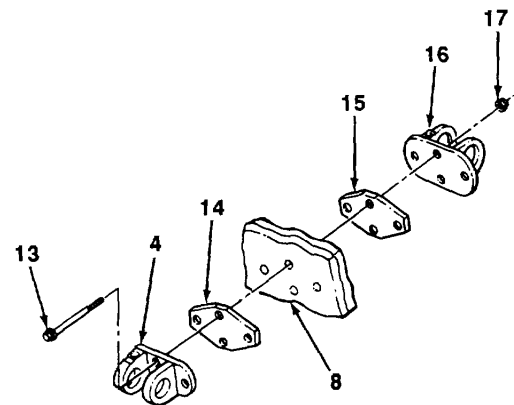

13-4. TORQUE ROD REPLACEMENT (Con't).

2. Position torque rod (6) on bracket (4) and frame (8).
3. Install dowel pin (9) and torque rod bracket (10) on frame (8) with four new lockwashers (11) and screws (12).
4. Install machine key (7) on torque rod (6).
5. Install machine key (1) on torque rod (6).
6. Install screw (2) and nut (5) on bracket (4). Torque nut to 250 lb.-ft. (339 N-m).
7. Repeat steps 2 through 6 to install torque rod (3).

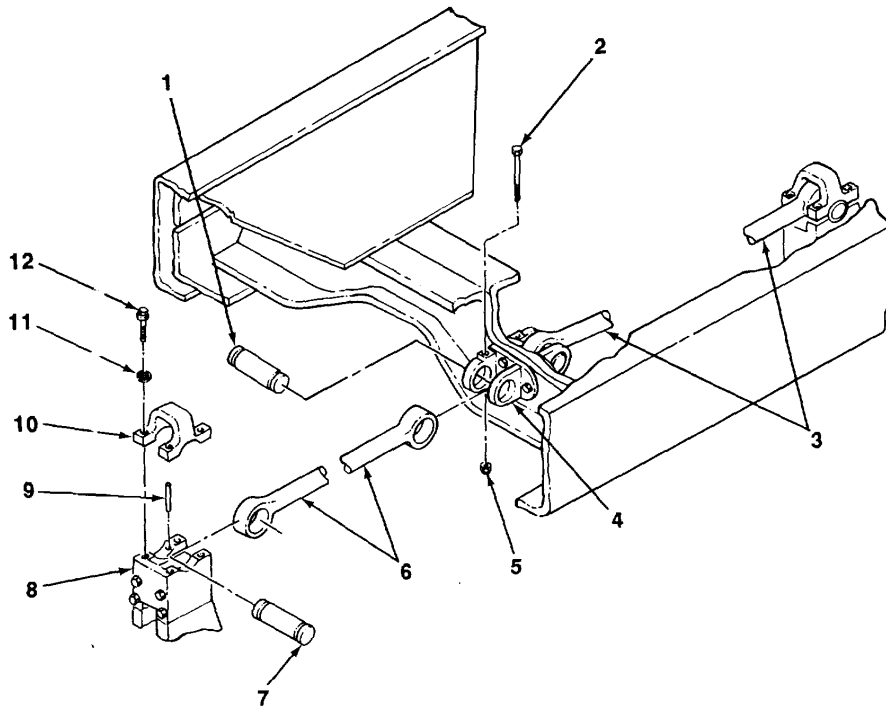
**FOLLOW-ON TASKS:**

- Lubricate torque rods (see LO 5-3805-254-12).

**CHAPTER 14
FRAME MAINTENANCE**

Paragraph Number	Paragraph Title	Page Number
14-1	Grille Guard Replacement.....	14-1
14-2	Bumper Replacement	14-3
14-3	Frame Tie Tube Replacement	14-6
14-4	Body Subframe Maintenance1	4-7
14-5	Channel Replacement.....	14-9
14-6	Engine Crossmember and Brackets Replacement	14-11
14-7	Frame Reinforcement Replacement	14-14
14-8	Cab Crossmember Brackets Replacement	14-16
14-9	Bogie Crossmember and Brackets Replacement	14-17
14-10	Torque Rod Crossmembers and Gussets Replacement	14-18
14-11	Rear Crossmember and Gussets Replacement	14-20
14-12	Frame Repair	14-21
14-13	Radiator Support Replacement.....	14-22

14-1. GRILLE GUARD REPLACEMENT.

This Task Covers:

- | | |
|------------|-----------------|
| a. Removal | b. Installation |
|------------|-----------------|

Initial Setup:

Materials/Parts:

- Eight locknuts
- Field automotive shop set

Tools/Test Equipment:

- General mechanic's tool kit

Personnel Required: Two

14-1. GRILLE GUARD REPLACEMENT (Con't).**a. REMOVAL**

1. Using suitable lifting device attached to grille guard (2), raise lifting device just enough to take weight of grille guard off front bumper (4).

NOTE

Two splash plates attached to front bumper will be loosened as grille guard is removed.

2. Remove eight locknuts (3), bolts (1), and grille guard (2) from front bumper (4). Discard locknuts.
3. Move grille guard (2) to storage location and remove lifting device.

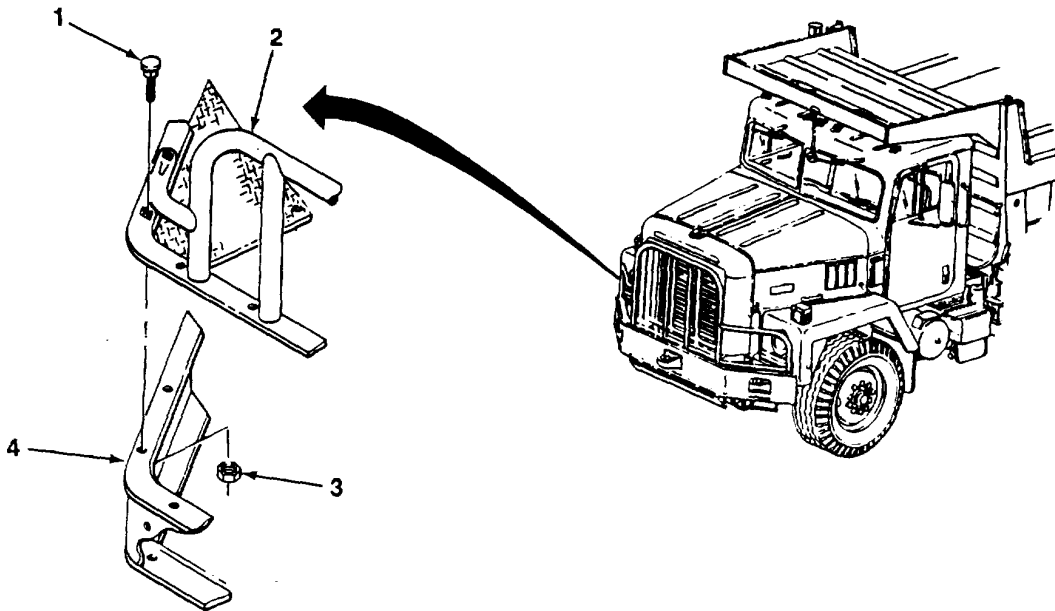
**b. INSTALLATION**

1. Attach lifting device to grille guard (2). Raise grille guard and move to vehicle.
2. Install grille guard (2) to front bumper (4) with eight bolts (1) and new locknuts (3).
3. Remove lifting device.

TA704098

14-2. BUMPER REPLACEMENT.

This Task Covers:

- a. Removal
- b. Installation

Initial Setup:

Equipment Conditions:

- Slave receptacle removed (see TM 5-3805-254-20).
- Grille guard removed (see paragraph 14-1).

Tools/Test Equipment:

- General mechanic's tool kit
- Field automotive shop set

Personnel Required: Two

a. REMOVAL

NOTE

Perform steps 1 and 2 at left and right side of bumper.

1. Remove two nuts (5) and step (10) from bumper (9). Remove nut (11) from step.

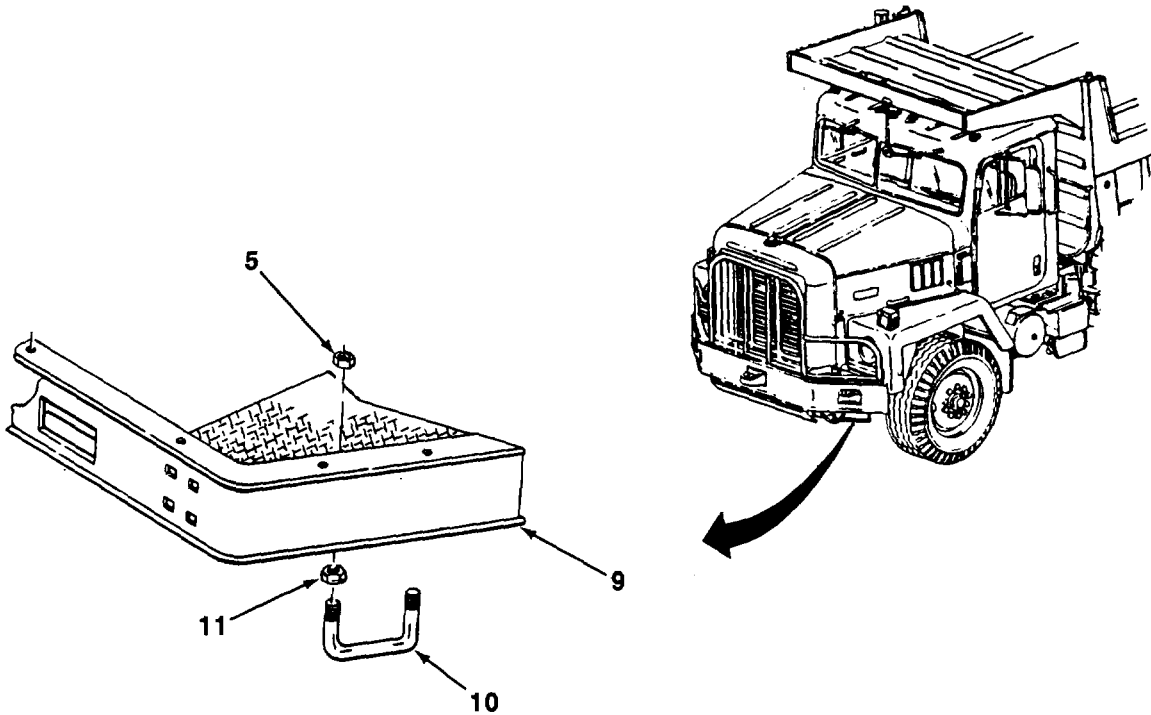

14-2. BUMPER REPLACEMENT (Con't).

- 2. Remove nut (4), screw (2), and support (3) from splash shield (1).
- 3. Using suitable lifting device attached to bumper (9), raise lifting device Just enough to take weight of bumper off two brackets (8).
- 4. Remove eight nuts (6), washers (7), bolts (12), and bumper (9) from vehicle.
- 5. Move bumper (9) to storage location and remove lifting device.
- 6. Remove two screws (14), nuts (13), and supports (3) from bumper (9).

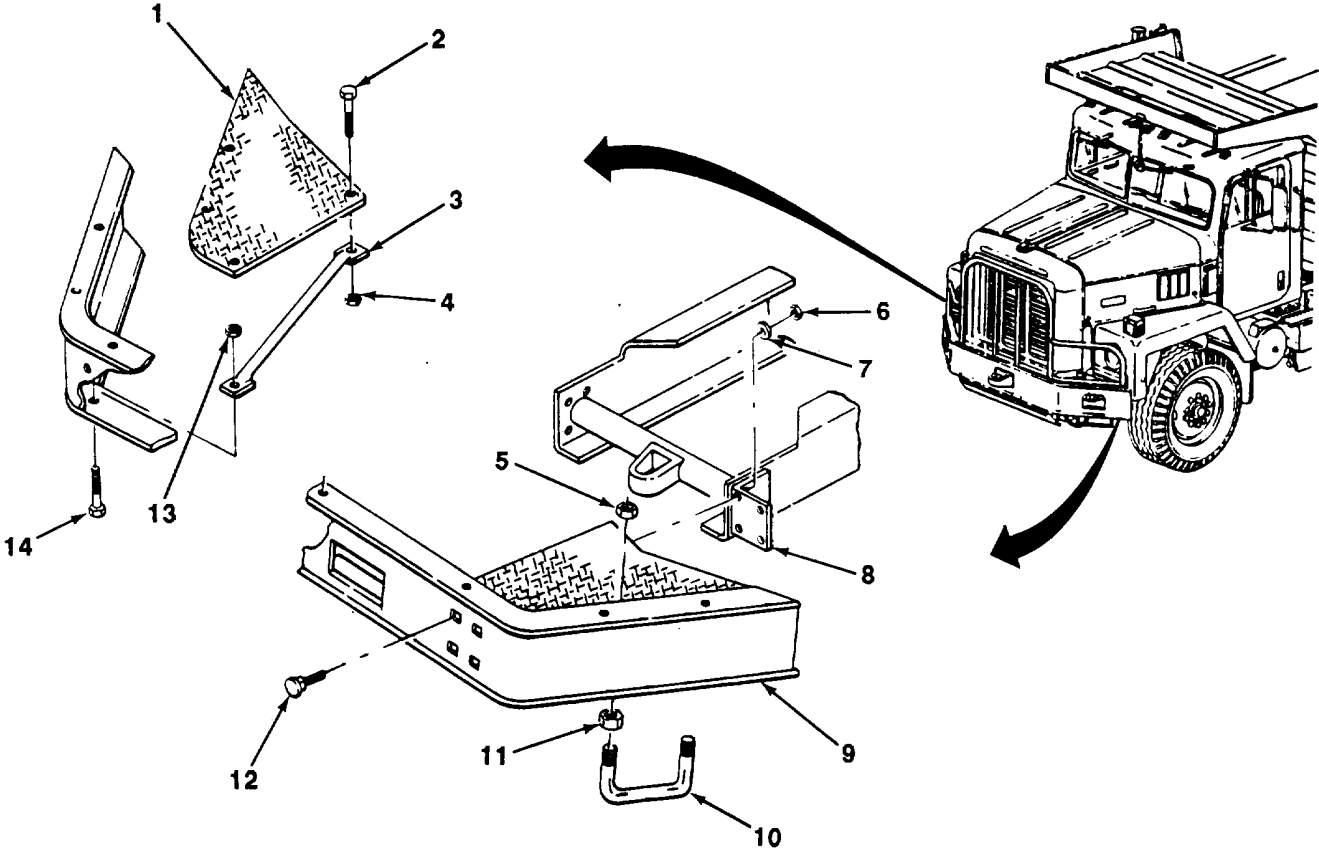

14-2. BUMPER REPLACEMENT (Con't).

7. Remove eight bolts (17), nuts (16), and two brackets (8) from frame (15).
8. Attach lifting device to tow loop crossmember (18) and install tow loop crossmember from frame (15).

b. INSTALLATION

1. Attach lifting device to tow loop crossmember (18) and install tow loop crossmember on frame (15).
2. Install two brackets (8) on frame (15) with eight bolts (17) and nuts (16).

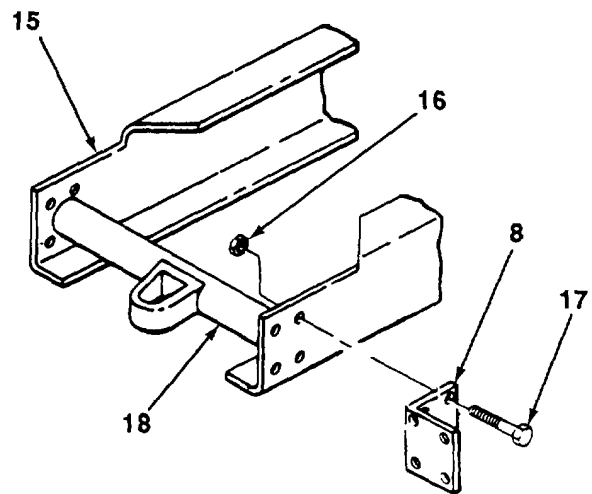

3. Install two supports (3) on bumper (9) with two screws (14) and nuts (13).
4. Attach lifting device to bumper (9). Raise bumper and move to vehicle.
5. Install bumper (9) to two brackets (8) with eight bolts (12), washers (7), and nuts (6).
6. Remove lifting device.

NOTE
Perform steps 7 through 9 at left and right side of bumper.

7. Install support (3) to splash shield (1) with screw (2) and nut (4).
8. Install nut (11) on step (10).
9. Install step (10) on bumper (9) with two nuts (5).

FOLLOW-ON TASKS:

- Install grille guard (see paragraph 14-1).
- Install slave receptacle (see TM 5-3805-254-20).

14-4. BODY SUBFRAME MAINTENANCE.*This Task Covers:*

- | | |
|------------|-----------------|
| a. Removal | c. Installation |
| b. Repair | |

*Initial Setup:***Equipment Conditions**

- Dump body removed (see paragraph 15-36).
- Hydraulic lift cylinder removed (see paragraph 17-1).

Materials/Parts:**References:**

- TM 9-237

Tools/Test Equipment:

- General mechanic's tool kit
- Field automotive shop set
- Welder's tool kit

a. REMOVAL

1. Remove six nuts (1), lockwashers (2), and screws (5) holding two body guides (6) on frame (4). Discard lockwashers.
2. Using metal cutting torch, break welds holding two rear mount guides (3) to subframe (7).

WARNING

Subframe is heavy. Ensure that all personnel are clear before raising subframe to prevent In-jury to personnel.

3. Using a suitable lifting device, remove subframe (7) from frame (4).
4. If damaged, using metal cutting torch, remove two body guides (6) from subframe (7).

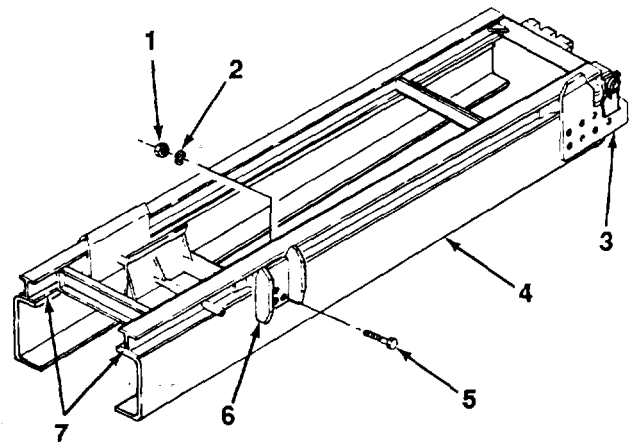

14-4. BODY SUBFRAME MAINTENANCE

b. REPAIR

Refer to TM 9-237 for instructions on subframe repair.

c. INSTALLATION

1. If removed, install two body guides (6) on subframe (7) using welder's tool kit.

WARNING

Subframe is heavy. Ensure that all personnel are clear before raising subframe to prevent In-jury to personnel.

2. Using a suitable lifting device, raise subframe (7) and position over frame (4).
3. Install two body guides (6) to frame (4) with six screws (5), new lockwashers (2), and nuts (1).
4. Using welder's tool kit, weld two rear mount guides (3) to subframe (7).

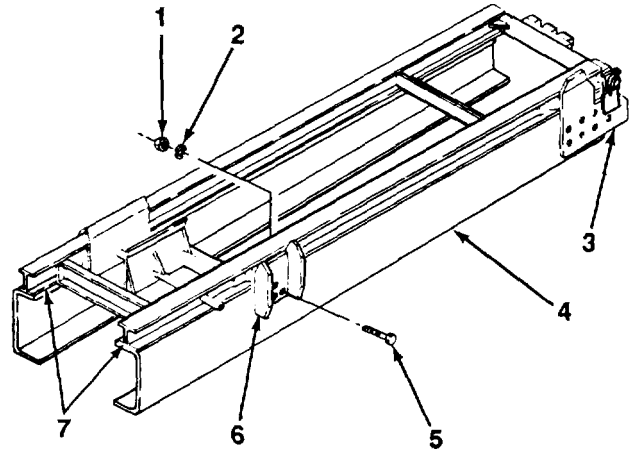
**FOLLOW-ON TASKS:**

- Install hydraulic lift cylinder (see paragraph 17-1).
- Install dump body (see paragraph 15-36).

TA704104

14-5. CHANNEL REPLACEMENT.

This Task Covers:

- a. Removal
 - b. Installation
-

Initial Setup:

Tools/Test Equipment:

- General mechanic's tool kit

Personnel Required: Two

a. REMOVAL

1. Remove four nuts (5), screws (4), and channel (2) from two brackets (7).
2. Remove four nuts (3), screws (6), and two brackets (7) from frame (1).

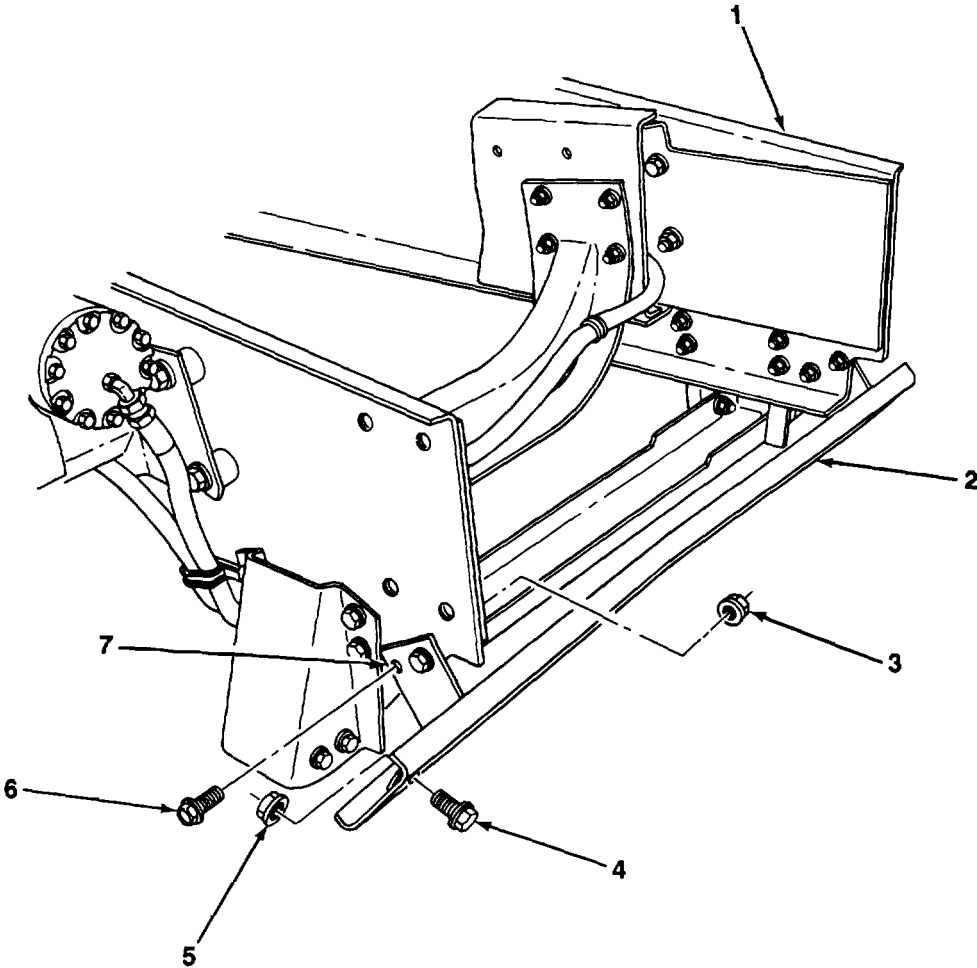

14-5. CHANNEL REPLACEMENT (Con't).

b. INSTALLATION

- 1. Install two brackets (7) on frame (1) with four screws (6) and nuts (3).
- 2. Install channel (2) on two brackets (7) with four screws (4) and nuts (5).

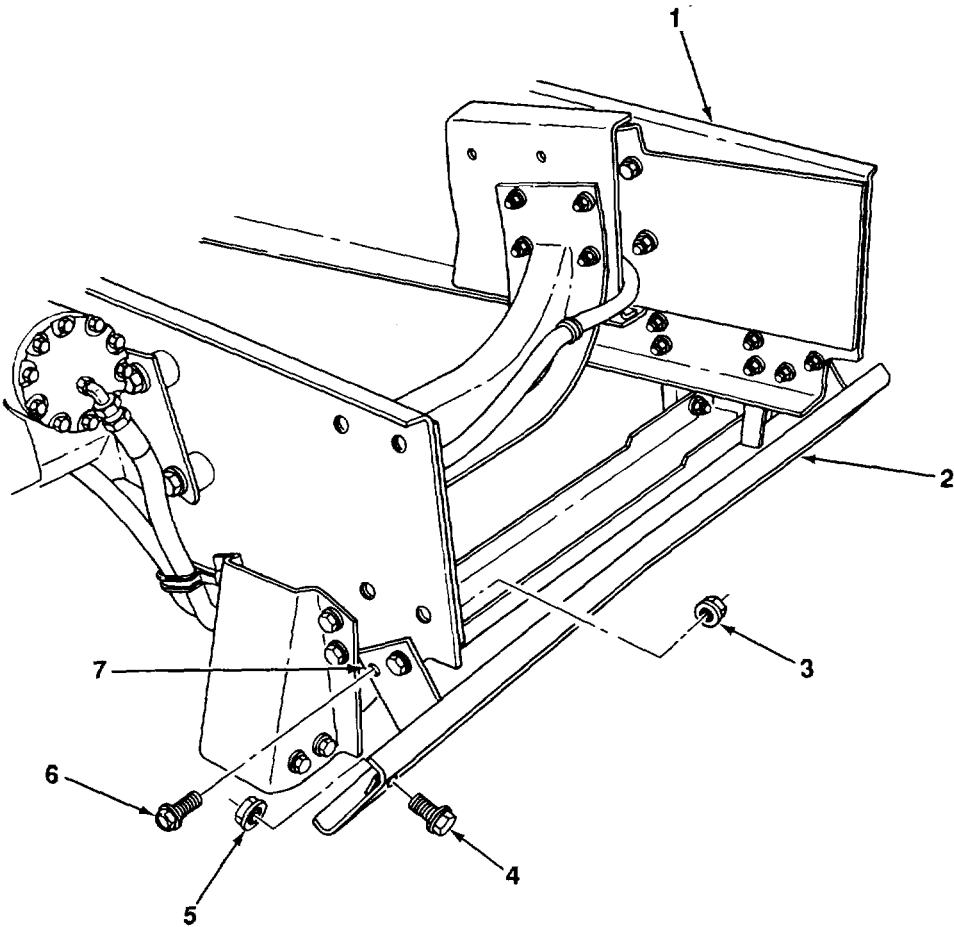

14-6. ENGINE CROSSMEMBER AND BRACKETS REPLACEMENT.*This Task Covers:*

a. Removal

b. Installation

*Initial Setup:***Equipment Conditions:**

- Radiator removed (see paragraph 4-4).
- Engine mounting brackets removed from engine crossmember (see paragraph 3-3).

Tools/Test Equipment:

- General mechanic's tool kit
- Field automotive shop set

Personnel Required: Two**a. REMOVAL**

1. Remove two nuts (7) and screws (8), and remove two clamps (9) and wiring harness (5) from engine crossmember.
2. Remove four nuts (3) and screws (2) from engine crossmember (6) and left crossmember bracket (4).
3. Remove four nuts (3) and screws (2) from engine crossmember (6) and right crossmember bracket (1). Remove engine crossmember.

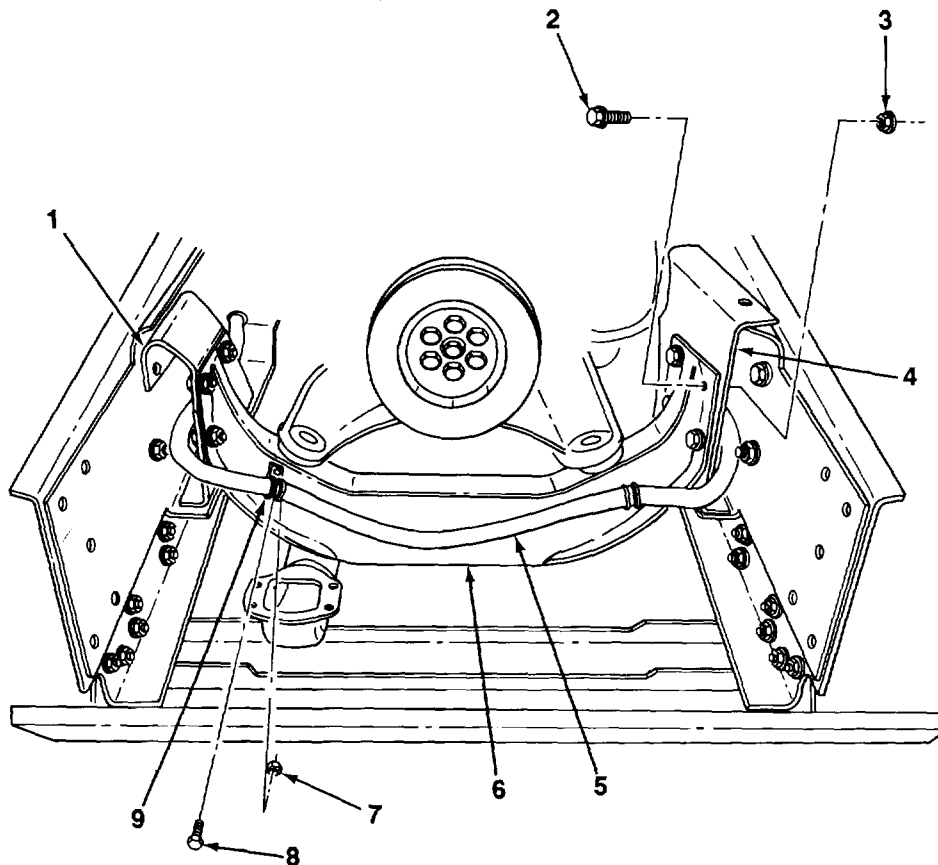

14-6. ENGINE CROSSMEMBER AND BRACKETS REPLACEMENT (Con't).

NOTE

Left and right crossmember brackets are different. Remove only if damaged.

- 4. Remove eight nuts (12), screws (11), and right and left crossmember brackets (1 and 4) from frame (10).

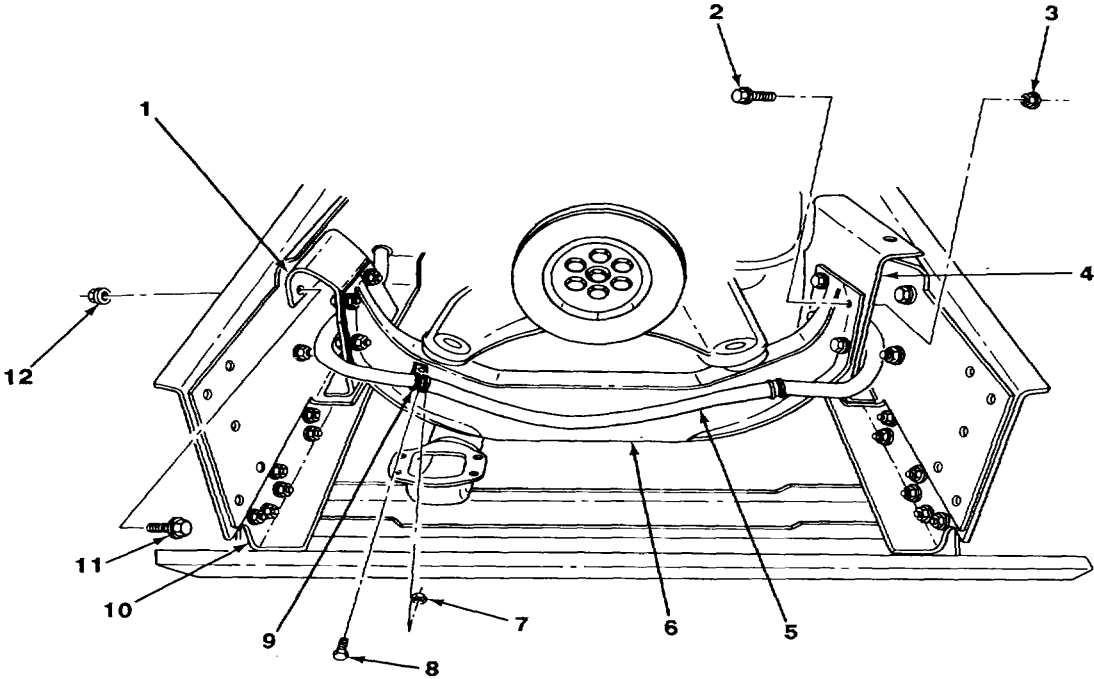

14-6. ENGINE CROSSMEMBER AND BRACKETS REPLACEMENT (Con't).

5. Remove spacer bar (13) from between left crossmember bracket (4) and frame (10).

b. INSTALLATION

1. Aline spacer bar (13) and left crossmember bracket (4) with holes in frame (10) and install left crossmember bracket with four screws (11) and nuts (12).

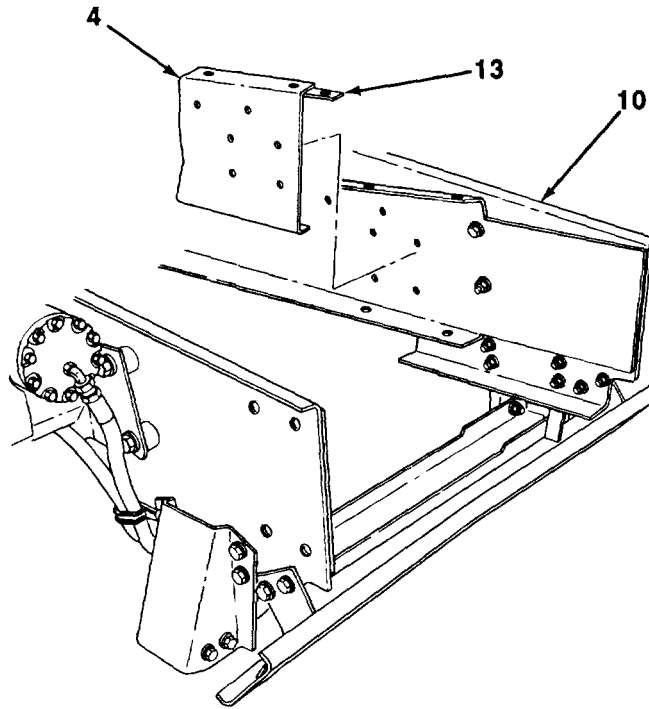

2. Install right crossmember bracket (1) on frame (10) with four screws (11) and nuts (12).
3. Install engine crossmember (6) on right and left crossmember brackets (1 and 4) with eight screws (2) and nuts (3).
4. Install wiring harness (5) on engine crossmember (6) with two clamps (9), screws (8), and nuts (7).

FOLLOW-ON TASKS:

- Install engine mounting brackets to engine crossmember (see paragraph 3-3).
- Install radiator (see paragraph 4-4).

14-7. FRAME REINFORCEMENT REPLACEMENT.

This Task Covers:

- a. Removal
- b. Installation

Initial Setup:

Equipment Conditions:

- Channel removed (see paragraph 14-5).
- Radiator support removed (see paragraph 14-13).
- Engine crossmember and brackets removed (see paragraph 14-6).
- Left and right power steering gear removed (see paragraph 12-1).

Tools/Test Equipment:

- General mechanic's tool kit
- Field automotive shop set

Personnel Required: Two

a. REMOVAL

1. Remove nut (1), screw (7), washer (8), and ground wire (9) from frame (4).
2. Remove four nuts (3), screws (5), and left and right reinforcements (2 and 6) from frame (4).

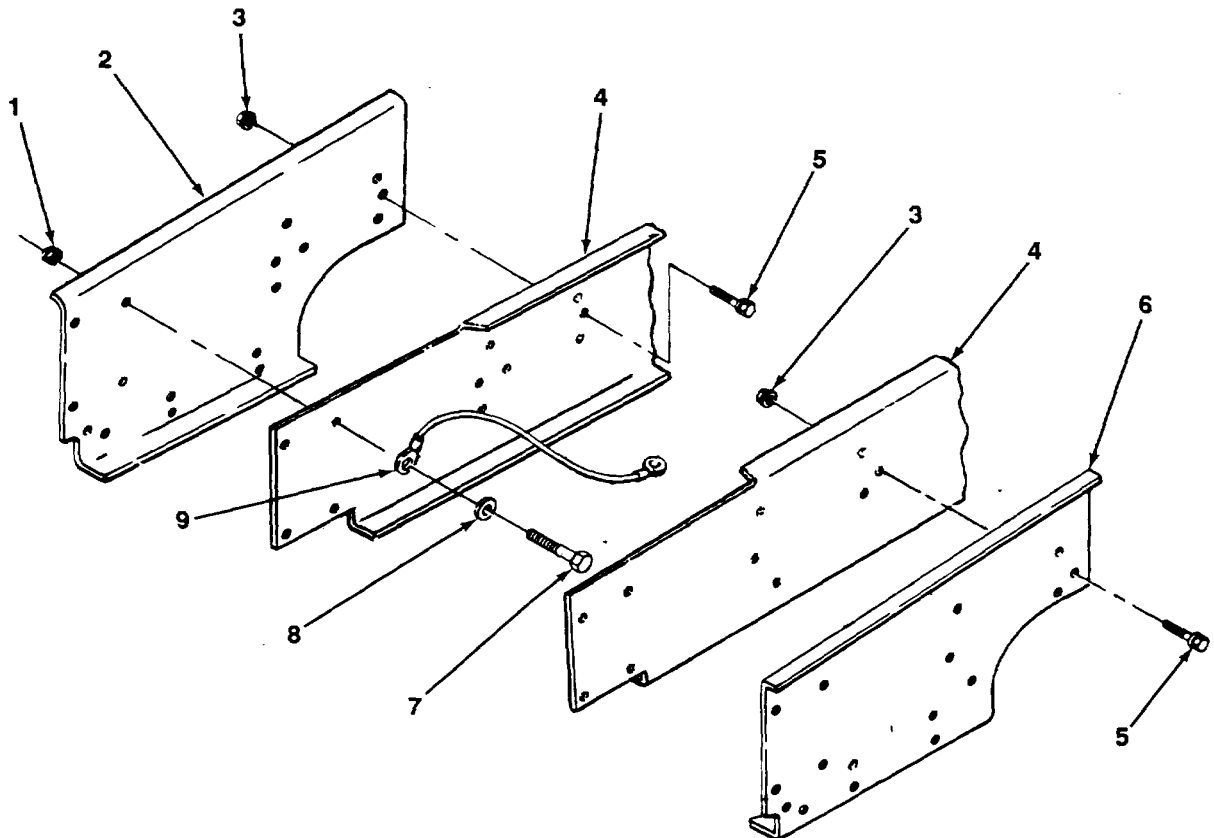

14-7. FRAME REINFORCEMENT REPLACEMENT (Con't).

b. INSTALLATION

1. Install left and right reinforcements (2 and 6) on frame (4) with four screws (5) and nuts (3).
2. Install ground wire (9) on frame (4) with washer (8), screw (7), and nut (1).

FOLLOW-ON TASKS:

- Install left and right power steering gear (see paragraph 12-1).
- Install engine crossmember and brackets (see paragraph 14-6).
- Install radiator support (see paragraph 14-13).
- Install channel (see paragraph 14-5).

14-8. CAB CROSSMEMBER BRACKETS REPLACEMENT.*This Task Covers:*

- a. Removal b. Installation

*Initial Setup:***Equipment Conditions:**

- Front fuel tank supports removed (see TM 5-3805-254-20).
- Battery box and brackets removed (see TM 5-3805-254-20).
- Cab crossmember removed (see paragraph 15-4).

Tools/Test Equipment:

- General mechanic's tool kit
- Field automotive shop set

Personnel Required: Two**NOTE****Left and right crossmember brackets are replaced in the same manner.****a. REMOVAL**

Remove 12 nuts (1), screws (4), and two crossmember brackets (3) from frame (2).

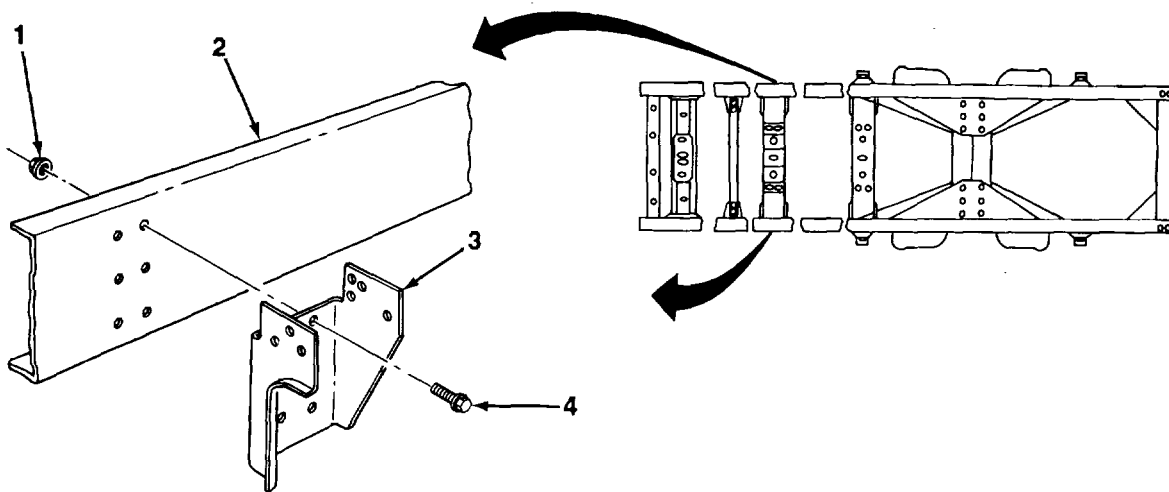
**b. INSTALLATION**

Install two crossmember brackets (3) on frame (2) with 12 screws (4) and nuts (1).

FOLLOW-ON TASKS:

- Install battery box and brackets (see TM 5-3805-254-20).
- Install front fuel tank supports (see TM 5-3805-254-20).
- Install cab crossmember (see paragraph 15-4).

TA704111

14-9. BOGIE CROSSMEMBER AND BRACKETS REPLACEMENT.*This Task Covers:*

a. Removal

b. Installation

*Initial Setup:***Equipment Conditions:**

- Anchor hose, clamps, and extensions removed from bogie crossmember (see TM 5-3805-254-20).

Tools/Test Equipment:

- General mechanic's tool kit
- Field automotive shop set

Personnel Required: Two**a. REMOVAL**

- Remove 16 nuts (2), screws (1), and bogie crossmember (3) from four brackets (7).
- Remove 12 nuts (4), screws (6), and four brackets (7) from frame (5).

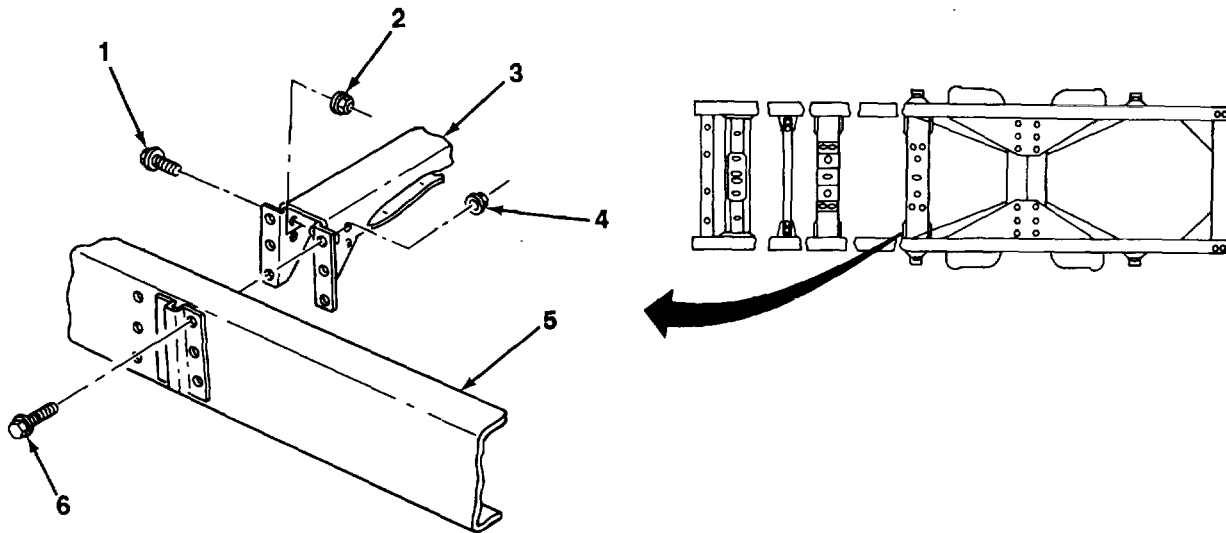
**b. INSTALLATION**

- Install four brackets (7) on frame (5) with 12 screws (6) and nuts (4).
- Install bogie crossmember (3) on four brackets (7) with 16 screws (1) and nuts (2).

FOLLOW-ON TASKS:

- Install extensions, clamps, and anchor hose on bogie crossmember (see TM 5-3805-254-20).

TA704112

14-10. TORQUE ROD CROSSMEMBERS AND 3;USSTS RE1PLACEMENT.

This Task Covers:

- a. Removal b. Installation

Initial Setup:

Equipment Conditions:

- Body subframe removed (see paragraph 14-4).
- Rear spring brackets and axle stops removed (see paragraph 13-3).
- Torque rods removed (see paragraph 13-4).

Tools/Test Equipment:

- General mechanic's tool kit
- Field automotive shop set

Personnel Required: Two

a. REMOVAL

1. Remove eight nuts (3) and screws (5) from two lower gussets (7) and frame (2).
2. Remove eight nuts (4) and screws (6) from two upper gussets (1) and frame (2).

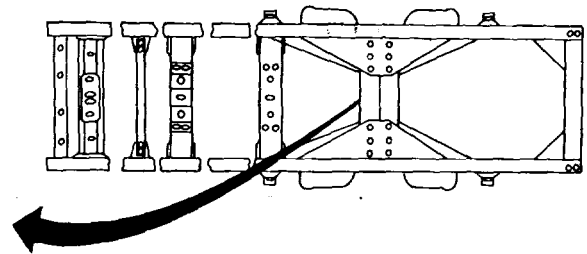
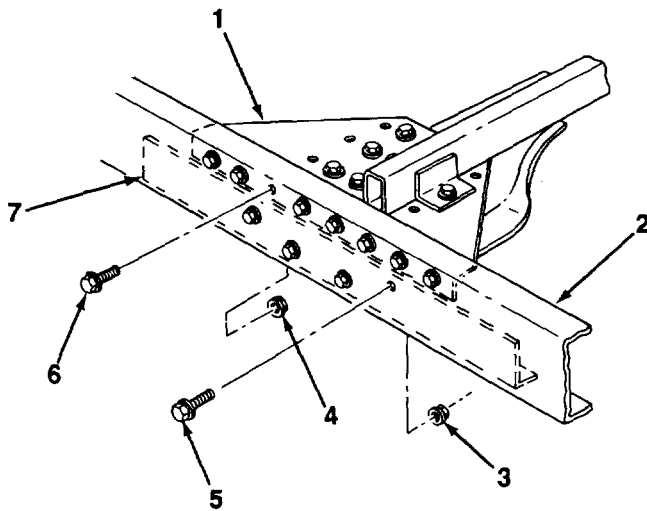

14-10. TORQUE ROD CROSSMEMBERS AND GUSSETS REPLACEMENT (Con't).

3. Remove nut (11) and screw (9) from frame crossmember (10) and upper gusset (1).
4. Remove 16 nuts (14), screws (8), two upper gussets (1), crossmembers (12 and 13), and two lower gussets (7) from frame (2).

b. INSTALLATION

1. Install two lower gussets (7), crossmembers (12 and 13), and two upper gussets (1) to frame (2) with 16 screws (8) and nuts (14).
2. Install screw (9) and nut (11) to frame crossmember (10) and upper gusset (1).

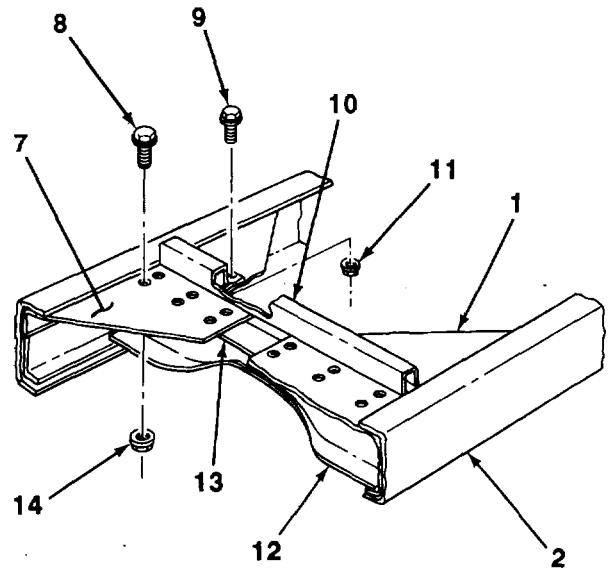

3. Install eight screws (6) and nuts (4) to two upper gussets (1) and frame (2).
4. Install eight screws (5) and nuts (3) to two lower gussets (7) and frame (2).

FOLLOW-ON TASKS:

- Install torque rods (see paragraph 13-4).
- Install rear spring brackets and axle stops (see paragraph 13-3).
- Install body subframe (see paragraph 14-4).

TA704114

14-11. REAR CROSSMEMBER AND GUSSETS REPLACEMENT.*This Task Covers:*

- | | |
|------------|-----------------|
| a. Removal | b. Installation |
|------------|-----------------|

*Initial Setup:***Equipment Conditions:**

- Body subframe removed (see paragraph 14-4).
- Stoplight-taillights removed (see TM 5-3805-254-20).
- Pintle hook removed (see TM 5-3805-254-20).

Tools/Test Equipment:

- General mechanic's tool kit
- Field automotive shop set

Personnel Required: Two**a. REMOVAL**

1. Remove three nuts (12), screws (14), spacer (13), and pintle hook mounting bracket (11) from rear crossmember (9).
2. Remove eight nuts (6) and screws (7) from frame (1) and rear crossmember (9).
3. Remove six nuts (3), screws (4), and two top gussets (2) from rear crossmember (9).
4. Remove eight nuts (5), screws (8), two brackets (15), rear crossmember (9), and two bottom gussets (10) from frame (1).

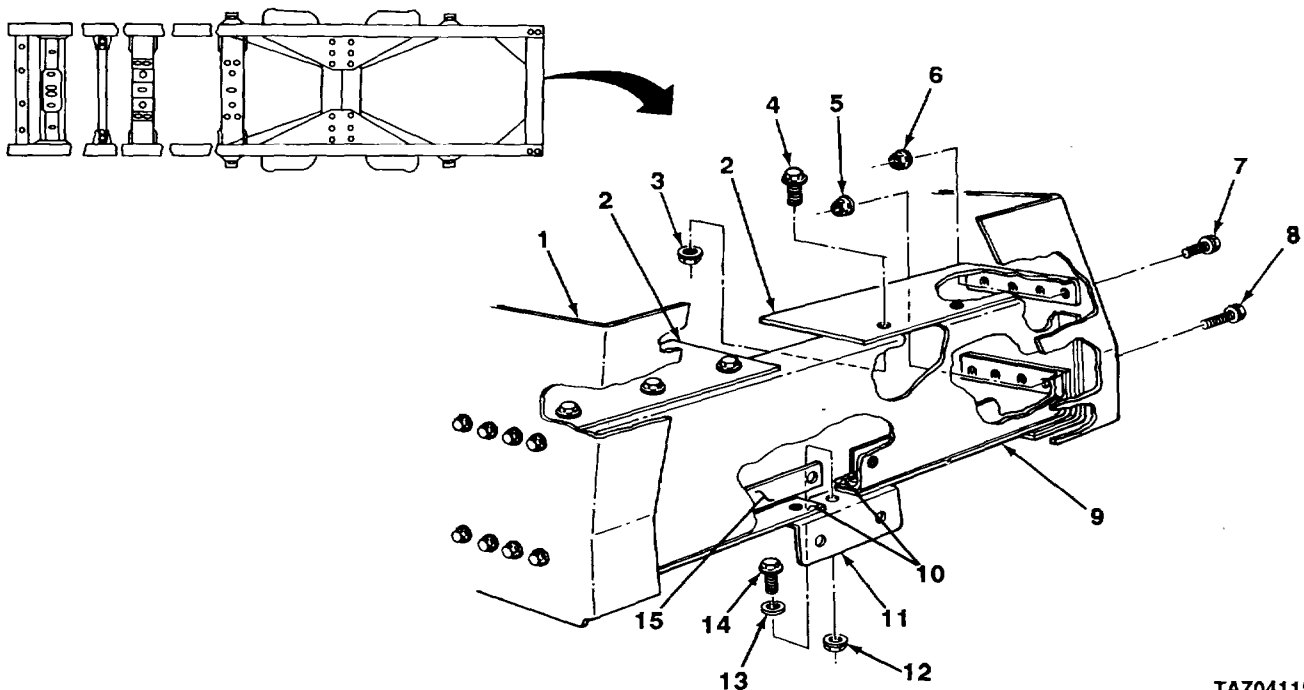

TA704115

TA704115

14-11. REAR CROSSMEMBER AND GUSSETS REPLACEMENT (Con't).

b. INSTALLATION

1. Install two bottom gussets (10), rear crossmember (9), and two brackets (15) on frame (1) with eight screws (8) and nuts (5).
2. Install two top gussets (2) on rear crossmember (9) with six screws (4) and nuts (3).
3. Install eight screws (7) and nuts (6) securing rear crossmember (9) to frame (1).
4. Install pintle hook mounting bracket (11) on rear crossmember (9) with spacer (13), three screws (14), and nuts (12).

FOLLOW-ON TASKS:

- Install pintle hook (see TM 5-3805-254-20).
- Install stoplight-taillights (see TM 5-3805-254-20).
- Install body subframe (see paragraph 14-4).

14-12. FRAME REPAIR.

Frame repair is limited to welding, straightening, and reconditioning of damaged parts. Refer to TB 9-2300-247-40 for more information on repair of frames.

14-13. RADIATOR SUPPORT REPLACEMENT.

This Task Covers:

- a. Removal
- b. Installation

Initial Setup:

Equipment Conditions:

- Radiator removed (see paragraph 4-4).

Tools/Test Equipment:

- General mechanic's tool kit

a. REMOVAL

NOTE

Perform step 1 at left and right side of radiator support.

1. Remove four nuts (5), bolts (7), and support channel (1) from bracket (6).

NOTE

Perform step 2 at left and right side of vehicle frame.

2. Remove four nuts (2), bolts (4), steering hose bracket (3), and frame bracket (6) from frame (8).

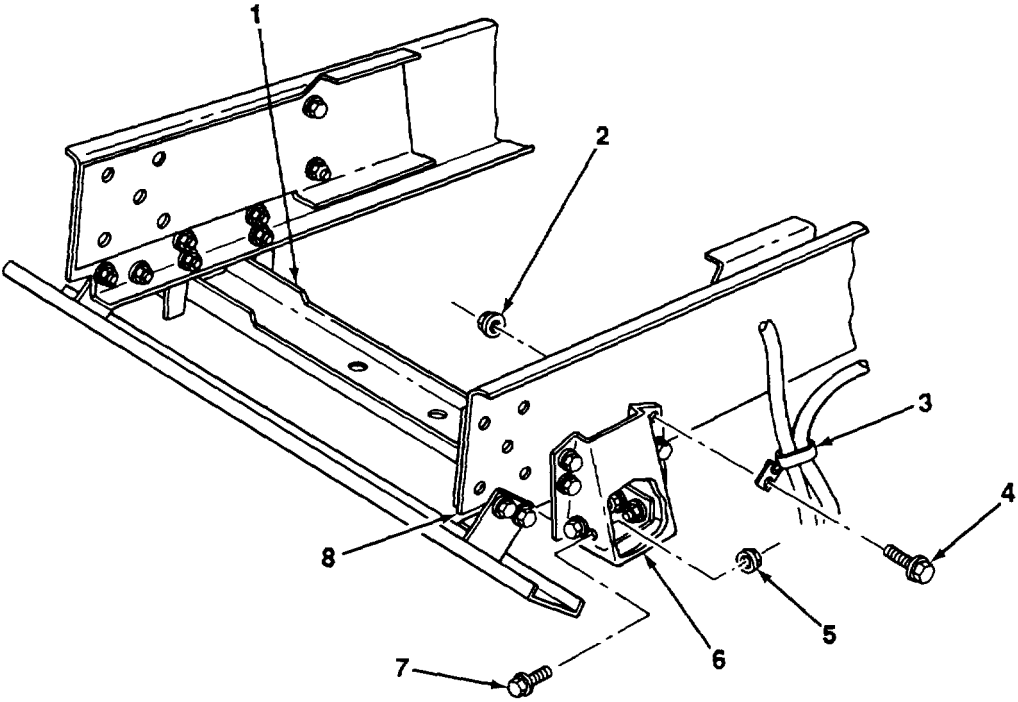

14-13. RADIATOR SUPPORT REPLACEMENT (Con't).

b. INSTALLATION**NOTE**

Perform step 1 at left and right side of vehicle frame.

1. Install frame bracket (6) and steering hose bracket (3) to frame (8) with four bolts (4) and nuts (2).

NOTE

Perform step 2 at left and right side of radiator support.

2. Install support channel (1) on frame bracket (6) with four bolts (7) and nuts (5).

FOLLOW-ON TASKS:

- Install radiator (see paragraph 4-4).

14-23/(14-24 Blank)

CHAPTER 15
BODY AND ACCESSORIES MAINTENANCE

Paragraph Number	Paragraph Title	Page Number
15-1	Engine Cover Replacement	15-2
15-2	Floormats Replacement	15-4
15-3	Floorboards and Inserts Replacement	15-7
15-4	Cab Assembly Maintenance.....	15-13
15-5	Cab Rear Trim Replacement	15-21
15-6	Coat Hook Replacement	15-24
15-7	Rear Window Molding Replacement.....	15-25
15-8	Cab Door Opening Weatherseal Replacement.....	15-26
15-9	Door Check Replacement	15-28
15-10	Dovetail Replacement	15-29
15-11	Cowl Ventilator Replacement.....	15-30
15-12	Air Intake Duct Replacement	15-31
15-13	Cab Door Panels Replacement.....	15-32
15-14	Cab Door Handles Replacement	15-36
15-15	Cab Door Glass and Window Regulator Replacement.....	15-38
15-16	Cab Door and Hinge Replacement	15-42
15-17	Right Door View Glass Replacement.....	15-44
15-18	Vent Window Replacement.....	15-47
15-19	Sunvisor Replacement	15-49
15-20	Radio Opening Cover Replacement.....	15-51
15-21	Instrument Panel Pad Replacement	15-52
15-22	Instrument Panels Replacement	15-54
15-23	Headlining Replacement	15-58
15-24	Fender Maintenance	15-60
15-25	Windshield Glass Replacement	15-65
15-26	Cab Rear Glass Replacement	15-68
15-27	Tailgate Release Lever and Linkage Replacement	15-70
15-28	Tailgate Replacement	15-77
15-29	Driver's Seat Air Spring Replacement.....	15-80
15-30	Driver's Seat Shock Absorber Replacement.....	15-81
15-31	Driver's Seat Repair	15-82
15-32	Heater Fan Motor Replacement.....	15-93
15-33	Heater Core and Bracket Replacement	15-97
15-34	Heater Control and Control Panel Replacement.....	15-101
15-35	Heater Box Replacement	15-104
15-36	Dump Body Replacement	15-106

15-1. ENGINE COVER REPLACEMENT.

This Task Covers:

- | | |
|-------------|-----------------|
| a. Removal | c. Installation |
| b. Cleaning | |
-

Initial Setup:

Materials/Parts:

- Detergent (Item 6, Appendix B)
- Rags (Item 17, Appendix B)
- Sealant (Item 19, Appendix B)
- One seal

Tools/Test Equipment:

- General mechanic's tool kit
-

a. REMOVAL

1. Pull floormat (6) and insulation (7) back from center floor cover plate (8) and expose screws (4).
2. Remove 14 screws (4), flatwashers (3), bracket (2), and engine cover (5) from firewall (9).
3. Remove seal (1) from firewall (9). Discard seal.

b. CLEANING

Clean engine cover (5) in detergent and water solution. Rinse with clean water and wipe dry.

c. INSTALLATION

1. Apply sealant to new seal (1) and install seal on firewall (9).
2. Install engine cover (5) and bracket (2) on firewall (9) with 14 washers (3) and screws (4).
3. Position Insulation (7) and floormat (6) on center floor cover plate (8).

15-1. ENGINE COVER REPLACEMENT (Con't).

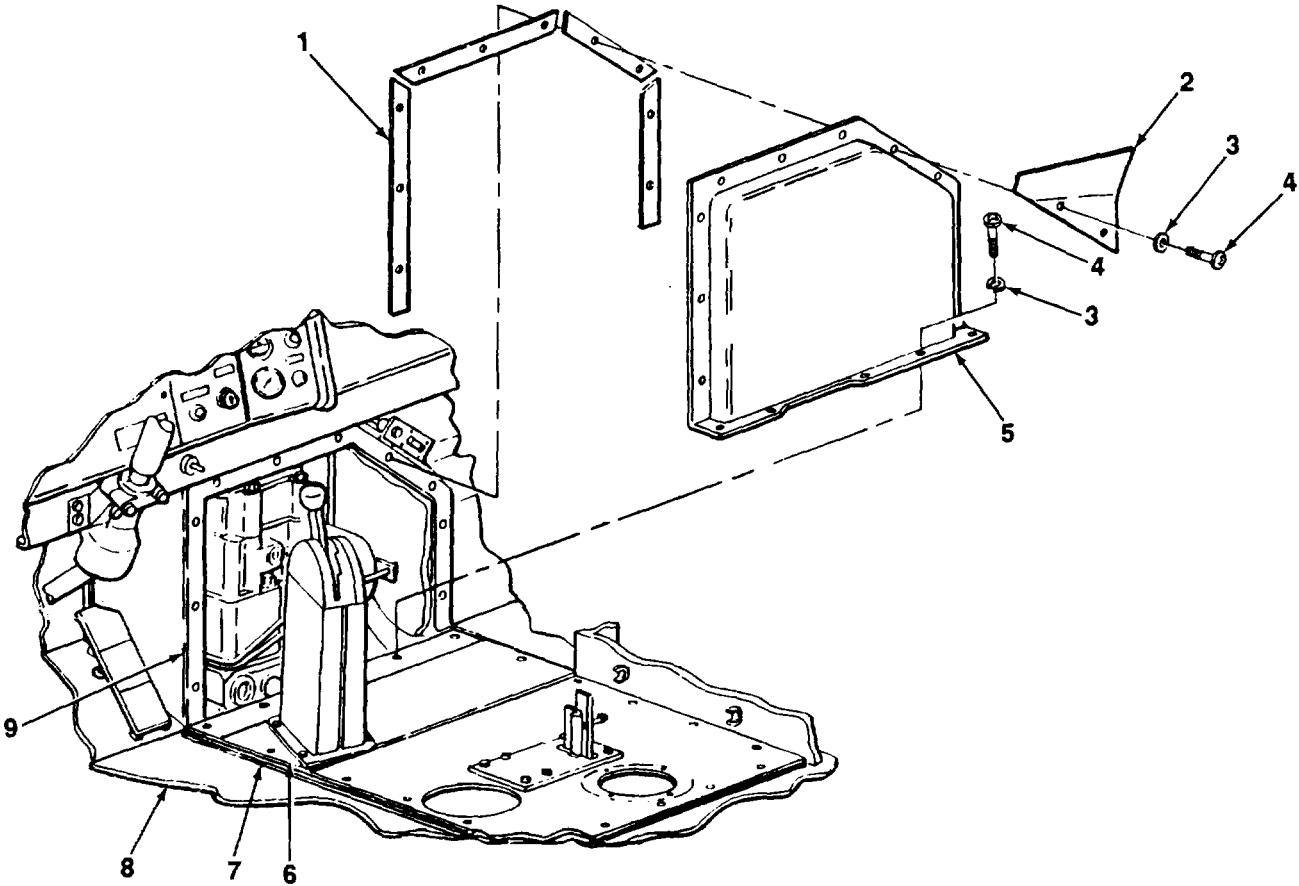

15-2. FLOORMATS REPLACEMENT.

This Task Covers:

a. Removal

b. Installation

Initial Setup:

Equipment Conditions:

- Driver's seat removed (see TM 5-3805-254-20).

Materials/Parts:

- One seal

Tools/Test Equipment:

- General mechanic's tool kit

a. REMOVAL

CAUTION

Do not bend or crimp air line when removing lower rear molding.

1. Remove six screws (5), flatwashers (4), and lower rear molding (3) from rear cab wall (2).
2. Remove three screws (8), flatwashers (9), and lower rear molding (1) from rear cab wall (2).
3. Remove 14 screws (7) and scuff plate (6) from cab.

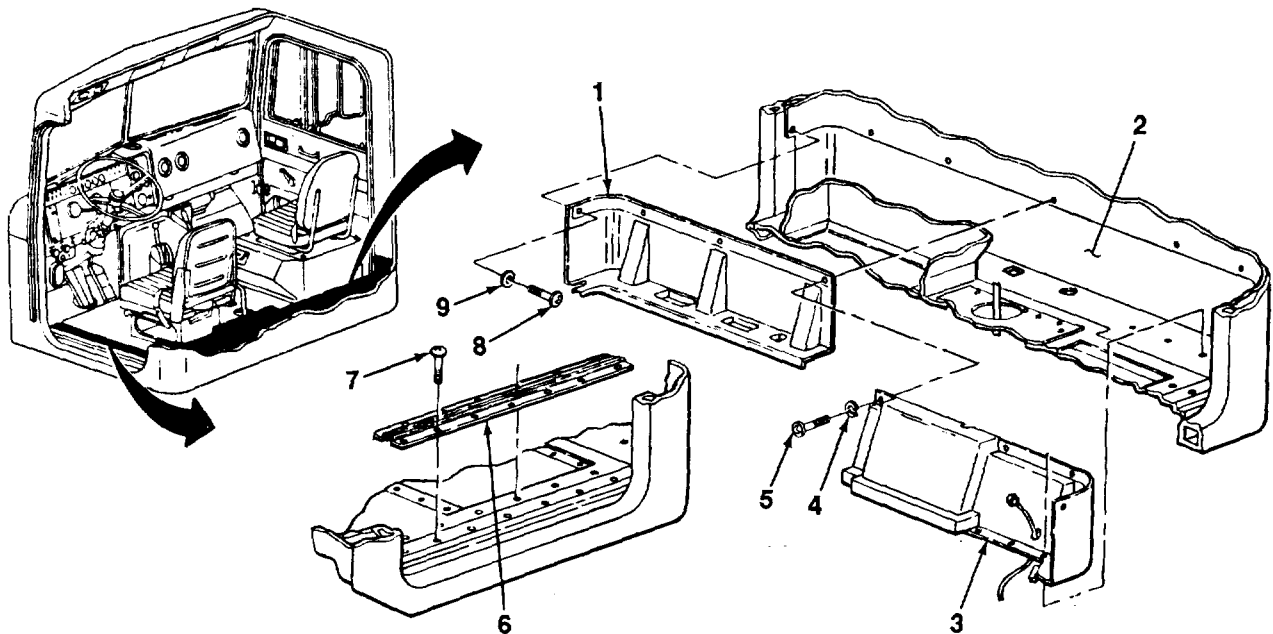

15-2. FLOORMATS REPLACEMENT (Con't).

4. Remove handle (11), four screws (12), seal retainer (13), and seal (14) from auxiliary transmission shift lever (19) and left side floormat (21). Discard seal.
5. Remove left side floormat (21) and insulation (20) from left side floorboard (18).
6. Remove nine screws (15) and scuff plate (16) from cab.
7. Remove right side floormat (10) from right side floorboard (17).

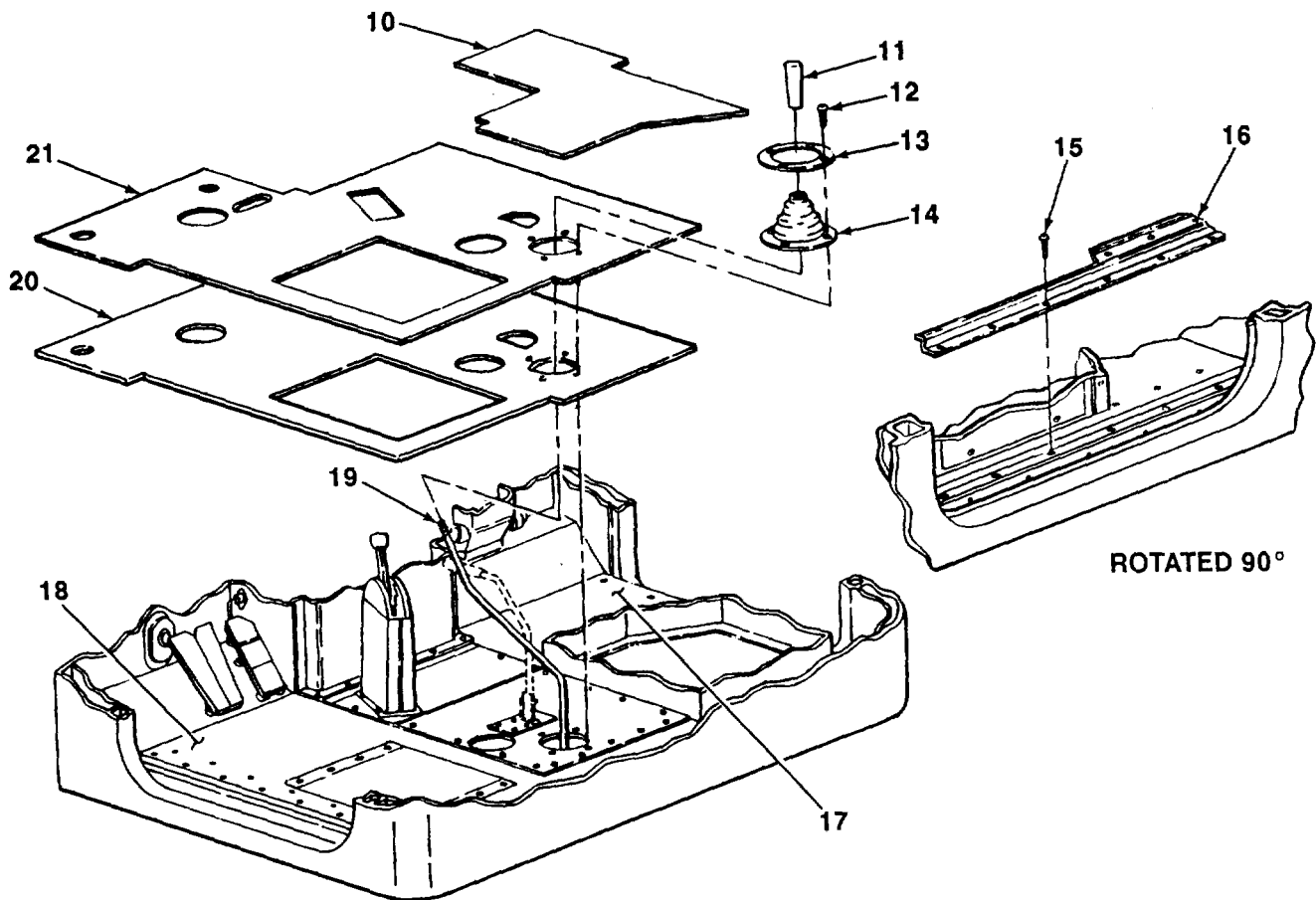
**b. INSTALLATION**

1. Install right side floormat (10) on right side floorboard (17).
2. Install scuff plate (16) on cab with nine screws (15).
3. Install insulation (20) and left side floormat (21) on left side floorboard (18).
4. Install new seal (14) and seal retainer (13) on left side floormat (21) and auxiliary transmission shift lever (19) with four screws (12). Install handle (11) on auxiliary transmission shift lever.

TA704119

15-2. FLOORMATS REPLACEMENT (Con't).

5. Install scuff plate (6) on cab with 14 screws (7).
6. Install lower rear molding (1) on rear cab wall (2) with three flatwashers (9) and screws (8).
7. Install lower rear molding (3) on rear cab wall (2) with six flatwashers (4) and screws (5).

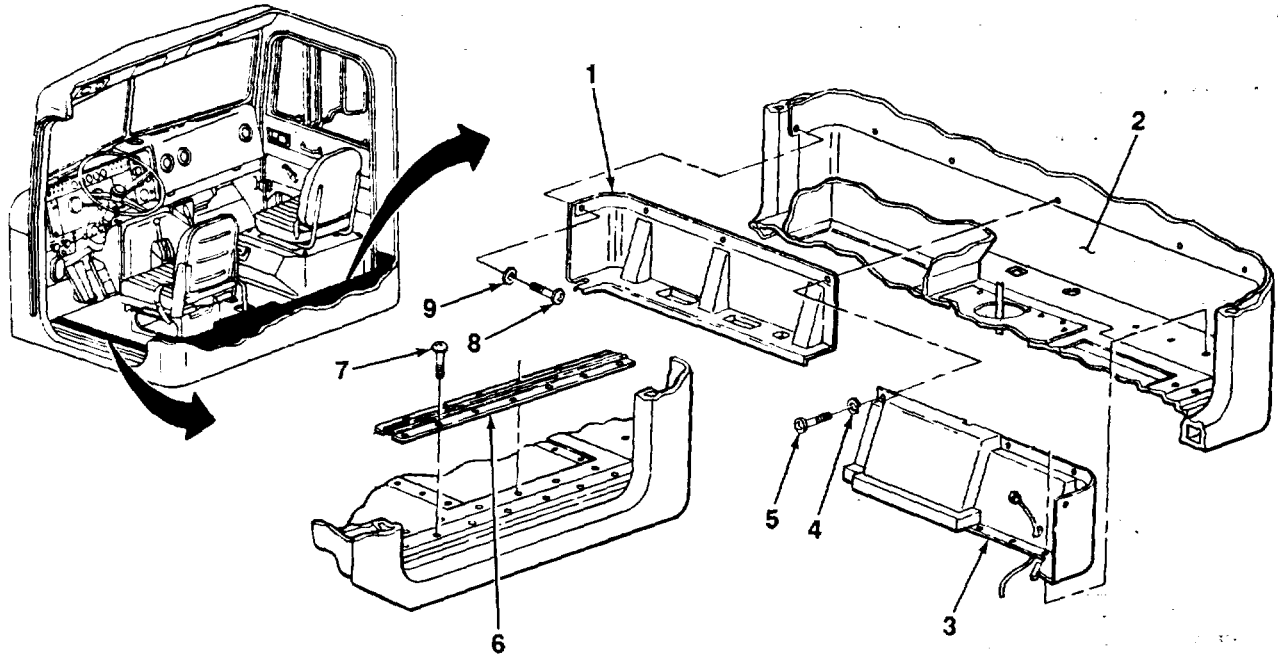

FOLLOW-ON TASKS:

- Install driver's seat (see TM 5-3805-254-20).

TA704120

15-3. FLOORBOARDS AND INSERTS REPLACEMENT.

This Task Covers:

- a. Removal
- b. Installation

Initial Setup:

Equipment Conditions:

- Engine cover removed (see paragraph 15-1).
- Four lockwashers

Materials/Parts:

- Two cotter pins

Tools/Test Equipment:

- General mechanic's tool kit

*** Four seals**

a. REMOVAL

1. Remove cotter pin (3), two flatwashers (2), clevis pin (5), and clevis (4) from dump body lift lever (1). Discard cotter pin.

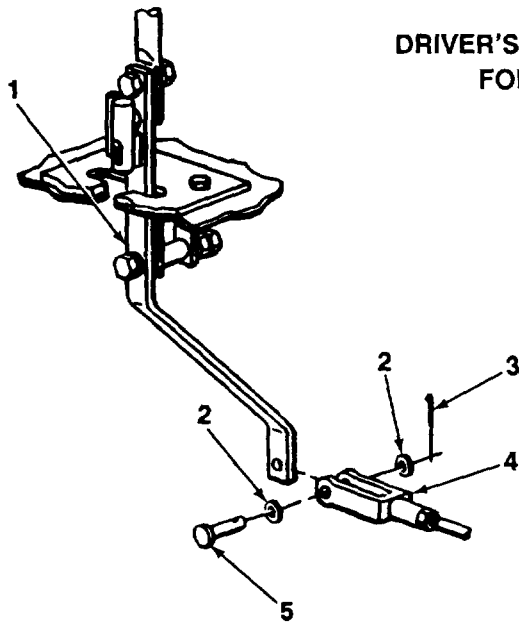

**DRIVER'S SEAT REMOVED
FOR CLARITY**

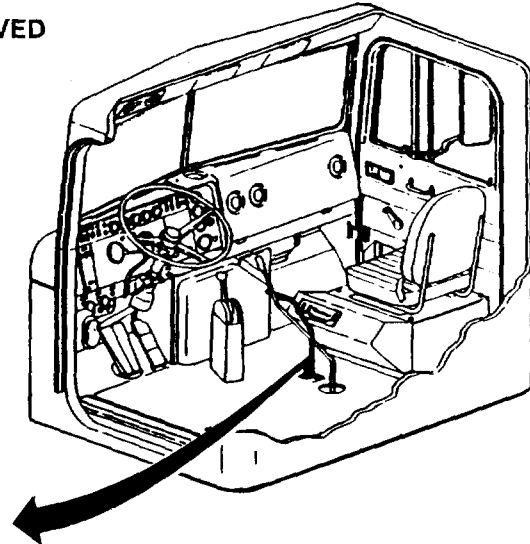

15-3. FLOORBOARDS AND INSERTS REPLACEMENT (Con't).

2. Remove two screws (12), lockwashers (13), spacers (7), and main transmission shift control cable (14) from bracket (6). Discard lockwashers.
3. Remove cotter pin (8), two flatwashers (11), and lower swivel (10) from shift control swivel lever (9). Discard cotter pin.

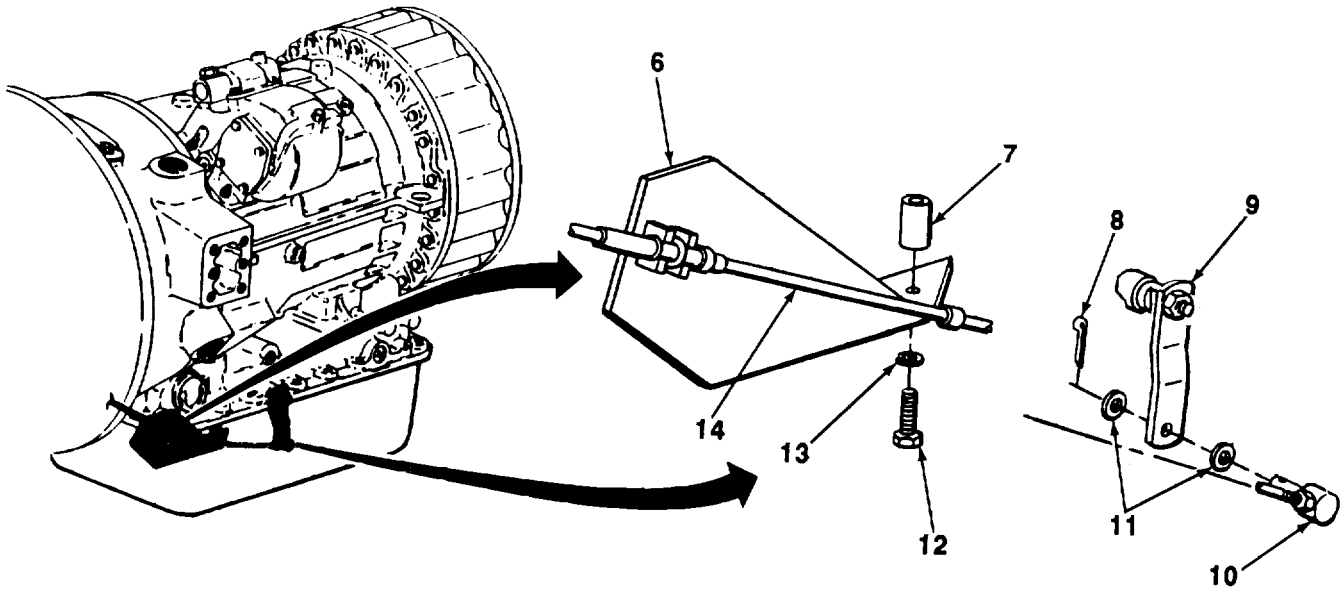

15-3. FLOORBOARDS AND INSERTS REPLACEMENT (Con't).

- 4. Remove handle (15) from auxiliary transmission shift lever (16).
- 5. Remove four screws (17), seal retainer (26), and seal (25) from floormat (24). Discard seal.
- 6. Remove two nuts (21), lockwashers (20), four flatwashers (19), two screws (23), and dump body lift handle (18) from lift linkage (22). Discard lockwashers.

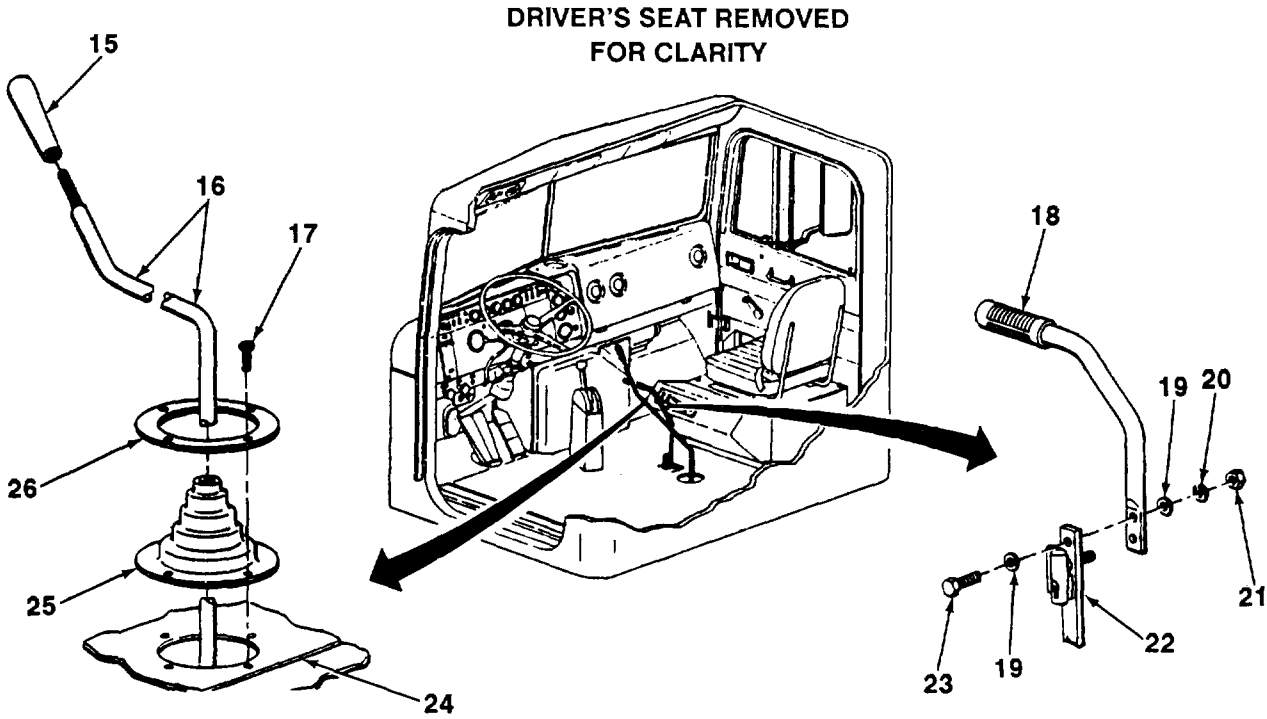

15-3. FLOORBOARDS AND INSERTS REPLACEMENT (Con't).

7. Move floormat (24) and insulation (29) to left.
8. Remove 15 screws (27) and flatwashers (28) from center floor cover plate (30).
9. Lift center floor cover plate (30) slightly and disconnect shift tower light (32).
10. Remove center floor cover plate (30) and three seals (31) from cab floor (33). Discard seals.

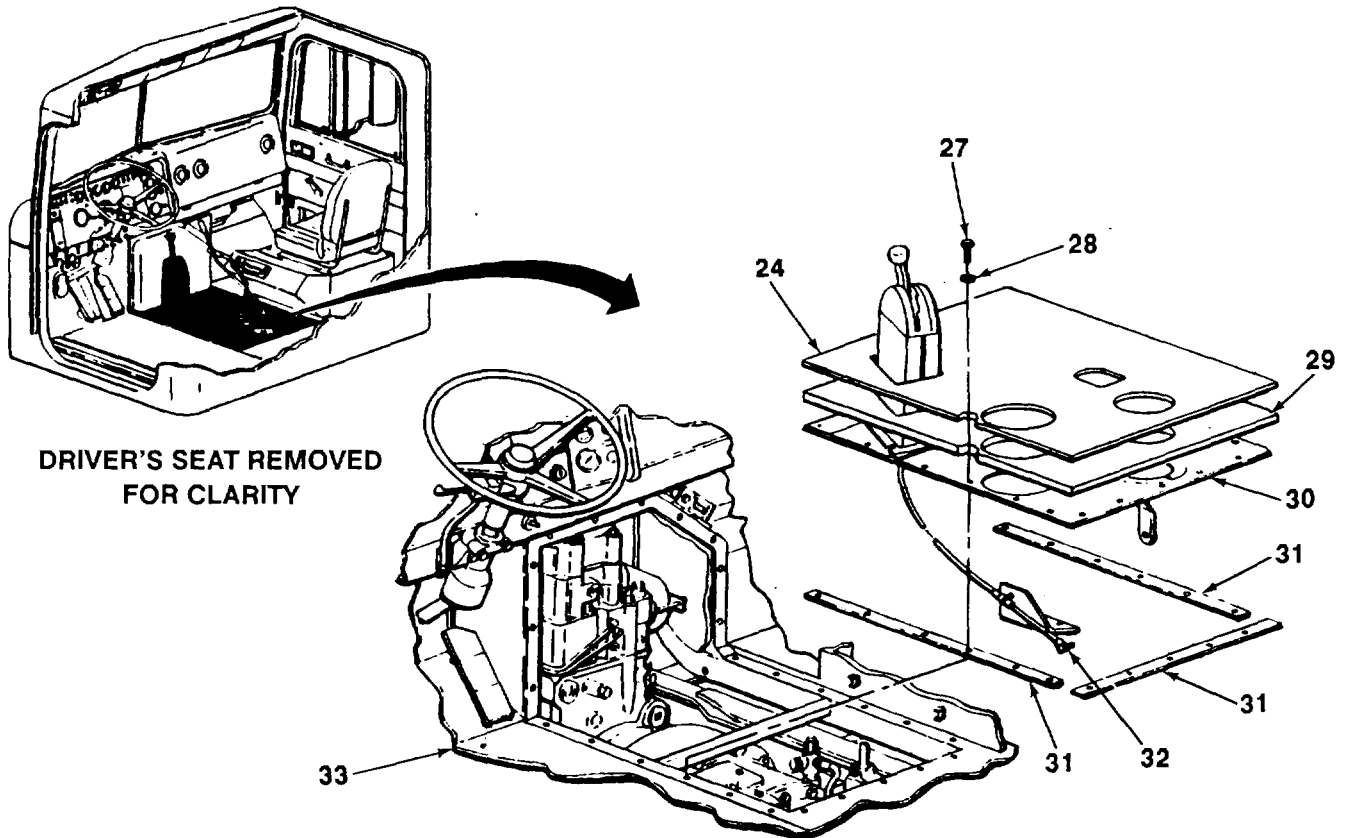
**b. INSTALLATION**

1. Position three new seals (31) and center floor cover plate (30) on cab floor (33). Lift cover up part way and connect shift tower light (32).
2. Install 15 flatwashers (28) and screws (27) on center floor cover plate (30) and three seals (31).
3. Move Insulation (29) and floormat (24) into position on center floor cover plate (30).

TA704124

15-3. FLOORBOARDS AND INSERTS REPLACEMENT (Con't).

- 4. Install new seal (25) and seal retainer (26) on auxiliary transmission shift lever (16) and floormat (24) with four screws (17).
- 5. Install handle (15) on auxiliary transmission shift lever (16).
- 6. Install dump body lift handle (18) on lift linkage (22) with two screws (23), four flatwashers (19), two new lockwashers (20), and nuts (21).

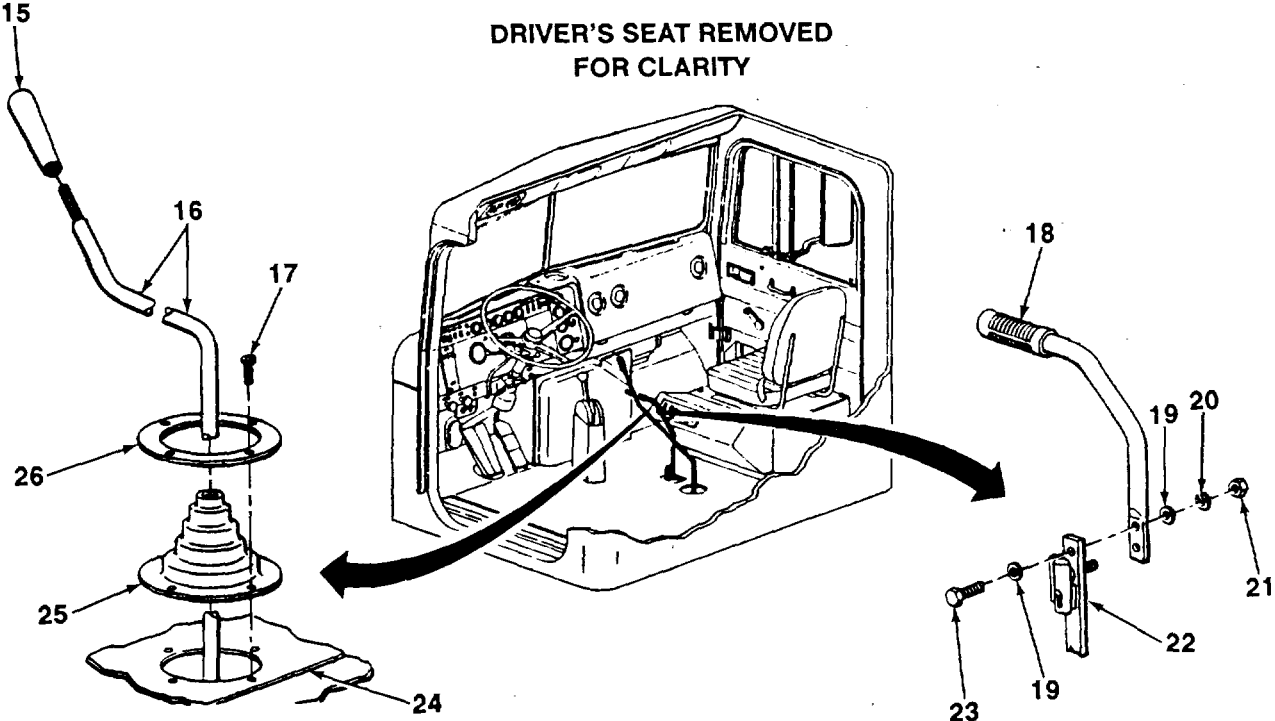

15-3. FLOORBOARDS AND INSERTS REPLACEMENT (Con't).

- 7. Install lower swivel (10) on shift control swivel lever (9) with two flatwashers (11) and new cotter pin (8).
- 8. Install main transmission shift control cable (14) on bracket (6) with two new lockwashers (13), screws (12), and spacers (7).

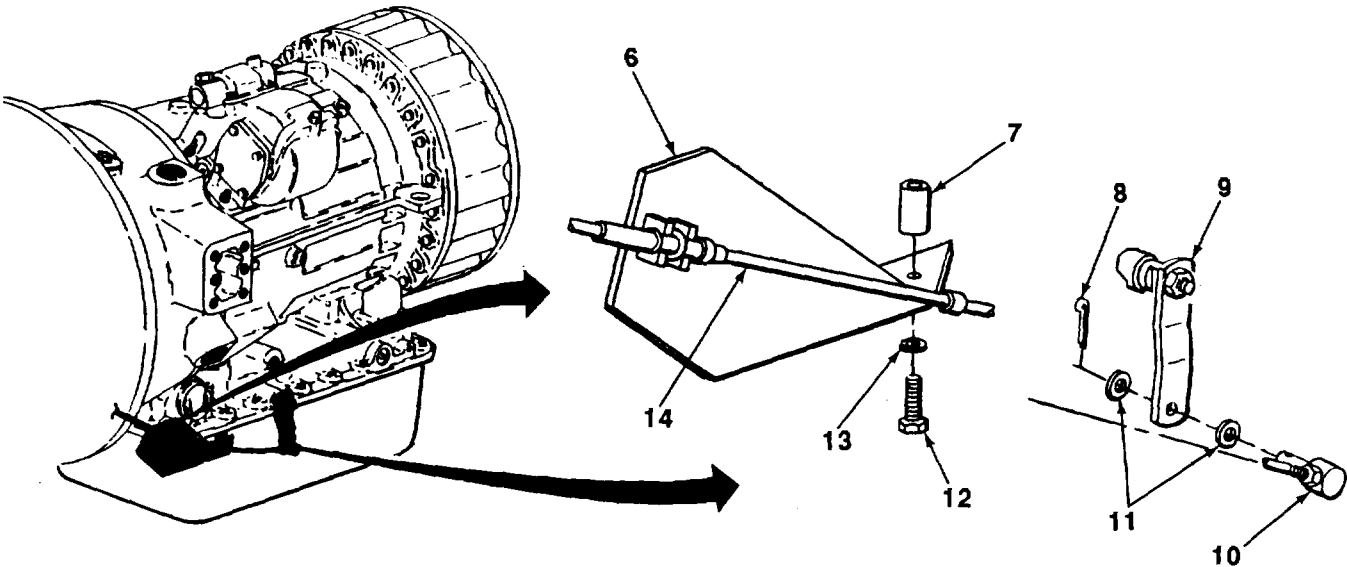

- 9. install clevis (4) on dump body lift lever (1) with two flatwashers (2), clevis pin (5), and new cotter pin (3).

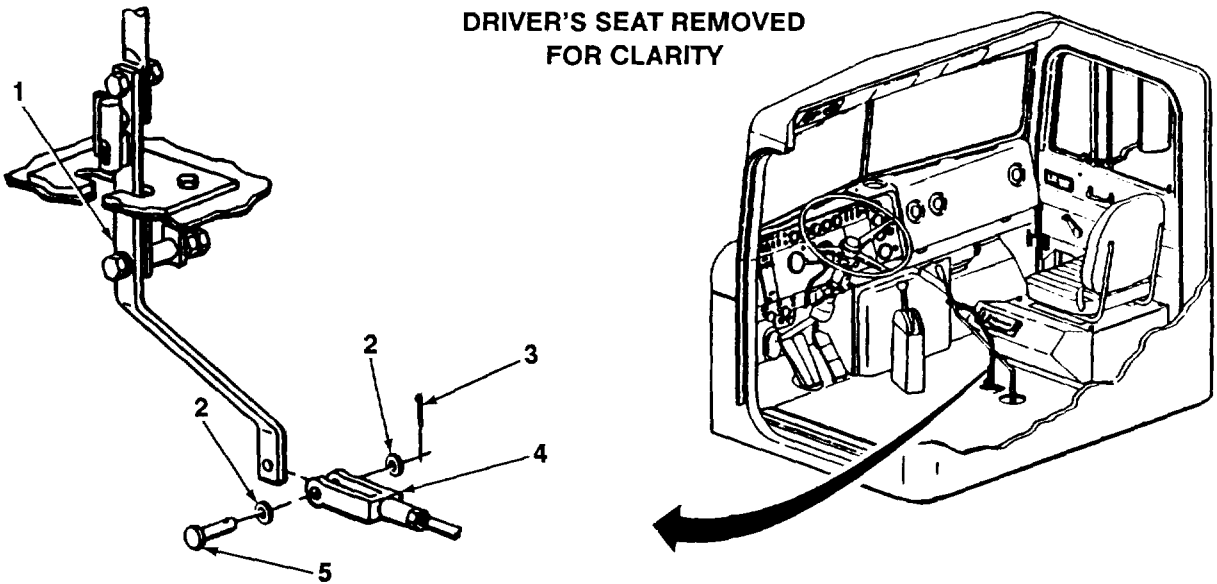

DRIVER'S SEAT REMOVED FOR CLARITY

FOLLOW-ON TASKS:

- Install engine cover (see paragraph 15-1).

15-4. CAB ASSEMBLY MAINTENANCE.

This Task Covers:

- | | |
|----------------|-----------------|
| a. Removal | c. Assembly |
| b. Disassembly | d. Installation |

Initial Setup:

Equipment Conditions:

- Dump body raised (see TM 5-3805-254-10).
- Preheater primer pump removed (see TM 5-3805-254-20).
- Preheater primer pump fuel lines and fittings removed (see TM 5-3805-254-20).
- Accelerator control pivot arm removed (see TM 5-3805-254-20).
- Accelerator control pedal removed (see TM 5-3805-254-20).
- Hand throttle control removed (see TM 5-3805-254-20).
- Exhaust diverter removed (see TM 5-3805-254-20).
- Muffler and raincap removed (see TM 5-3805-254-20).
- Left brake light switch removed (see TM 5-3805-254-20).
- Right brake light switch removed (see TM 5-3805-254-20).
- Low air pressure warning light switch removed (see TM 5-3805-254-20).
- Low air pressure warning buzzer switch removed (see TM 5-3805-254-20).
- Secondary magnetic switch removed (see TM 5-3805-254-20).
- Horn relay removed (see TM 5-3805-254-20).
- Low air pressure warning buzzer removed (see TM 5-3805-254-20).
- Turn signal and hazard flasher removed (see TM 5-3805-254-20).
- Alarm bell removed (see TM 5-3805-254-20).
- Domelight removed (see TM 5-3805-254-20).
- Engine compression brake 15 amp circuit breaker removed (see TM 5-3805-254-20).
- Backup light 20 amp circuit breaker removed (see TM 5-3805-254-20).
- Heater 40 amp circuit breaker removed (see TM 5-3805-254-20).
- Horn 20 amp circuit breaker removed (see TM 5-3805-254-20).
- Glow plug and cigar lighter 40 amp circuit breaker removed (see TM 5-3805-254-20).
- Stop and domelight 30 amp circuit breaker removed (see TM 5-3805-254-20).

Equipment Conditions (Con't):

- Tail and panel light 20 amp circuit breaker removed (see TM 5-3805-254-20).
- Headlight 20 amp circuit breaker removed (see TM 5-3805-254-20).
- Marker light 30 amp circuit breaker removed (see TM 5-3805-254-20).
- Fuse block removed (see TM 5-3805-254-20).
- Ignition system starter circuit breaker removed (see TM 5-3805-254-20).
- Center engine side of firewall junction box removed (see TM 5-3805-254-20).
- Right engine side of firewall junction box removed (see TM 5-3805-254-20).
- Left side of firewall junction box removed (see TM 5-3805-254-20).
- Front-rear of cab junction box removed (see TM 5-3805-254-20).
- Rear-rear of cab junction box removed (see TM 5-3805-254-20).
- Cab roof marker light and clearance light removed (see TM 5-3805-254-20).
- Automatic override module removed (see TM 5-3805-254-20).
- Transmission shift control stand removed (see TM 5-3805-254-20).
- Transmission shift cable removed (see TM 5-3805-254-20).
- Brake pedal removed (see TM 5-3805-254-20).
- Parking brake lines removed (see TM 5-3805-254-20).
- Cab floor through connector to double check valve hose removed (see TM 5-3805-254-20).
- Driver's seat removed (see TM 5-3805-254-20).
- Passenger's seat removed (see TM 5-3805-254-20).
- Heater core hoses removed (see TM 5-3805-254-20).
- Windshield wiper motor removed (see TM 5-3805-254-20).
- Air horn removed (see TM 5-3805-254-20).
- Air horn control valve removed (see TM 5-3805-254-20).
- Dump body control lever switch removed (see TM 5-3805-254-20).

15-4. CAB ASSEMBLY MAINTENANCE (Cc)**Equipment Conditions (Con't):**

- Air cleaner and brackets removed (see TM 5-3805-254-20).
- Air cleaner lines removed from firewall (see TM 5-3805-254-20).
- Oil filter removed (see TM 5-3805-254-20).
- Body and chassis wiring removed (see paragraph 5-6).
- Reverse polarity protection removed (see paragraph 5-6).
- Transmission cable hood removed (see paragraph 5-6).
- Floormats removed (see paragraph 15-2).
- Floorboards and Inserts removed (see paragraph 15-3).
- Cab doors and hinges removed (see paragraph 15-16).
- Heater box removed (see paragraph 15-35).
- Instrument panels removed (see paragraph 15-22).
- Instrument panel pad removed (see paragraph 15-21).
- Headlining removed (see paragraph 15-23).
- Coat hook removed (see paragraph 15-6).

Equipment Conditions (Con't):

- Windshield glass removed (see paragraph 15-25).
- Rear glass removed (see paragraph 15-26).
- Engine cover removed (see paragraph 15-1).
- Sunvisors removed (see paragraph 15-19).
- Cowl ventilator removed (see paragraph 15-11).
- Air intake duct removed (see paragraph 15-12).
- Cab door opening weatherseal removed (see paragraph 15-8).

Materials/Parts:

- Four lockwashers
- Ninety-seven rivets

Tools/Test Equipment:

- General mechanic's tool kit
- Field automotive shop set

References:

- TM 9-237

1. Remove two nuts (8), spacers (7), screws (1), four brackets (2 and 6), and bushings (3 and 5) from cab assembly (28) and bracket (4).
2. Remove four screws (17), flatwashers (18), and lockwashers (16) from upper mounting bracket (15). Discard lockwashers.
3. Remove two nuts (27), screws (14), flatwashers (13), rebound insulators (12), flatwashers (11), rebound insulators (10), and rebound retainers (9) from upper mounting bracket (15).

WARNING

Stand clear of lifting device when raising or lowering cab assembly. Failure to follow this warning may result in serious injury or death.

4. Using a suitable lifting device, carefully remove cab assembly (28) from frame.
5. Remove upper mounting bracket (15) and mounting insulator (19) from lower mounting bracket (21).
6. Remove four nuts (26), screws (20), and lower mounting bracket (21) from mounting crossmember (22).
7. If damaged, remove 12 nuts (23), screws (25), and mounting crossmember (22) from bracket (24).

15-4. CAB ASSEMBLY MAINTENANCE (Con't).

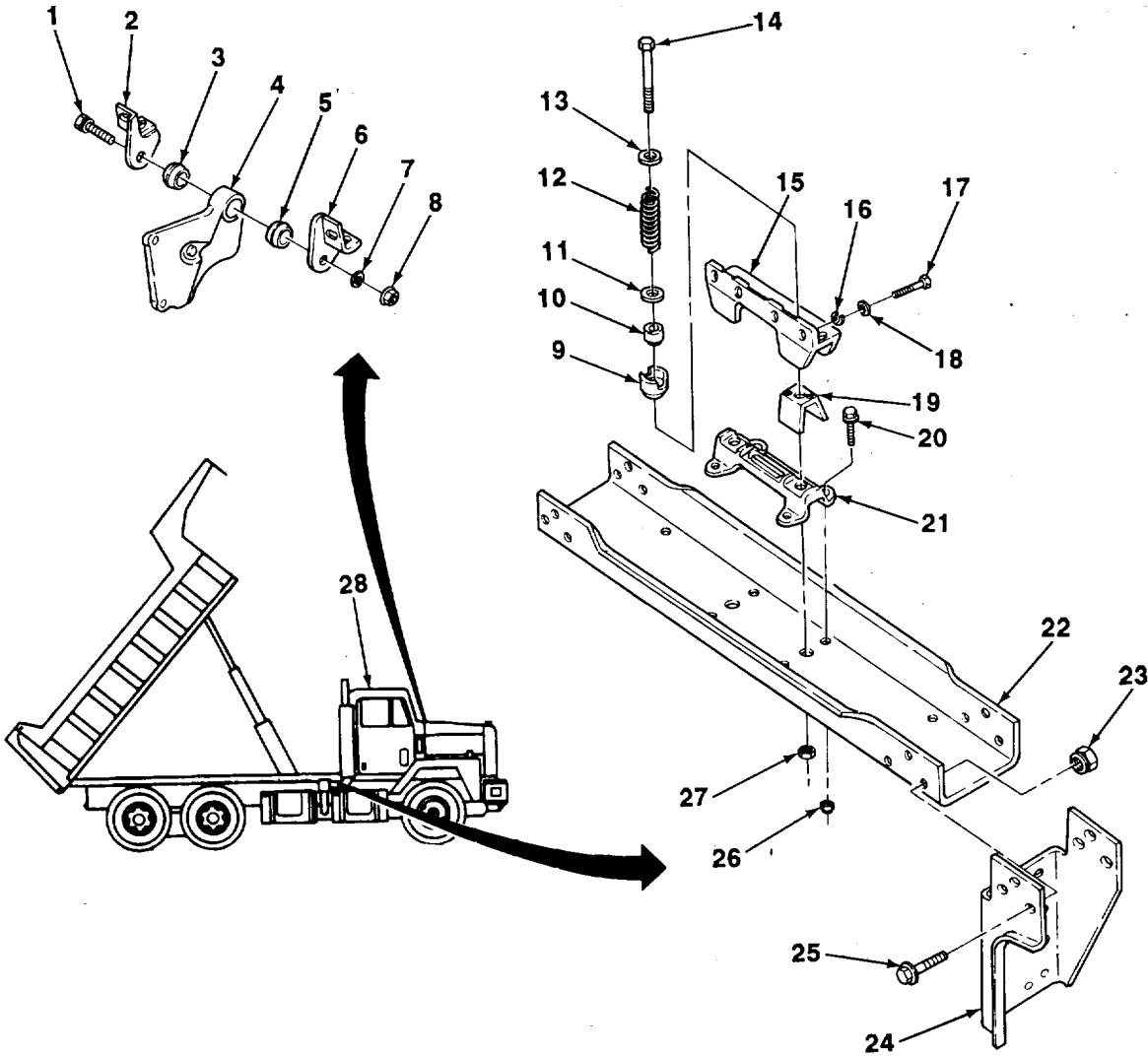

TA704127

15-4. CAB ASSEMBLY MAINTENANCE (Con't).**b. DISASSEMBLY**

1. Remove 36 rivets (32) and back panel (33) from cab (36). Discard rivets.
2. Remove 37 rivets (29) and cowl top panel (30) from cab (36). Discard rivets.

NOTE

Refer to TM 9-237 for Instructions on welding.

3. Cut welds and remove roof panel (31) from cab (36).
4. Remove 24 rivets (34) and two door opening panels (35). Discard rivets.

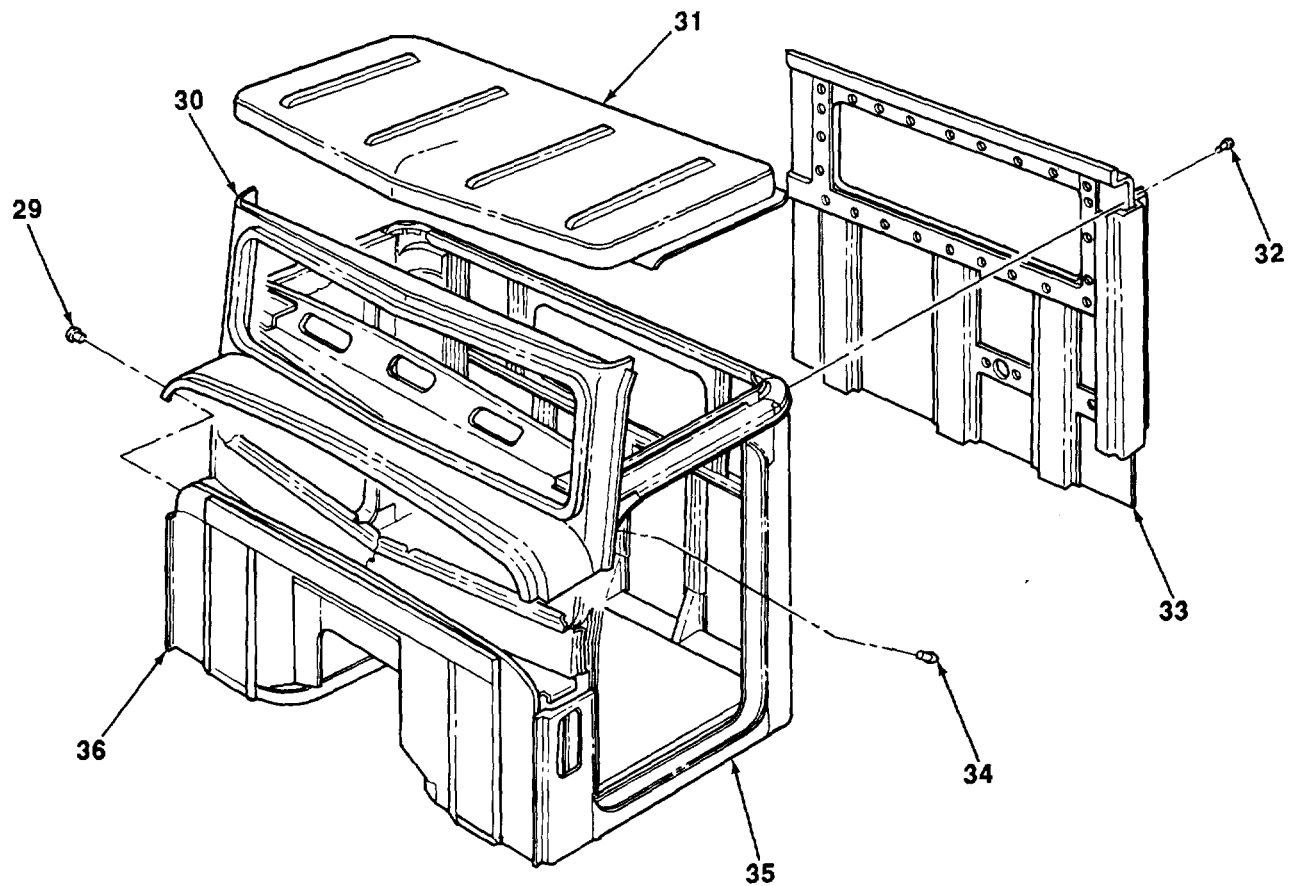
**c. ASSEMBLY**

1. Install two door opening panels (35) with 24 new rivets (34).
2. Position roof panel (31) on cab (36). Weld panel in place.
3. Install cowl top panel (30) on cab (36) with 37 new rivets (29).
4. Install back panel (33) on cab (36) with 36 new rivets (32).

TA704128

15-4. CAB ASSEMBLY MAINTENANCE (Con't).

d. INSTALLATION

1. If removed, install mounting crossmember (22) on bracket (24) with 12 screws (25) and nuts (26).
2. Install lower mounting bracket (21) on mounting crossmember (22) with four screws (20) and nuts (26).
3. Position mounting Insulator (19) and mounting bracket (15) on lower mounting bracket (21).

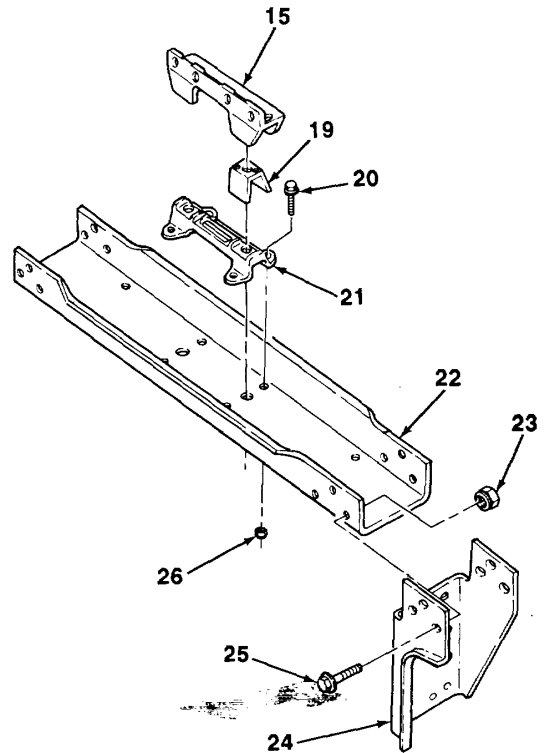

TA704129

15-4. CAB ASSEMBLY MAINTENANCE (Con't).**WARNING**

Stand clear of lifting device when raising or lowering cab assembly. Failure to follow this warning may result in serious injury or death.

4. Using a suitable lifting device, position cab assembly (28) on frame.
5. Install two rebound retainers (9), rebound insulators (10), flatwashers (11), rebound insulators (12), flatwashers (13), screws (14), and nuts (27) on upper mounting bracket (15).
6. Install four new lockwashers (16), flatwashers (18), and screws (17) on upper mounting bracket (15).
7. Install four bushings (3 and 5) and brackets (2 and 6) on cab assembly (28) and bracket (4) with two screws (1), spacers (7), and nuts (8).

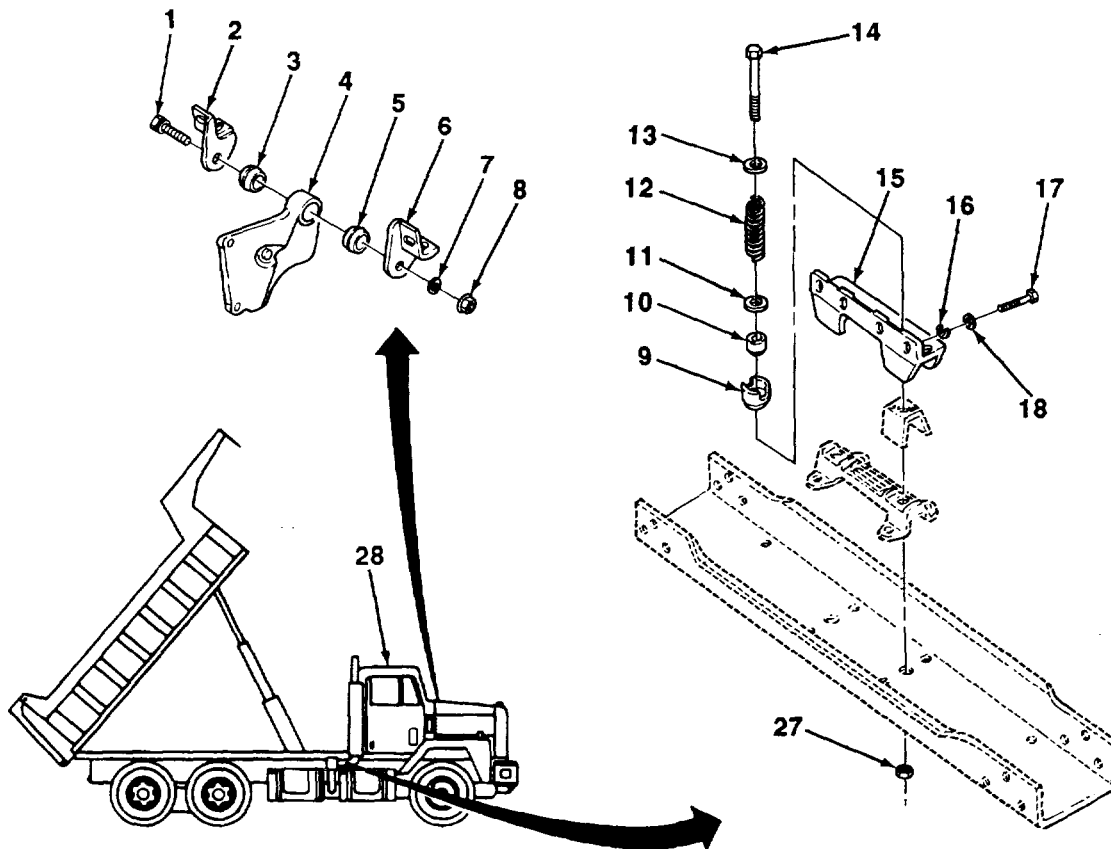

TA704130

15-4. CAB ASSEMBLY MAINTENANCE (Con't).

FOLLOW-ON TASKS:

- Install coat hook (see paragraph 15-6).
- Install cab door opening weatherseal (see paragraph 15-8).
- Install air intake duct (see paragraph 15-12).
- Install cowl ventilator (see paragraph 15-11).
- Install sunvisors (see paragraph 15-19).
- Install engine cover (see paragraph 15-1).
- Install rear glass (see paragraph 15-26).
- Install windshield glass (see paragraph 15-25).
- Install headlining (see paragraph 15-23).
- Install instrument panel pad (see paragraph 15-21).
- Install instrument panels (see paragraph 15-22).
- Install heater box (see paragraph 15-35).
- Install cab doors and hinges (see paragraph 15-16).
- Install floorboards and inserts (see paragraph 15-3).
- Install floor mats (see paragraph 15-2).
- Install transmission cable hood (see paragraph 5-6).
- Install reverse polarity protection (see paragraph 5-6).
- Install body and chassis wiring (see paragraph 5-6).
- Install oil filter (see TM 5-3805-254-20).
- Install air cleaner lines in firewall (see TM 5-3805-254-20).
- Install air cleaner and brackets (see TM 5-3805-254-20).
- Install dump body control lever switch (see TM 5-3805-254-20).
- Install air horn control valve (see TM 5-3805-254-20).
- Install air horn (see TM 5-3805-254-20).
- Install windshield wiper motor (see TM 5-3805-254-20).
- Install heater core hoses (see TM 5-3805-254-20).
- Install passenger's seat (see TM 5-3805-254-20).
- Install driver's seat (see TM 5-3805-254-20).
- Install cab floor through connector to double check valve hose (see TM 5-3805-254-20).
- Install parking brake lines (see TM 5-3805-254-20).
- Install brake pedal (see TM 5-3805-254-20).
- Install transmission shift cable (see TM 5-3805-254-20).
- Install transmission shift control stand (see TM 5-3805-254-20).
- Install automatic override module (see TM 5-3805-254-20).
- Install cab roof marker light and-clearance light (see TM 5-3805-254-20).
- Install rear-rear of cab junction box (see TM 5-3805-254-20).
- Install front-rear of cab junction box (see TM 5-3805-254-20).
- Install left side of firewall junction box (see TM 5-5805-254-20).
- Install right engine side of firewall junction box (see TM 5-3805-254-20).
- Install center engine side of firewall junction box (see TM 5-3805-254-20).
- Install ignition system starter circuit breaker (see TM 5-3805-254-20).
- Install fuse block (see TM 5-3805-254-20).
- Install marker light 30 amp circuit breaker (see TM 5-3805-254-20).
- Install headlight 20 amp circuit breaker (see TM 5-3805-254-20).
- Install tail and panel light 20 amp circuit breaker (see TM 5-3805-254-20).
- Install stop and domelight 30 amp circuit breaker (see TM 5-3805-254-20).
- Install glow plug and cigar lighter 40 amp circuit breaker (see TM 5-3805-254-20).
- Install horn 20 amp circuit breaker (see TM 5-3805-254-20).

15-4. CAB ASSEMBLY MAINTENANCE (Con't).

- Install heater 40 amp circuit breaker (see TM 5-3805-254-20).
- Install backup light 20 amp circuit breaker (see TM 5-3805-254-20).
- Install engine compression brake 15 amp circuit breaker (see TM 5-3805-254-20).
- Install domelight (see TM 5-3805-254-20).
- Install alarm bell (see TM 5-3805-254-20).
- Install turn signal and hazard flasher (see TM 5-3805-254-20).
- Install low air pressure warning buzzer (see TM 5-3805-254-20).
- Install horn relay (see TM 5-3805-254-20).
- Install secondary magnetic switch (see TM 5-3805-254-20).
- Install low air pressure warning buzzer switch (see TM 5-3805-254-20).
- Install low air pressure warning light switch (see TM 5-3805-254-20).
- Install right brake light switch (see TM 5-3805-254-20).
- Install left brake light switch (see TM 5-3805-254-20).
- Install muffler and raincap (see TM 5-3805-254-20).
- Install exhaust diverter (see TM 5-3805-254-20).
- Install hand throttle control (see TM 5-3805-254-20).
- Install accelerator control pedal (see TM 5-3805-254-20).
- Install accelerator control pivot arm (see TM 5-3805-254-20).
- Install preheater primer pump fuel lines and fittings (see TM 5-3805-254-20).
- Install preheater primer pump (see TM 5-3805-254-20).
- Lower dump body (see TM 5-3805-254-10).

15-5. CAB REAR TRIM REPLACEMENT.

This Task Covers:

- a. Removal b. Installation
-

Initial Setup:

Equipment Conditions:

- Rear window molding removed (see paragraph 15-7).
- Driver's seat removed (see TM 5-3805-254-20).
- Passenger's seat removed (see TM 5-3805-254-20).

Tools/Test Equipment:

- General mechanic's tool kit
-

a. REMOVAL

1. Remove eight screws (7), washers (6), and rear left molding (5) from rear cab wall (1).
2. Remove four screws (8), washers (9), and rear right molding (10) from rear cab wall (1).

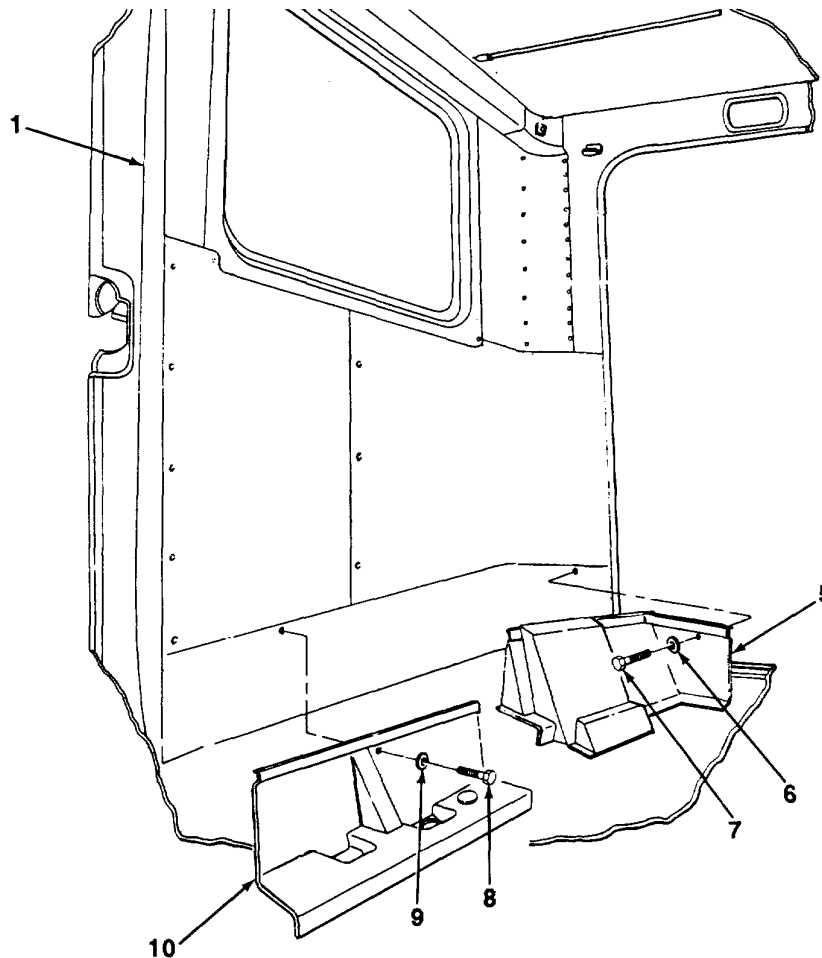

TA704131

15-5. CAB REAR TRIM REPLACEMENT (Con't).

- 3. Remove 22 screws (3), washers (2), and left panel (4) from rear cab wall (1).
- 4. Remove 17 screws (11), washers (12), and right panel (13) from rear cab wall (1).

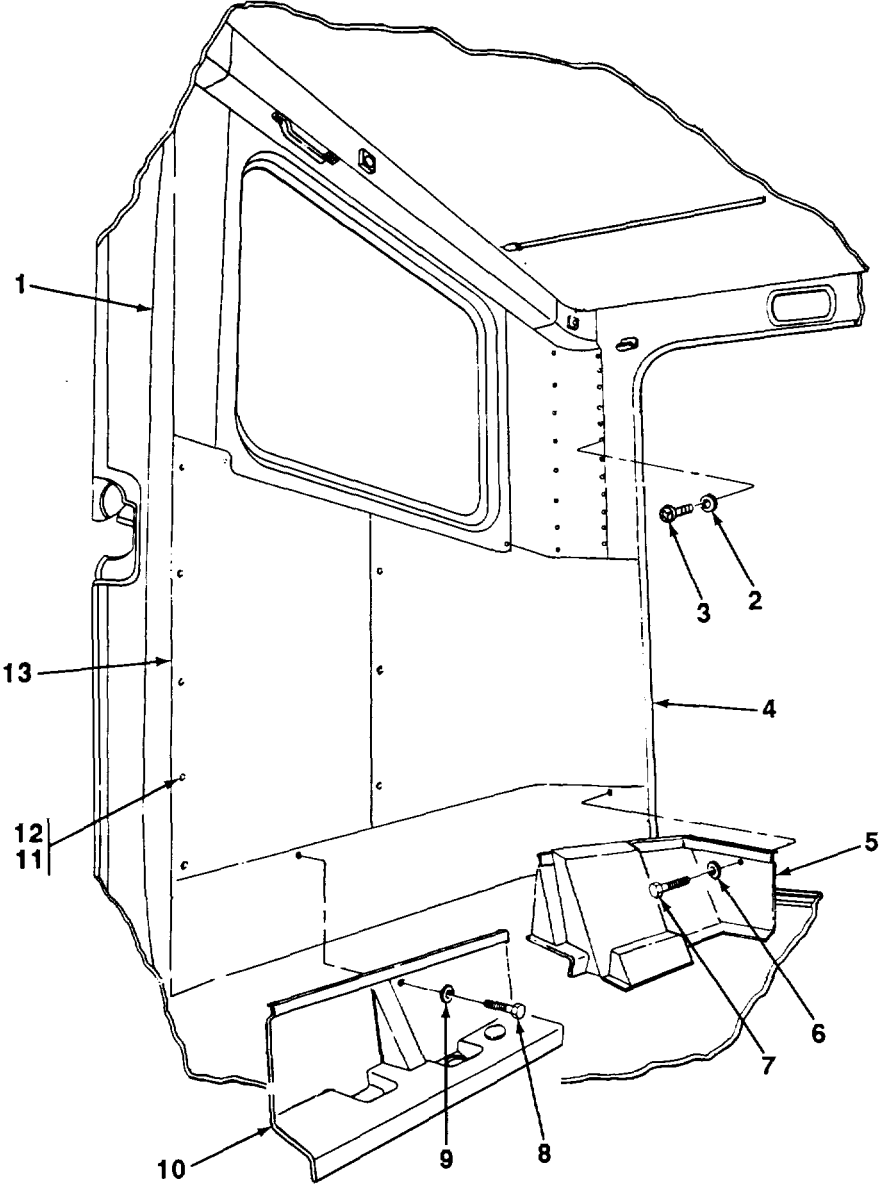

15-5. CAB REAR TRIM REPLACEMENT (Con't).

b. INSTALLATION

1. Install right panel (13) on rear cab wall (1) with 17 washers (12) and screws (11).
2. Install left panel (4) on rear cab wall (1) with 22 screws (3) and washers (2).
3. Install rear right molding (10) on rear cab wall (1) with four washers (9) and screws (8).
4. Install rear left molding (5) on rear cab wall (1) with eight washers (6) and screws (7).

FOLLOW-ON TASKS:

- Install passenger's seat (see TM 5-3805-254-20).
- Install driver's seat (see TM 5-3805-254-20).
- Install rear window molding (see paragraph 15-7).

15-6. COAT HOOK REPLACEMENT.

This Task Covers: Replacement

Initial Setup:

Tools/Test Equipment:

- General mechanic's tool kit
-

REPLACEMENT

1. Remove screw (3) and coat hook (2) from panel retainer (1).
2. Install coat hook (2) on panel retainer (1) with screw (3).

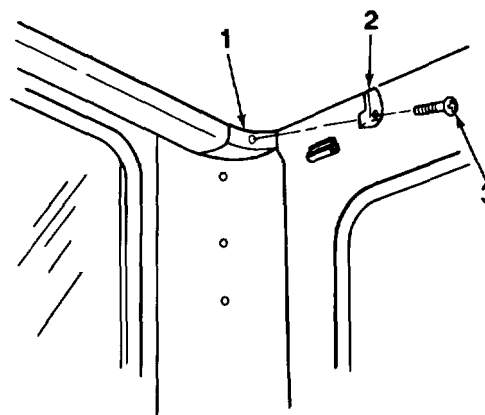

TA704133

15-7. REAR WINDOW MOLDING REPLACEMENT.

This Task Covers: Replacement

Initial Setup:

Tools/Test Equipment:

- General mechanic's tool kit
-

REPLACEMENT

1. Remove 24 screws (4), washers (3), and molding (2) from rear cab wall (1).
2. Install molding (2) on rear cab wall (1) with 24 washers (3) and screws (4).

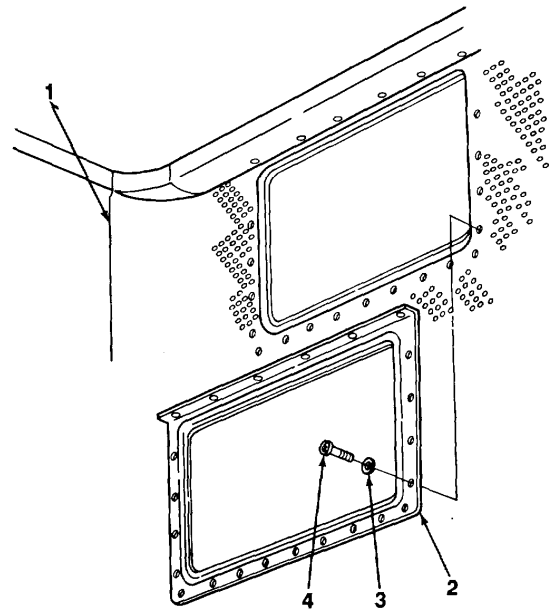

TA704134

15-8. CAB DOOR OPENING WEATHERSEAL REPLACEMENT (Con't).

3. Remove seven screws (6) and retainer (5) from floor panel (7).
4. Remove lower weatherseal (4) from floor panel (7). Discard weatherseal.
5. Clean all traces of rubber cement and weatherseal (4) from cab door opening (1) and floor panel (7)

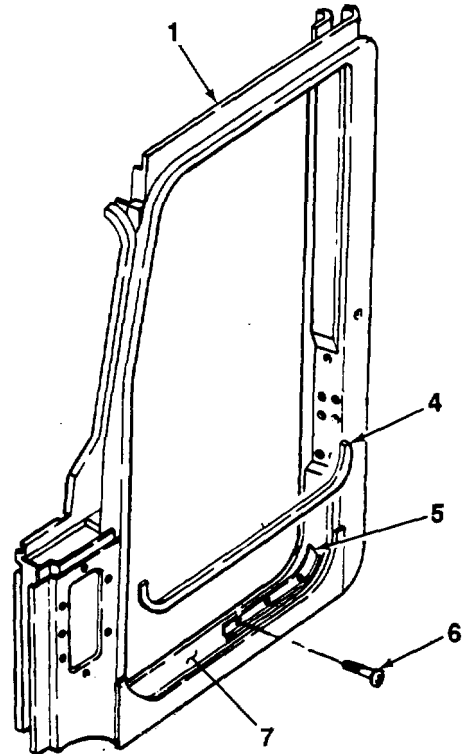
**b. INSTALLATION**

1. Coat molding (2) with rubber cement and press new weatherseal (3) into place on molding.
2. Install molding (2) on cab door opening (1).
3. Coat floor panel (7) with rubber cement and press new lower weatherseal (4) into place on floor panel.
4. Wipe cab door opening (1) and floor panel (7) free of excess rubber cement.
5. Install retainer (5) on floor panel (7) with seven screws (6).

TA704136

15-9. DOOR CHECK REPLACEMENT.

This Task Covers: Replacement

Initial Setup:

Materials/Parts:

- Four lockwashers

Tools/Test Equipment:

- General mechanic's tool kit
-

REPLACEMENT

1. Remove four screws (5), lockwashers (4), and door check (3) from cab door (1) and cab (2). Discard lockwashers.
2. Install door check (3) on cab door (1) and cab (2) with four new lockwashers (4) and screws (5).

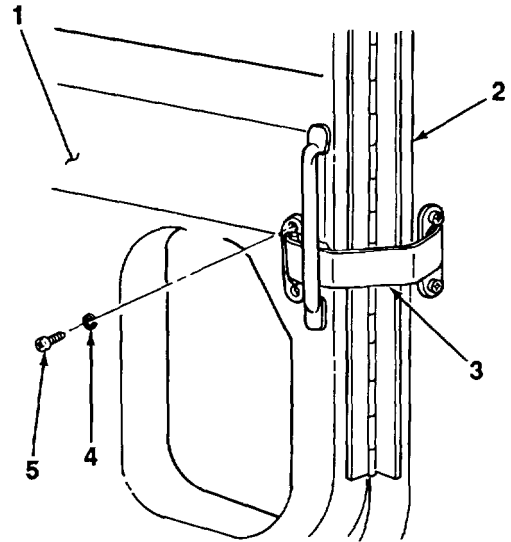

TA704137

15-10. DOVETAIL REPLACEMENT.

This Task Covers:

- a. Removal b. Installation
-

Initial Setup:

Tools/Test Equipment:

- General mechanic's tool kit
-

a. REMOVAL

1. Remove four screws (1), dovetail (2), and spacer (3) from cab door frame (4).
2. Remove two screws (7) and door plate (6) from cab door (5).

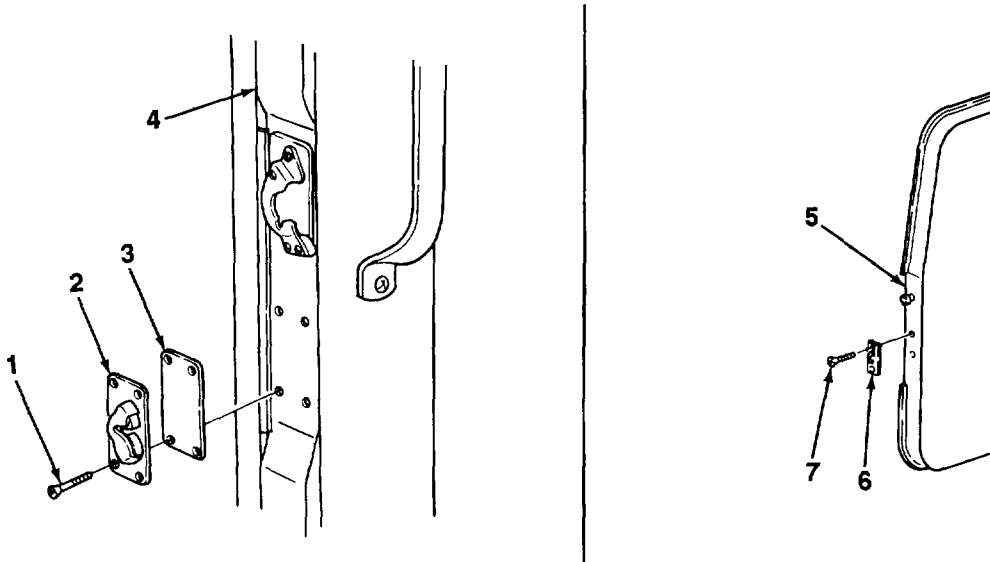
**b. INSTALLATION**

1. Install door plate (6) on cab door (5) with two screws (7).
2. Install spacer (3) and dovetail (2) on cab door frame (4) with four screws (1).

TA704138

15-11. COWL VENTILATOR REPLACEMENT.

This Task Covers:

a. Removal

b. Installation

Initial Setup:

Materials/Parts:

- Twelve rivets

Tools/Test Equipment:

- Field automotive shop set
-

a. REMOVAL

1. Remove 12 rivets (4) and cowl ventilator (2) from cab (3). Discard rivets.
2. If damaged, remove knob (1) from cowl ventilator (2).

b. INSTALLATION

1. If removed, install knob (1) on cowl ventilator (2)
2. Install cowl ventilator (2) on cab (3) with 12 new rivets (4).

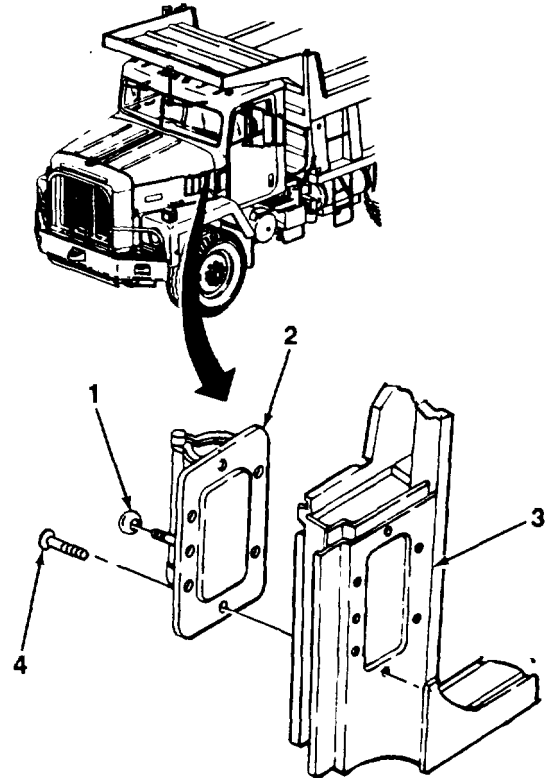

TA704139

15-12. AIR INTAKE DUCT REPLACEMENT.

This Task Covers: Replacement

Initial Setup:

Tools/Test Equipment:

- General mechanic's tool kit
-

REPLACEMENT

1. Remove seven screws (1) and air intake duct (3) from cab (2).
2. Install air intake duct (3) on cab (2) with seven screws (1).

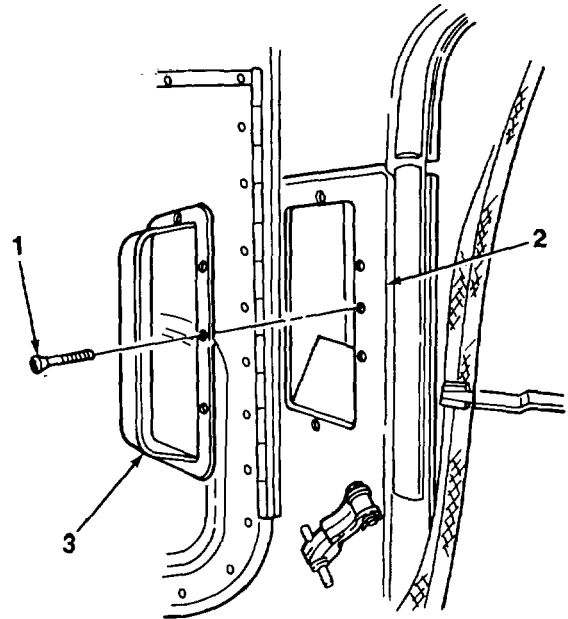

TA704140

15-13. CAB DOOR PANELS REPLACEMENT.

This Task Covers:

- | | |
|-----------------------------|-----------------------------|
| a. Upper Panel Removal | c. Lower Panel Removal |
| b. Upper Panel Installation | d. Lower Panel Installation |

Initial Setup:

Equipment Conditions:

- Window glass completely raised.

Tools/Test Equipment:

- General mechanic's tool kit

Materials/Parts:

- Six lockwashers (lower panel replacement)
- Sixteen lockwashers (upper panel replacement)

Personnel Required: Two

a. UPPER PANEL REMOVAL

1. Remove knob (3) and bushing (4) from upper panel (5).
2. Remove two screws (7) and pad (6) from upper panel (5).

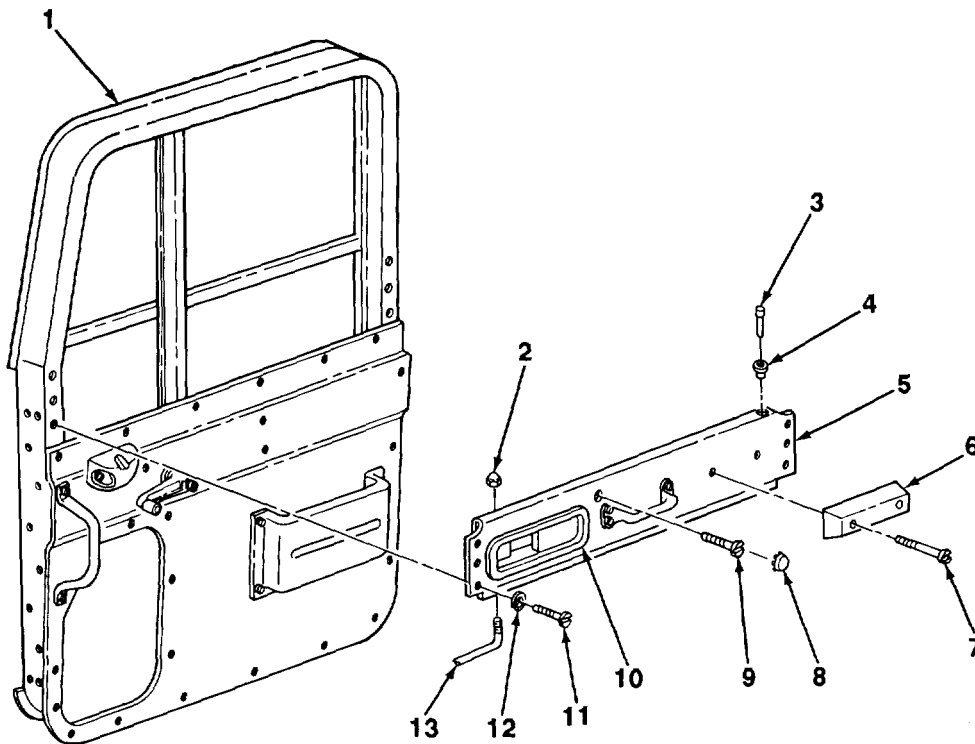

TA704141

15-13. CAB DOOR PANELS REPLACEMENT (Con't).**NOTE****Do not drop screws in door when installing screws.**

3. Remove cap (8) and screw (9) from upper panel (5).
4. Remove 12 screws (11) and lockwashers (12) from upper panel (5). Discard lockwashers.
5. Move upper panel (5) away from cab door. Remove retainer (2) and rod (13) from door handle (10).
6. Remove upper panel (5) from cab door (1).
7. Remove two nuts (19) and door handle (10) from upper panel (5).
8. Remove four screws (15), lockwashers (16), washers (17), nuts (14), and handle (18) from upper panel (5). Discard lockwashers.

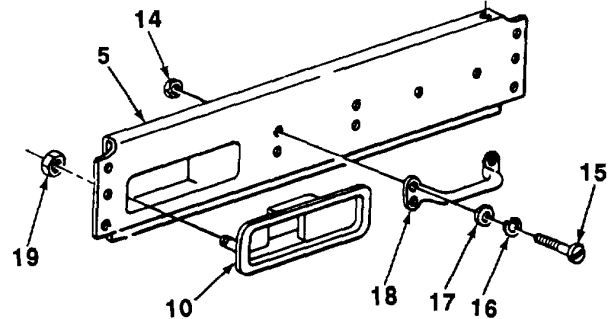
**b. UPPER PANEL INSTALLATION**

1. Install handle (18) on upper panel (5) with four nuts (14), washers (17), new lockwashers (16), and screws (15).
2. Install door handle (10) on upper panel (5) with two nuts (19).
3. Install rod (13) on door handle (10) with retainer (2). 4. Install upper panel (5) on cab door (1) with 12 new lockwashers (12) and screws (11).

NOTE**Do not drop screw in door when installing screw.**

5. Install screw (9) and cap (8) on upper panel (5).
6. Install pad (6) on upper panel (5) with two screws (7).
7. Install bushing (4) and knob (3) on upper panel (5).

TA704142

15-13. CAB DOOR PANELS REPLACEMENT**c. LOWER PANEL REMOVAL**

1. Remove screw (23), window regulator hand (22), and washer (21) from lower panel (20).
2. Remove four screws (25), lockwashers (26), and door pocket (24) from lower panel (20). Discard lockwashers.
3. Remove two screws (27), washers (28), and grab handle (29) from lower panel (20).
4. Remove two screws (30) and ashtray (31) from lower panel (20).

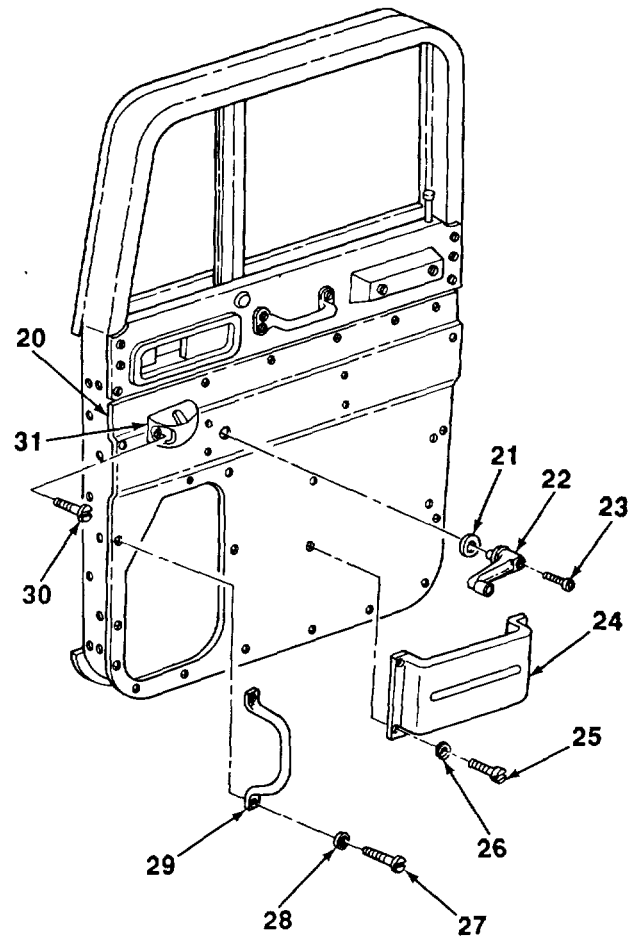

5. Remove two screws (33), lockwashers (34), and door check (35) from lower panel (20). Do not discard lockwashers.
6. Remove 22 screws (32) and lower panel (20) from cab door (1).

NOTE

To avoid damage to door when fully open, door check must be installed.

7. Install door check (35) on cab door (1) with two original lockwashers (34) and screws (33).

TA704143

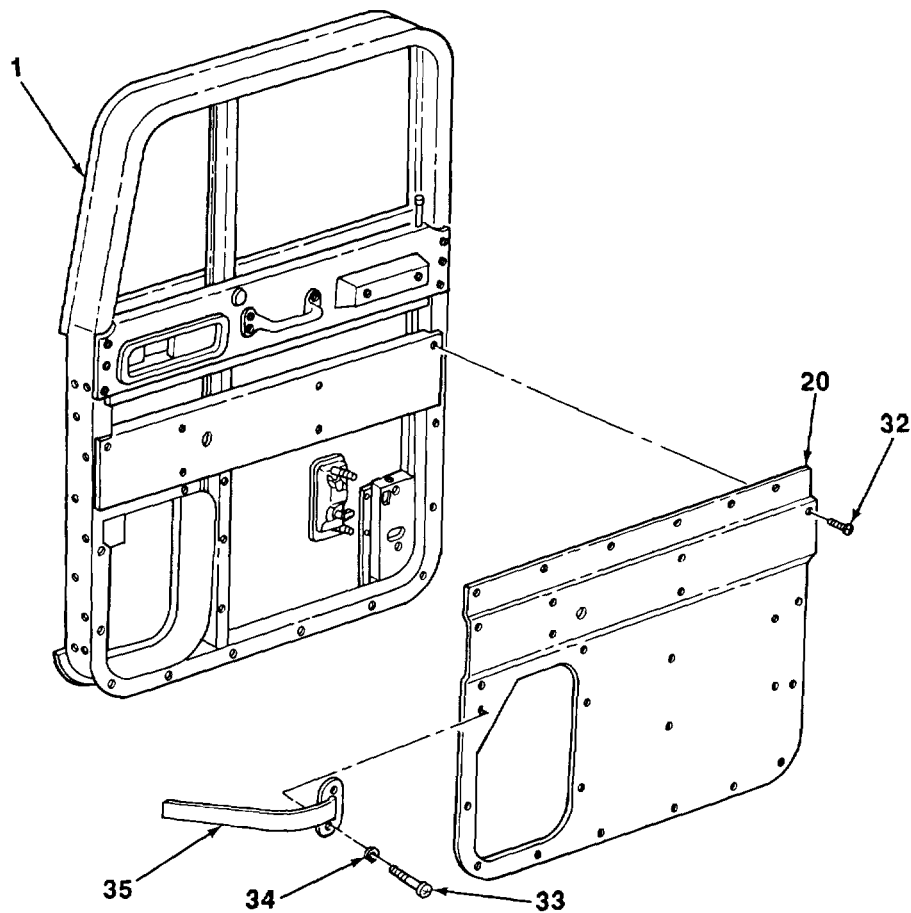
15-13. CAB DOOR PANELS REPLACEMENT (Con't).**d. LOWER PANEL INSTALLATION**

1. Remove two screws (33), lockwashers (34), and door check (35) from cab door (1). Discard lockwashers.
2. Install lower panel (20) on cab door (1) with 22 screws (32).
3. Install door check (35) on lower panel (20) with two new lockwashers (34) and screws (33).
4. Install ashtray (31) on lower panel (20) with two screws (30).
5. Install grab handle (29) on lower panel (20) with two washers (28) and screws (27).
6. Install door pocket (24) on door panel (20) with four new lockwashers (26) and screws (25).
7. Install washer (21) and window regulator handle (22) on door panel (20) with screw (23).

TA704144

15-14. CAB DOOR HANDLES REPLACEMENT.

This Task Covers:

- | | |
|-------------------------------------|------------------------------------|
| a. Outside Door Handle Removal | c. Inside Door Handle Removal |
| b. Outside Door Handle Installation | d. Inside Door Handle Installation |

Initial Setup:

Equipment Conditions:

- Cab door lower panel removed (outside door handle replacement) (see paragraph 15-13).
- Cab door upper panel removed (inside door handle replacement) (see paragraph 15-13).

Tools/Test Equipment:

- General mechanic's tool kit

a. OUTSIDE DOOR HANDLE REMOVAL

1. Remove retainers (2) and remote control rods (4) from door handle (3).
2. Remove two nuts (5) and door handle (3) from cab door (1).

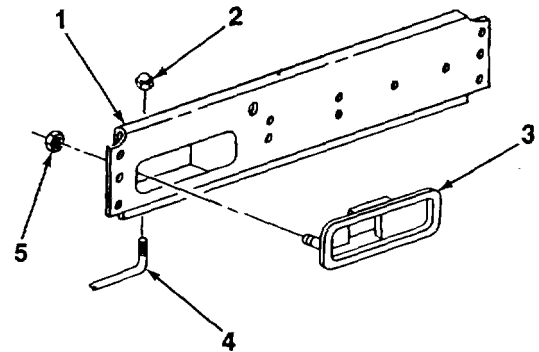
**b. OUTSIDE DOOR HANDLE INSTALLATION**

1. Install door handle (3) on cab door (1) with two nuts
2. Install remote control rod (4) on door handle (3) with retainer

TA704145

15-14. CAB DOOR HANDLES REPLACEMENT (Con't).**c. INSIDE DOOR HANDLE REMOVAL**

1. Remove two retainers (7) and remote control rods (8) from door handle (6).
2. Remove two nuts (9) and door handle (6) from cab door (1).

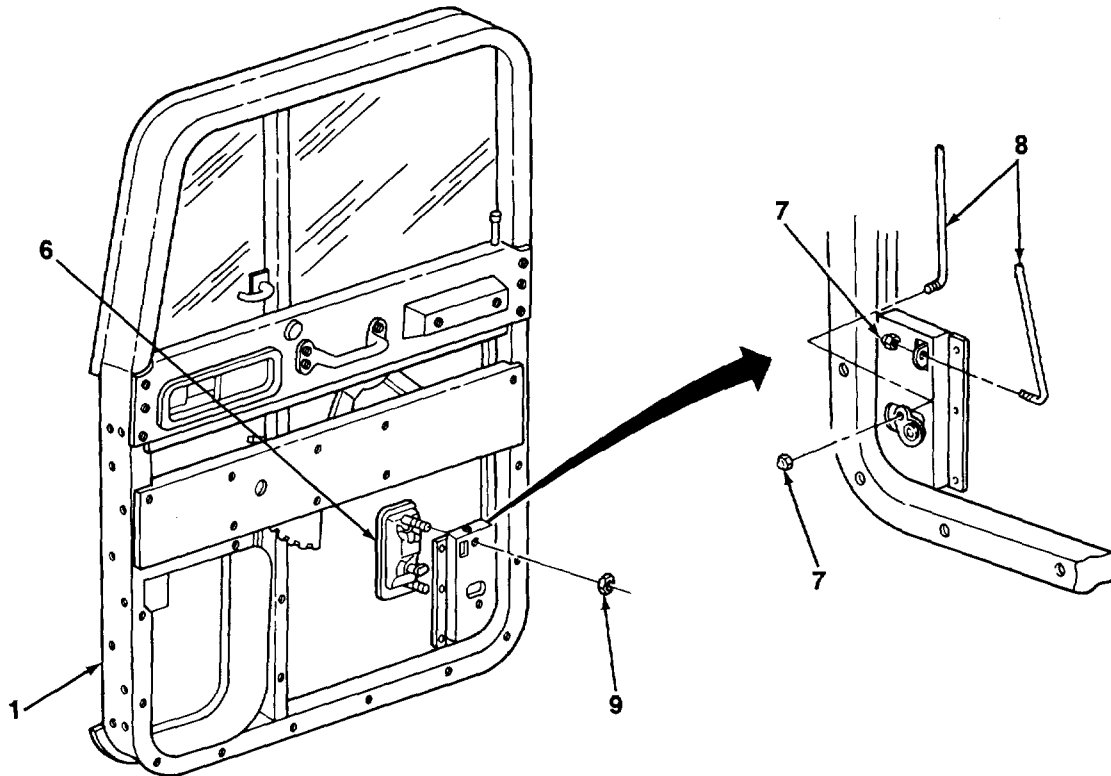
**d. INSIDE DOOR HANDLE INSTALLATION**

1. Install door handle (6) on cab door (1) with two nuts (9).
2. Install remote control rods (8) on door handle (6) with two retainers (7).

FOLLOW-ON TASKS:

- Install cab door upper panel (inside door handle replacement) (see paragraph 15-13).
- Install cab door lower panel (outside door handle replacement) (see paragraph 15-13).

TA704146

15-15. CAB DOOR GLASS AND WINDOW REGULATOR REPLACEMENT (Con't).

- 6. Remove door glass channel (3) and seal (11) from door glass (2). Discard seal.
- 7. Remove channel (10) from door glass (2).

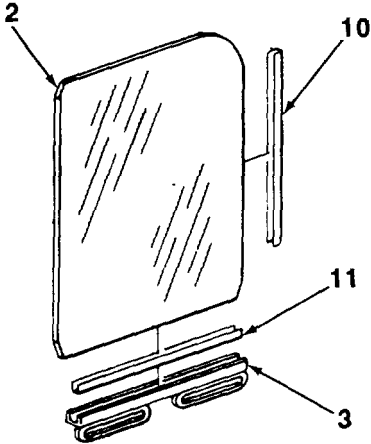

NOTE
Perform step 8 only if replacing window regulator.

- 8. Remove four screws (12) and window regulator (4) from cab door (1).

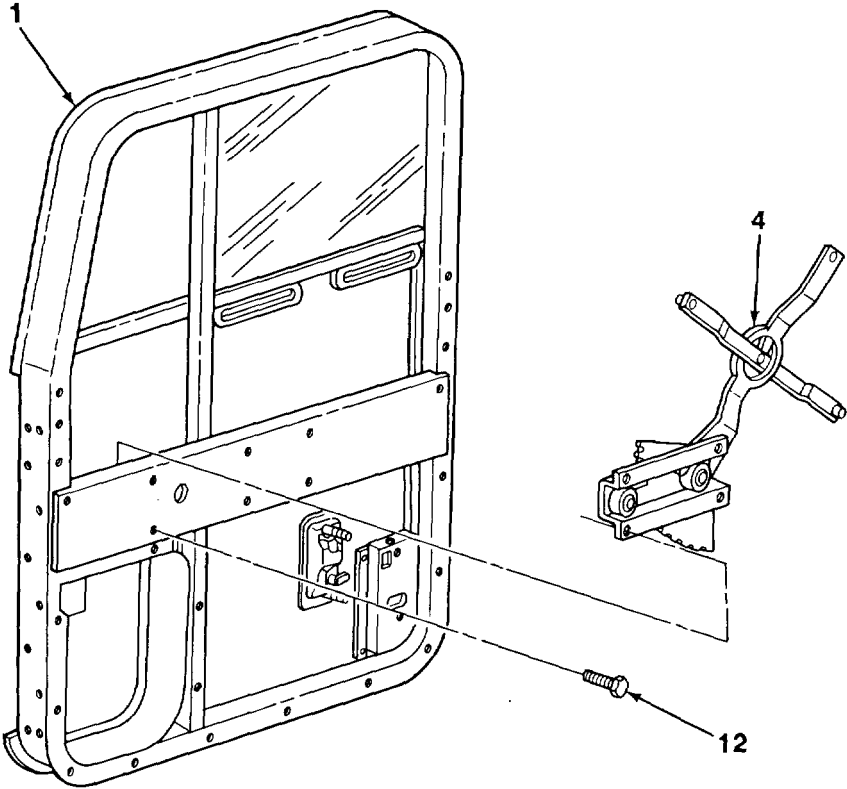

15-15. CAB DOOR GLASS AND WINDOW REGULATOR REPLACEMENT (Con't).

b. INSTALLATION

NOTE

- If Installing window regulator only, perform steps 1 and 5.
- Perform step 1 only if window regulator was removed.

1. Install window regulator (4) on cab door (1) with four screws (12).

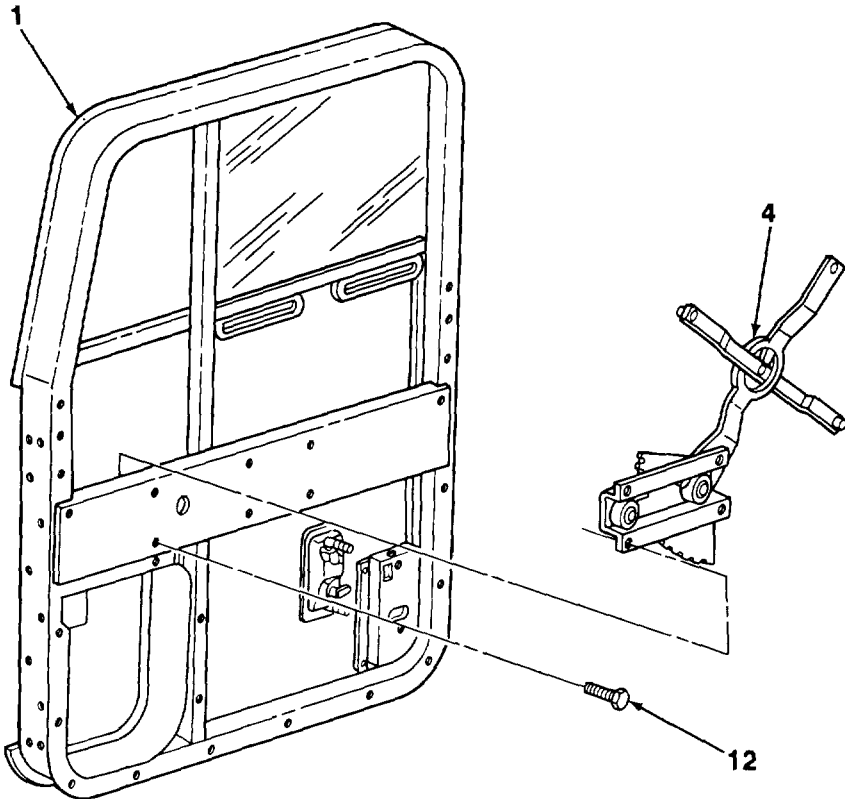

15-15. CAB DOOR GLASS AND WINDOW REGULATOR REPLACEMENT (Con't).

2. Install channel (10) on door glass (2).
3. Install new seal (11) and door glass channel (3) on door glass (2).
4. Position door glass (2) on cab door (1).
5. Position window regulator (4) on door glass channel (3) and Install two retainer clips (9).
6. If removed, install bracket (7) on cab door (1) with two screws (6).
7. Install screw (5) on window channel (8) and bracket (7).

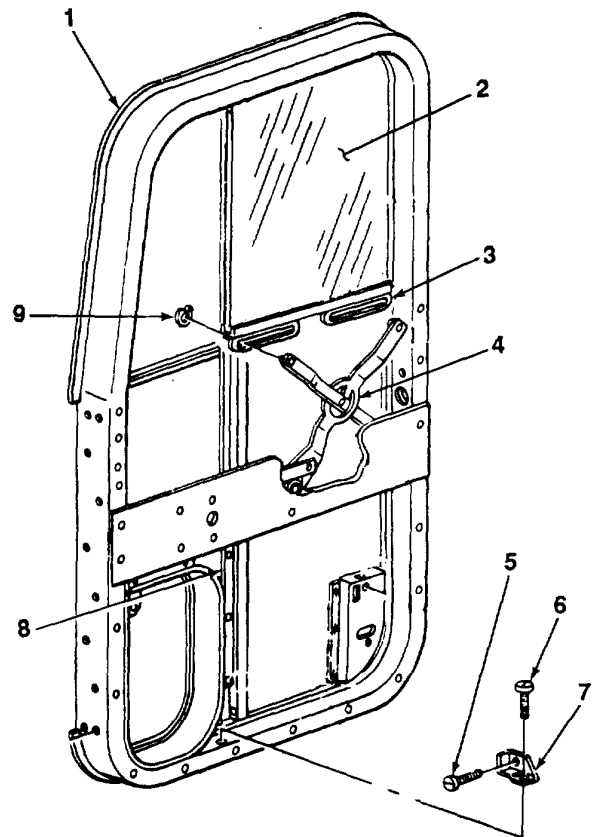
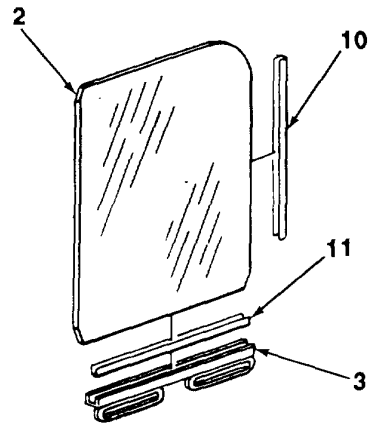

FOLLOW-ON TASKS:

- Install cab door upper and lower panels (see paragraph 15-13).

TA704150

15-16. CAB DOOR AND HINGE REPLACEMENT.

This Task Covers:

a. Removal

b. Installation

Initial Setup:

Equipment Conditions:

- Window glass completely raised.

Materials/Parts:

- Two lockwashers

Tools/Test Equipment:

- General mechanic's tool kit

References:

- TM 5-3805-254-20

Personnel Required: Two**a. REMOVAL**

1. Remove two screws (3), lockwashers (2), and door check (4) from cab door (1). Discard lockwashers.
2. Have assistant support cab door (1). Remove ten screws (5) and cab door from hinge (6).
3. If damaged, remove nine screws (7) and hinge (6) from cab (8).

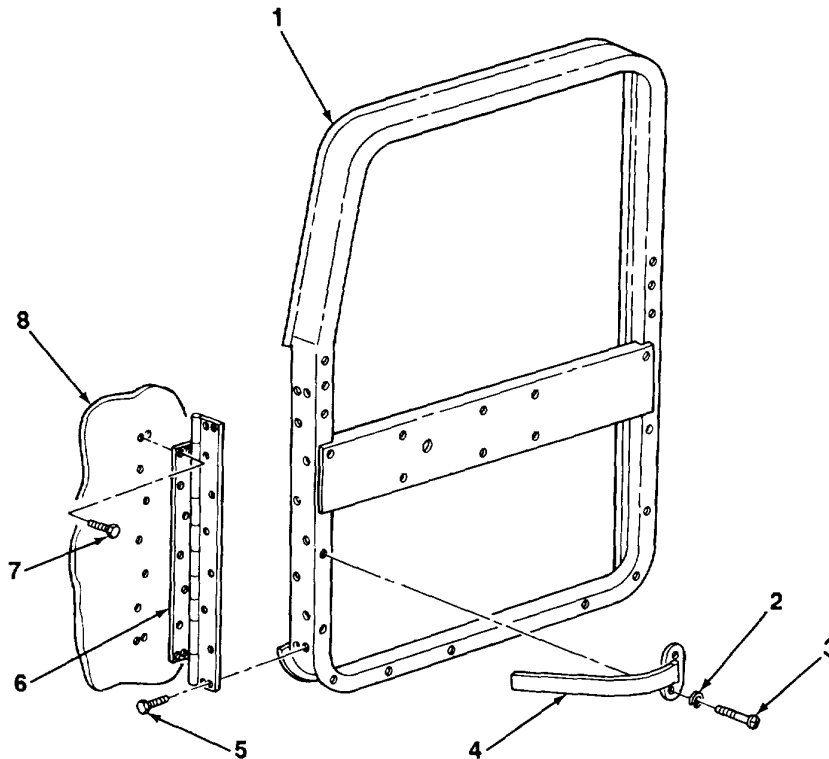

TA704151

15-16. CAB DOOR AND HINGE REPLACEMENT (Con't).

4. If cab door (1) is to be replaced with another, perform the following steps to remove items from the unserviceable door and install them on the serviceable door:
 - (a) Rearview mirror assembly (see TM 5-3805-254-20).
 - (b) Door check (see paragraph 15-9).
 - (c) Dovetail (see paragraph 15-10).
 - (d) Cab door glass and window regulator (see paragraph 15-15).
 - (e) Right door view glass (see paragraph 15-17).
 - (f) Vent window (see paragraph 15-18).
5. Remove all other items from unserviceable cab door (1) and install on serviceable door.

b. INSTALLATION

1. If removed, install hinge (6) on cab (8) with nine screws (7).
2. Install cab door (1) on hinge (6) with ten screws (5).
3. Install door check (4) on cab door (1) with two new lockwashers (2) and screws (3).

FOLLOW-ON TASKS:

- Lubricate door hinge pins (see LO 5-3805-254-12).

15-17. RIGHT DOOR VIEW GLASS REPLACEMENT (Con't).**b. INSTALLATION**

1. Install new weatherseal (4) around edge of view glass (3).
2. Press twine (5) into groove of weatherseal (4) with excess twine meeting at bottom of weatherseal. Use care to keep twine straight and free of kinks.
3. Apply detergent and water solution to groove of weatherseal (4).
4. Position view glass (3) on outside of view glass opening (2) with excess twine (5) on inside of cab door (1).
5. Have assistant press view glass (3) against view glass opening (2) from outside of cab door (1).

NOTE

Hold both sides of twine to prevent twine from pulling free of weatherseal before lip of weatherseal is fully over view glass opening.

6. Pull one end of twine (5) half-way around view glass (3) to raise lip of weatherseal (4) over view glass opening (2).

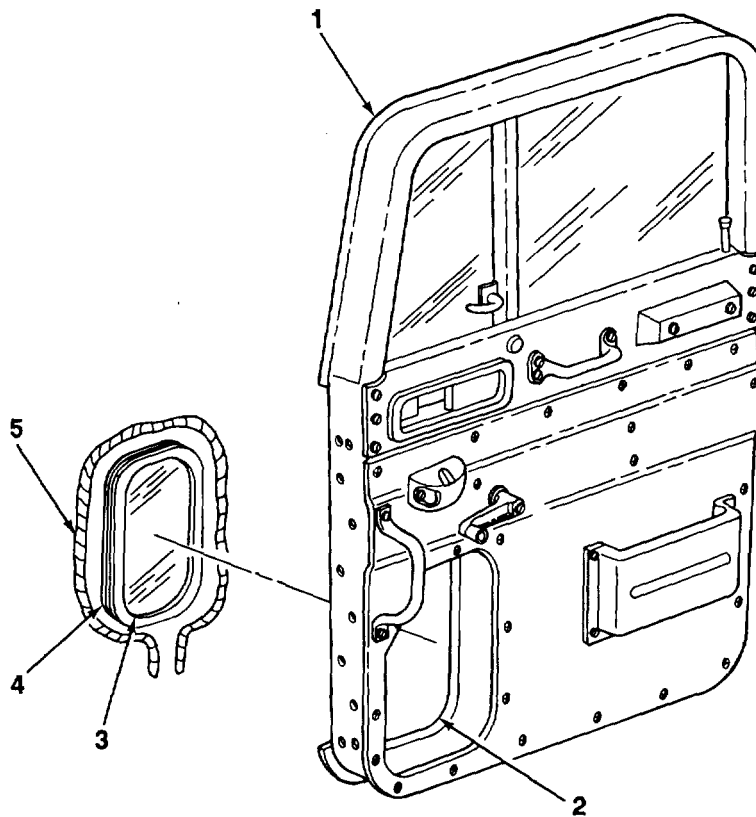

15-17. RIGHT DOOR VIEW GLASS REPLACEMENT (Con't).

7. Pull other end of twine (5) half-way around view glass opening (2) to fully Install view glass (3) and weatherseal (4) in view glass opening.
8. Press around outside of weatherseal (4) to ensure that weatherseal is fully seated in view glass opening (2).
9. Wipe view glass (3), weatherseal (4), and view glass opening (2) free of detergent and water solution.
10. Apply sealant to any areas of weatherseal (4) that appear not fully seated. Wipe off excess sealant.

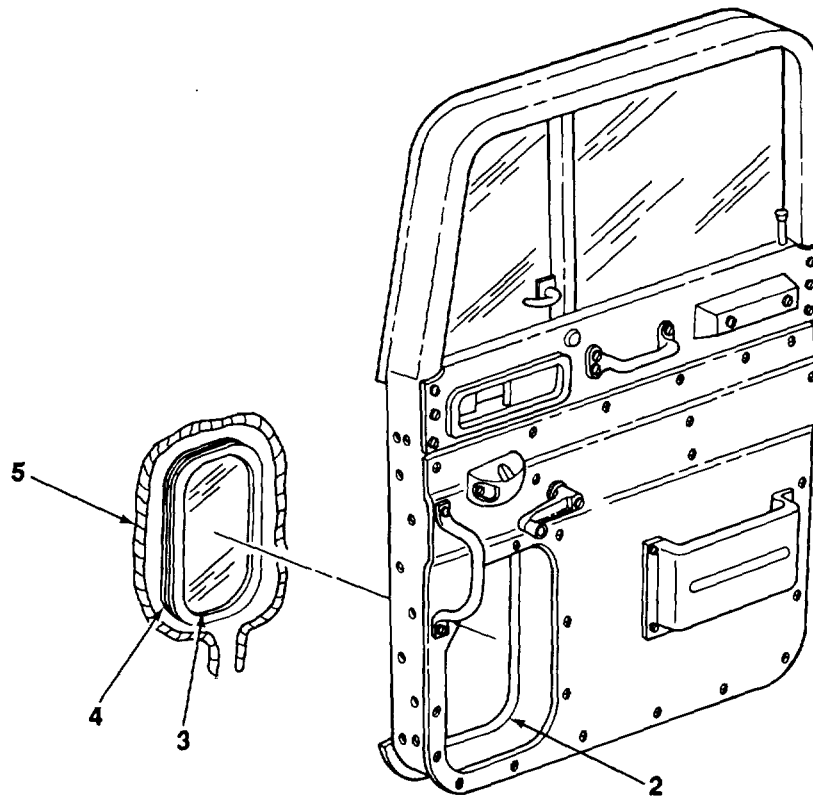

15-18. VENT WINDOW REPLACEMENT (Con't.)

2. Slide top of vent window (3) toward rear of cab door and remove vent window from cab door.
3. Remove weatherseal (2) from cab door. Discard weatherseal.

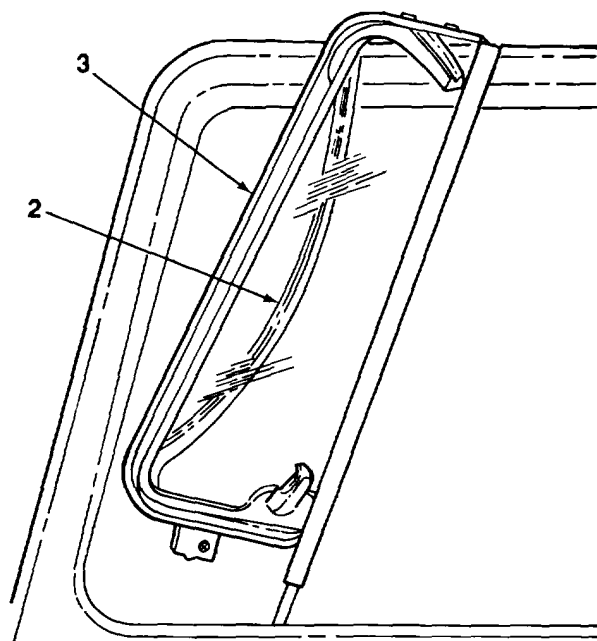
**b. INSTALLATION**

1. Coat weatherseal (2) channel with detergent and water solution and install weatherseal in cab door.
2. Install vent window (3) in cab door by sliding bottom of vent window toward front of cab door.
3. Pull weatherseal (2) out slightly and install four retaining screws (1).
4. Wipe excess detergent and water solution from cab door and vent window (3).

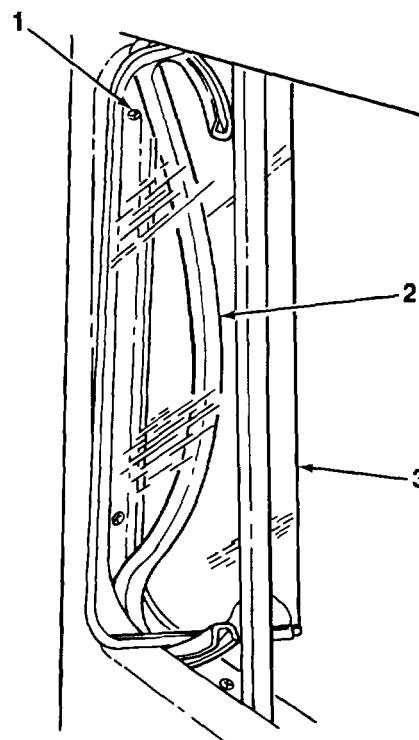

15-19. SUNVISOR REPLACEMENT (Con't).

3. Remove two screws (10) and bracket (9) from bracket (7).
4. Remove two screws (8) and bracket (7) from head retainer (2).

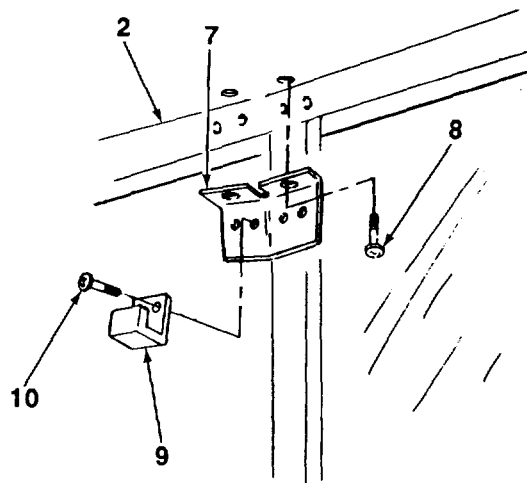

b. INSTALLATION

1. Install bracket (7) to head retainer (2) with two screws (8).
2. Install bracket (9) to bracket (7) with two screws (10).
3. Install sunvisor (3) on visor mounting (1) with screw (5) and nut (6).
4. Install sunvisor (3) and visor mounting (1) on head retainer (2) with three screws (4).

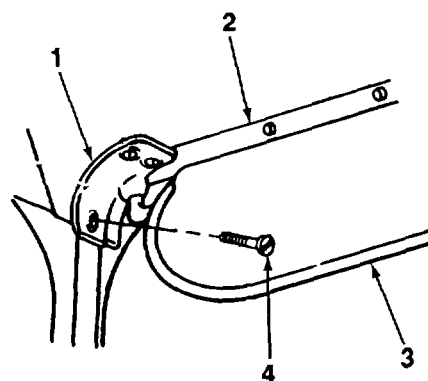
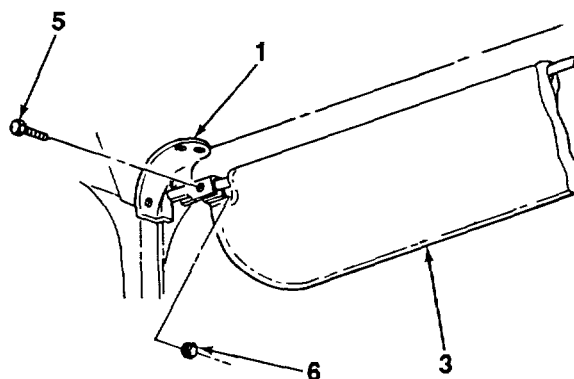

15-20. RADIO OPENING COVER REPLACEMENT.

This Task Covers: Replacement

Initial Setup:

Materials/Parts:

- Six lockwashers

Tools/Test Equipment:

- General mechanic's tool kit
-

REPLACEMENT

1. Remove six screws (2), lockwashers (3), and radio opening cover (4) from panel (1). Discard lockwashers.
2. Install radio opening cover (4) on panel (1) with six new lockwashers (3) and screws (2).

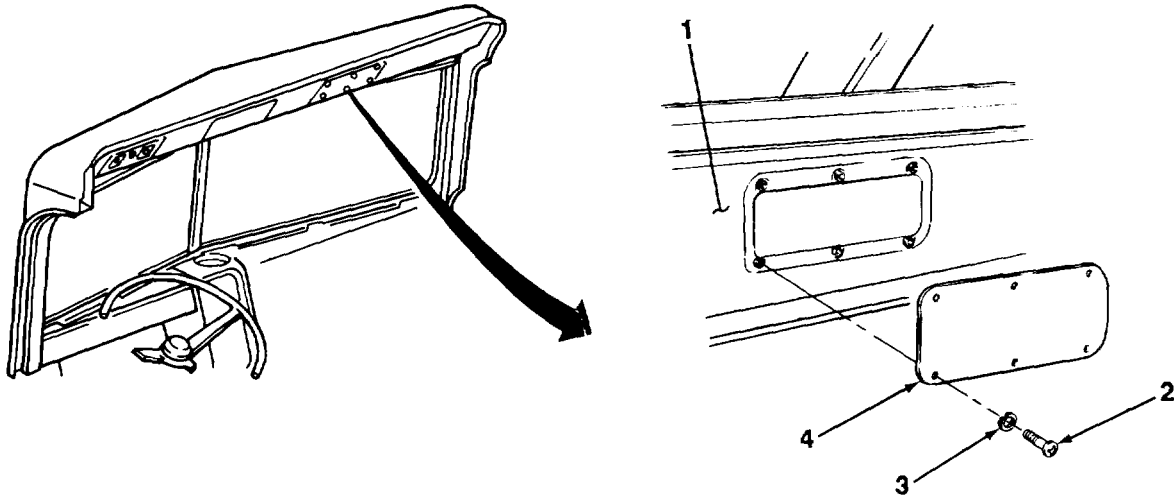

15-21. INSTRUMENT PANEL PAD REPLACEMENT.

This Task Covers:

- a. Removal
- b. Installation

Initial Setup:

Equipment Conditions:

- Battery cables disconnected (see TM 5-3805-254-20).
- Right instrument panel opened (see TM 5-3805-254-20).

Tools/Test Equipment:

- General mechanic's tool kit

a. REMOVAL

1. Turn three thumbscrews (1) counterclockwise until fully loosened.
2. Lower instrument panel pad (2) and move to left to disconnect from two hinges (3). Remove Instrument panel pad from cab.

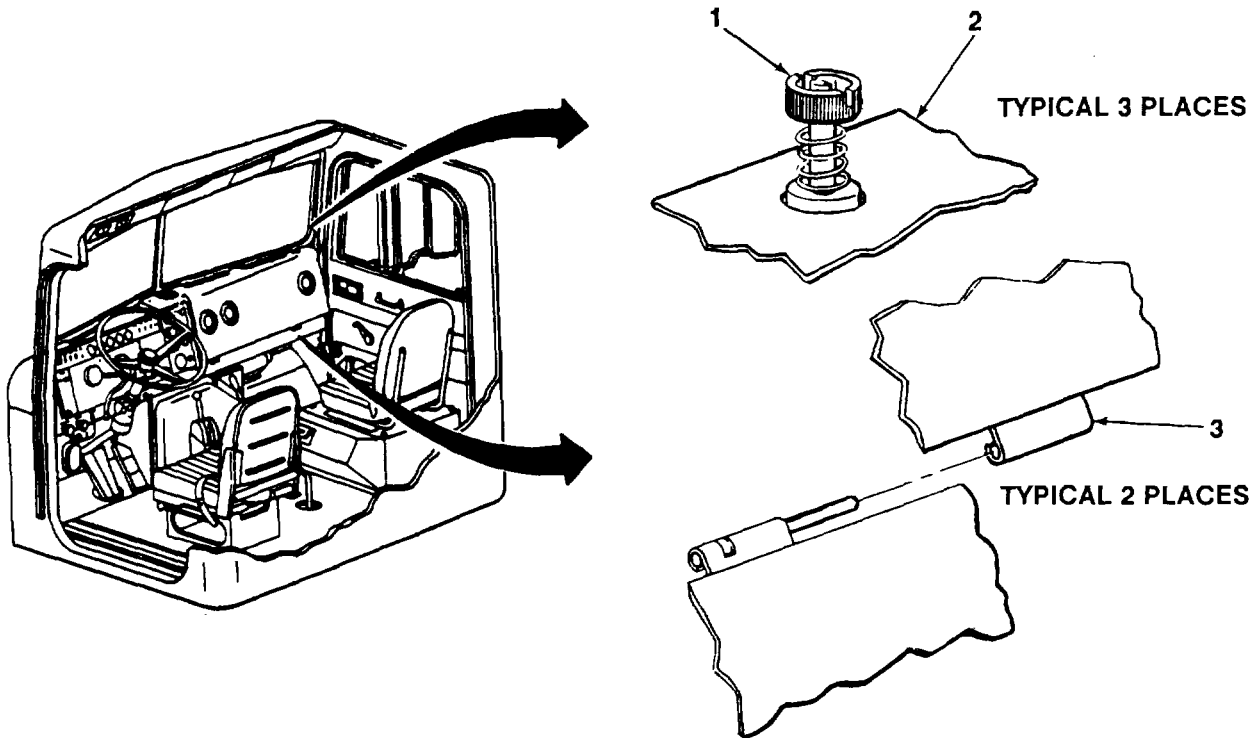

15-21. INSTRUMENT PANEL PAD REPLACEMENT (Con't).

b. INSTALLATION

1. Aline two hinges (3) and move instrument panel pad (2) to right to secure.
2. Raise instrument panel pad (2) to position in cab and tighten three thumbscrews (1).

FOLLOW-ON TASKS:

- Close right instrument panel (see TM 5-3805-254-20).
- Connect battery cables (see TM 5-3805-254-20).

15-22. INSTRUMENT PANELS REPLACEMENT.

This Task Covers:

- | | | | |
|----|--------------------------------|----|-------------------------------------|
| a. | Right Instrument Panel Removal | c. | Left Instrument Panel Installation |
| b. | Left Instrument Panel Removal | d. | Right Instrument Panel Installation |
-

Initial Setup:

Tools/Test Equipment:

- General mechanic's tool kit

References:

- TM 5-3805-254-20
-

a. RIGHT INSTRUMENT PANEL REMOVAL

1. Remove right instrument panel optical ribbon (see TM 5-3805-254-20).
2. Remove fuel pressure gage (see TM 5-3805-254-20).
3. Remove transmission oil pressure gage (see TM 5-3805-254-20).
4. Remove transmission temperature gage (see TM 5-3805-254-20).
5. Remove air cleaner vacuum gage (see TM 5-3805-254-20).

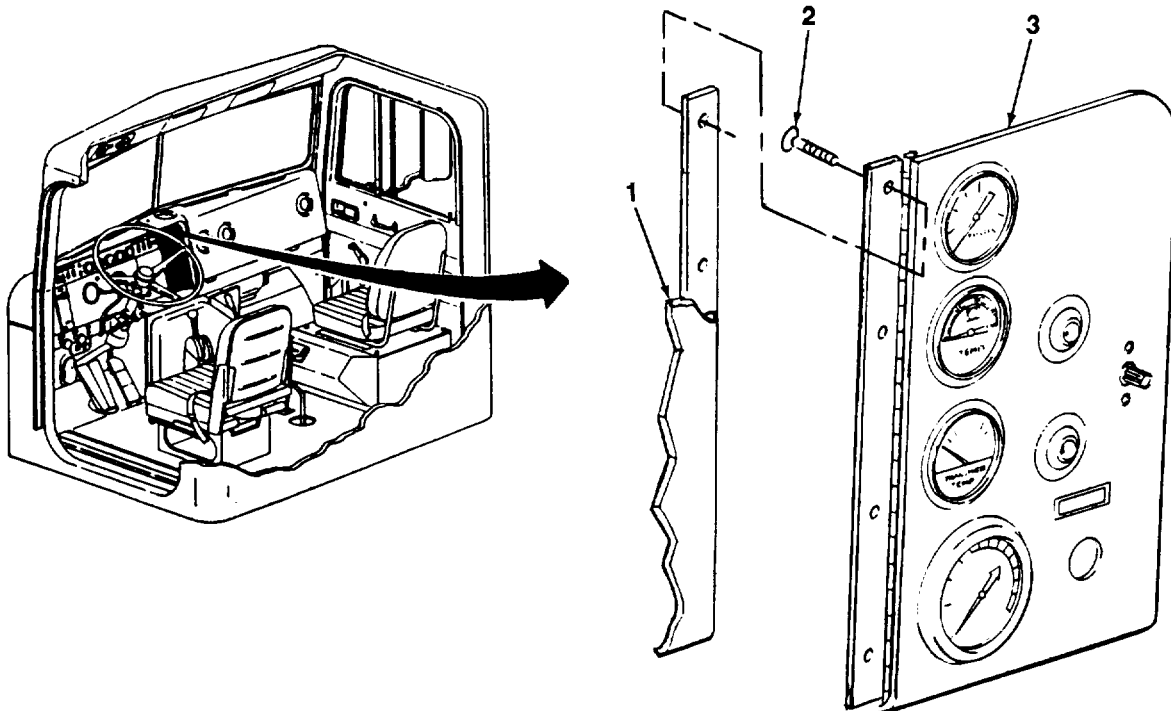

15-22. INSTRUMENT PANELS REPLACEMENT (Con't).

6. Remove transmission pressure gage indicator lamp (see TM 5-3805-254-20).
7. Remove transmission temperature indicator lamp (see TM 5-3805-254-20).
8. Remove four screws (2) and right instrument panel (3) from left instrument panel (1).

b. LEFT INSTRUMENT PANEL REMOVAL

1. Remove upper center panel (see TM 5-3805-254-20).
2. Remove lower center panel (see TM 5-3805-254-20).
3. Remove left instrument panel optical ribbon (see TM 5-3805-254-20).
4. Remove power divider control (see TM 5-3805-254-20).
5. Remove power divider indicator lamp (see TM 5-3805-254-20).
6. Remove right instrument panel (see subparagraph a).
7. Remove instrument panel pad (see paragraph 15-21).
8. Remove parking brake control valve (see TM 5-3805-254-20).
9. Remove key switch (see TM 5-3805-254-20).
10. Remove engine start switch (TM 5-3805-254-20).

15-22. INSTRUMENT PANELS REPLACEMENT (Con't).

11. Remove six screws (5) and left instrument panel (1) from cab (4).

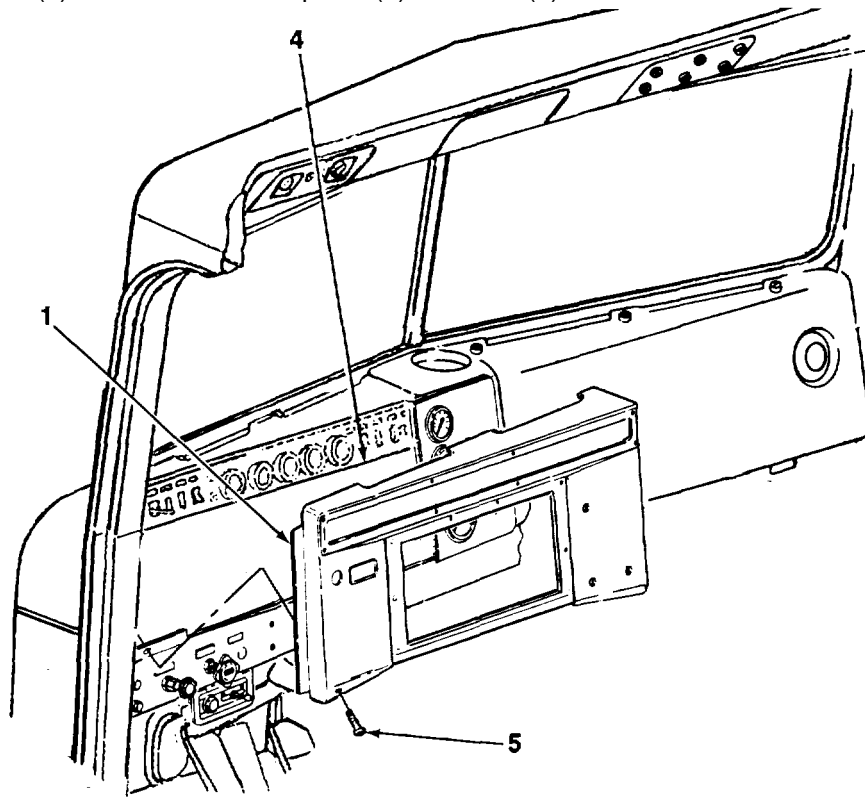
**C. LEFT INSTRUMENT PANEL INSTALLATION**

1. Install left instrument panel (1) to cab (4) with six screws (5).
2. Install engine start switch (see TM 5-3805-254-20).
3. Install key switch (see TM 5-3805-254-20).
4. Install parking brake control valve (see TM 5-3805-254-20).
5. Install instrument panel pad (see paragraph 15-21).
6. Install right instrument panel (see subparagraph a).
7. Install power divider indicator lamp (see TM 5-3805-254-20).
8. Install power divider control (see TM 5-3805-254-20).

TA704162

15-22. INSTRUMENT PANELS REPLACEMENT (Con't).

9. Install left instrument panel optical ribbon (see TM 5-3805-254-20).
10. Install lower center panel (see TM 5-3805-254-20).
11. Install upper center panel (see TM 5-3805-254-20).

f. RIGHT INSTRUMENT PANEL INSTALLATION

1. Install right instrument panel (3) to left instrument panel (1) with four screws (2).
2. Install transmission temperature indicator lamp (see TM 5-3805-254-20).
3. Install transmission pressure indicator lamp (see TM 5-3805-254-20).
4. Install air cleaner vacuum gage (see TM 5-3805-254-20).
5. Install transmission temperature gage (see TM 5-3805-254-20).
6. Install transmission oil pressure gage (see TM 5-3805-254-20).
7. Install fuel pressure gage (see TM 5-3805-254-20).

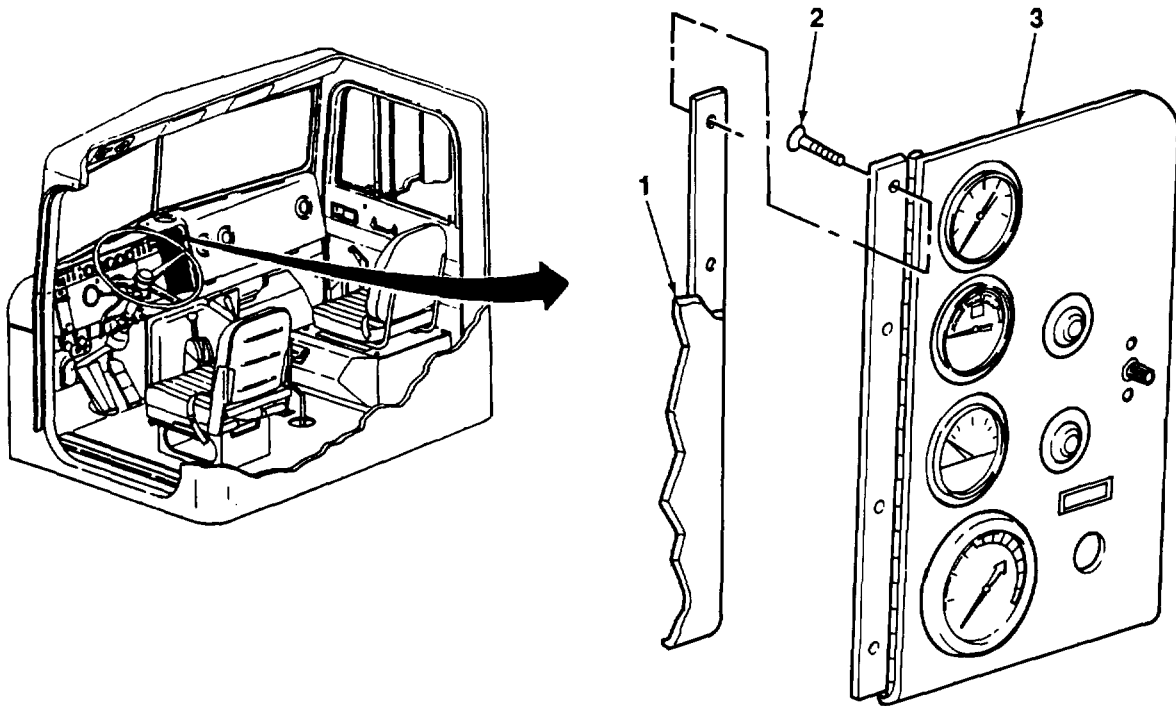

15-23. HEADLINING REPLACEMENT (Con't).

4. Remove headlining (1) and insulation (8) from cab ceiling (7).

b. INSTALLATION

1. Position insulation (8) and headlining (1) on cab ceiling (7).

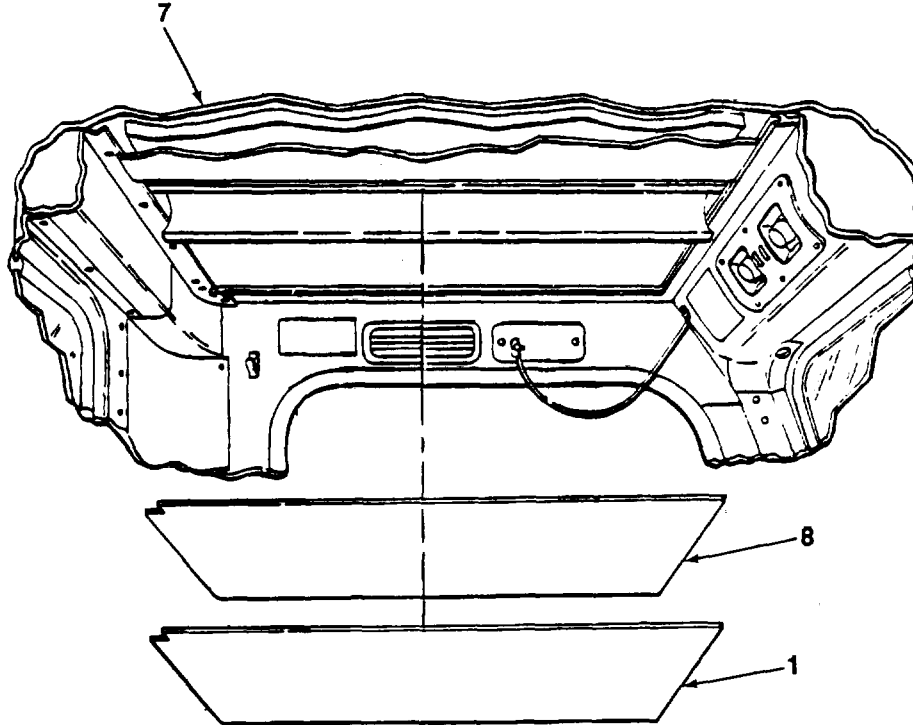

2. Install four retainers (6) and spacer (2) on headlining (1) with 14 screws (3).
3. If removed, install eight caps (4) on four moldings (5).
4. Install four moldings (5) on retainers (6).

TA704165

15-24. FENDER MAINTENANCE.

This Task Covers:

- | | | | |
|----|-------------------------|----|--------------|
| a. | Removal | d. | Assembly |
| b. | Disassembly | e. | Installation |
| c. | Cleaning and Inspection | | |

Initial Setup:

Equipment Conditions:

- Headlight removed (see TM 5-3805-254-20).
- Front fender reflectors removed (see TM 5-3805-254-20).
- Front turn signal removed (see TM 5-3805-254-20).
- Splashguard removed (see TM 5-3805-254-20).

Materials/Parts:

- Detergent (Item 6, Appendix B)
- Nineteen lockwashers

References:

- TM 9-237

Tools/Test Equipment:

- General mechanic's tool kit
- Field automotive shop set

Personnel Required: Two**a. REMOVAL**

1. Remove three nuts (7) and screws (5) from angle (6) and front support (8).
2. Remove three nuts (3), screws (4), and fender (1) from rear Support (2) and truck.

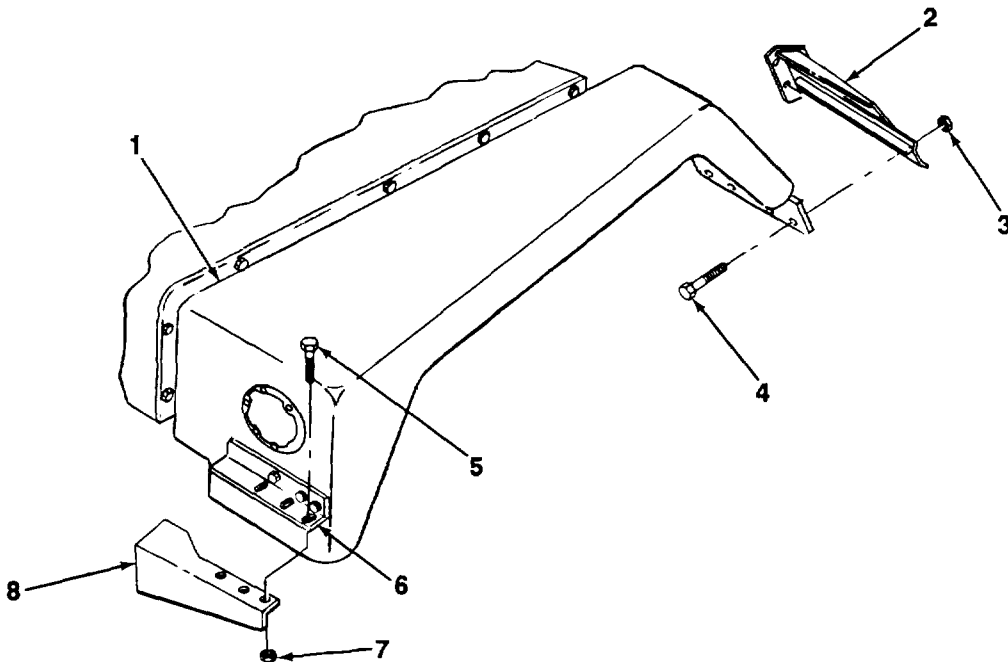

15-24. FENDER MAINTENANCE (Con't).

b. DISASSEMBLY

- 1. Remove four nuts (19), washers (20), screws (22), lockwashers (21), and angle (6) from fender (1). Discard lockwashers.
- 2. Remove five nuts (18), lockwashers (17), screws (14), washers (15), and support (16) from fender (1) and mount (26). Discard lockwashers.
- 3. Remove four nuts (9), screws (23), lockwashers (24), and angle (25) from fender (1) and mount (26). Discard lockwashers.
- 4. Remove six nuts (10), washers (11), screws (13), lockwashers (12), and mount (26) from fender (1). Discard lockwashers.

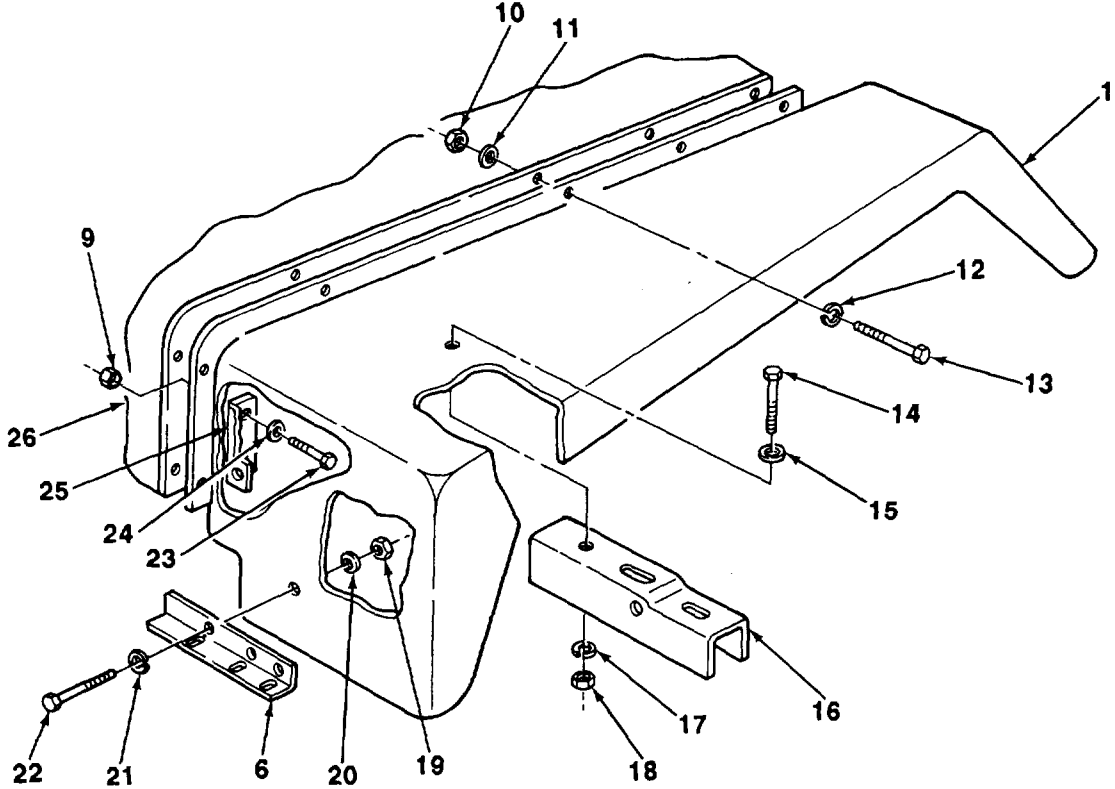

15-24. FENDER MAINTENANCE (Con't).**c. CLEANING AND INSPECTION**

1. Clean parts with detergent and water solution and inspect for damage. Replace damaged parts.
2. Inspect fender for cracks and damage. Weld cracks. Refer to TM 9-237 for welding instructions. Replace fender if damaged beyond repair.
3. Inspect rear support (2) for damage. If damaged, remove three screws (30), washers (29), and rear support from truck.
4. Inspect front support (8) for damage. If damaged, remove three screws (27), washers (28), and front support from truck.

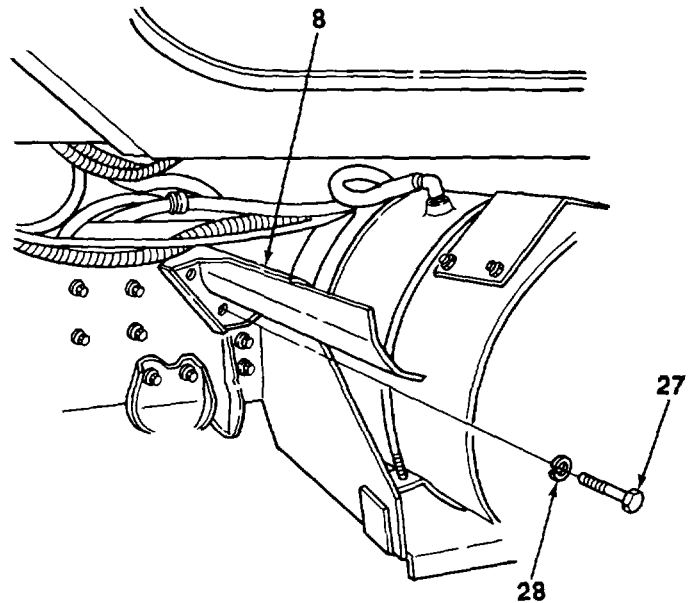
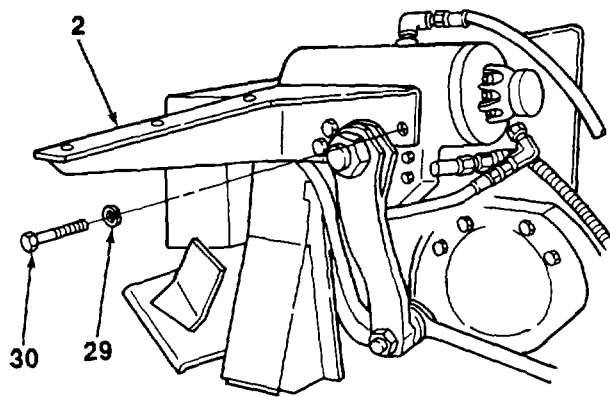
**d. ASSEMBLY**

1. If removed, install front support (8) on truck with three washers (28) and screws (27).
2. If removed, install rear support (2) on truck with three washers (29) and screws (30).

TA704168

15-24. FENDER MAINTENANCE (Con't).

- 3. Install mount (26) on fender (1) with six new lockwashers (12), screws (13), washers (11), and nuts (10).
- 4. Install angle (25) on fender (1) and mount (26) with four screws (23), new lockwashers (24), and nuts (9).
- 5. Install support (16) on fender (1) and mount (26) with five washers (15), screws (14), new lockwashers (17), and nuts (18).
- 6. Install angle (6) on fender (1) with four new lockwashers (21), screws (22), washers (20), and nuts (19).

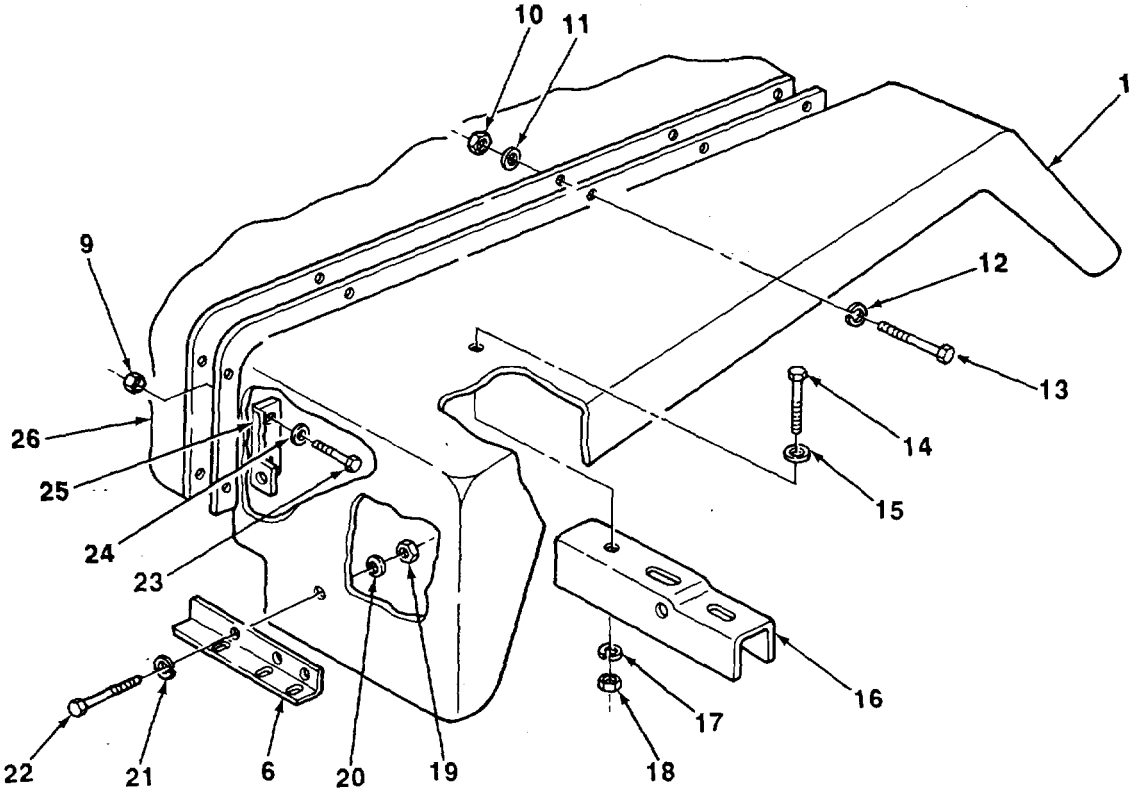

15-24. FENDER MAINTENANCE (Con't).**e. INSTALLATION**

1. Position fender (1) on rear support (2) and install three screws (4) and nuts (3) on rear support and angle (6).
2. Install three screws (5) and nuts (7) on angle (6) and front support (8).

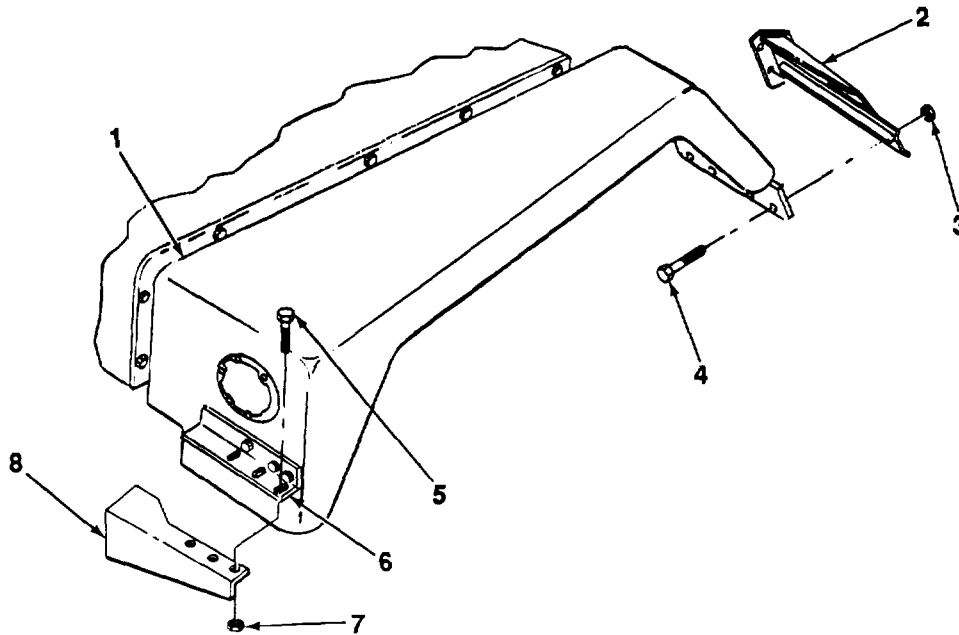
**FOLLOW-ON TASKS:**

- Install splashguard (see TM 5-3805-254-20).
- Install front fender reflectors (see TM 5-3805-254-20).
- Install front turn signal (see TM 5-3805-254-20).
- Install headlight (see TM 5-3805-254-20).

TA704170

15-25. WINDSHIELD GLASS REPLACEMENT.

This Task Covers:

- a. Removal
- b. Installation

Initial Setup:

Equipment Conditions:

- Wiper blades and arms removed (see TM 5-3805-254-20).
- Sunvisors removed (see paragraph 15-19).
- Rubber cement (Item 18, Appendix B)

Materials/Parts:

- Detergent (Item 6, Appendix B)
- Rags (Item 17, Appendix B)
- Rubber cement (Item 18, Appendix B)
- Twine (Item 32, Appendix B)
- Two weatherseals

Tools/Test Equipment:

* General mechanic's tool kit

Personnel Required: Two

a. REMOVAL

1. Remove three nuts (6), Inner windshield bar (5), and outer windshield bar (3) from dividing weatherseal (2),
2. From Inside of cab, cut off lip of weatherseal (4) around windshield (1) opening of cab.
3. Press outward on two windshields (1) and remove windshield, weatherseal (4), and dividing weatherseal (2) from windshield opening of cab. Discard weatherseals.
4. Clean windshield (1) opening of cab of rubber cement.

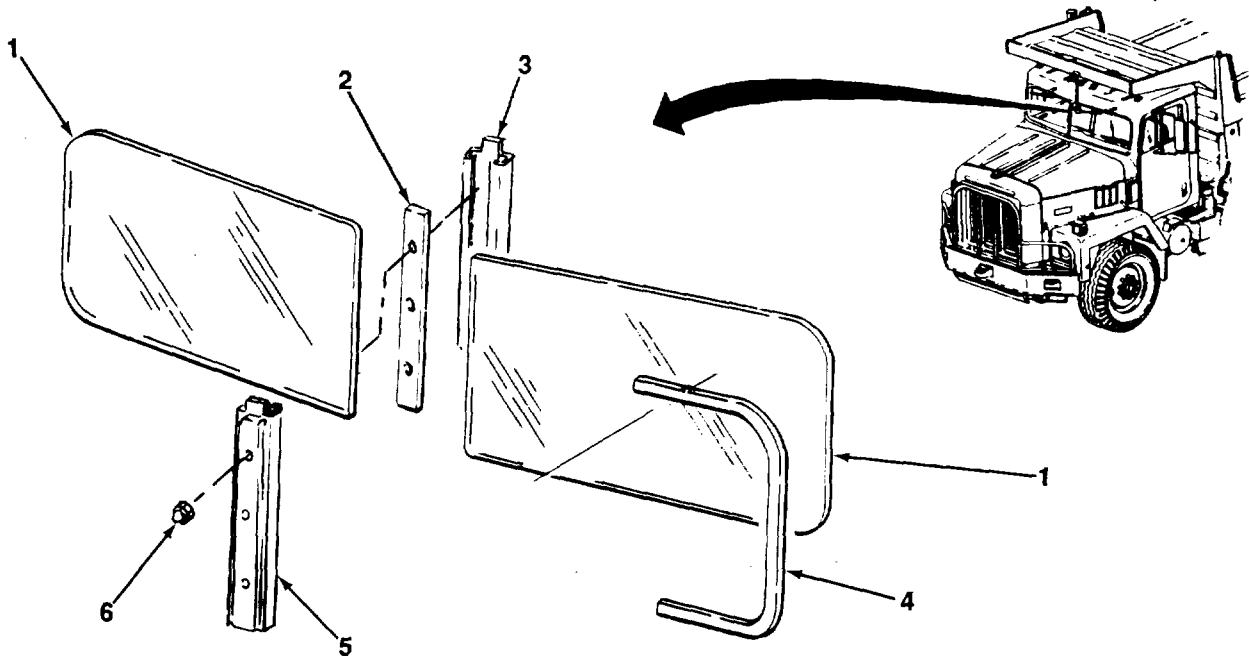

15-25. WINDSHIELD GLASS REPLACEMENT (Con't).**b. INSTALLATION**

1. On flat surface with forward surface of two windshields (1) facing downward, install new dividing weatherseal (2) between edges of windshields.
2. Install new weatherseal (4) around outside edge of windshields (1) with lip of weatherseal facing upward.
3. Press twine into groove of weatherseal (4) with excess twine meeting at bottom of dividing weatherseal (2). Use care to keep twine straight and free of kinks.
4. Apply detergent and water solution to groove of weatherseal (4).
5. Position two windshields (1) to outside windshield opening of cab with excess twine inside cab.

NOTE

Hold both sides of twine to prevent twine from pulling free of weatherseal before lip of weatherseal is fully over windshield opening.

6. While pressing two windshields (1) against windshield opening of cab, pull one end of twine half-way around windshield opening to raise lip of weatherseal (4) over windshield opening of cab.

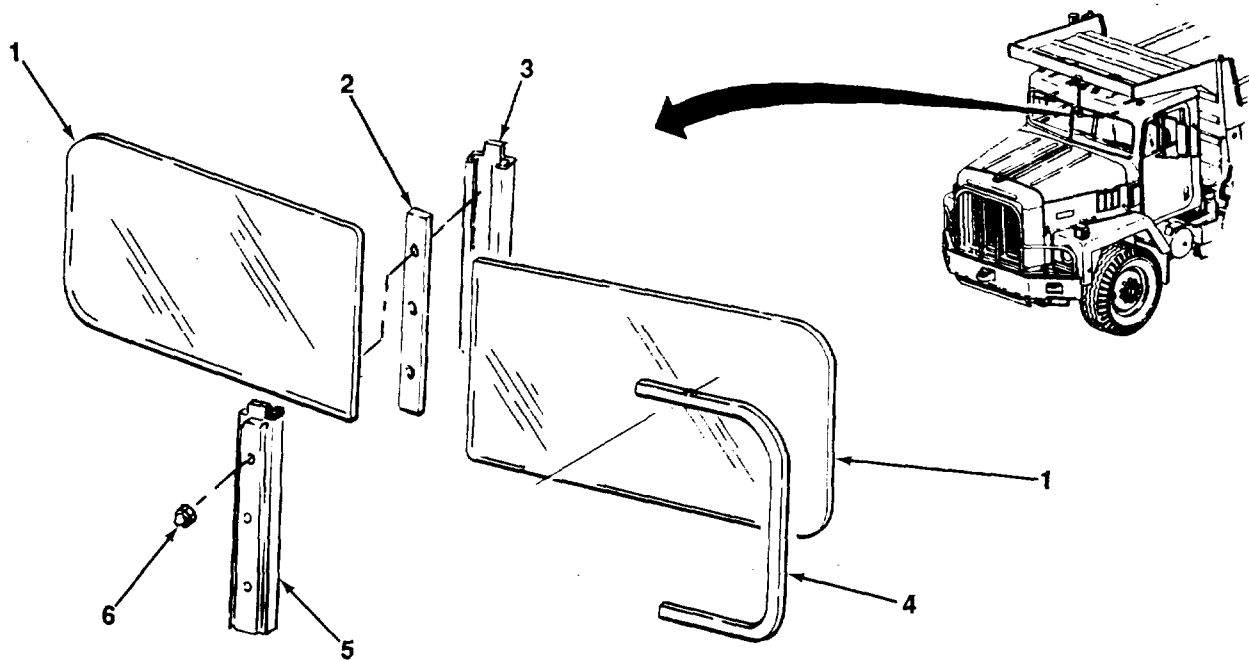

7. While pressing two windshields (1) against windshield opening of cab, pull other end of twine half-way around windshield opening to fully install windshields and weatherseal (4).
8. Press around outside of weatherseal (4) to ensure that weatherseal is fully seated in windshield (1) opening of cab.

15-25. WINDSHIELD GLASS REPLACEMENT (Con't).

9. Wipe two windshields (1), weatherseal (4), and windshield opening free of detergent and water solution.
10. Apply rubber cement to any areas of weatherseal (4) that appear not fully sealed. Wipe off excess rubber cement.
11. Install outer windshield bar (3) and inner windshield bar (5) on dividing weatherseal (2) with three nuts (6).

FOLLOW-ON TASKS:

- Install sunvisors (see paragraph 15-19).
- Install wiper blades and arms (see TM 5-3805-254-20).

15-26. CAB REAR GLASS REPLACEMENT.

This Task Covers:

a. Removal

b. Installation

Initial Setup:

Equipment Conditions:

- Dump body fully raised (see TM 5-3805-254-10).

Materials/Parts:

- Detergent (Item 6, Appendix B)
- Rags (Item 17, Appendix B)
- Rubber cement (Item 18, Appendix B)
- Twine (Item 32, Appendix B)

Tools/Test Equipment:

- General mechanic's tool kit
- One weatherseal

Personnel Required: Two

a. REMOVAL

1. From inside of cab, cut off lip of weatherseal (2) around rear glass (1) opening.
2. Press outward on rear glass (1) and remove rear glass and weatherseal (2) from cab. Discard weatherseal.
3. Clean rear glass (1) opening of rubber cement.

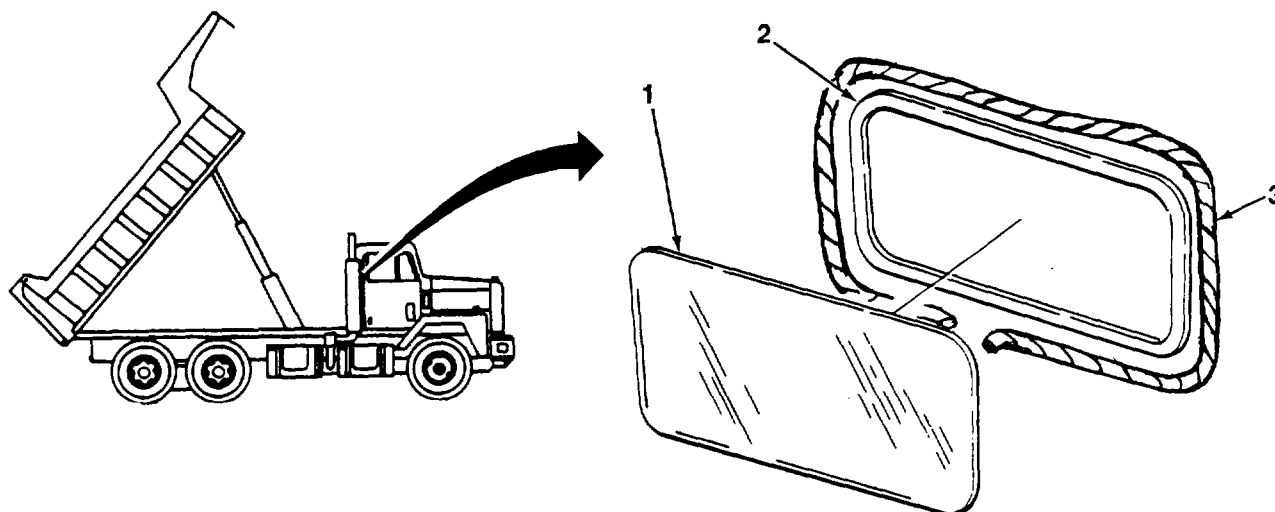

15-26. CAB REAR GLASS REPLACEMENT (Con't).

b. INSTALLATION

1. Install new weatherseal (2) around edge of rear glass (1).
2. Press twine (3) into groove of weatherseal (2) with excess twine meeting at bottom of weatherseal. Use care to keep twine straight and free of kinks.
3. Apply detergent and water solution to groove of weatherseal (2).
4. Position rear glass (1) on outside of rear glass opening with excess twine (3) inside cab.
5. Have assistant press rear glass (1) against rear glass opening from outside of cab.

NOTE

Hold both sides of twine to prevent twine from pulling free of weatherseal before lip of weatherseal is fully over rear glass opening.

6. Pull one end of twine (3) half-way around rear glass (1) to raise lip of weatherseal (2) over rear glass opening.
7. Pull other end of twine (3) half-way around rear glass (1) opening to fully install rear glass and weatherseal (2) in rear glass opening.
8. Press around outside of weatherseal (2) to ensure that weatherseal is fully seated in rear glass (1) opening.
9. Wipe rear glass (1), weatherseal (2), and rear glass opening free of detergent and water solution.
10. Apply rubber cement to any areas of weatherseal (2) that appear not fully seated. Wipe off excess rubber cement.

FOLLOW-ON TASKS:

- Lower dump body (see TM 5-3805-254-10).

15-27. TAILGATE RELEASE LEVER AND LINKAGE REPLACEMENT.

This Task Covers:

- | | | | |
|----|-------------------------|----|--------------|
| a. | Removal | c. | Installation |
| b. | Cleaning and Inspection | | |
-

Initial Setup:

Materials/Parts:

- Dry cleaning solvent (Item 23, Appendix B)
- Four cotter pins

Tools/Test Equipment:

- General mechanic's tool kit

Personnel Required: Two

General Safety Instructions:

- Dry cleaning solvent is flammable and must not be used near open flame. Use only in a well-ventilated area.
-

a. REMOVAL

1. Remove cotter pin (5), clevis pin (3), and clevis (4) from hook (6). Discard cotter pin.
2. Remove clevis (4) and nut (2) from pull rod (1).
3. Count number of threads showing at end of pull rod (1), then remove nut (2) from pull rod.

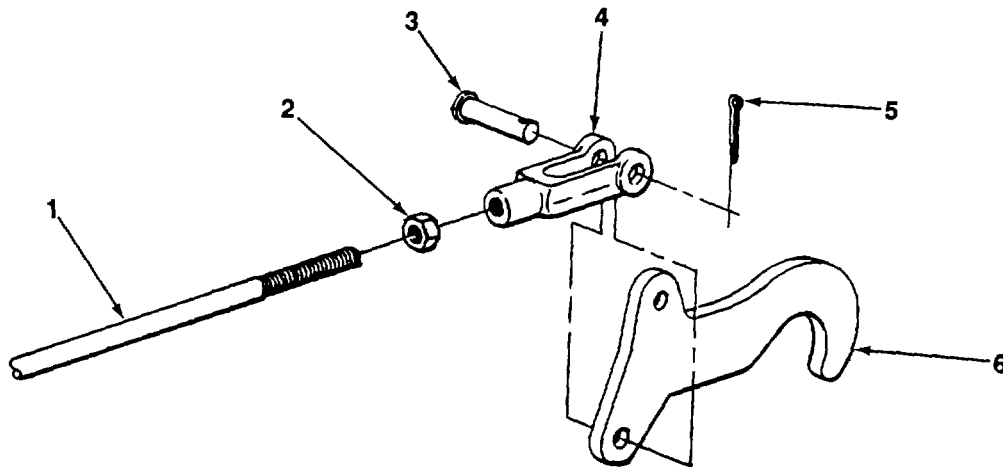

15-27. TAILGATE RELEASE LEVER AND LINKAGE REPLACEMENT (Con't).

- 4. Remove nut (13), two flatwashers (8), and screw (7) from two connecting rods (9) and lever (14).
- 5. Remove cotter pin (12), clevis pin (10), and pull rod (1) from two connecting rods (9). Discard cotter pin.
- 6. With assistance, remove pull rod (1) from pull rod holes (11) in dump body.

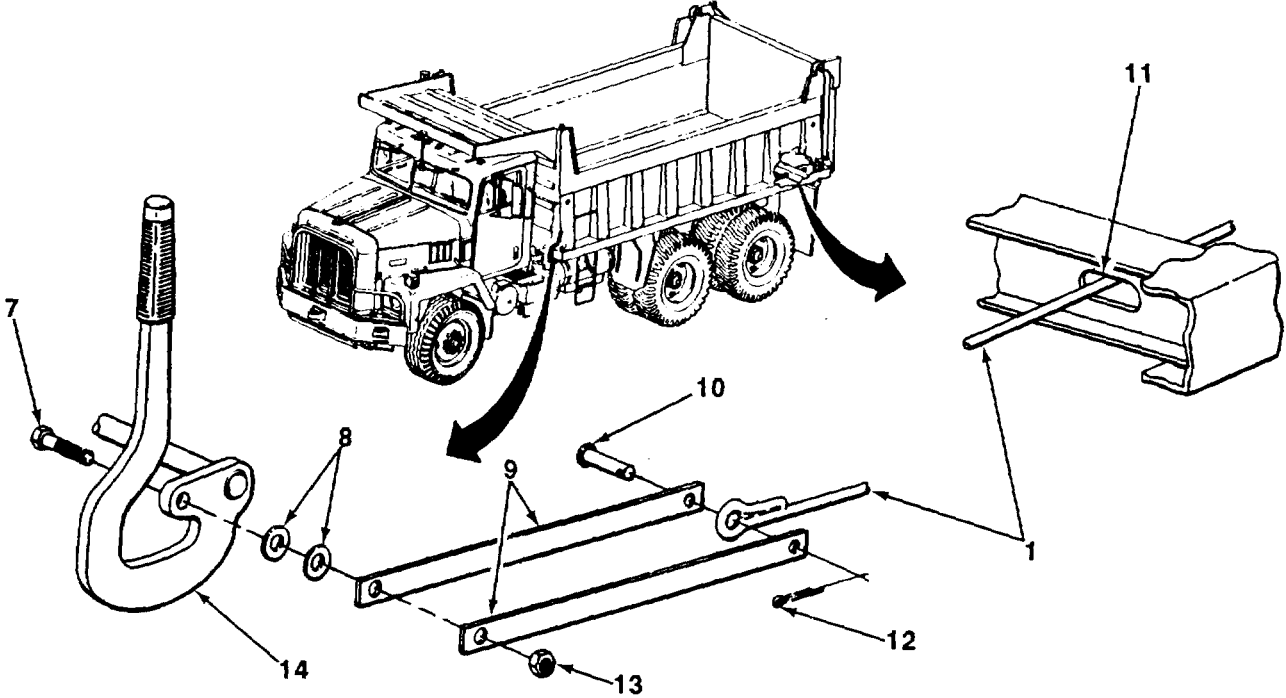

- 7. Remove cotter pin (15), clevis pin (17), and clevis (16) from hook (20). Discard cotter pin.
- 8. Remove clevis (16) from pull rod (19).
- 9. Count number of threads showing at end of pull rod (19), then remove nut (18) from pull rod.

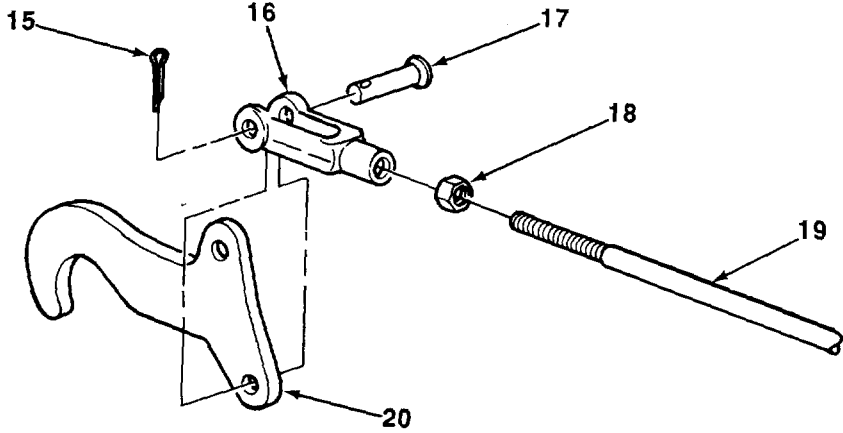

15-27. TAILGATE RELEASE LEVER AND LINKAGE REPLACEMENT (Con't).

- 10. Remove nut (21), two flatwashers (28), screw (27), and two connecting rods (22) from crank (26).
- 11. Remove cotter pin (23), clevis pin (25), and pull rod (19) from two connecting rods (22). Discard cotterpin.
- 12. With assistance, remove pull rod (19) from pull rod holes (24) in dump body.

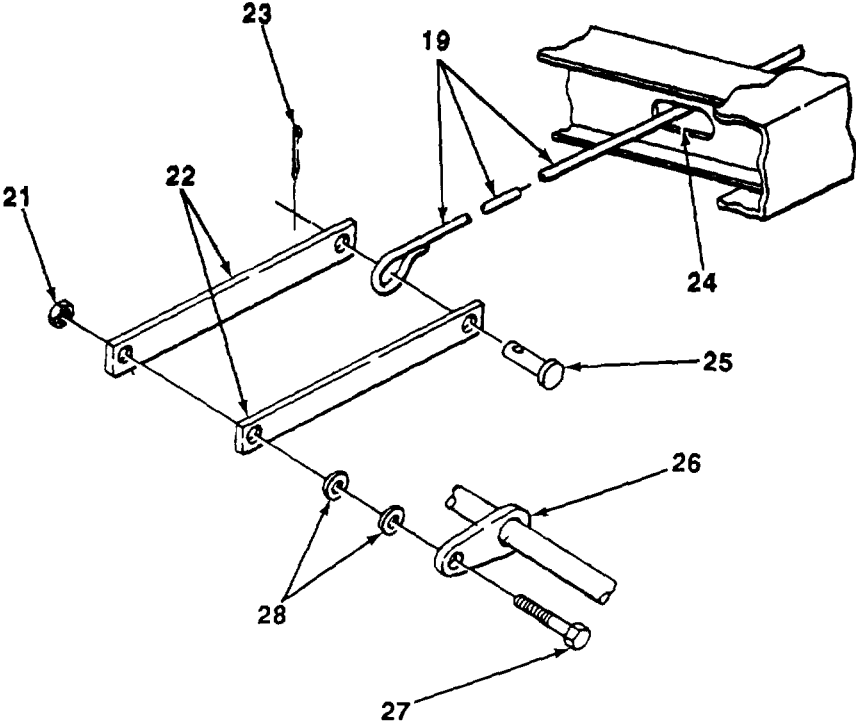

TA704176

15-27. TAILGATE RELEASE LEVER AND LINKAGE REPLACEMENT (Con't).

13. Remove lever (14) from roller rod (29) and dump body.
14. With assistance, remove roller rod (29) from crank (26) and dump body.

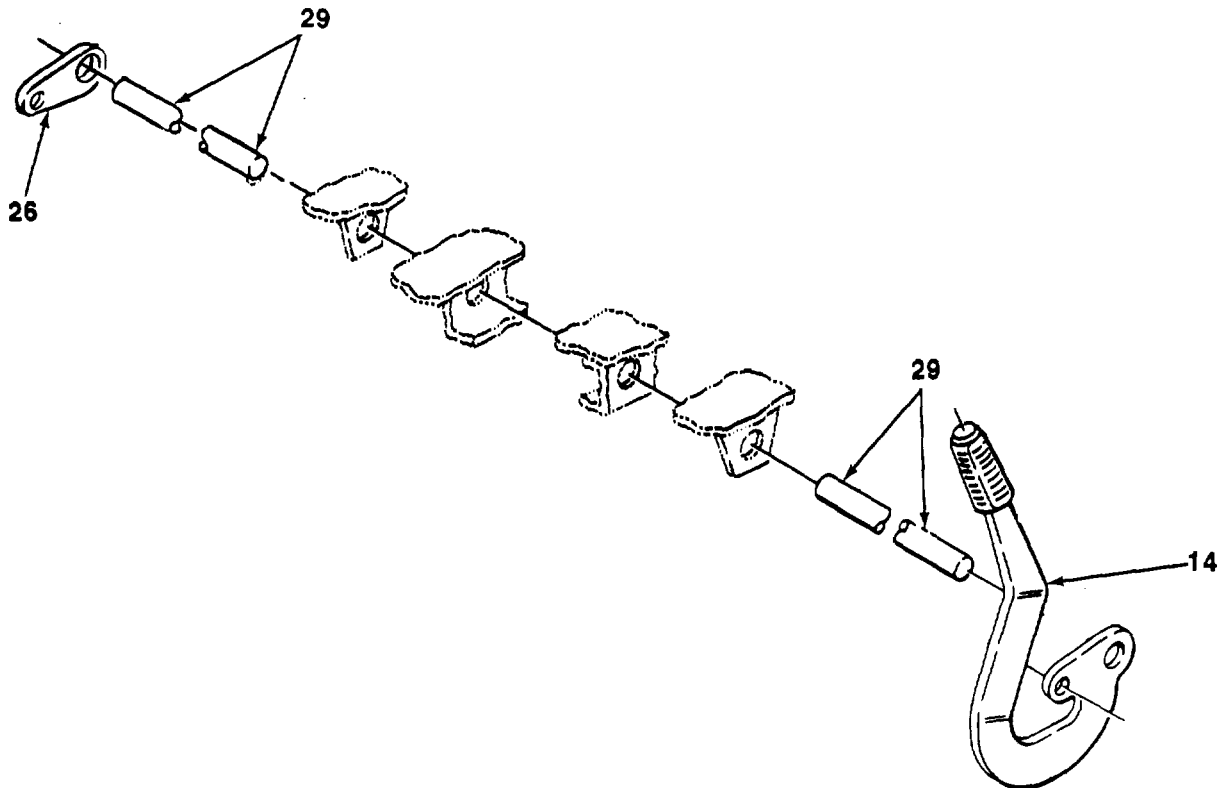
**b. CLEANING AND INSPECTION****WARNING**

Dry cleaning solvent, P-D-680, is toxic and flammable. Always wear protective goggles and gloves, and use only in a well-ventilated area. Avoid contact with skin, eyes, and clothes, and DO NOT breathe vapors. DO NOT use near open flame or excessive heat. The solvent's flash point is 1000F-1380F (380C-590C). If you become dizzy while using cleaning solvent, immediately get fresh air and medical help. If solvent contacts eyes, immediately wash your eyes and get medical aid.

1. Clean parts with dry cleaning solvent.
2. Inspect parts for wear, bends, breaks, or corrosion. Replace parts if damaged.

c. INSTALLATION

1. Install roller rod (29) through crossmembers and position in crank (26).
2. Position lever (14) on roller rod (29) and dump body.

15-27. TAILGATE RELEASE LEVER AND LINKAGE REPLACEMENT (Con't).

3. With the aid of an assistant, position pull rod (19) in pull rod holes (24) in dump body.
4. Install pull rod (19) on two connecting rods (22) with clevis pin (25) and new cotter pin (23).
5. Install two connecting rods (22) on crank (26) with screw (27), two flatwashers (28), and nut (21).

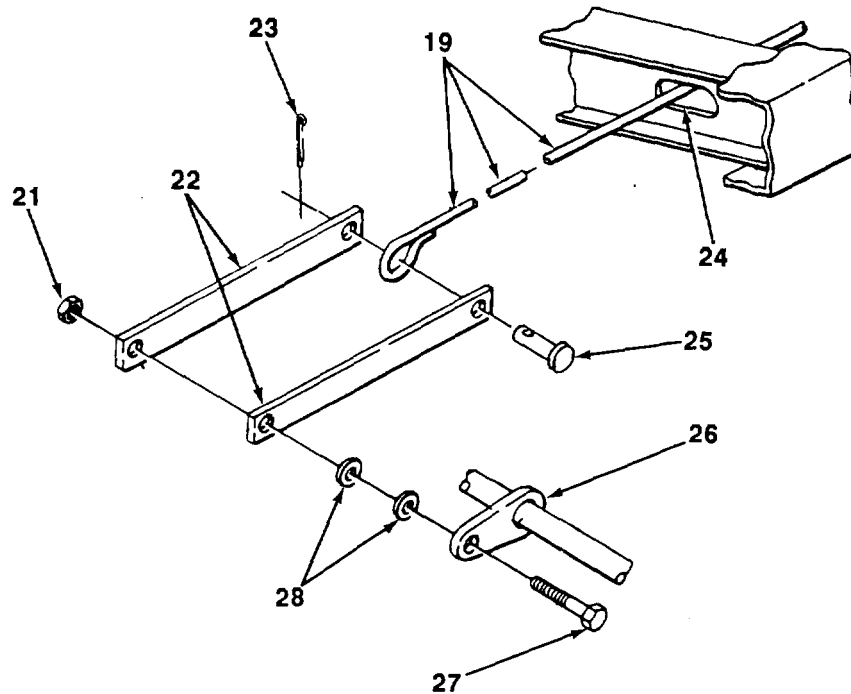

6. Install nut (18) on pull rod (19) until number of threads counted in removal are showing.

NOTE

Tailgate must be completely closed and hook must be tight against tailgate pins.

7. Install clevis (16) on pull rod (19). Aline hole in clevis with hole in hook (20). Tighten nut (18).
8. Install clevis (16) on hook (20) with clevis pin (17) and new cotter pin (15).

TA704178

15-27. TAILGATE RELEASE LEVER AND LINKAGE REPLACEMENT (Con't).

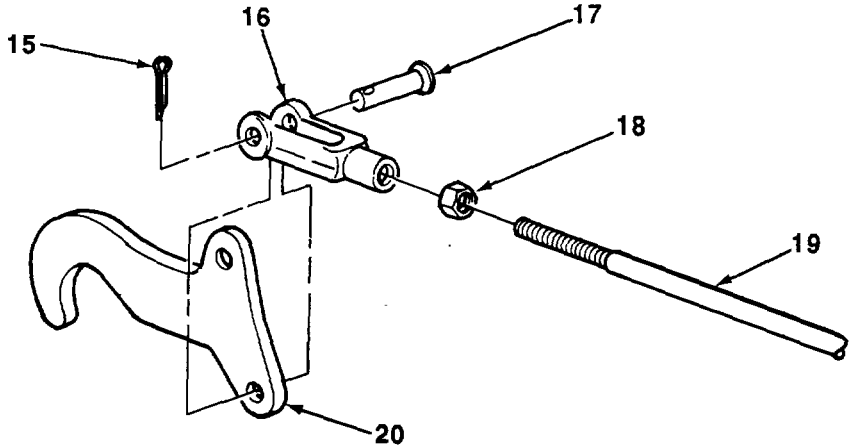

- 9. Position pull rod (1) In pull rod holes (11).
- 10. Install pull rod (1) on two connecting rods (9) with clevis pin (10) and new cotter pin (12).
- 11. With the aid of an assistant, install two connecting rods (9) on lever (14) with screw (7), two flatwashers (8), and nut (13).

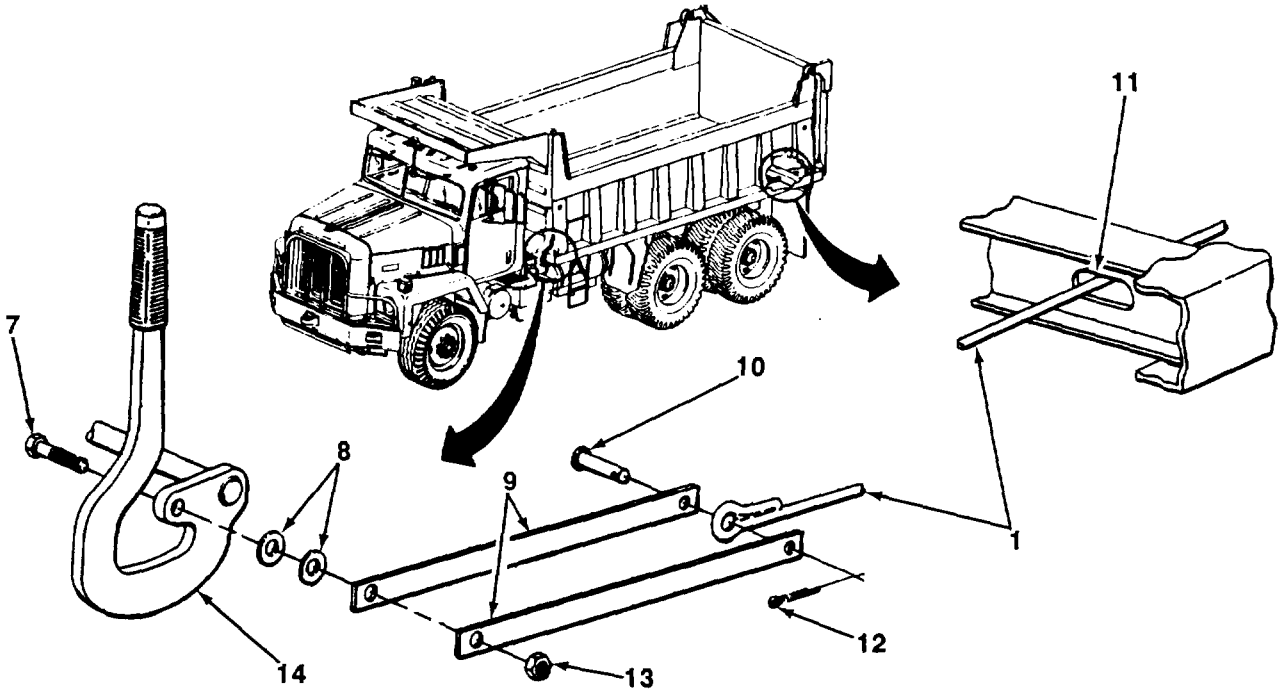

15-27. TAILGATE RELEASE LEVER AND LINKAGE REPLACEMENT (Con't).

12. Install nut (2) on pull rod (1) until number of threads counted in removal are showing.

NOTE

Tailgate must be completely closed and hook must be tight against tailgate pins.

13. Install clevis (4) on pull rod (1). Aline hole in clevis with hole in hook (6). Tighten nut (2).
14. Install clevis (4) on hook (6) with clevis pin (3) and new cotter pin (5).

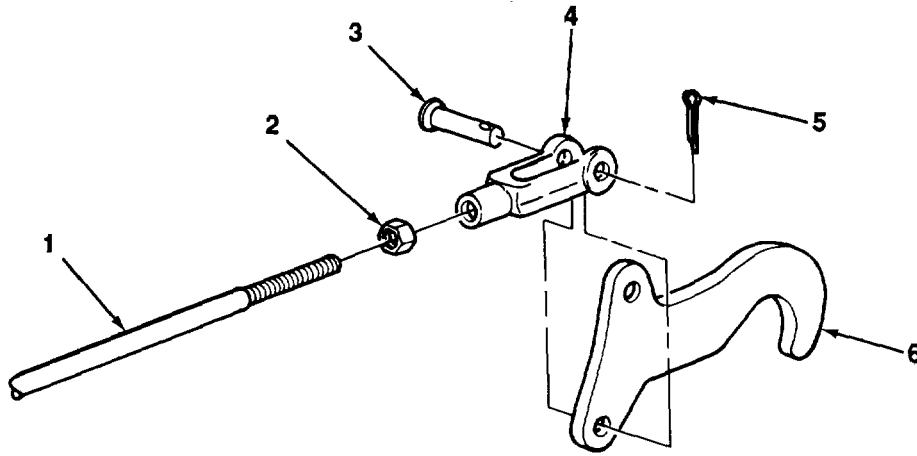

15-28. TAILGATE REPLACEMENT.

This Task Covers:

- a. Removal b. Installation
-

Initial Setup:

Materials/Parts:

- Four cotter pins

Tools/Test Equipment:

- General mechanic's tool kit
- Field automotive shop set

References:

- TM 5-3805-254-10

Personnel Required: Two

a. REMOVAL

1. Using suitable lifting device attached to tailgate (1), raise lifting device just enough to take weight of tailgate off two hinge pins (2).
2. Disconnect two chains (3) from dump body (4) and stow chains on tailgate (1).

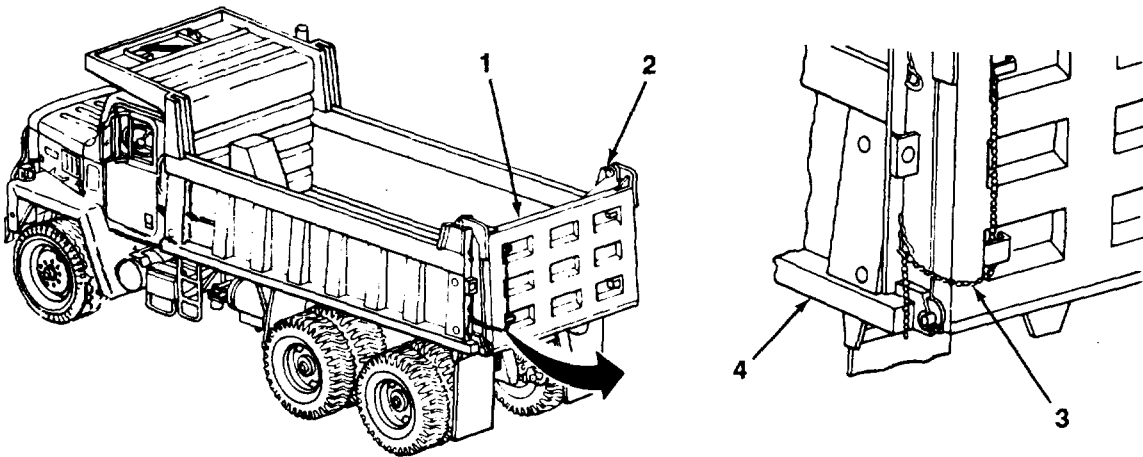

15-28. TAILGATE REPLACEMENT (Con't).**WARNING**

Ensure that all personnel are clear of tailgate as hinge pins are removed, to prevent Injury to personnel.

NOTE

Perform step 3 at left and right side of tailgate.

3. Remove two cotter pins (5) and hinge pins (2) to separate tailgate (1) from dump body (4). Discard cotter pins.
4. Operate tailgate release lever (see TM 5-3805-254-10) to release bottom of tailgate (1) from dump body (4).

WARNING

Ensure that all personnel are clear of tailgate before raising, to prevent Injury to personnel.

5. Move tailgate (1) to storage location and place on secure supports. Remove lifting device.

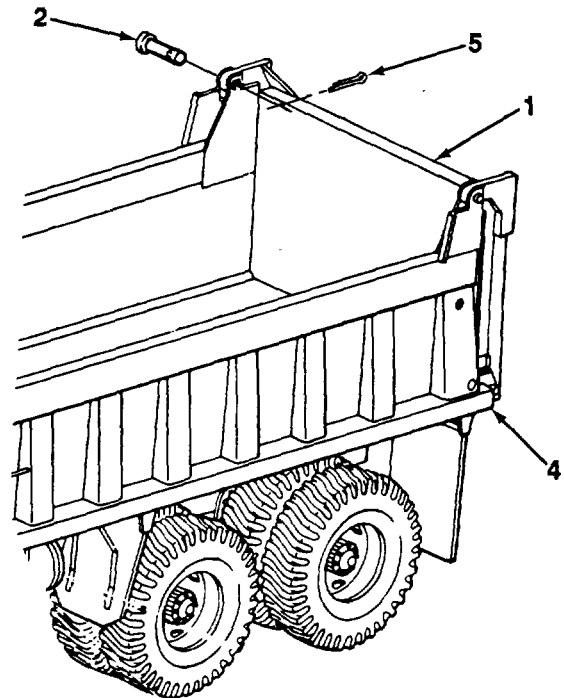
**b. INSTALLATION****WARNING**

Ensure that all personnel are clear of tailgate before raising, to prevent Injury to personnel.

1. Attach lifting device to tailgate (1). Raise tailgate and move to vehicle.

15-28. TAILGATE REPLACEMENT (Con't).

2. Position tailgate (1) to rear of dump body (4) and operate tailgate release lever (TM 5-3805-254-10) to install bottom of tailgate to dump body.

NOTE

Perform step 3 at left and right top of tailgate.

3. Install top of tailgate (1) to dump body (4) with two hinge pins (2) and new cotter pins (5).
4. Remove lifting device.
5. Install two chains (3) to dump body (4).

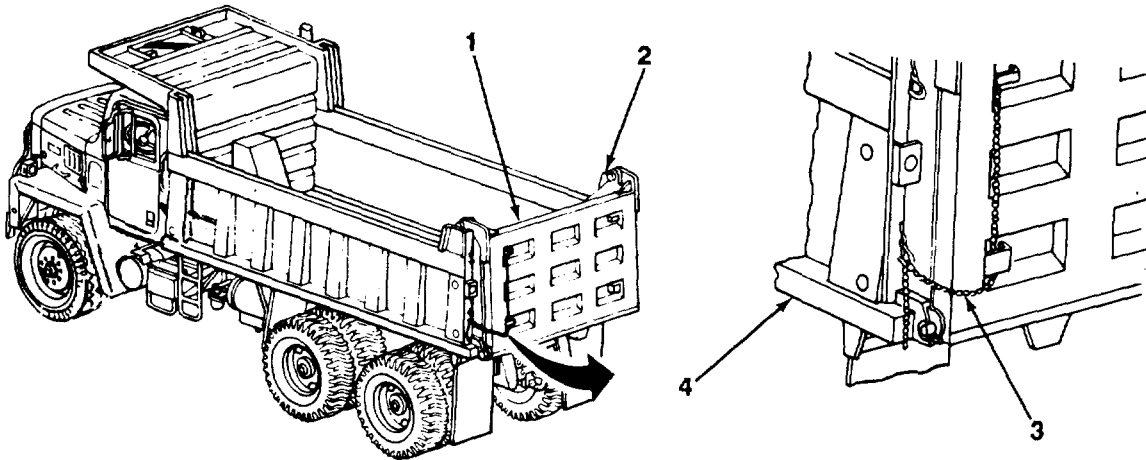

15-29. DRIVER'S SEAT AIR SPRING REPLACEMENT.*This Task Covers:*

a. Removal

b. Installation

*Initial Setup:***Equipment Conditions:**

- Driver's seat removed (see TM 5-3805-254-20).

Tools/Test Equipment:

- General mechanic's tool kit

a. REMOVAL

1. Remove screw (3) from seat base (2).
2. Rotate air spring (4) counterclockwise to remove air spring from elbow (1) of air reservoir (5).

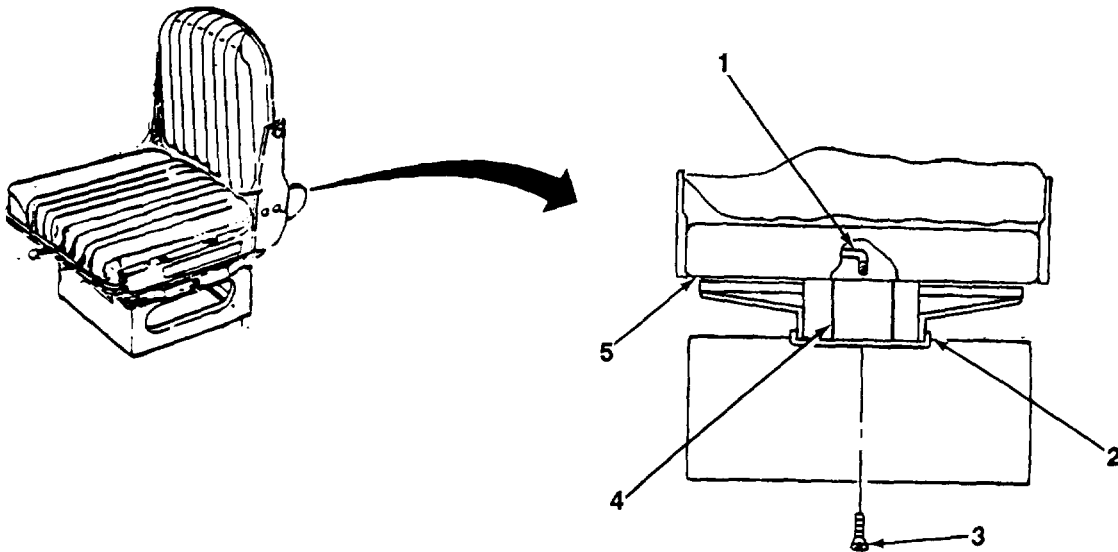
**b. INSTALLATION**

1. Install air spring (4) to elbow (1) of air reservoir (5) by rotating air spring clockwise.
2. Install screw (3) to seat base (2).

FOLLOW-ON TASKS:

- Install driver's seat (see TM 5-3805-254-20).

TA704184

15-30. DRIVER'S SEAT SHOCK ABSORBER REPLACEMENT.*This Task Covers:*

a. Removal

b. Installation

*Initial Setup:***Equipment Conditions:**

- Driver's seat pan removed (see TM 5-3805-254-20).

Tools/Test Equipment:

- General mechanic's tool kit

Materials/Parts:

- One repair kit
- Two spring pins

a. REMOVAL

1. Remove two retaining rings (6) and pin (7) to disconnect front of shock absorber (2) from shock absorber lever (8).

NOTE

Note position of spring pins for assembly.

2. Remove two spring pins (4), pin (5), and shock absorber (2) from lever (3). Discard spring pins.
3. Remove four bushings (1) from shock absorber (2). Discard bushings.

b. INSTALLATION

1. Install four new bushings (1) in shock absorber (2).
2. Install shock absorber (2) to lever (3) with pin (5) and two new spring pins (4).
3. Connect front of shock absorber (2) to shock absorber lever (8) with pin (7) and two retaining rings (6).

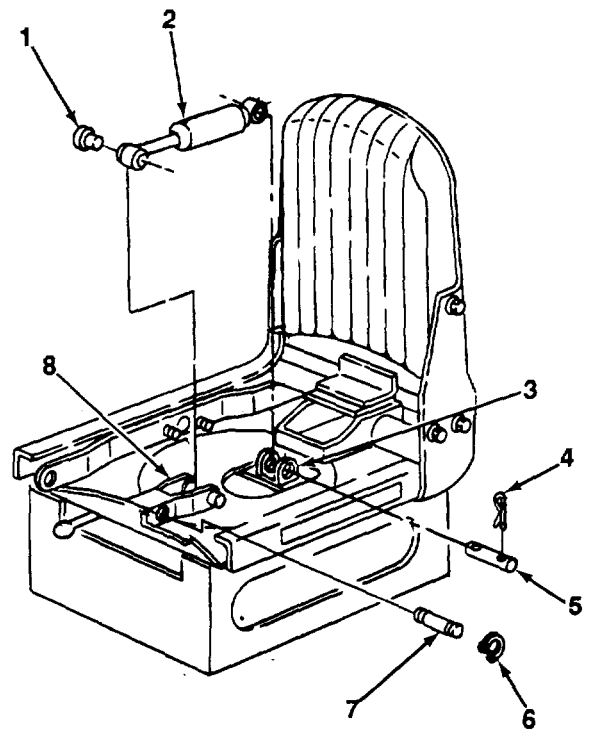
**FOLLOW-ON TASKS:**

- Install driver's seat pan (see TM 5-3805-254-20).

15-31. DRIVER'S SEAT REPAIR.*This Task Covers:*

- | | |
|--|---|
| <ul style="list-style-type: none"> a. Disassembly b. Cleaning and Inspection | <ul style="list-style-type: none"> c. Assembly |
|--|---|

*Initial Setup:***Equipment Conditions:**

- Driver's seat air spring removed (see paragraph 15-29).
- Driver's seat shock absorber removed (see paragraph 15-30).

Tools/Test Equipment:

- General mechanic's tool kit
- Field automotive shop set

Materials/Parts:

- Dry cleaning solvent (Item 23, Appendix B)
- Nine lockwashers

General Safety Instructions:

- Dry cleaning solvent is flammable and must not be used near open flame. Use only in a well-ventilated area.

[a. DISASSEMBLY

1. Remove nipple (6) from air valve (5).
2. Remove air hose (9) and two spring clips (8) from adapter (10) and adapter (7).
3. Remove screw (1), knob (2), jamnut (3), and lockwasher (4) from air valve (5). Discard lockwasher.
4. Remove air valve (5).

NOTE**Note position of elbow for assembly.**

5. Remove adapter (10) and elbow (11) from air valve (5).

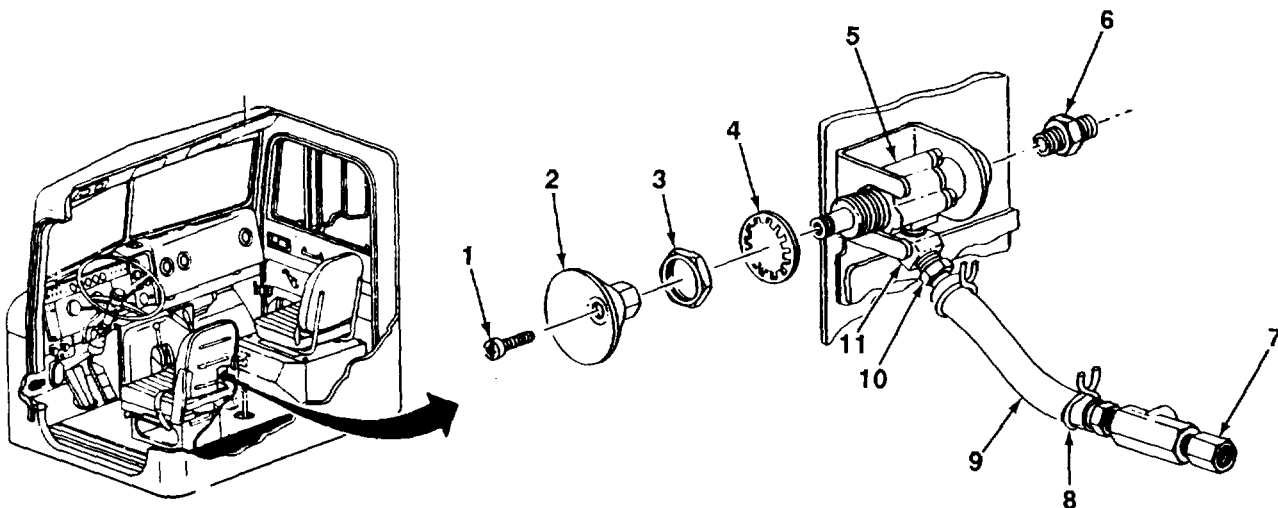

15-31. DRIVER'S SEAT REPAIR (Con't).

6. Remove two nuts (13), lockwashers (14), bolt (18), and four spacer washers (17) holding rear c seat base (15) to seat adjuster (16). Discard lockwashers.
7. Remove two nuts (12), lockwashers (22), washer (21), seat adjuster (16), and four spacer washer (20) from front of seat base (15). Discard lock washers.
8. Remove two loose bolts (19) from front of see adjuster (16).

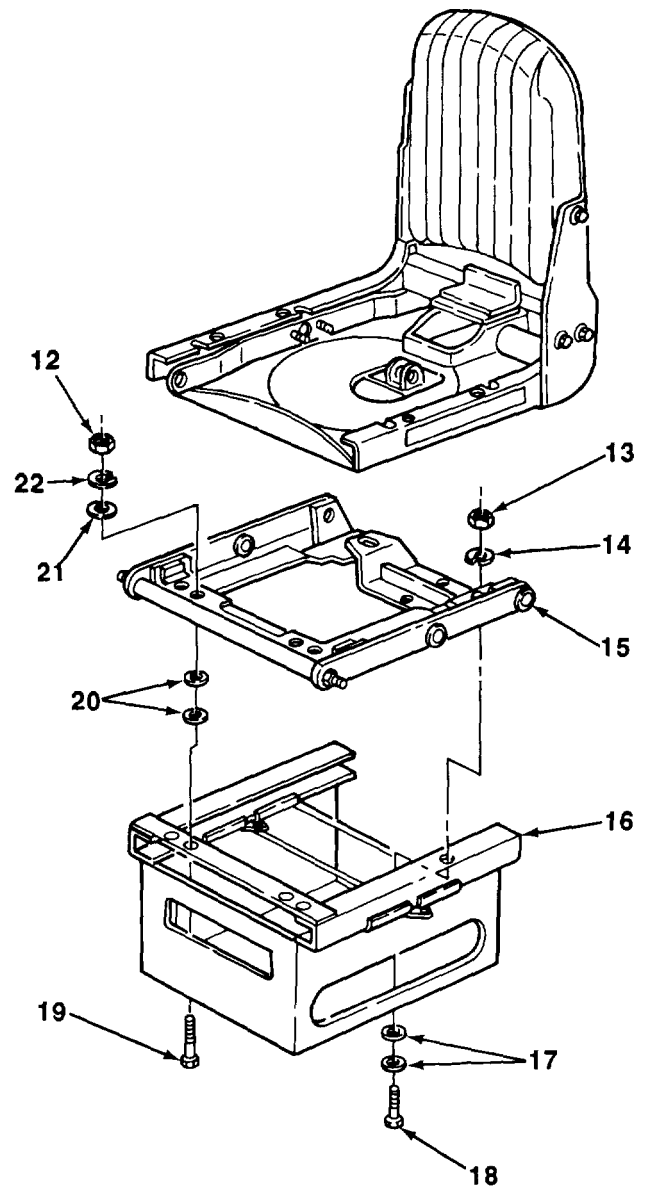

15-31. DRIVER'S SEAT REPAIR (Con't).

9. Remove two retaining rings (26), hinge pins (24), washers (25), and seat base (15) from seat adjuster lever (23).

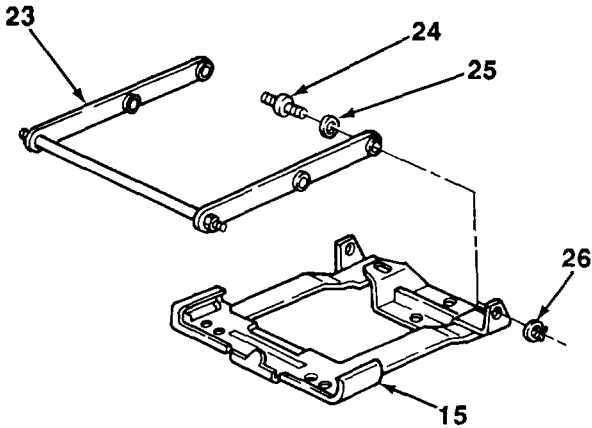

10. Remove two retaining rings (27), hinge pin (28), and lever (29) from seat base (15).

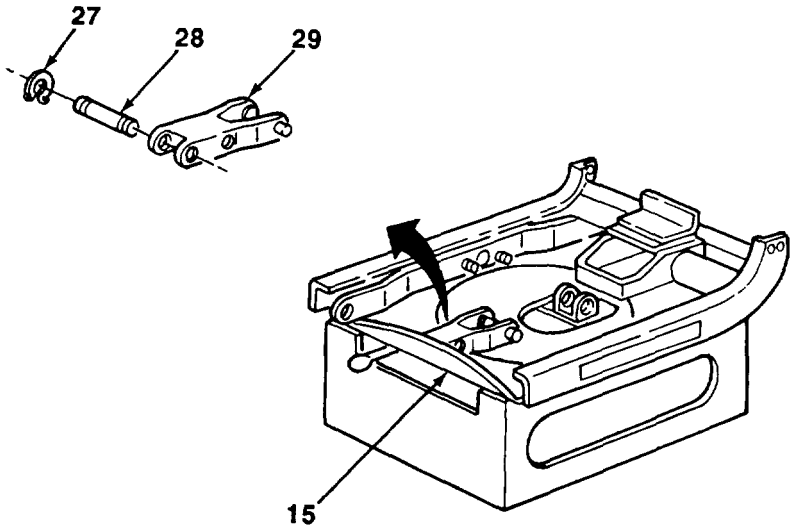

NOTE

Note position of lubrication fitting at center of seat adjuster lever for assembly.

11. Remove two retaining rings (32), pins (30), washers (31), and seat adjuster lever (23) from seat (33).

15-31. DRIVER'S SEAT REPAIR (Con't).

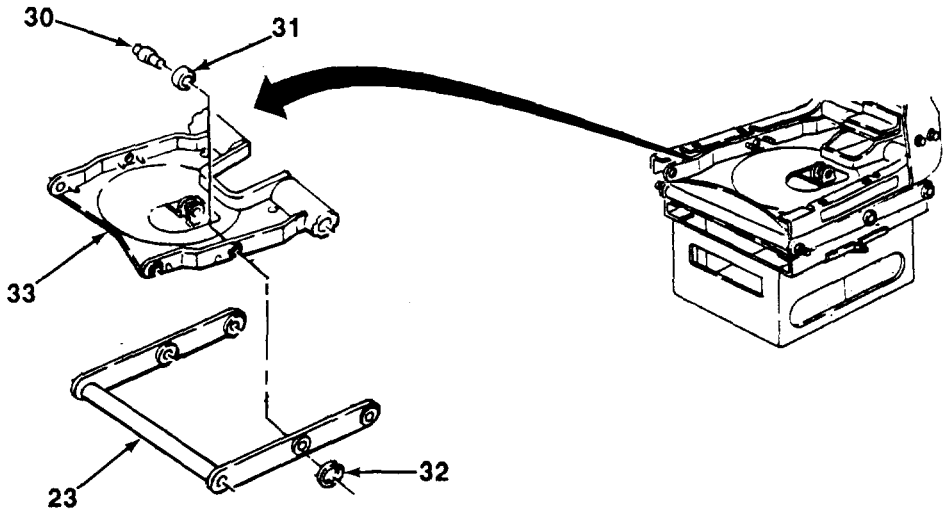

- 12. Remove two retaining rings (35), rollers (36), and washers (37) from seat adjuster lever (23).
- 13. Remove four bushings (34) from seat adjuster lever (23).
- 14. Remove four bolts (41), lockwashers (42), two seat panels (38 and 40), and air reservoir (39) from seat (33). Discard lockwashers.

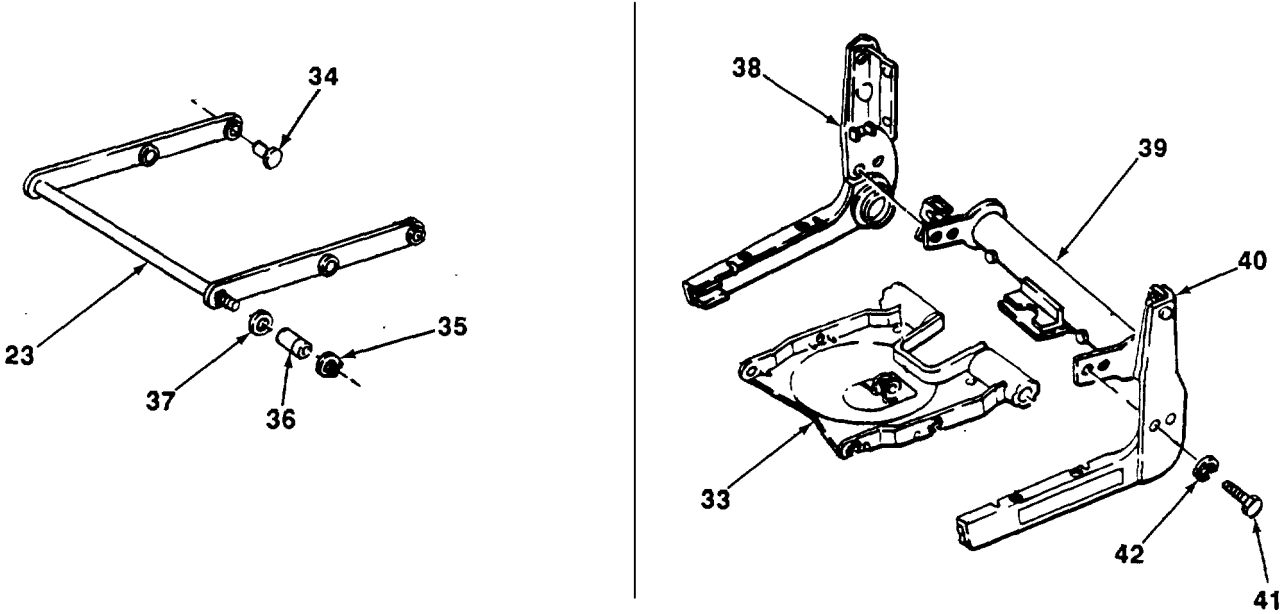

15-31. DRIVER'S SEAT REPAIR (Con't).

- 15. Remove adapter (7) and relief valve (45) from air reservoir (39).
- 16. Remove air hose (44) and two spring clamps (43) from air reservoir (39).

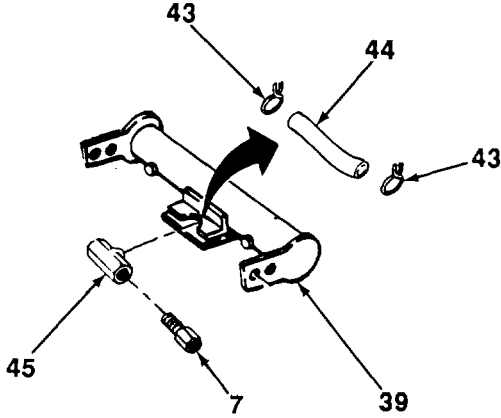

NOTE

Note position of ride indicator for assembly.

- 17. Remove two bushings (46) and ride indicator (47) from seat (33).
- 18. Remove two retaining rings (48), rollers (49), washers (50), and pins (51) from seat (33).

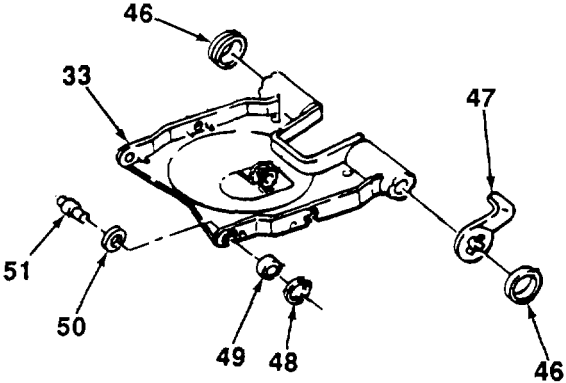

- 19. Remove two rubber bushings (52) from seat (33).

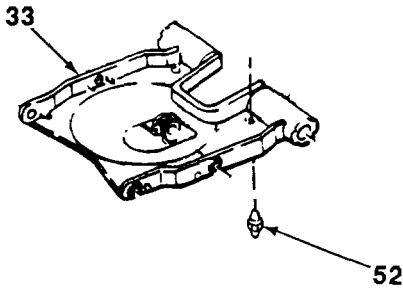

15-31. DRIVER'S SEAT REPAIR (Con't).

20. Remove four nuts (55) and washers (56) from riser (54).
21. Remove seat adjuster (16) and four spacers (53) from riser (54).

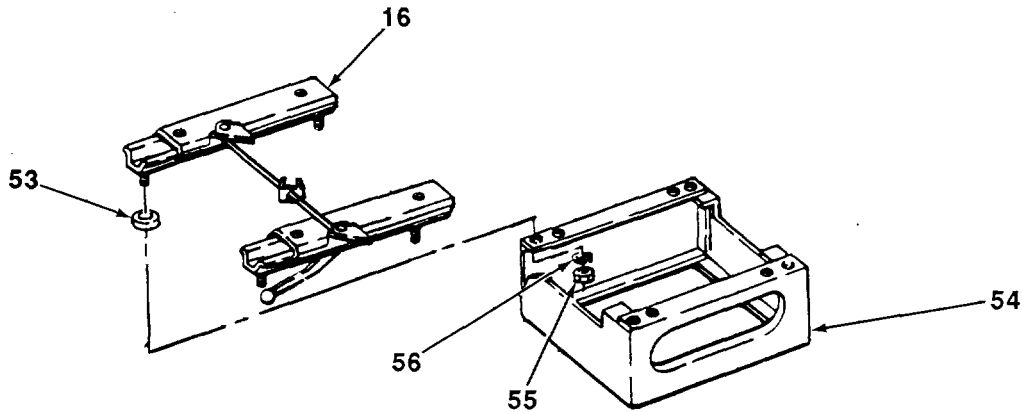
**b. CLEANING AND INSPECTION****WARNING**

Dry cleaning solvent, P-D-680, is toxic and flammable. Always wear protective goggles and gloves, and use only in a well-ventilated area. Avoid contact with skin, eyes, and clothes, and DO NOT breathe vapors. DO NOT use near open flame or excessive heat. The solvent's flash point is 100°F-138°F (380C-590C). If you become dizzy while using cleaning solvent, Immediately get fresh air and medical help. If solvent contacts eyes, Immediately wash your eyes and get medical aid.

1. Clean metal parts with dry cleaning solvent.
2. Inspect metal parts for cracks, breaks, corrosion, and other damage. Replace damaged parts.
3. Inspect lubrication fittings for damage. Replace if damaged.

c. ASSEMBLY

1. Aline seat adjuster (16) and four spacers (53) with riser (54) and install four washers (56) and nuts (55).
2. Install two rubber bushings (52) on seat (33).
3. Install two pins (51), washers (50), rollers (49), and retaining rings (48) to seat (33).
4. Install ride indicator (47) and two bushings (46) to seat (33).

TA704191

15-31. DRIVER'S SEAT REPAIR (Con't).

5. Install air hose (44) and two spring clamps (43) to air reservoir (39).
6. Install relief valve (45) and adapter (7) to air reservoir (39).

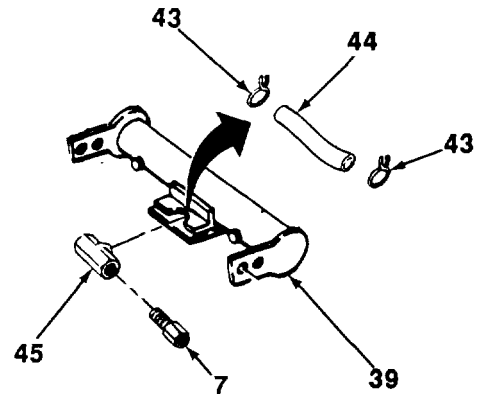

7. Install two seat panels (38 and 40) and air reservoir (39) to seat (33) with four new lockwashers (42) and bolts (41).

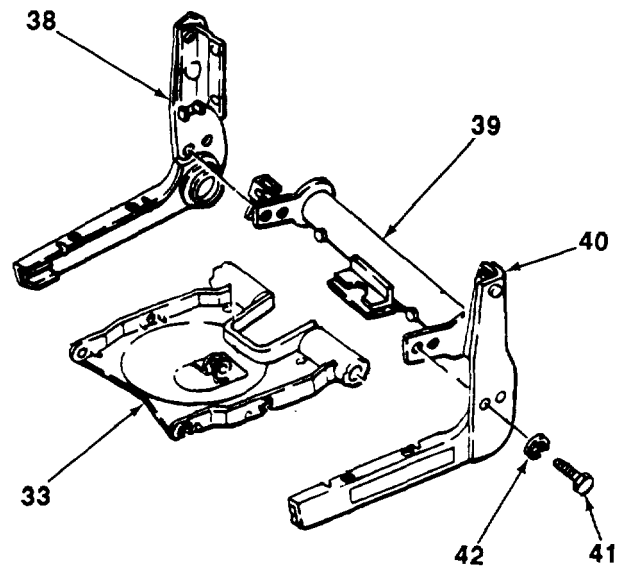

15-31. DRIVER'S SEAT REPAIR (Con't).

- 8. Install four bushings (34) in seat adjuster lever (23).
- 9. Install two washers (37), rollers (36), and retaining rings (35) on seat adjuster lever (23).

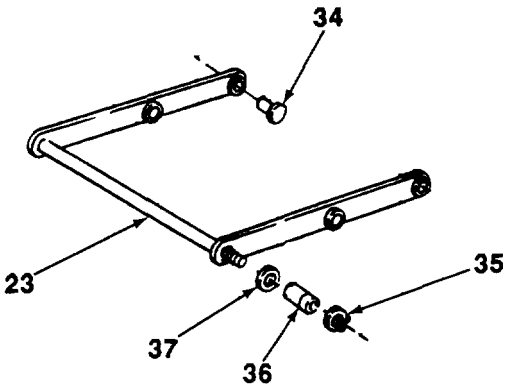

NOTE

Ensure that two rollers of seat adjuster lever are placed into slots of seat panels and that lubrication fitting at center of seat adjuster is facing seat.

- 10. Install seat adjuster lever (23) to seat (33) with two washers (31), pins (30), and retaining rings (32).

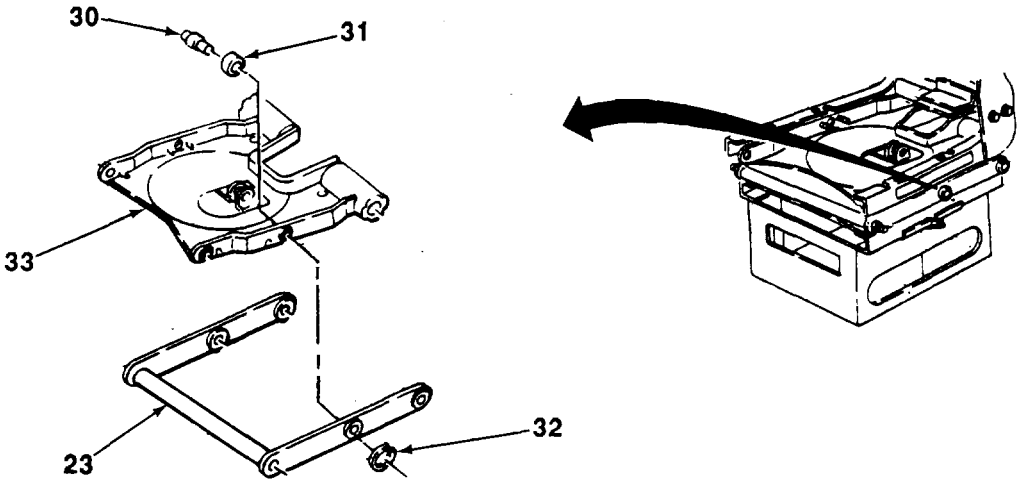

15-31. DRIVER'S SEAT REPAIR (Con't).

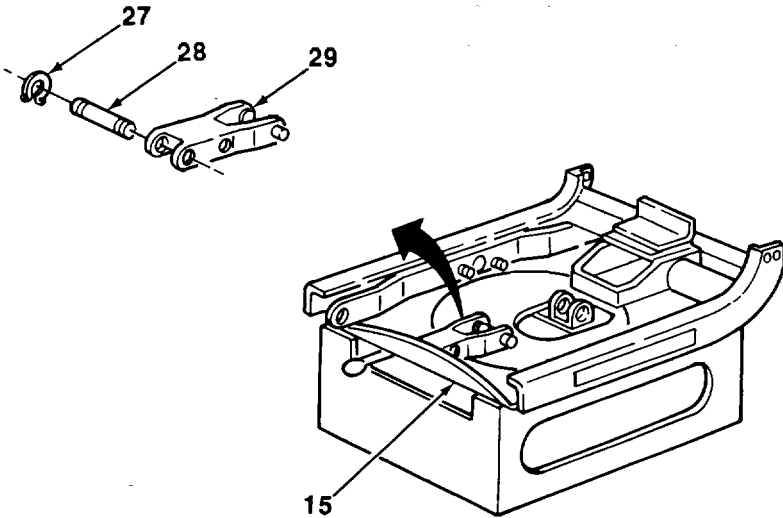

NOTE

Ensure that two rollers of seat adjuster lever are placed into slot of seat base.

- 12. Install seat base (15) to seat adjuster lever (23) with two washers (25), hinge pins (24), and retaining rings (26).

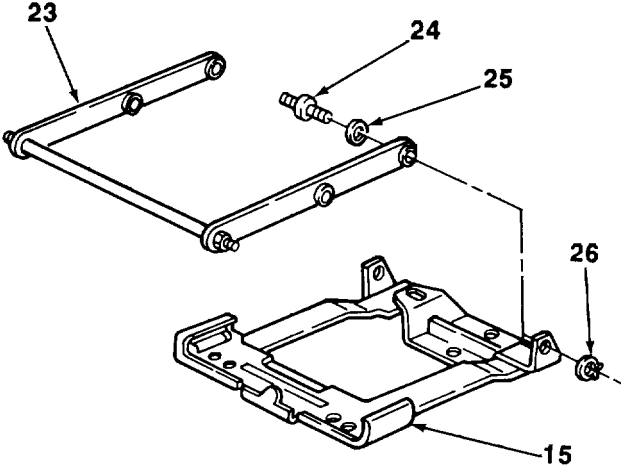

15-31. DRIVER'S SEAT REPAIR (Con't).

- 13. Loosely install two bolts (19) to front of seat adjuster (16).
- 14. Install four spacer washers (20) and seat adjuster (16) to front of seat base (15) with two bolts (19), washers (21), new lockwashers (22), and nuts (12).
- 15. Install four spacer washers (17) and seat adjuster (16) to rear of seat base (15) with two bolts (18), new lockwashers (14), and nuts (13).

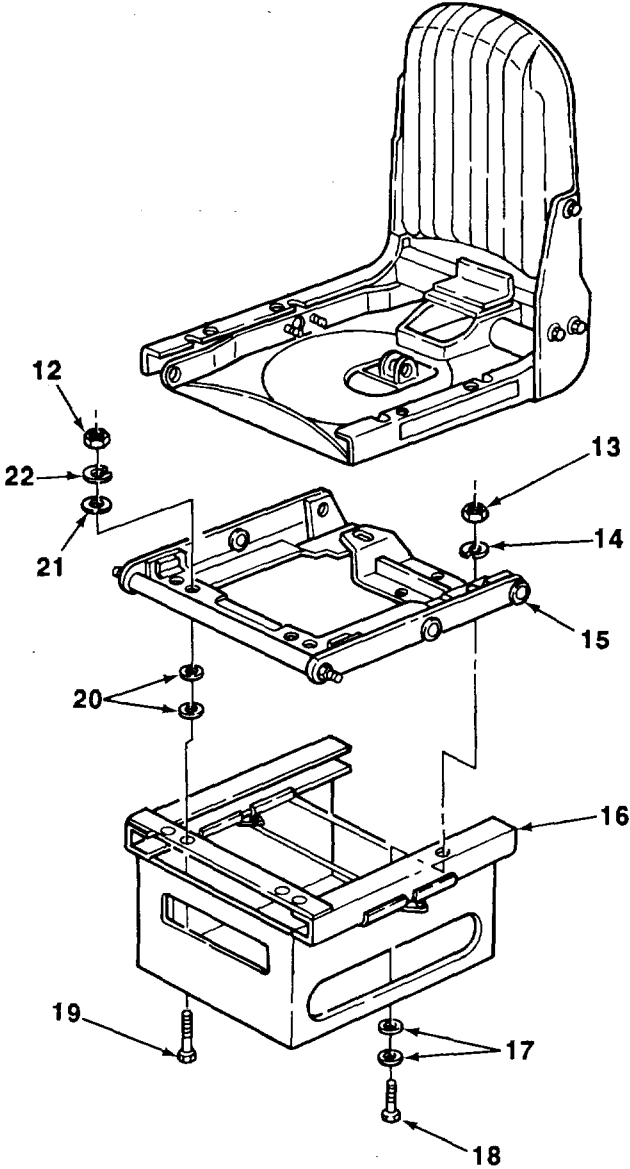

15-31. DRIVER'S SEAT REPAIR (Con't).

16. Install elbow (11) and adapter (10) to air valve (5).
17. Install air valve (5) with new lockwasher (4) and jamnut (3).
18. Install knob (2) to air valve (5) with screw (1).
19. Install air hose (9) to adapter (10) and adapter (7) with two spring clips (8).
20. Install nipple (6) in air valve (5).

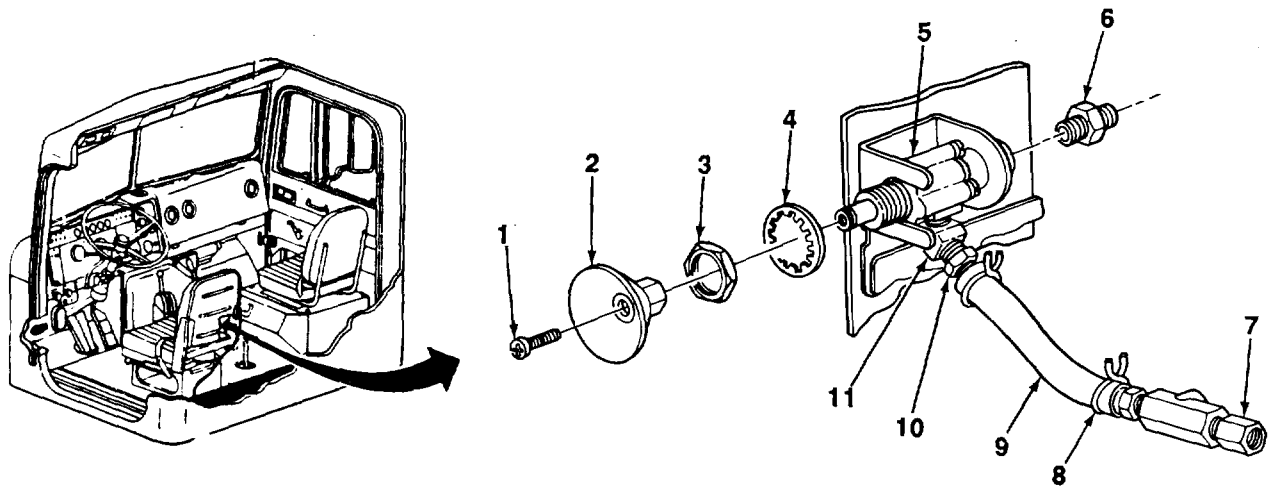
**FOLLOW-ON TASKS:**

- Install driver's seat shock absorber (see paragraph 15-30).
- Install driver's seat air spring (see paragraph 15-29).

TA704196

15-32. HEATER FAN MOTOR REPLACEMENT.

This Task Covers:

a. Removal

b. Installation

Initial Setup:

Equipment Conditions:

- Passenger's seat removed (see TM 5-3805-254-20)

Tools/Test Equipment:

- General mechanic's tool kit
- Field automotive shop set

Materials/Parts:

- Two gaskets
 - Five locknuts
-

a. REMOVAL

1. Remove six screws (1), cover (2), and seal (3) from top of heater box (4).

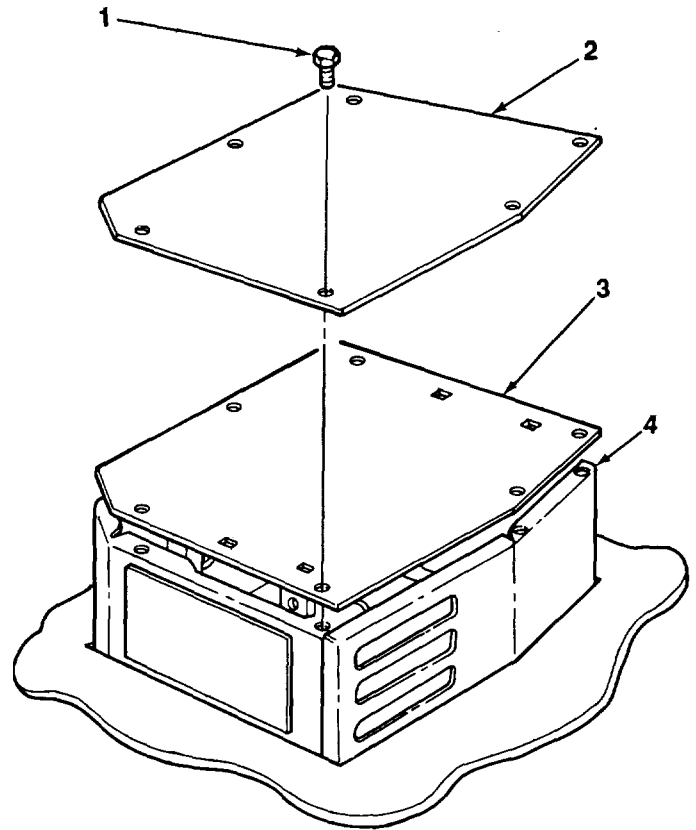

15-32. HEATER FAN MOTOR REPLACEMENT (Con't).

NOTE
Both heater fan motors are removed in the same manner.

- 2. Remove three screws (5) and plate (6) from housing (7).
- 3. Disconnect motor wire (10).
- 4. Remove three locknuts (11), motor (8), housing (7), and gasket (9) from heater box (4). Discard locknuts and

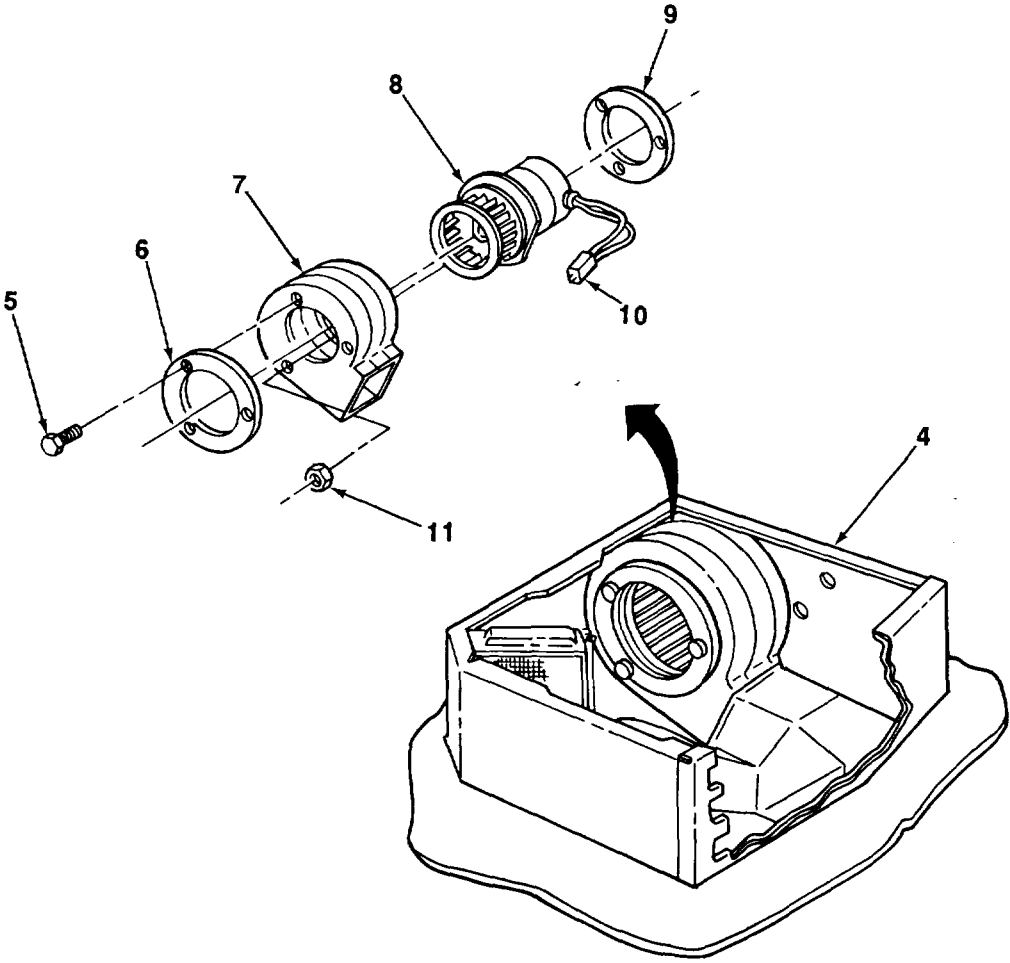

15-32. HEATER FAN MOTOR REPLACEMENT (Con't).

5. Loosen setscrew (13) and remove blower wheel (14) from motor shaft (17).
6. Remove two locknuts (12), plate (15), and gasket (16) from motor (8). Discard locknuts and gasket.
7. Repeat steps 2 through 6 for other heater fan motor.

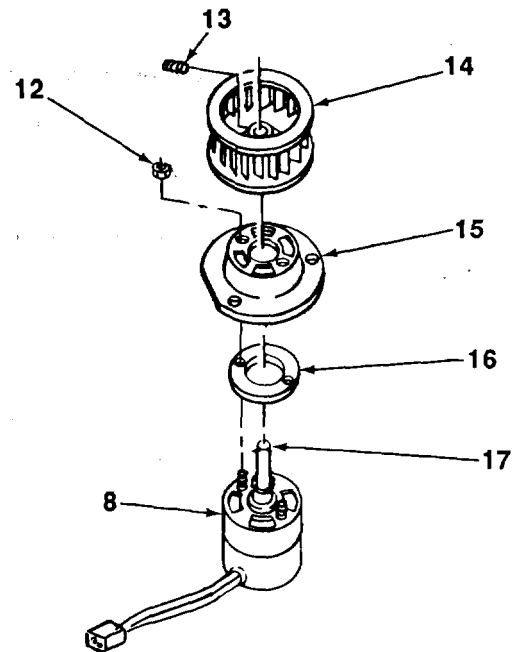
**b. INSTALLATION****NOTE**

Both heater fan motors are installed in the same manner.

1. Install new gasket (16) and plate (15) on motor (8) with two new locknuts (12).
2. Position blower wheel (14) on motor shaft (17) and tighten setscrew (13).
3. Install new gasket (9), housing (7), and motor (8) on heater box (4) with three new locknuts (11).
4. Connect motor wire (10).
5. Install plate (6) on housing (7) with three screws (5).
6. Repeat steps 1 through 5 to install other heater fan motor, if removed.

TA704199

15-32. HEATER FAN MOTOR REPLACEMENT (Con't).

7. Install seal (3) and cover (2) on heater box (4) with six screws (1).

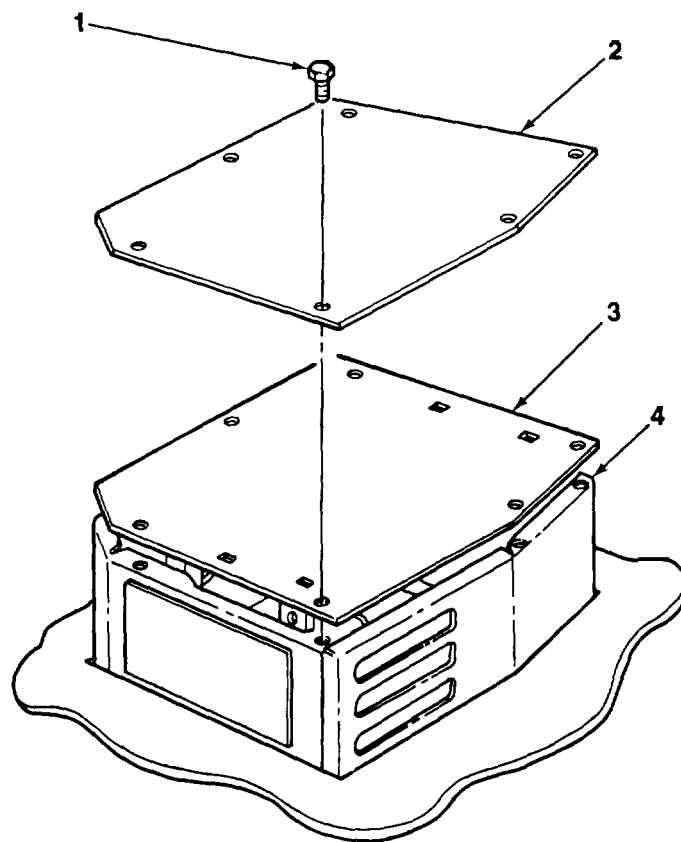
**FOLLOW-ON TASKS:**

- Install passenger's seat (see TM 5-3805-254-20).

15-33. HEATER CORE AND BRACKET REPLACEMENT.

This Task Covers:

- a. Removal
- b. Installation

Initial Setup:

Equipment Conditions:

- Cover and seal removed from heater box (see paragraph 15-32).

Tools/Test Equipment:

- General mechanic's tool kit

Materials/Parts:

- Adhesive (Item 1, Appendix B)
- One washer
- Two seals
- Seven locknuts

a. REMOVAL

1. Loosen clamp (11) and remove hose (10) from heater core (1).
2. Remove six locknuts (4), screws (5), and heater core (1) from bracket (7) and heater box (6). Discard locknuts.
3. If damaged, remove and discard two seals (2) from heater core (1).
4. Remove locknut (8), screw (9), and support from heater box (6). Discard locknut.

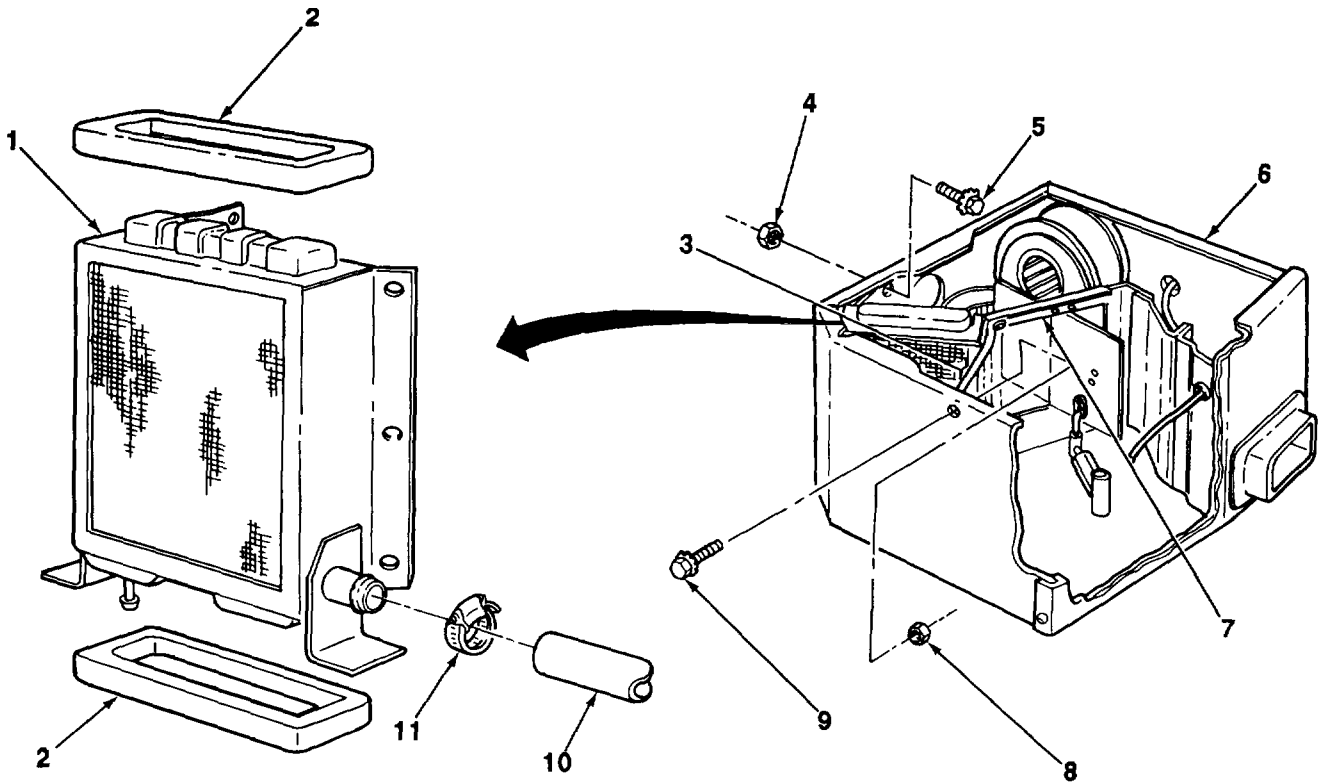

15-33. HEATER CORE AND BRACKET REPLACEMENT (Con't).

- 5. Remove washer (19) and control assembly (15) from door (12). Discard washer.
- 6. Remove four spring pins (16), eight washers (17), and adjusting rod (18).
- 7. Remove three screws (13), nuts (14), and bracket (7) from heater box (6).

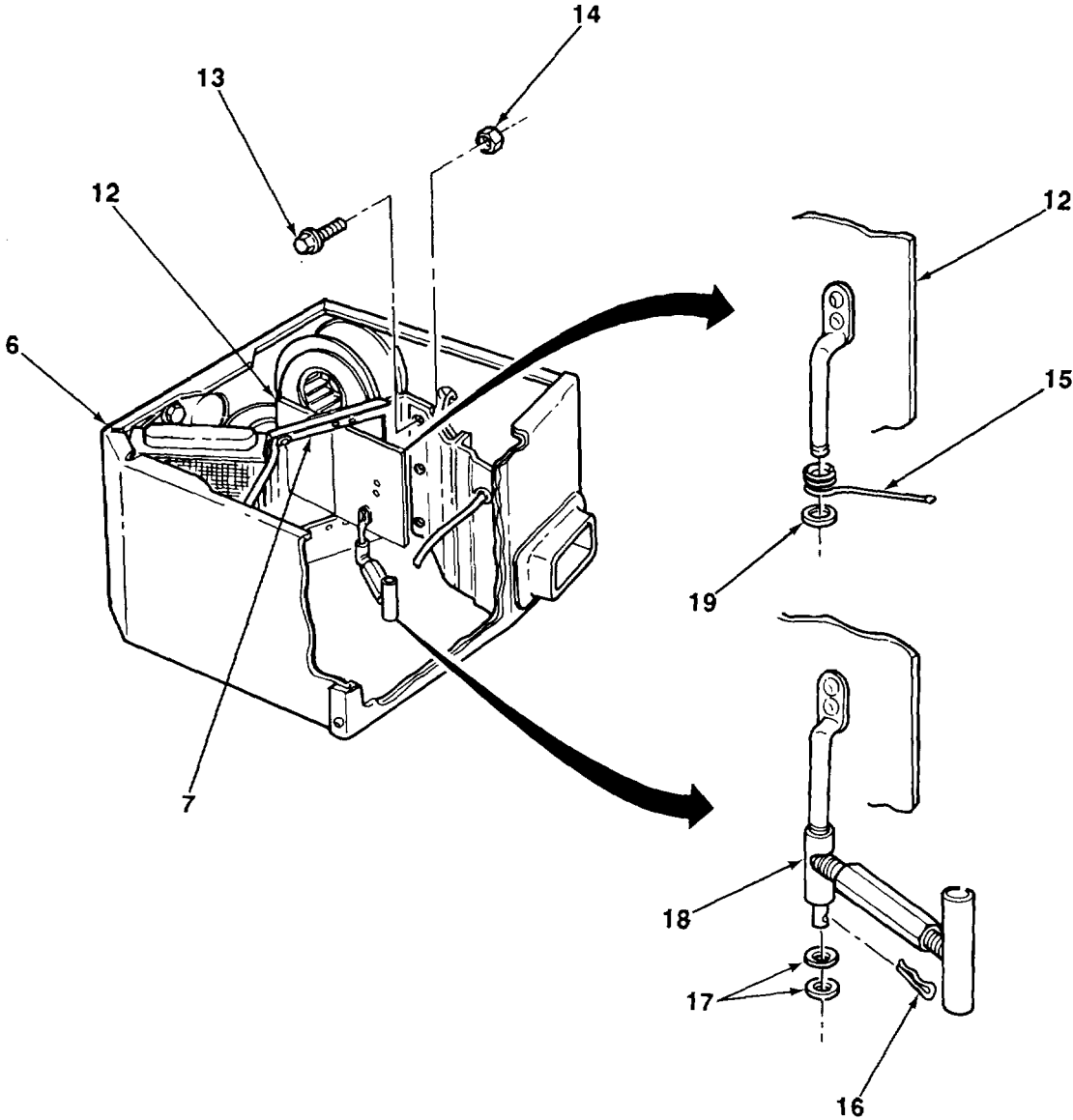

15-33. HEATER CORE AND BRACKET REPLACEMENT (Con't).

8. Remove four screws (22), nuts (20) two pivots (21), and door (12) from bracket (7).
9. If damaged, remove two seals (23) from door (12). Discard seals.

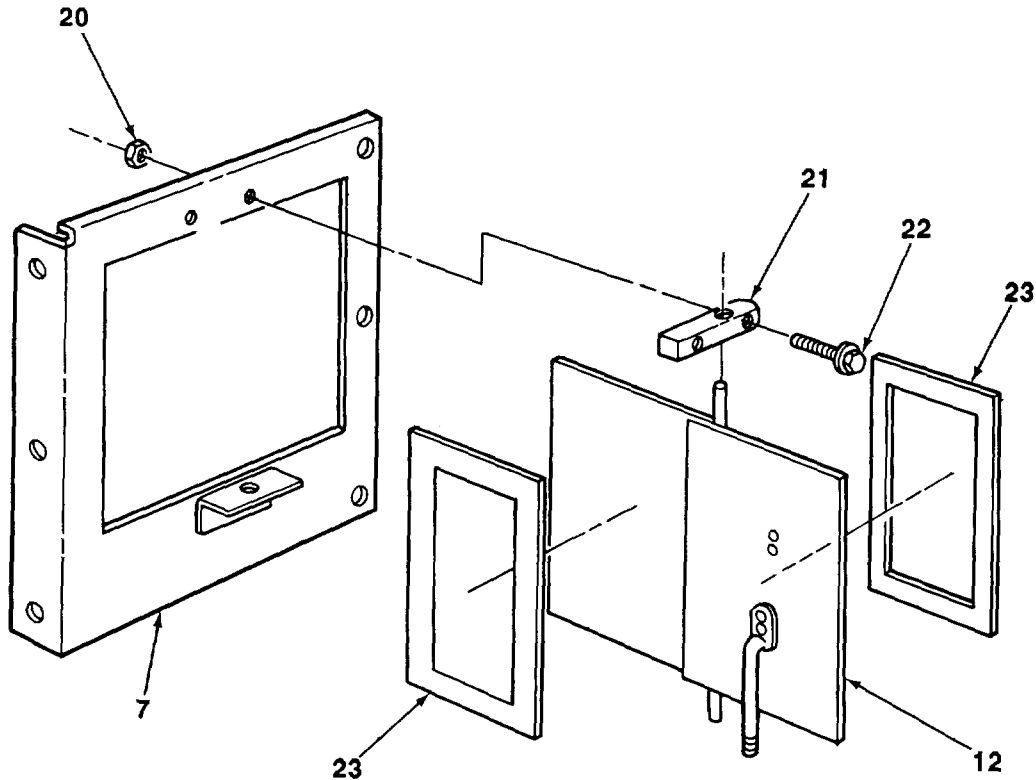
**b. INSTALLATION**

1. If removed, apply adhesive to two new seals (23) and install on door (12). Wipe off excess adhesive.
2. Install door (12) and two pivots (21) on bracket (7) with four screws (22) and nuts (20).
3. Install bracket (7) in heater box (6) with three screws (13) and nuts (14).
4. Install adjusting rod (18) with eight washers (17) and four spring pins (16).
5. Install control assembly (15) on door (12) with new washer (19).

TA704203

15-33. HEATER CORE AND BRACKET REPLACEMENT (Con't).

6. If removed, install two new seals (2) on heater core (1).
7. Install heater core (1) on bracket (7) and heater box (6) with six screws (5) and new locknuts (4).
8. Install other end of support (3) on heater box (6) with screw (9) and new locknut (8).
9. Position hose (10) on heater core (1) and tighten clamp (11).

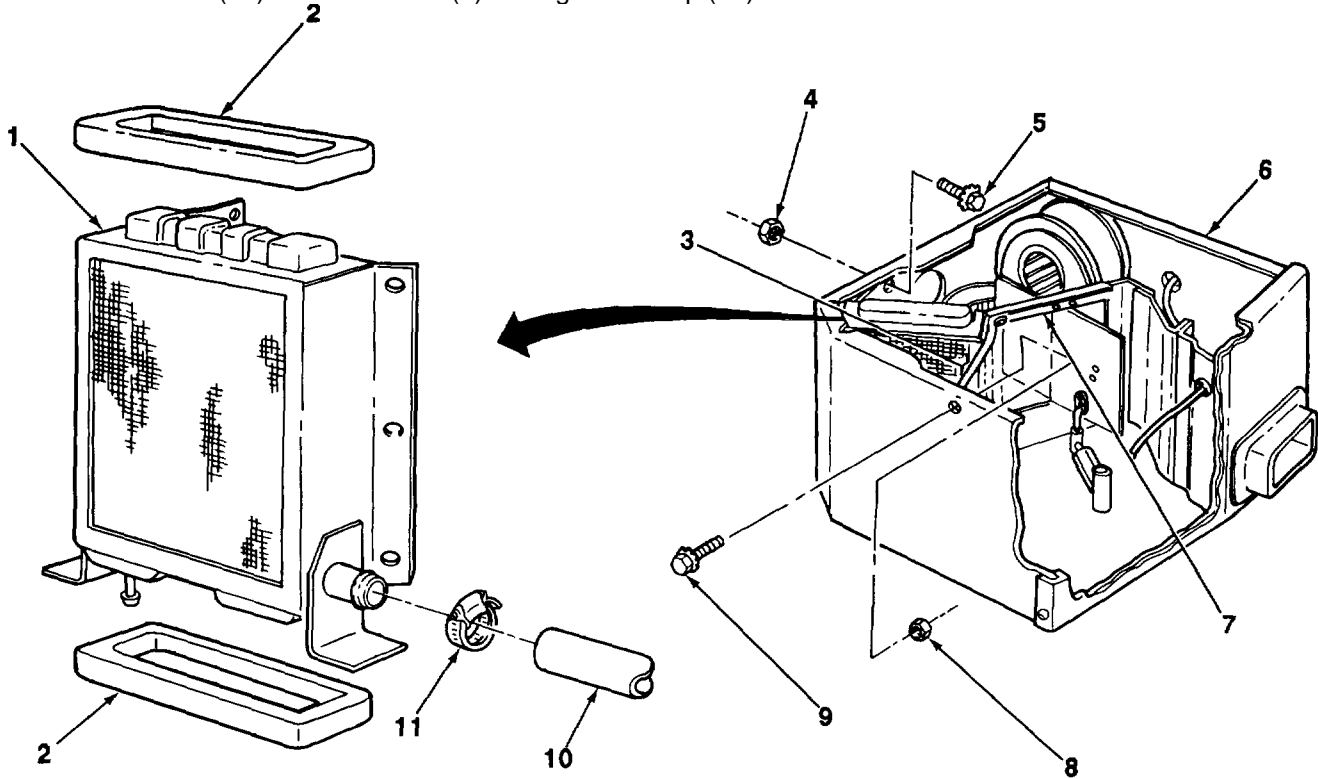
**FOLLOW-ON TASKS:**

- Install cover and seal on heater box (see paragraph 15-32).

TA704204

15-34. HEATER CONTROL AND CONTROL PANEL REPLACEMENT.

This Task Covers:

a. Removal

b. Installation

Initial Setup:

Equipment Conditions:

- Batteries disconnected (see TM 5-3805-254-20).

Tools/Test Equipment:

- General mechanic's tool kit

Materials/Parts:

- Four locknuts
- Four pushnuts

a. REMOVAL

1. Remove setscrew (3) and knob (4).
2. Remove two setscrews (6) and two control knobs (5).
3. Remove four screws (8), plate (7), escutcheon (9), and reflector plate (10) from control bracket (11).
4. Pull control bracket (11) part way out of control panel (13) and disconnect two connectors (1 and 2) from two

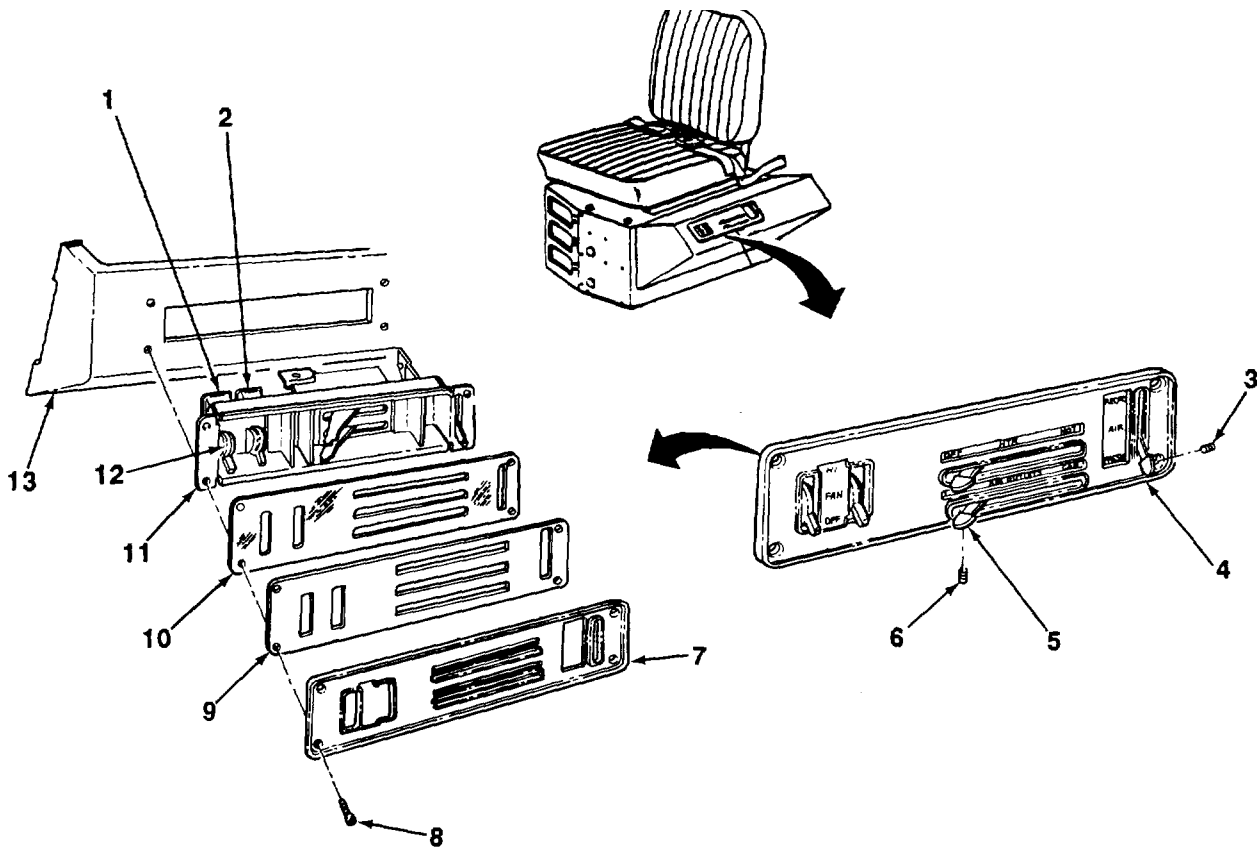

15-34. HEATER CONTROL AND CONTROL PANEL REPLACEMENT-(Con't).

5. Remove four pushnuts (14) and control linkages (15) from control bracket (11). Discard pushnuts.
6. Remove four screws (16) and two switches (12) from control bracket (11).

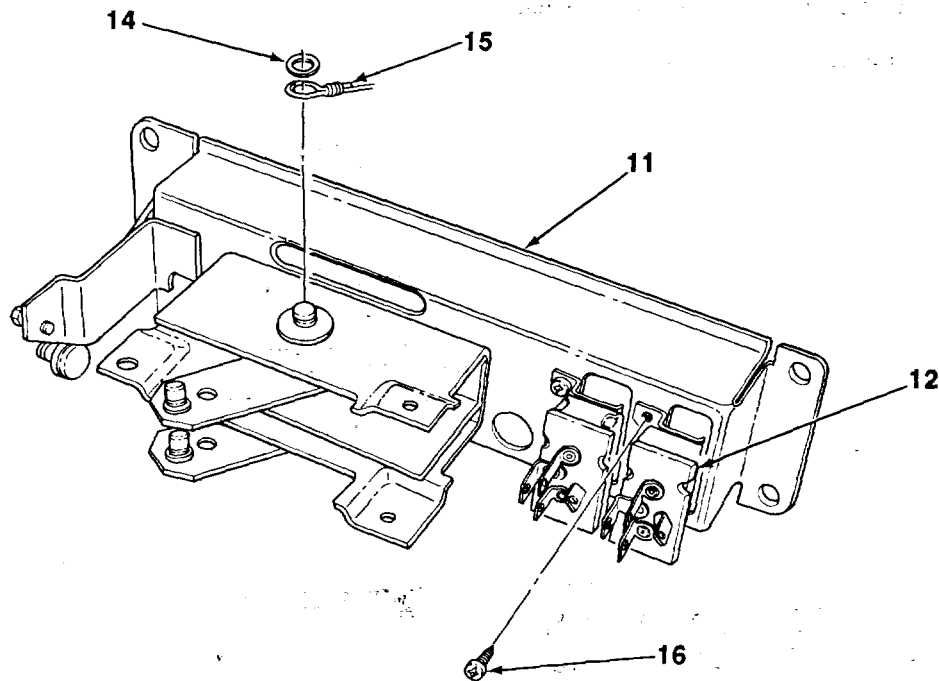

7. Remove six screws (17) and panel (18) from control panel (13).
8. Remove cover from heater box (19) (see paragraph 15-32).
9. Remove four locknuts (20) and control panel (13) from heater box (19). Discard locknuts.

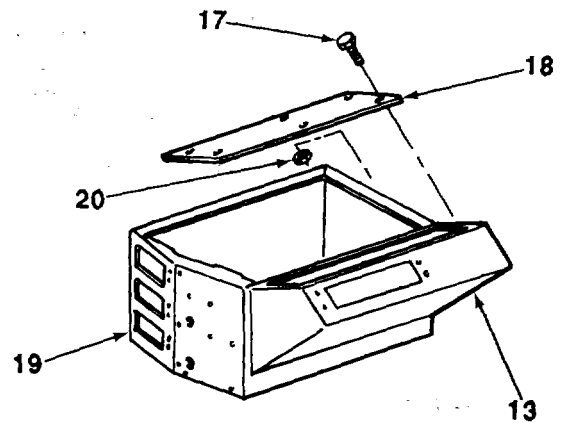

b. INSTALLATION

1. Install control panel (13) to heater box (19) with four new locknuts (20).
2. Install cover on heater box (19) (see paragraph 15-32).
3. Install panel (18) to control panel (13) with six screws (17).
4. Install two switches (12) to control bracket (11) with four screws (16).
5. Install four control linkages (15) to control bracket (11) with four new pushnuts (14).

15-34. HEATER CONTROL AND CONTROL PANEL REPLACEMENT (Con't).

6. Connect two connectors (1 and 2) to two switches (12).
7. Install reflector plate (10), escutcheon (9), plate (7), and control bracket (11) to control panel (13) with four screws (8).
8. Install two control knobs (5) with two setscrews (6).
9. Install knob (4) with setscrew (3).

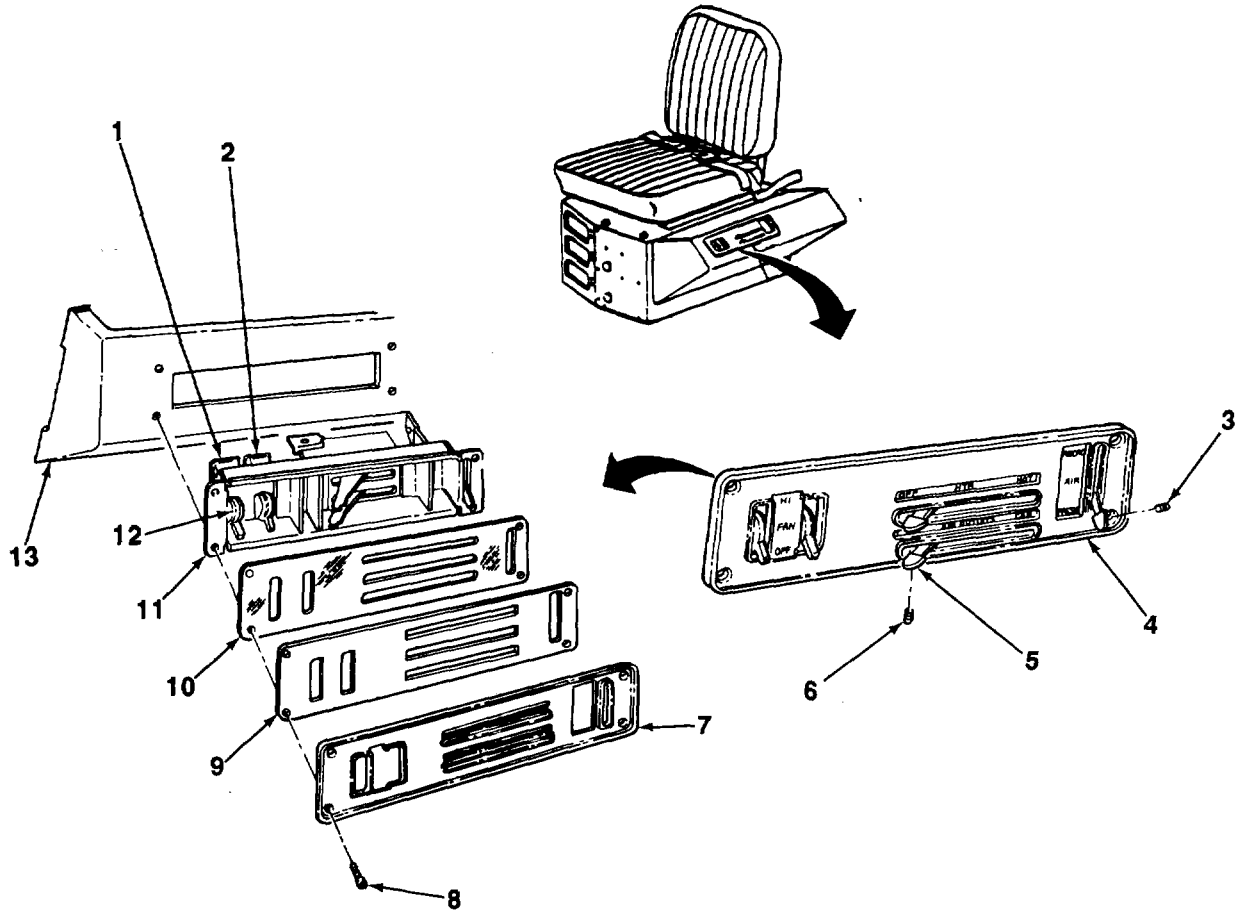

FOLLOW-ON TASKS:

- Connect batteries (see TM 5-3805-254-20).

15-35. HEATER BOX REPLACEMENT.

This Task Covers:

a. Removal

b. Installation

Initial Setup:

Equipment Conditions:

- Heater core and bracket removed (see paragraph 15-33).
- Heater fan motors removed (see paragraph 15-32).
- Heater control and control panel removed (see paragraph 15-34).

Personnel Required: Two

Materials/Parts:

- Adhesive (Item 1, Appendix B)
- Four rivets

Tools/Test Equipment:

- General mechanic's tool kit

a. REMOVAL

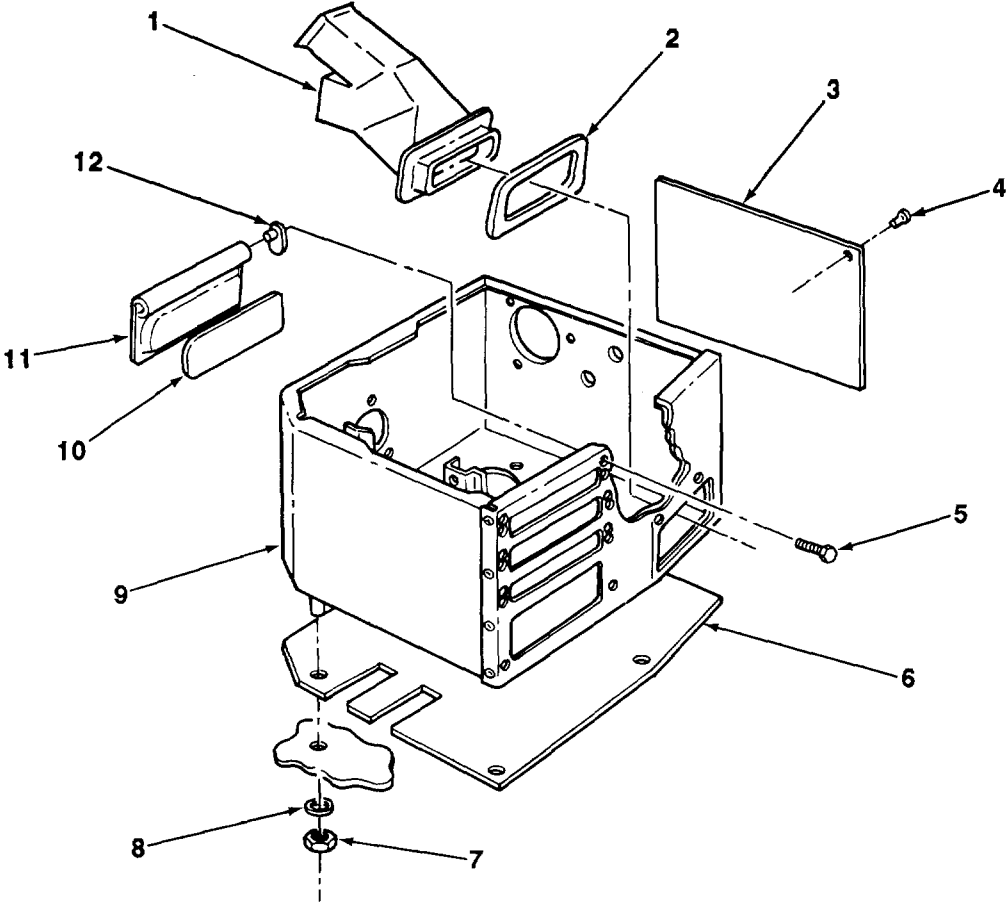

15-35. HEATER BOX REPLACEMENT (Con't).

2. Remove 12 screws (5), six door pivots (12), and three doors (11) from heater box (9).
3. Remove seals (10) from doors (11) only if replacement is necessary.
4. Remove four nuts (7), spacers (8), heater box (9), and insulator (6) from vehicle.
5. Remove four rivets (4) and insulator (3) from heater box (9). Discard rivets.

b. INSTALLATION

1. Install insulator (3) to heater box (9) with four new rivets (4).
2. Install heater box (9) and insulator (6) to vehicle with four spacers (8) and nuts (7).
3. Install seals (10) to doors (11), if removed, using adhesive.
4. Install three doors (11) to heater box (9) with six door pivots (12) and 12 screws (5).
5. Install seal (2) and air duct (1).

FOLLOW-ON TASKS:

- Install heater control and control panel (see paragraph 15-34).
- Install heater fan motors (see paragraph 15-32).
- Install heater core and bracket (see paragraph 15-33).

15-36. DUMP BODY REPLACEMENT.

This Task Covers:

a. Removal

Initial Setup:

Equipment Conditions:

- Tailgate release lever and linkage removed (see paragraph 15-27).
- Dump body control lever and linkage removed (see TM 5-3805-254-20).
- Tailgate removed (see paragraph 15-28).
- Dump body marker lights removed (see TM 5-3805-254-20).
- Pioneer tool rack removed (see TM 5-3805-254-20).
- Body wiring harness removed (see paragraph 5-6).

Personnel Required: Two

b. Installation

Materials/Parts:

- Two cotter pins

Tools/Test Equipment:

- General mechanic's tool kit
- Field automotive shop set
- Welder's tool kit
- Field welding shop set

References:

- TM 9-237
-

a. REMOVAL

NOTE

Perform steps 1 and 2 to remove each of two safety props from dump body.

1. Remove locking lever (4) from dump body (2) to free end of safety prop (3).
2. Remove bolt (1) and safety prop (3) from dump body (2).

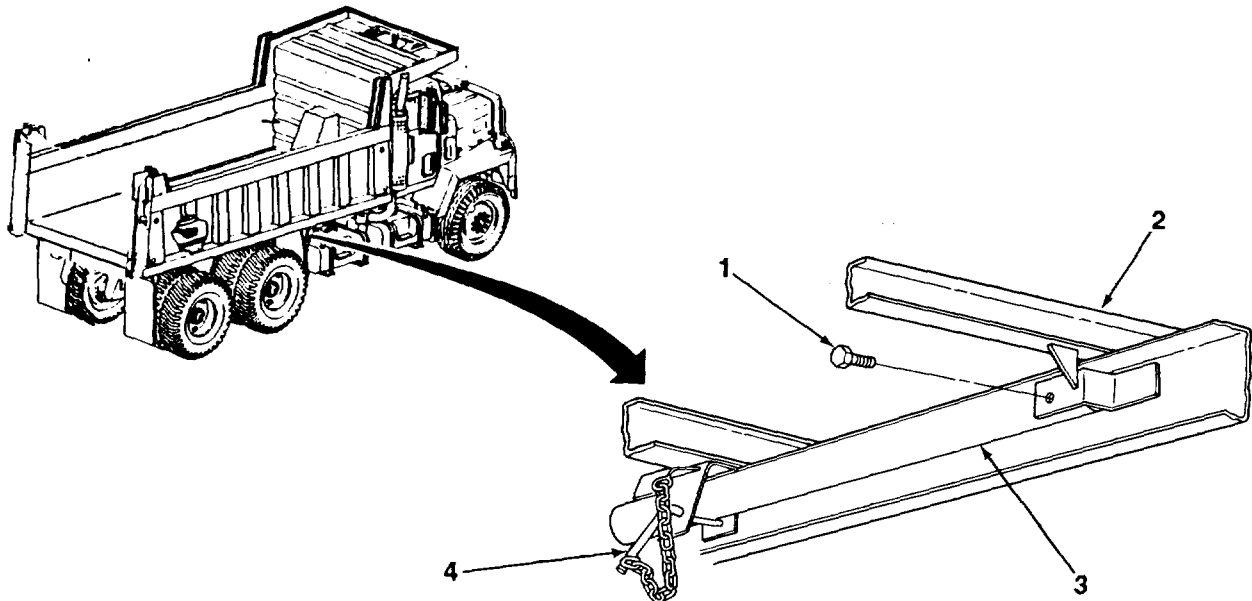

TA704209

15-36. DUMP BODY REPLACEMENT (Con't).**WARNING**

Welding or cutting may produce fumes and gases hazardous to health. Avoid breathing these fumes and gases.

3. Using metal cutting torch, remove two steel plates (7) from dump body (2) to expose each end of cylinder pin (5).
4. Remove cylinder pin (5) from top of hydraulic cylinder (6).

WARNING

Ensure that vehicle is on level ground and that rear wheels are chocked to prevent vehicle from moving. Severe Injury to personnel may result.

5. Using suitable overhead lifting device attached to dump body (2), raise dump body just enough to take weight of dump body off hinge bar (9).
6. Remove two cotter pins (11), spacers (10), and hinge bar (9) to separate dump body (2) from frame (8). Discard cotter pins.

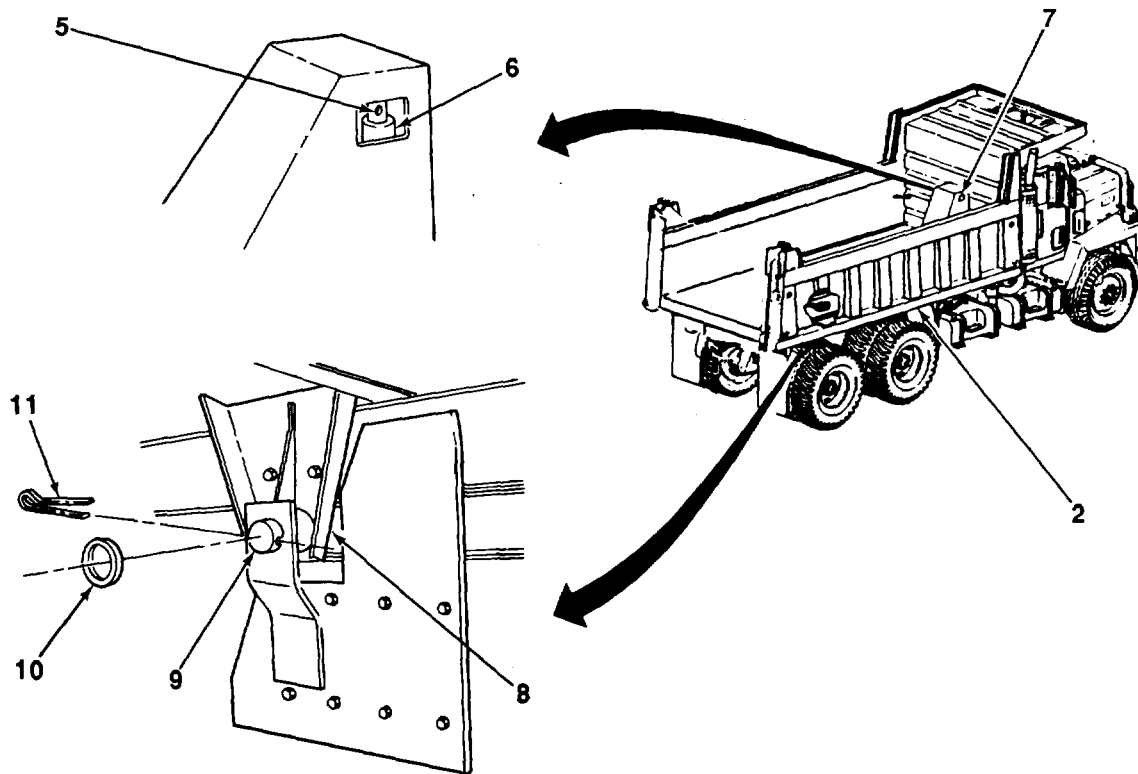

15-36. DUMP BODY REPLACEMENT (Con't).

WARNING

Ensure that all personnel are clear of dump body before raising to prevent injury to personnel.

CAUTION

- As dump body is raised, ensure that all components are free of vehicle to prevent damage to equipment.
- Splashguards and ladder extend downward from dump body. Use care when handling dump body to prevent damage to equipment.

7. Raise dump body (2) vertically to clear top of hydraulic cylinder (6) completely.

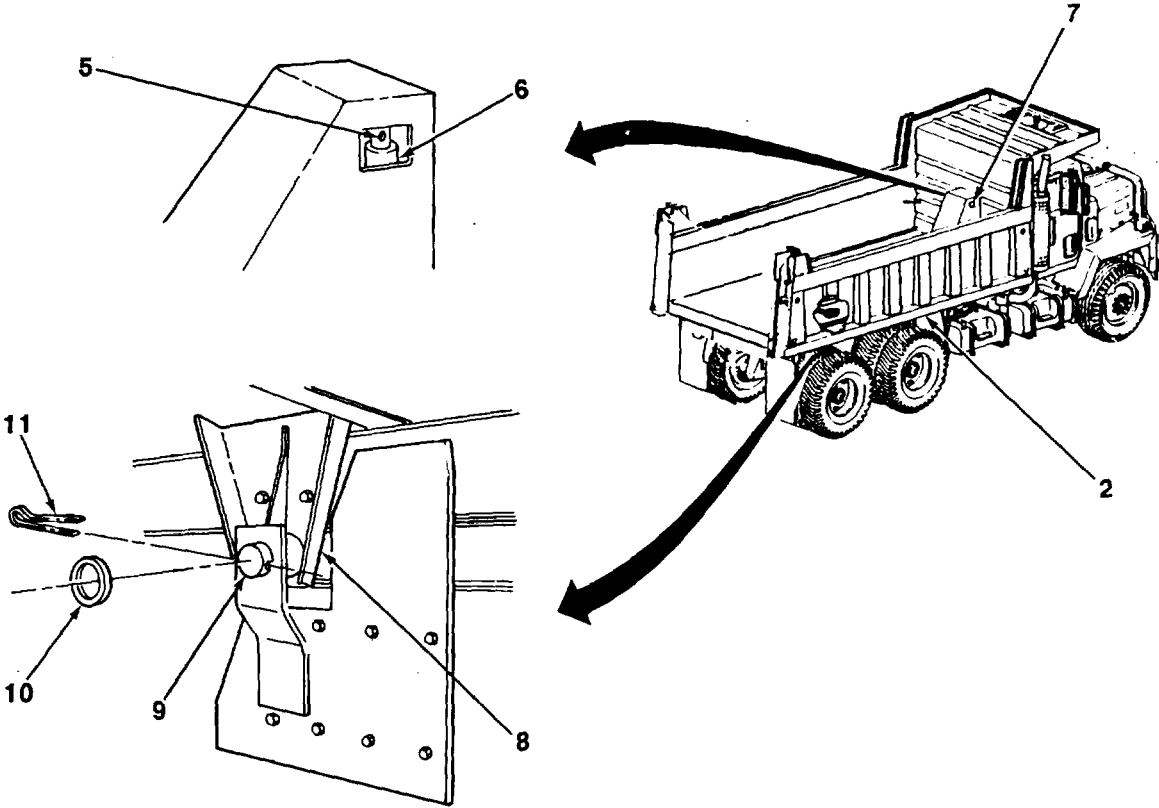

TA704211

15-36. DUMP BODY REPLACEMENT (Con't).

WARNING

Ensure that all personnel are clear of dump body before lowering, to prevent Injury to personnel.

8. Lower dump body to ground.
9. Position wood block between hydraulic cylinder (6) and frame (8) crossmember to prevent hydraulic cylinder from pivoting toward rear of truck.

b. INSTALLATION

1. Remove wood block from between hydraulic cylinder (6) and frame (8) crossmember.

WARNING

Ensure that all personnel are clear of dump body before raising to prevent Injury to personnel.

2. Attach lifting device to dump body (2). Raise dump body vertically high enough to clear hydraulic cylinder (6).
3. Position dump body (2) to frame (8).
4. Install hinge bar (9) and two spacers (10) with two new cotter pins (11).
5. Install cylinder pin (5) to top of hydraulic cylinder (6) to secure hydraulic cylinder to dump body (2).
6. Remove overhead lifting device.

WARNING

Welding or cutting may produce fumes and gases hazardous to health. Avoid breathing these fumes and gases.

7. Using welding torch, weld two steel plates (7) to dump body (2) to cover each end of cylinder pin (5).

15-36. DUMP BODY REPLACEMENT (Con't).**NOTE**

Perform steps 8 and 9 to Install each of two safety props to dump body.

8. Install safety prop (3) on dump body (2) with bolt (1).
9. Secure end of safety prop (3) to dump body (2) with locking lever (4).

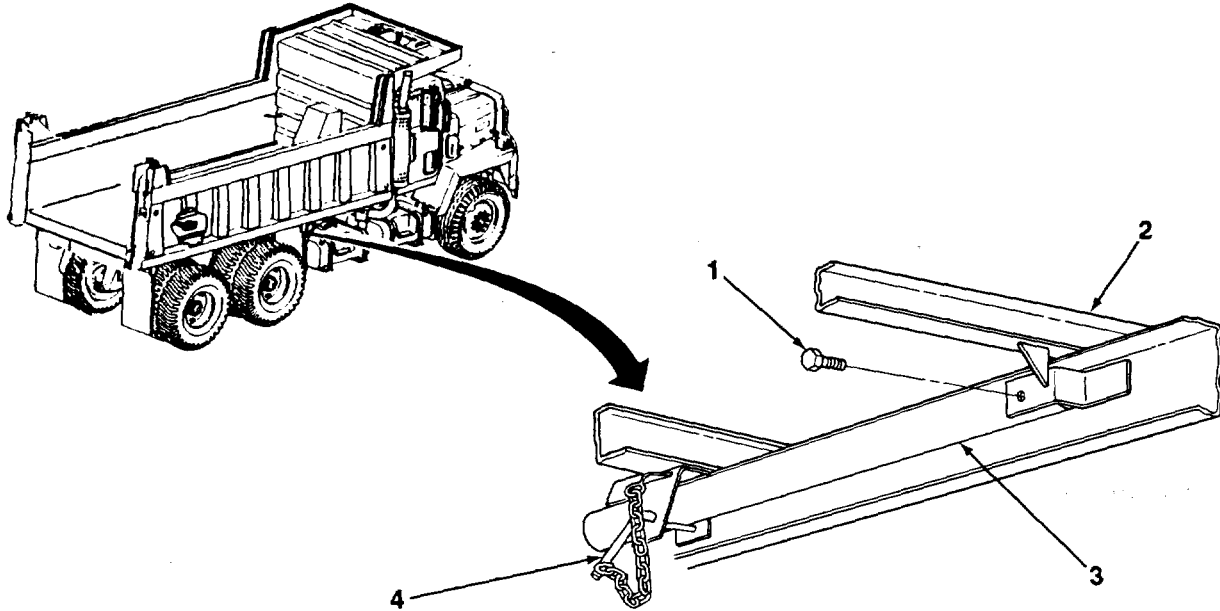
**FOLLOW-ON TASKS:**

- Install body wiring harness (see paragraph 5-6).
- Install pioneer tool rack (see TM 5-3805-254-20).
- Install dump body marker lights (see TM 5-3805-254-20).
- Install tailgate (see paragraph 15-28).
- Install dump body control lever and linkage (see TM 5-3805-254-20).
- Install tailgate release lever and linkage (see paragraph 15-27).

TA704212

CHAPTER 16
POWER TAKE-OFF MAINTENANCE

Paragraph Number	Paragraph Title	Page Number
16-1	Power Take-off Replacement.....	16-1
16-2	Air and Vacuum Shift Maintenance.....	16-5
16-3	Power Take-off Repair	16-8
16-4	Power Take-off Output Shaft Replacement	16-16
16-5	Power Take-off Control Valve Replacement.....	16-18

16-1. POWER TAKE-OFF REPLACEMENT.

This Task Covers:

a. Removal

b. Installation

Initial Setup:

Equipment Conditions:

- Air and vacuum shift removed (see paragraph 16-2).

Tools/Test Equipment:

- General mechanic's tool kit

Materials/Parts:

- One gasket
- One retaining ring
- Five copper washers

a. REMOVAL

1. Mark propeller shaft (1) and universal joint (2) for assembly.
2. Disconnect oil hose (4) from power take-off (3).

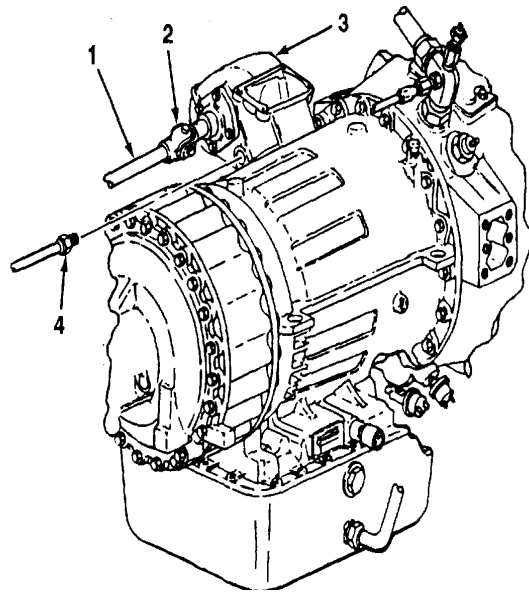

TA704213

16-1. POWER TAKE-OFF REPLACEMENT ((

3. Loosen bolt (7) at top of power take-off (3).
4. Loosen captive capscrew (8) from inside power take-off (3).
5. Remove four nuts (6) and copper washers (5). Discard copper washers.

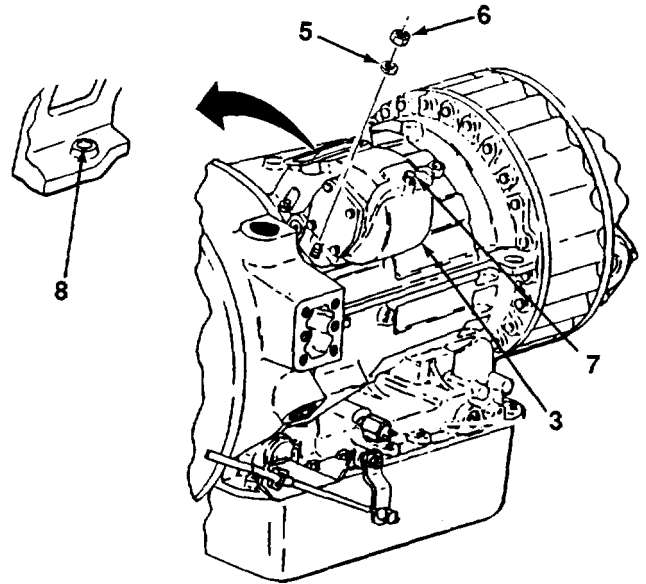

6. Remove power take-off (3), gasket (10), and propeller shaft (1) from top of transmission (9). Discard gasket.

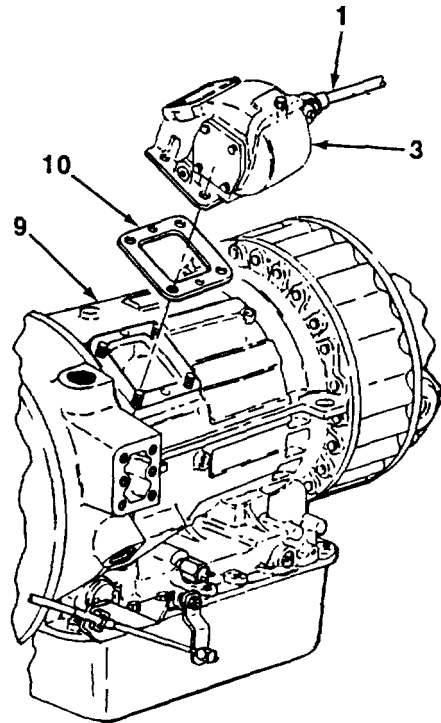

TA704214

TA704214

16-1. POWER TAKE-OFF REPLACEMENT (Con't).

7. Remove bolt (7) and copper washer (12) from power take-off (3). Discard copper washer.
8. Remove retaining ring (11) and captive capscrew (8). Discard retaining ring.
9. Loosen setscrew (15) and remove yoke (14) and propeller shaft (1) from power take-off shaft (16).
10. Remove woodruff key (13) from power take-off shaft (16).

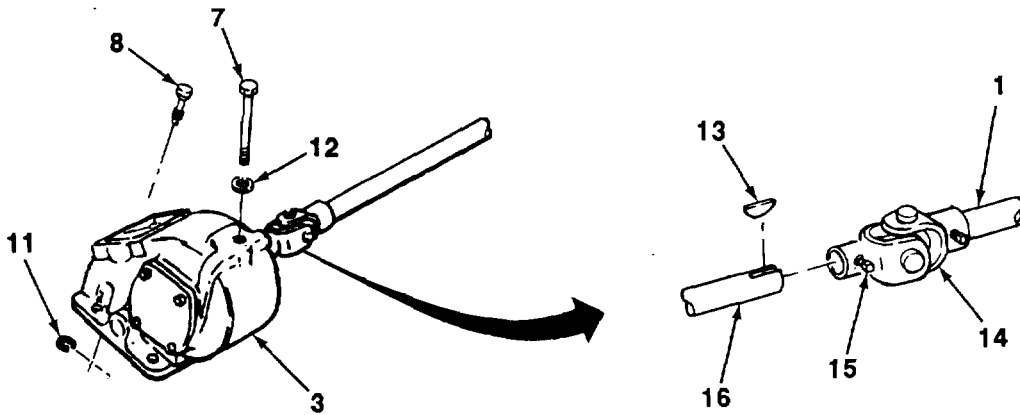
**b. INSTALLATION**

1. Install woodruff key (13) in power take-off shaft (16).
2. Install yoke (14) and propeller shaft (1) to power take-off shaft (16) and tighten setscrew (15).
3. Install captive capscrew (8) to power take-off (3) with new retaining ring (11).
4. Loosely install new copper washer (12) and new bolt (7) to power take-off (3).
5. Install new gasket (10) and power take-off (3) to top of transmission (9).
6. Install four new copper washers (5) and nuts (6). Tighten four nuts (6) and bolt (7).
7. Tighten captive capscrew (8).

TA704215

16-1. POWER TAKE-OFF REPLACEMENT (Con't).

8. Connect oil hose (4) to power take-off (3).

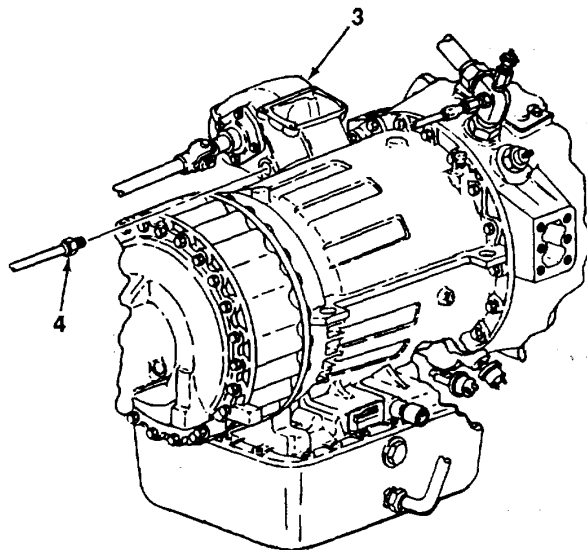
**FOLLOW-ON TASKS:**

- Install air and vacuum shift (see paragraph

TA704216

16-2. AIR AND VACUUM SHIFT MAINTENANCE.

This Task Covers:

- a. Removal
- b. Disassembly
- c. Cleaning and Inspection

- d. Assembly
- e. Installation

Initial Setup:

Equipment Conditions:

- Floorboards and inserts removed (see paragraph 15-3).
- Power take-off light switch removed (see TM 5-3805-254-20).

Materials/Parts:

- Hydraulic fluid (Item 7, Appendix B)
- Dry cleaning solvent (Item 23, Appendix B)
- One gasket
- Three performed packings

General Safety Instructions:

- Dry cleaning solvent is flammable and must not be used near open flame. Use only in a well-ventilated area.

Tools/Test Equipment:

- General mechanic's tool kit
- Field automotive shop set

a. REMOVAL

Remove four screws (1), cover (2), and gasket (3) from power take-off (4). Discard gasket.

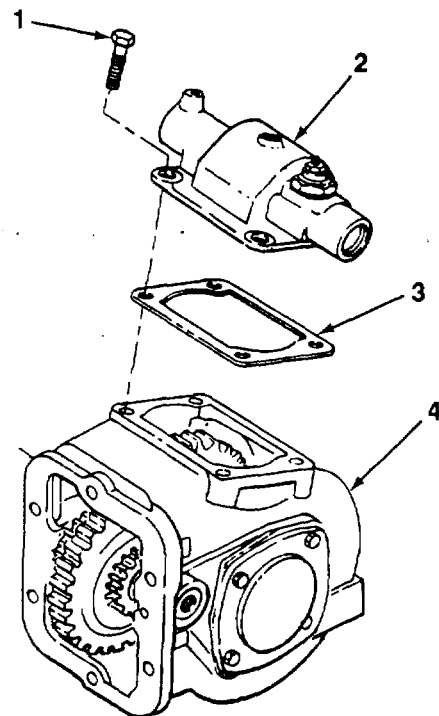

TA704217

16-2. AIR AND VACUUM SHIFT MAINTENANCE (Con't).**b. DISASSEMBLY**

1. Remove plug (5).

WARNING

Piston shaft and access covers are under spring compression. Use care when removing to avoid injury.

2. Remove two retaining rings (7), access covers (8), performed packings (9), and spring (12). Discard performed packings.
3. Remove screw (10) from shifter fork (11).
4. Remove piston shaft (13), performed packing (14), and shifter fork (11) from cover (2). Discard performed packing.
5. Remove guide screw (6).

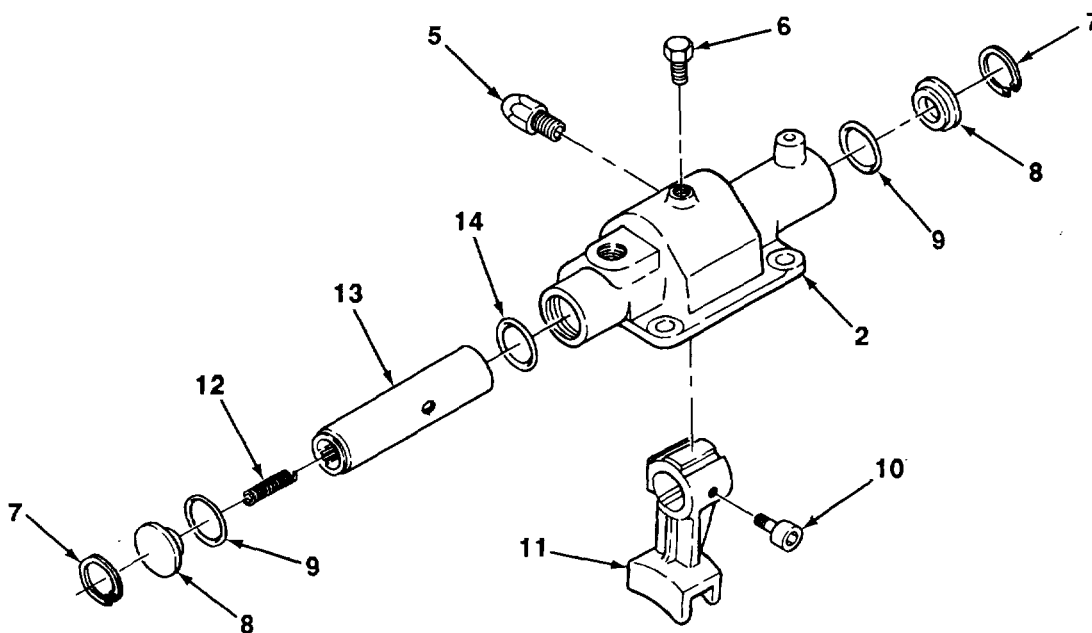
**c. CLEANING AND INSPECTION |****WARNING**

Dry cleaning solvent, P-D-680, is toxic and flammable. Always wear protective goggles and gloves, and use only in a well-ventilated area. Avoid contact with skin, eyes, and clothes, and DO NOT breathe vapors. DO NOT use near open flame or excessive heat. The solvent's flash point is 100°F-138°F (38°C-59°C). If you become dizzy while using cleaning solvent, immediately get fresh air and medical help. If solvent contacts eyes, immediately wash your eyes and get medical aid.

1. Clean metal parts with dry cleaning solvent.

TA704218

16-2. AIR AND VACUUM SHIFT MAINTENANCE (Con't).

2. Inspect metal parts for cracks, breaks, wear, and other damage. Replace if damaged.
3. Inspect for broken or deformed spring. Replace spring if broken or deformed.
4. Apply thin coat of hydraulic fluid to surfaces of new preformed packings and internal metal parts.

d. ASSEMBLY

1. Install guide screw (6) in cover (2).
2. Install new preformed packing (14), shifter fork (11), and piston shaft (13) in cover (2). Aline hole in side of piston shaft with threaded hole in shifter fork.
3. Install screw (10) in shifter fork (11).
4. Install spring (12), two new preformed packings (9), access covers (8), and retaining rings (7).
5. Install plug (5).

e. INSTALLATION

Install new gasket (3) and cover (2) on power take-off (4) with four screws (1).

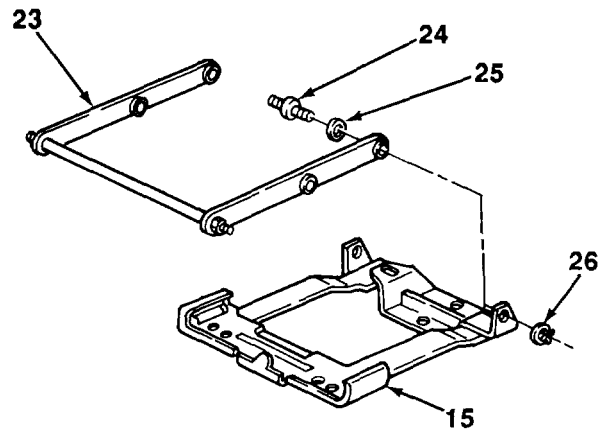
**FOLLOW-ON TASKS:**

- Install power take-off light switch (see TM 5-3805-254-20).
- Install floorboards and inserts (see paragraph 15-3).

TA704219

16-3. POWER TAKE-OFF REPAIR.*This Task Covers:*

- a. Disassembly
- b. Cleaning and Inspection

- c. Assembly

*Initial Setup:***Equipment Conditions:**

* Power take-off removed (see paragraph 16-1).

Tools/Test Equipment:

- General mechanic's tool kit

References:

- TM 9-214

Materials/Parts:

- Hydraulic fluid (Item 7, Appendix B)
- Dry cleaning solvent (Item 23, Appendix B)
- One oil seal
- One repair kit
- Field automotive shop set* Two gaskets

General Safety Instructions:

- Dry cleaning solvent is flammable and must not be used near open flame. Use only in a well-ventilated area.

a. DISASSEMBLY

1. Remove retaining ring (1) and screw (3) from housing (2).
2. Remove setscrew (4) from housing (2).

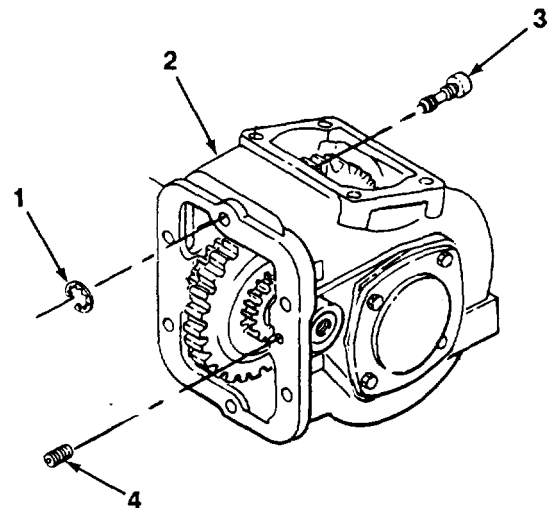

16-3. POWER TAKE-OFF REPAIR (Con't).

- 3. Remove shaft (6) and plug (7) from housing (2). Discard shaft and plug.
- 4. Remove washer (5), spur gear (9), and slotted washer (8) from housing (2).

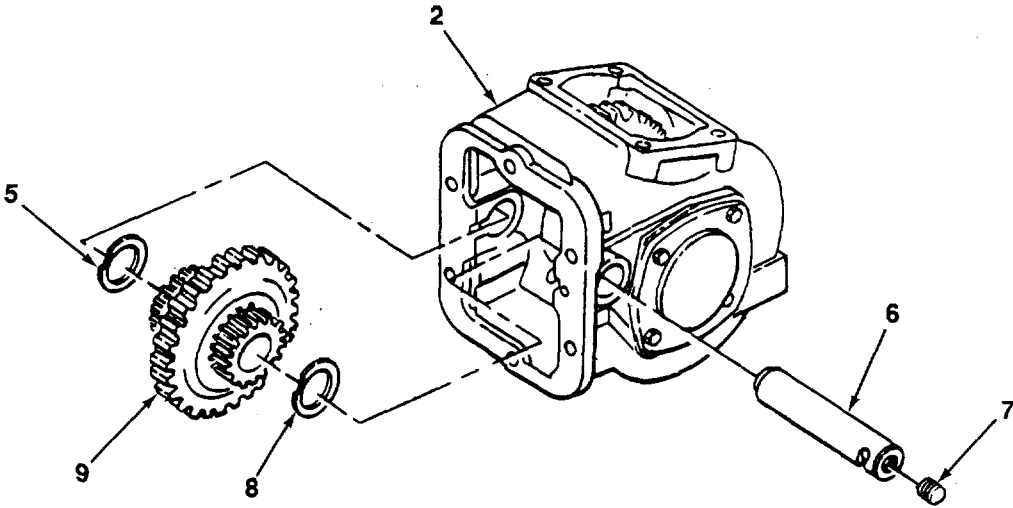

- 5. Remove input gear (10) from spur gear (9).
- 6. Remove two roller assemblies (12) and sleeve spacer (11) from input gear (10).

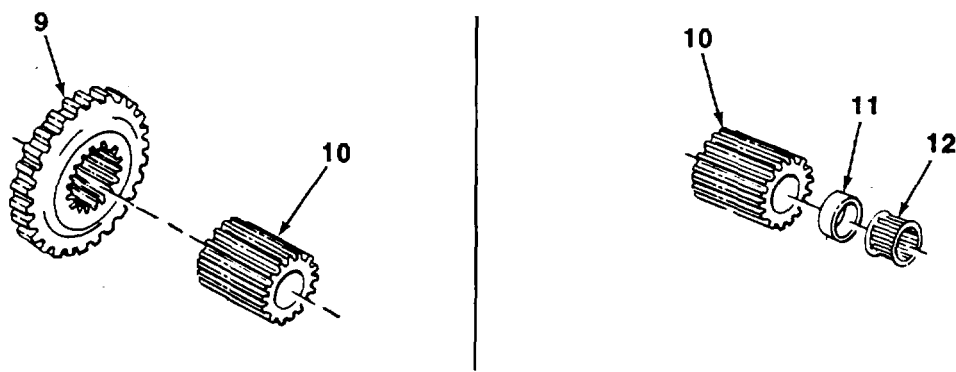

16-3. POWER TAKE-OFF REPAIR (Con't).

- 7. Mark bearing cap (15) and housing (2) to aid in assembly.
- 8. Remove four bolts (16), bearing cap (15), and gasket (13). Discard gasket.
- 9. Using puller, remove roller cup (14) from bearing cap (15).

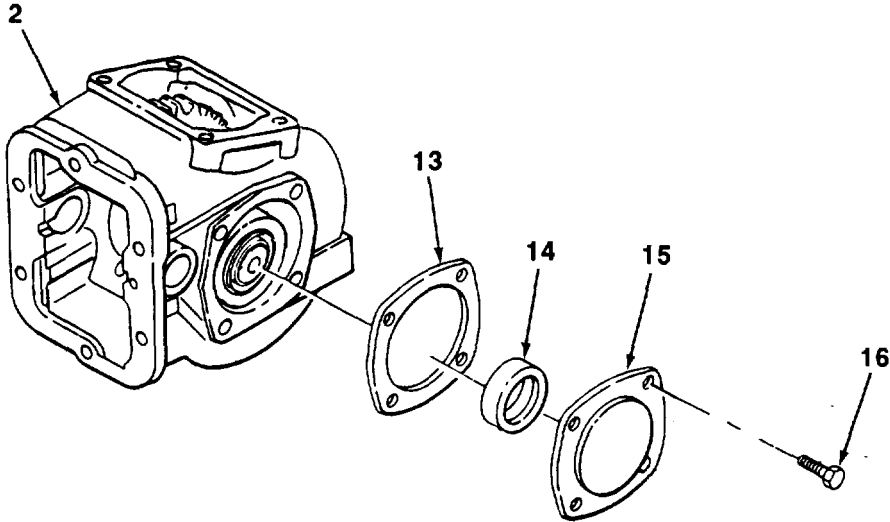

- 10. Using puller, remove cone (20) from shaft (17).
- 11. Remove retaining ring (19) and sleeve spacer (18) from shaft (17).

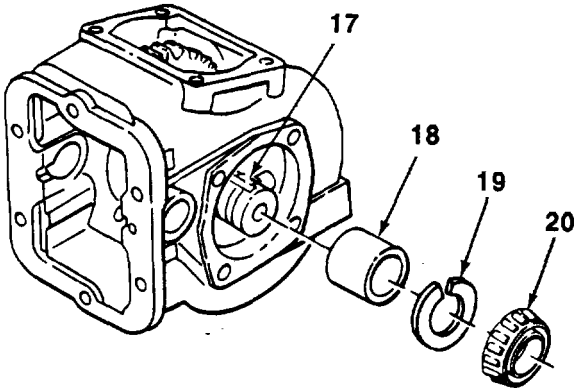

16-3. POWER TAKE-OFF REPAIR (Con't).

12. Mark cap (22) and housing (2) to aid in assembly.

NOTE

Spur gear is removed through side of housing as shaft is removed through front end of housing.

13. Remove four bolts (21), cap (22), gasket (23), shaft (17), and spur gear (24) from housing (2). Discard gasket.

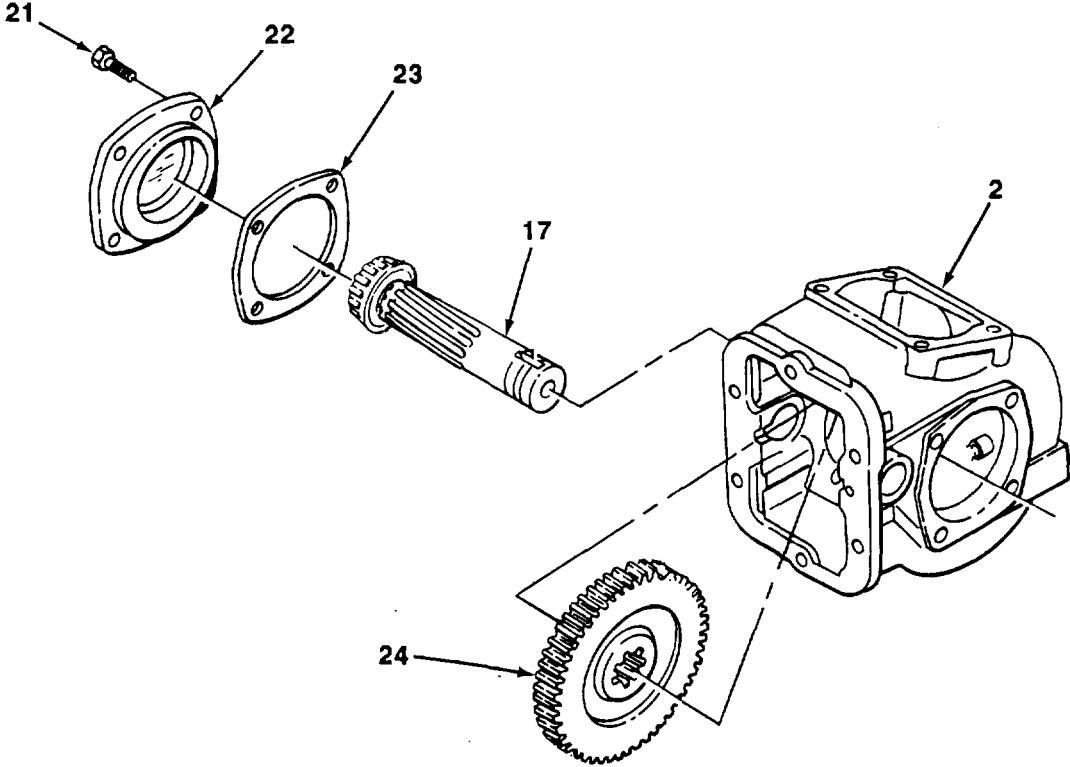

- 14. Press oil seal (25) from cap (22). Discard oil seal.
- 15. Using puller, remove roller cup (26) from cap (22).

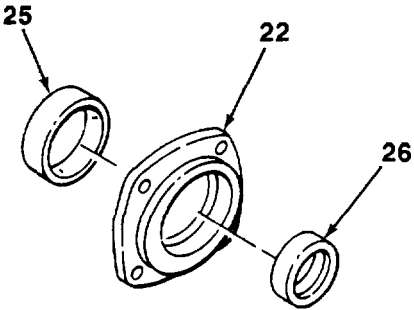

16-3. POWER TAKE-OFF REPAIR (Con't).

16. Press cone (27) off shaft (17).

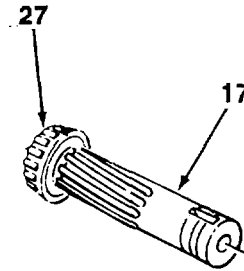
**b. CLEANING AND INSPECTION****WARNING**

Dry cleaning solvent, P-D-680, is toxic and flammable. Always wear protective goggles and gloves, and use only in a well-ventilated area. Avoid contact with skin, eyes, and clothes, and DO NOT breathe vapors. DO NOT use near open flame or excessive heat. The solvent's flash point is 100°F-138°F (38°C-59°C). If you become dizzy while using cleaning solvent, immediately get fresh air and medical help. If solvent contacts eyes, immediately wash your eyes and get medical aid.

1. Clean metal parts with dry cleaning solvent.
2. Inspect metal parts for cracks, breaks, wear, and other damage. Replace if damaged.
3. Inspect gears for chipped, worn, or broken teeth. Replace if damaged.
4. Inspect shaft splines for chipped, worn, or broken splines. Replace if damaged.
5. Inspect cones and roller assemblies for wear or damage (see TM 9-214). Replace if damaged.
6. Apply thin coat of hydraulic fluid to all internal metal parts.

c. ASSEMBLY

1. Press cone (27) on shaft (17).
2. Press roller cup (26) into cap (22).
3. Press new oil seal (25) into cap (22).

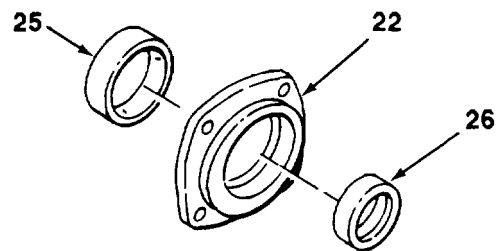

TA704224

16-3. POWER TAKE-OFF REPAIR (Con't).

NOTE

Spur gear is installed through side of housing as shaft is installed through front end of housing.

- 4. Install spur gear (24), shaft (17), new gasket (23), and cap (22) on housing (2) with four bolts (21).

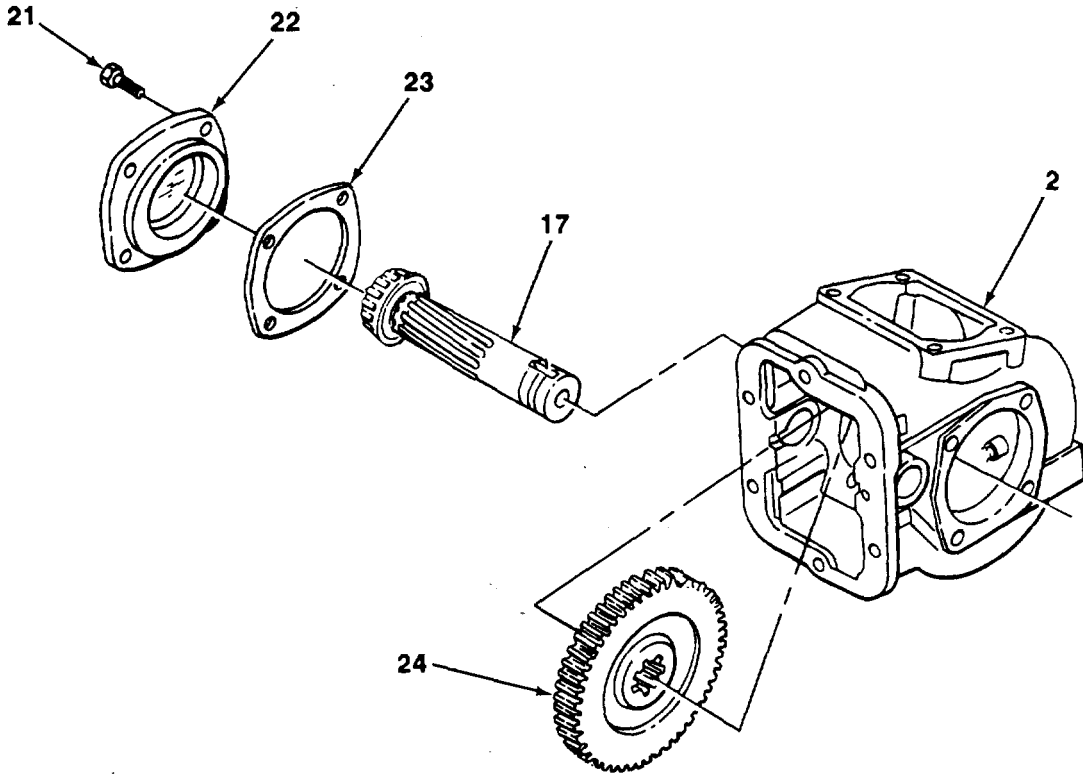

- 5. Install sleeve spacer (18) and retaining ring (19) on shaft (17).
- 6. Press cone (20) on shaft (17).

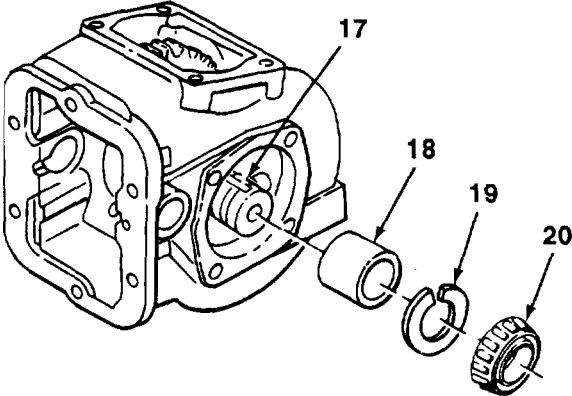

16-3. POWER TAKE-OFF REPAIR (Con't).

- 7. Press roller cup (14) into bearing cap (15).
- 8. Install new gasket (13) and bearing cap (15) on housing (2) with four bolts (16).

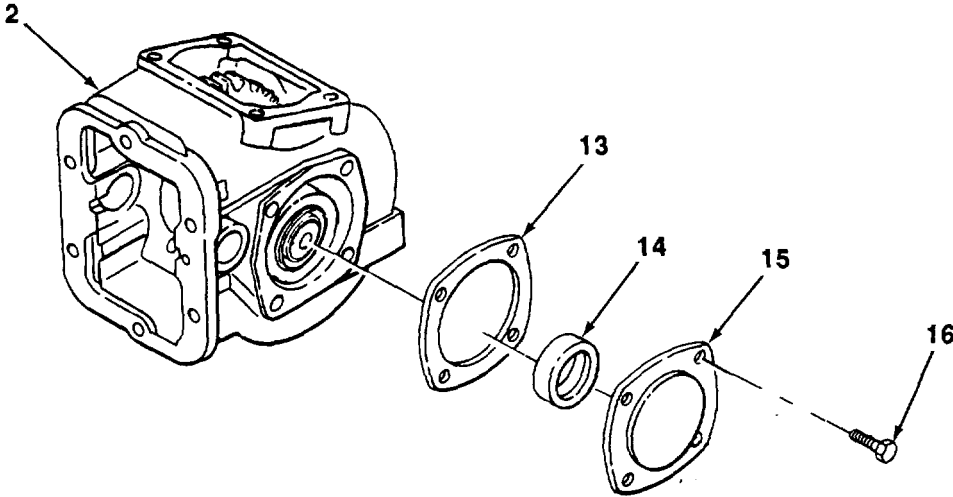

- 9. Install two roller assemblies (12) and sleeve spacer (11) in input gear (10).
- 10. Install spur gear (9) over INPUT GEAR (10).

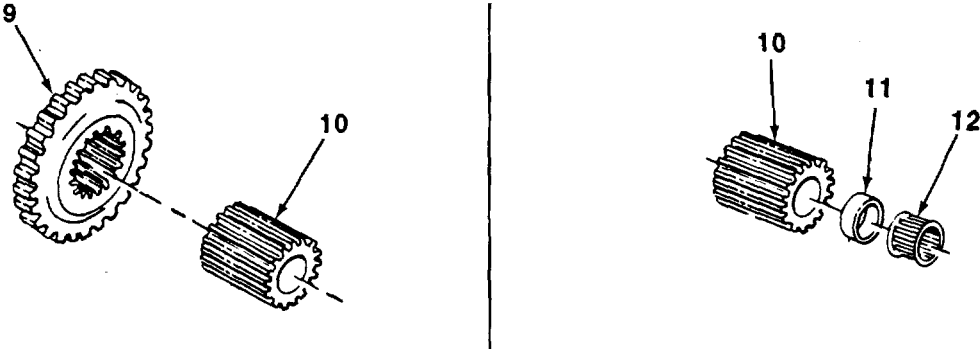

16-3. POWER TAKE-OFF REPAIR (Con't).

11. Install new plug (7) in end of new shaft (6).

NOTE

Ensure that hole inside of shaft aligns with threaded hole in housing.

12. Install slotted washer (8), spur gear (9), washer (5), and shaft (6) in housing (2).

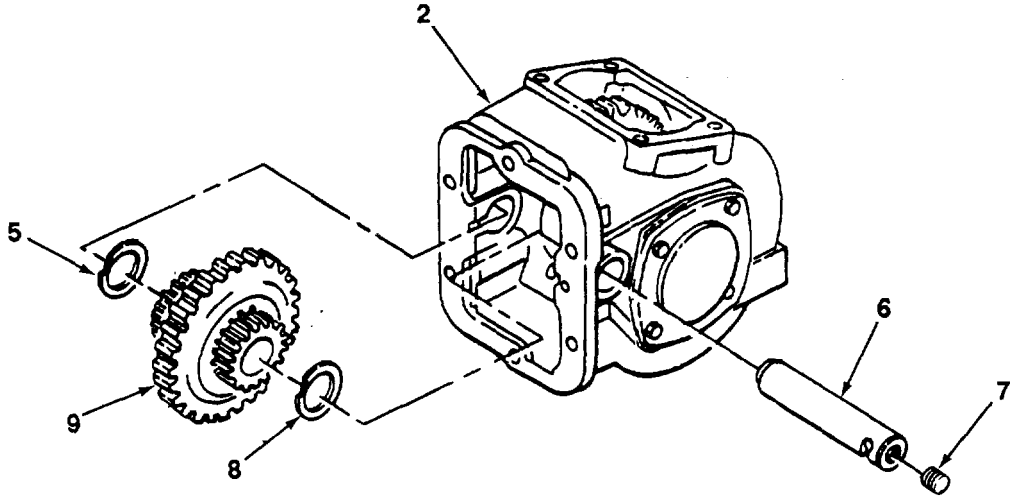

13. Install setscrew (4) in housing (2).

14. Install screw (3) and retaining ring (1) in housing (2).

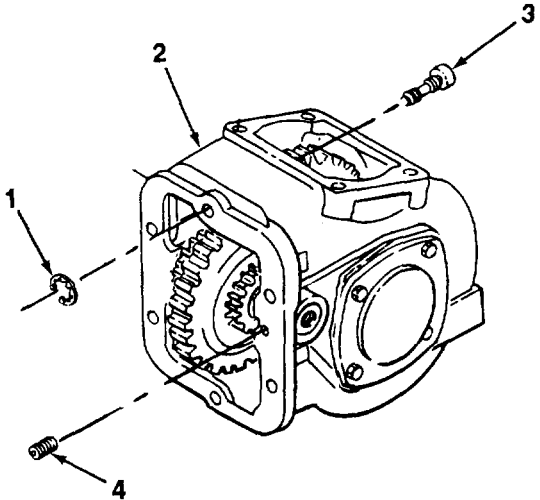

FOLLOW-ON TASKS:

- Install power take-off (see paragraph 16-1).

16-4. POWER TAKE-OFF OUTPUT SHAFT REPLACEMENT.

This Task Covers:

- a. Removal
- b. Installation

Initial Setup:

Equipment Conditions:

- Floorboards and inserts removed (see paragraph 15-3).

Tools/Test Equipment:

- General mechanic's tool kit

Materials/Parts:

- Grease (Item 10, Appendix B)

a. REMOVAL

1. Mark power take-off output shaft (6) and universal joint (5) to aid in assembly.
2. Remove setscrew (4) from universal joint at take-off output shaft (6)

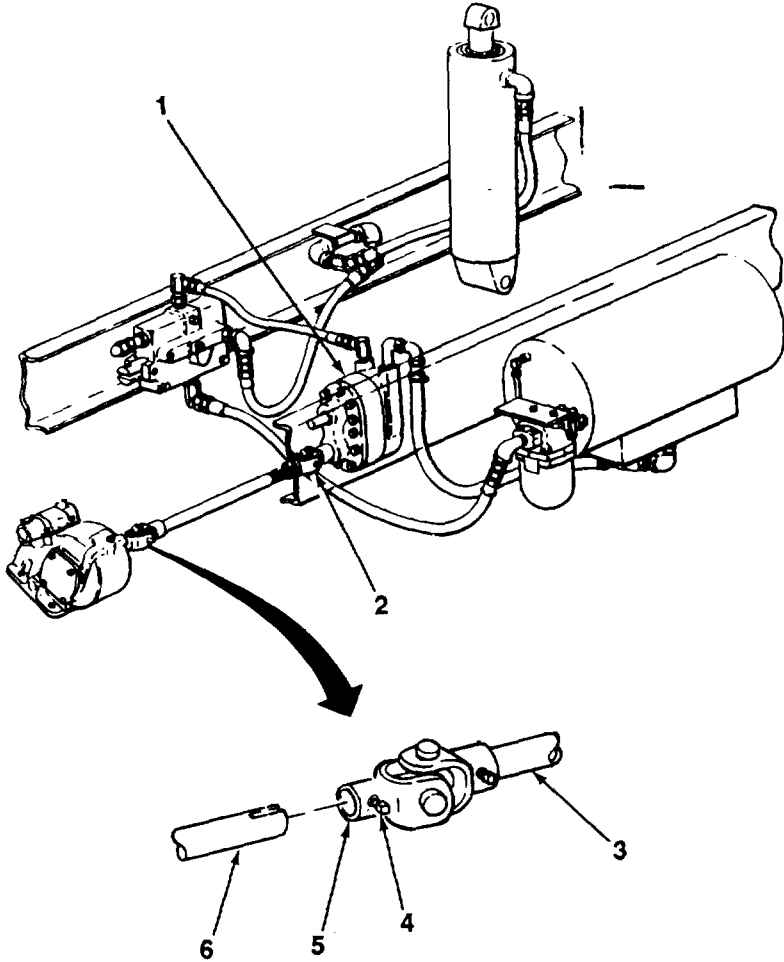

16-4. POWER TAKE-OFF OUTPUT SHAFT REPLACEMENT (Con't).

3. Disconnect universal joint (5) from power take-off output shaft (6).
4. Remove other setscrew (4) and universal joint (2) with shaft (3) from hydraulic pump (1).

b. INSTALLATION

1. Install universal joint (2) with shaft (3) to hydraulic pump (1) and install setscrew (4).
2. Apply thin coat of grease to splines of shaft (3).
3. Install universal joint (5) on power take-off output shaft (6) as marked.
4. Install other setscrew (4).

FOLLOW-ON TASKS:

- Install floorboards and inserts (see paragraph 15-3).

16-5. POWER TAKE-OFF CONTROL VALVE REPLACEMENT.*This Task Covers:*

a. Removal

b. Installation

*Initial Setup:***Equipment Conditions:**

* Power take-off indicator lamp removed (see TM 5-3805-254-20).

Tools/Test Equipment:

• General mechanic's tool kit

Materials/Parts:

• Two lockwashers

a. REMOVAL

1. Disconnect air line (4) from adapter (3).
2. Disconnect air line (1) from elbow (2).

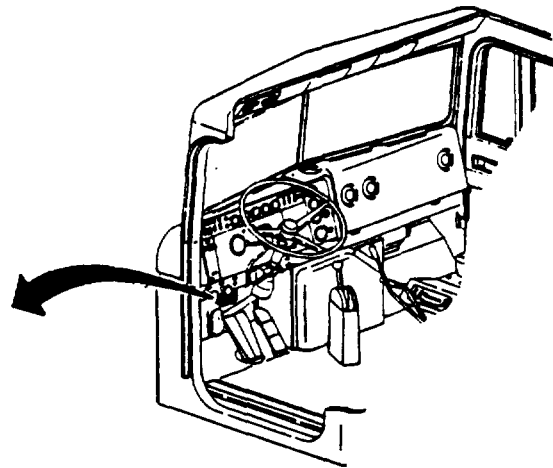
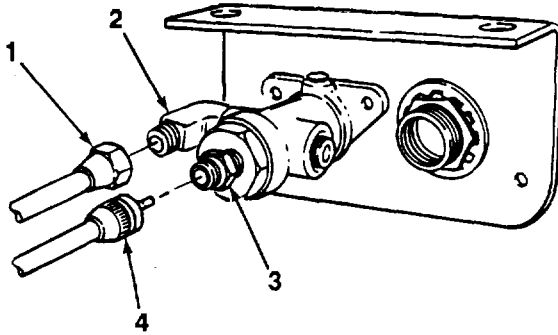

3. Remove two nuts (10), lockwashers (11), washers (12), screws (6), and bracket (8) from dash panel (7). Discard lockwashers.
4. Remove two screws (9) and control valve (5) from bracket (8).
5. Remove adapter (3) from control valve (5).
6. Remove elbow (2) from control valve (5).
7. Remove plug (13) from control valve (5).

TA704229

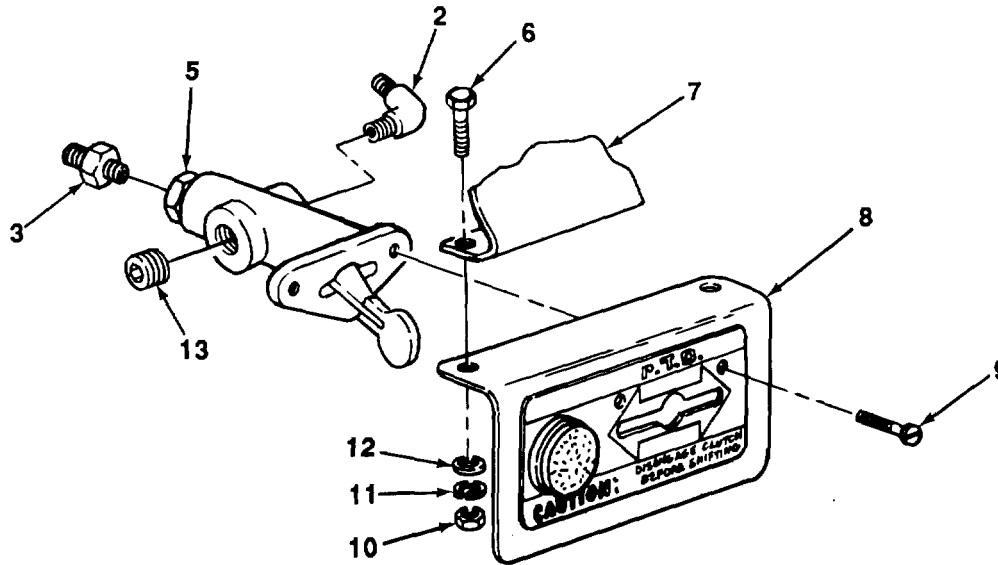
16-5. POWER TAKE-OFF CONTROL VALVE REPLACEMENT (Con't).**b. INSTALLATION**

1. Install plug (13) to control valve (5).
2. Install elbow (2) to side of control valve (5).
3. Install adapter (3) to control valve (5).
4. Install control valve (5) on bracket (8) with two screws (9).
5. Install bracket (8) on dash panel (7) with two screws (6), washers (12), new lockwashers (11), and nuts (10).
6. Connect air line (1) to elbow (2).
7. Connect air line (4) to adapter (3).

FOLLOW-ON TASKS:

* Install power take-off Indicator lamp (see TM 5-3805-254-20).

TA704230

16-19/(16-20 Blank)

**CHAPTER 17
HYDRAULIC SYSTEM MAINTENANCE**

Paragraph Number	Paragraph Title	Page Number
17-1	Dump Body Hydraulic Lift Cylinder Replacement.....	17-1
17-2	Hydraulic Rotary Pump Maintenance.....	17-4
17-3	Hydraulic Pump Control Valve Maintenance.....	17-11
17-4	Hydraulic Oil Reservoir Replacement	17-17

17-1. DUMP BODY HYDRAULIC LIFT CYLINDER REPLACEMENT.

This Task Covers:

- | | |
|------------|-----------------|
| a. Removal | b. Installation |
|------------|-----------------|
-

Initial Setup:

Equipment Conditions:

- Dump body removed (see paragraph 15-36).
- Valve-to-cylinder pressure hose and fitting disconnected - (see TM 5-3805-254-20).

Tools/Test Equipment:

- General mechanic's tool kit
- Field automotive shop set
- Welding shop set
- Welding tool kit

Materials/Parts:

- Grease (Item 10, Appendix B)
- Two cotter pins

Personnel Required: Two



17-1. DUMP BODY HYDRAULIC LIFT CYLINDER REPLACEMENT (Con't).

a. REMOVAL

1. Attach overhead lifting device to hydraulic cylinder (1).
2. Raise hydraulic cylinder (1) just enough to take weight of hydraulic cylinder off cylinder base pin (4).

WARNING

Ensure that all personnel are clear of hydraulic cylinder before raising to prevent injury to personnel.

3. Remove two cotter pins (3) and cylinder base pin (4) to separate hydraulic cylinder (1) from subframe (5). Discard cotter pins.
4. Raise hydraulic cylinder (1) to clear subframe (5).
5. Move hydraulic cylinder (1) to safe work area and place on secure supports. Remove overhead lifting device.

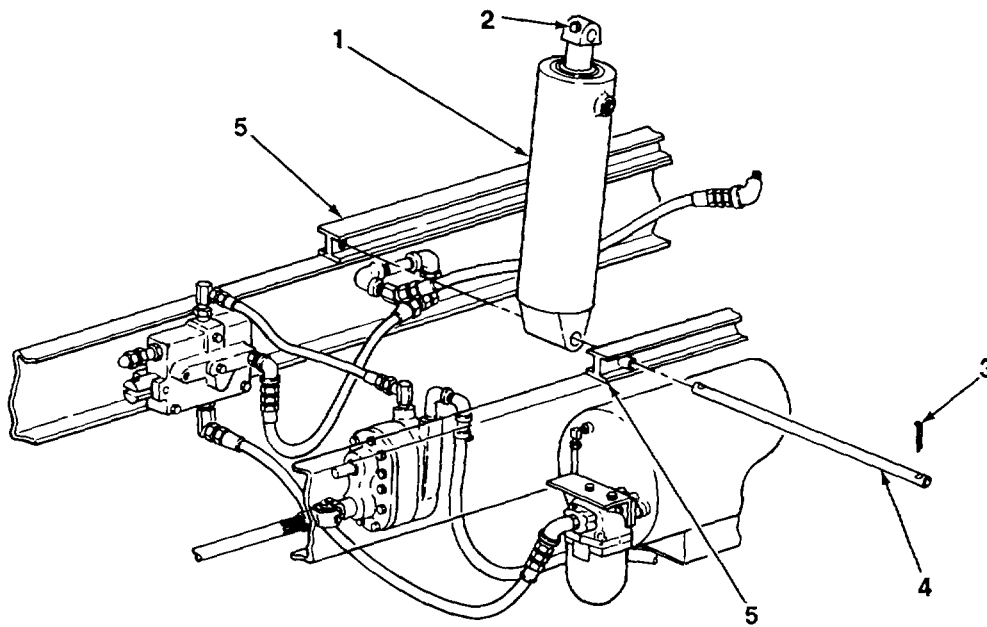

17-1. DUMP BODY HYDRAULIC LIFT CYLINDER REPLACEMENT (Con't).

b. INSTALLATION

1. Attach overhead lifting device to hydraulic cylinder (1).

WARNING

Ensure that all personnel are clear of hydraulic cylinder before raising to prevent Injury to personnel.

2. Raise hydraulic cylinder (1) and move to vehicle.
3. Position lower end of hydraulic cylinder (1) to subframe (5).
4. Apply coat of grease to cylinder base pin (4).
5. Install cylinder base pin (4) and two new cotter pins (3) to secure hydraulic cylinder (1) to subframe (5).
6. Rotate top of hydraulic cylinder (1), if necessary, so that screw (2) faces front of vehicle.
7. Position top of hydraulic cylinder (1) against rear of vehicle cab and remove overhead lifting device.

FOLLOW-ON TASKS:

- Connect valve-to-cylinder pressure hose and fitting (see TM 5-3805-254-20).
- Install dump body (see paragraph 15-36).

17-2. HYDRAULIC ROTARY PUMP MAINTENANCE.

This Task Covers:

- | | |
|----------------------------|-----------------|
| a. Removal | d. Assembly |
| b. Disassembly | e. Installation |
| c. Cleaning and Inspection | |
-

*INITIAL SETUP:***Equipment Conditions: Materials/Parts:**

- Pump-to-valve pressure hose and fittings disconnected (see TM 5-3805-254-20).
- Reservoir-to-pump suction hose and fittings disconnected (see TM 5-3805-254-20).
- Power take-off output shaft removed (see paragraph 16-4).
- Lubricating oil (Item 14, Appendix B)
- Dry cleaning solvent (Item 23, Appendix B)
- Two gaskets

graph 16-4).

graph 16-4).

Tools/Test Equipment:

- General mechanic's tool kit

References:

- TM 9-214
-

General Safety Instructions:

- Dry cleaning solvent is flammable and must not be used near open flame. Use only in a well-ventilated area.

a. REMOVAL

1. Remove two bolts (5) holding hydraulic pump (1) to subframe bracket (2).
2. Remove bolt (3), hydraulic pump (1), and spacer (4) from subframe bracket (2).
3. Remove woodruff key (7) from gearshaft (6).

17-2. HYDRAULIC ROTARY PUMP MAINTENANCE (Con't).

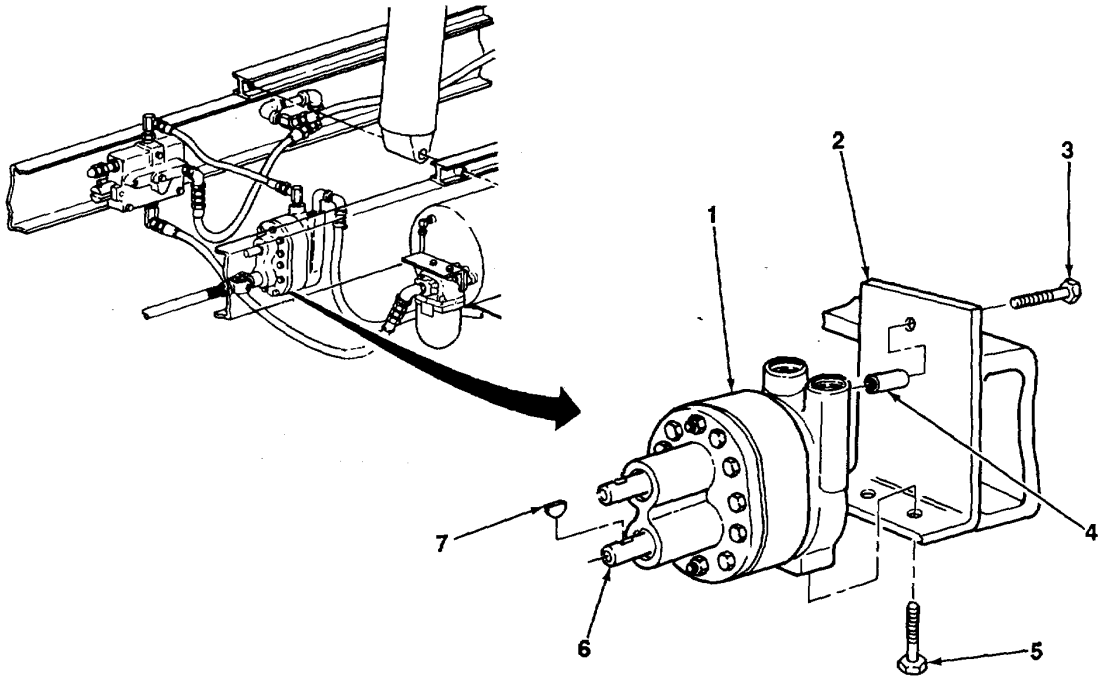

b. DISASSEMBLY

- 1. Remove nut (8) from each end of two studs (9) and remove two studs from hydraulic pump (1).
- 2. Remove ten bolts (10).

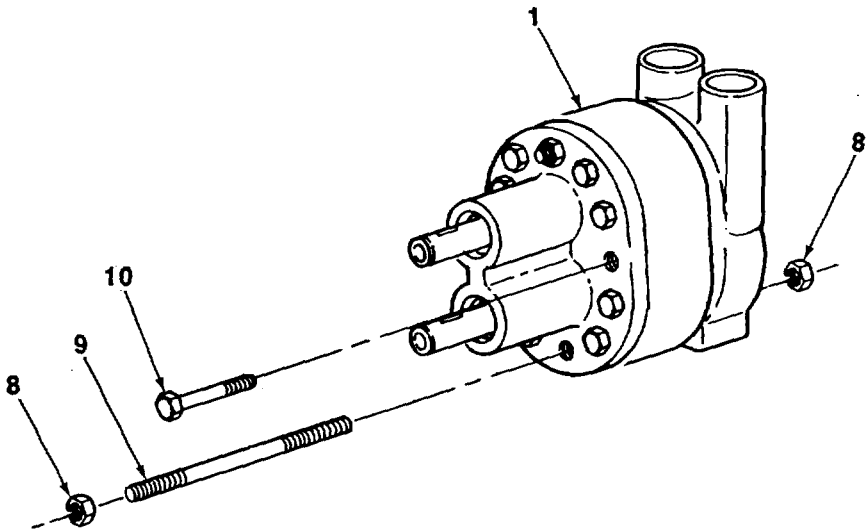

17-2. HYDRAULIC ROTARY PUMP MAINTENANCE (Con't).

3. Separate front housing (11) from housing (14) as an assembly and remove two gearshafts (6), bearing plate (12), and two gaskets (13). Discard gaskets.

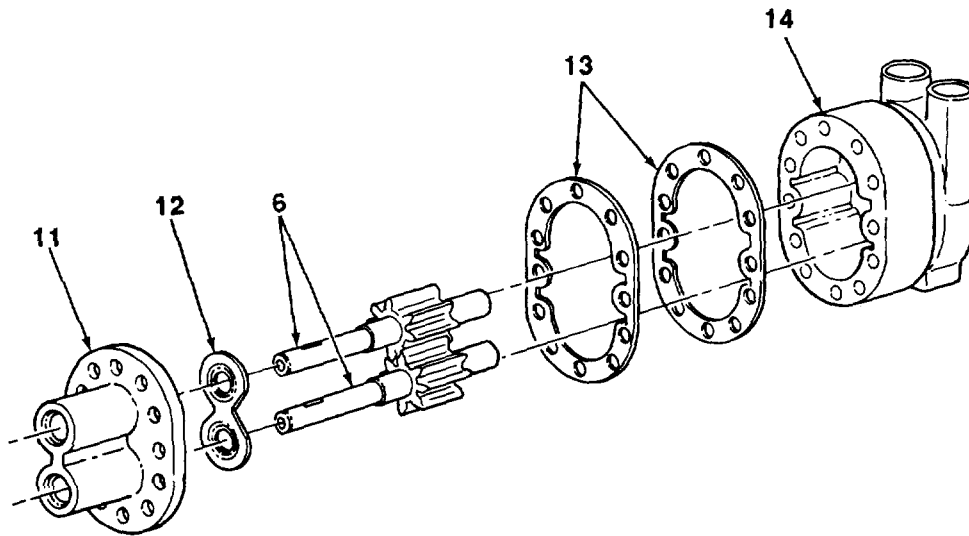

NOTE

Perform step 4 for each of two gearshaft bores.

4. Remove snapping (15), bushing (16), five seals (17), spring (18), and washer (19) from front housing (11).
5. Remove two needle bearings (20) from front housing (11).

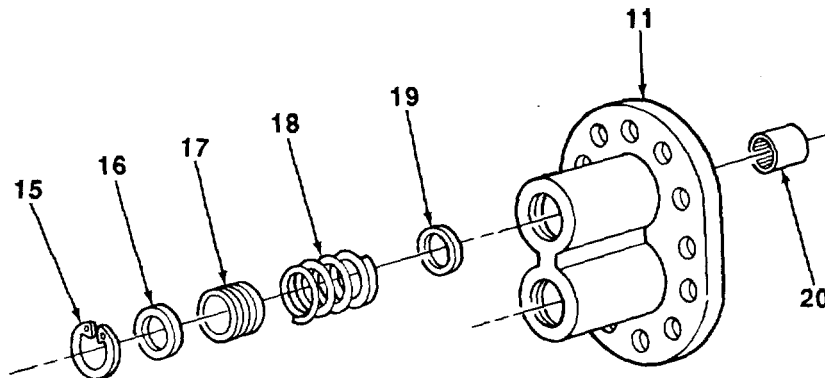

TA704233

17-2. HYDRAULIC ROTARY PUMP MAINTENANCE (Con't).

6. Separate housing (14) and bearing plate (21) from pump body (23).
7. Remove two needle bearings (22) from pump body (23).

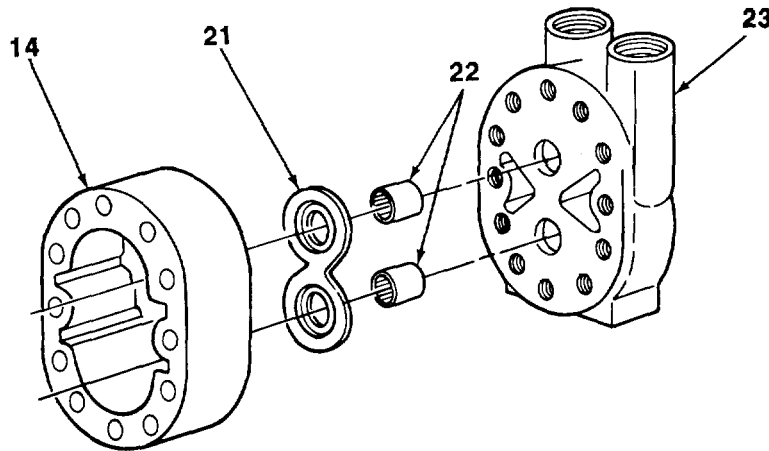
**c. CLEANING AND INSPECTION****WARNING**

Dry cleaning solvent, P-D-680, is toxic and flammable. Always wear protective goggles and gloves, and use only in a well-ventilated area. Avoid contact with skin, eyes, and clothes, and DO NOT breathe vapors. DO NOT use near open flame or excessive heat. The solvent's flash point is 100°F-138°F (38°C-59°C). If you become dizzy while using cleaning solvent, immediately get fresh air and medical help. If solvent contacts eyes, immediately wash your eyes and get medical aid.

1. Clean metal parts with dry cleaning solvent.
2. Inspect metal parts for cracks, breaks, wear, and other damage. Replace if damaged.
3. Inspect gearshafts for damaged or broken teeth. Replace if damaged.
4. Inspect bearings (see TM 9-214). Replace if damaged.
5. Apply thin coat of lubricating oil to all internal metal parts.

TA704234

17-2. HYDRAULIC ROTARY PUMP MAINTENANCE (Con't).

d. ASSEMBLY

- 1. Install two needle bearings (22) in pump body (23).
- 2. Position bearing plate (21) and housing (14) to pump body (23).

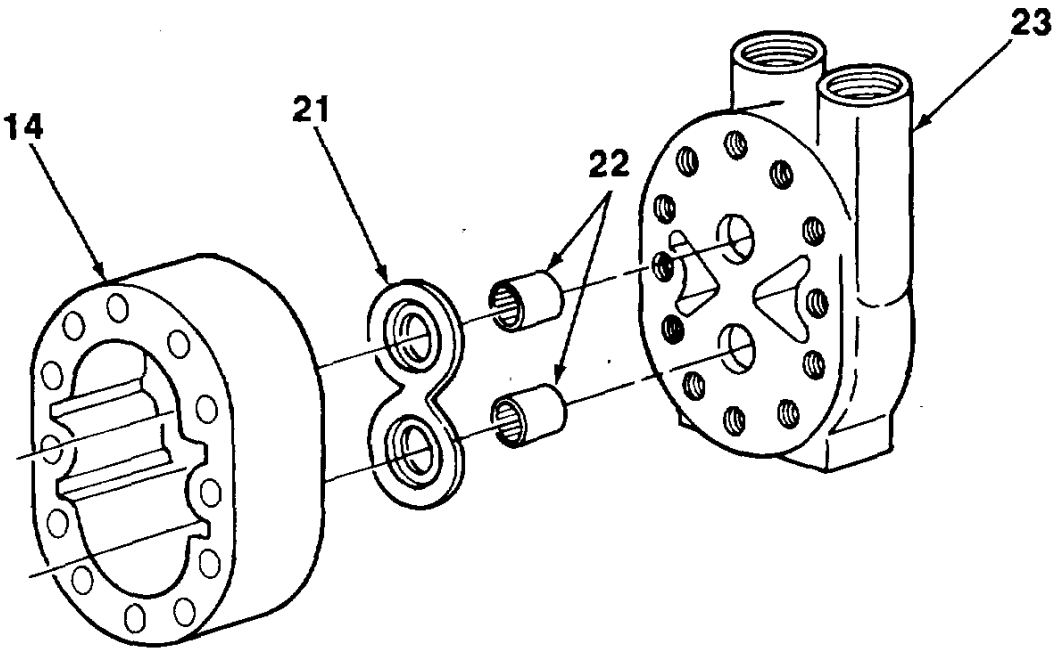

- 3. Install two needle bearings (20) in front housing (11).

NOTE
Perform step 4 for each of two gearshaft bores.

- 4. Install washer (19), spring (18), five seals (17), bushing (16), and snapping (15) in front housing (11).

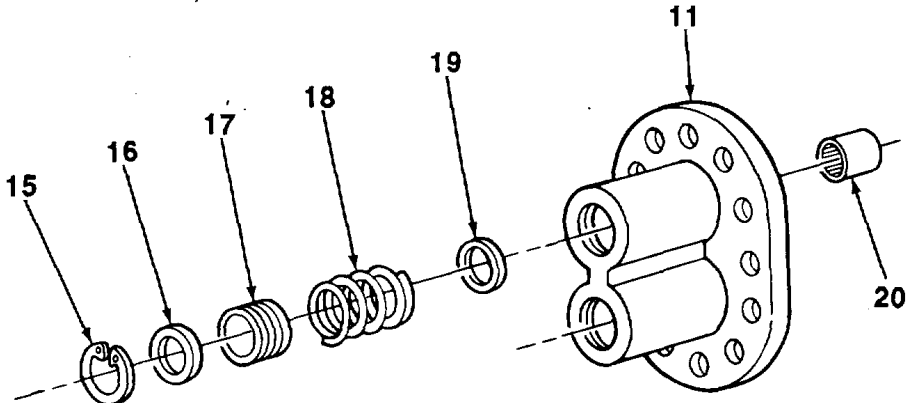

17-2. HYDRAULIC ROTARY PUMP MAINTENANCE (Con't).

- 5. Position two new gaskets (13), bearing plate (12), two gearshafts (6), and front housing (11) to housing (14).

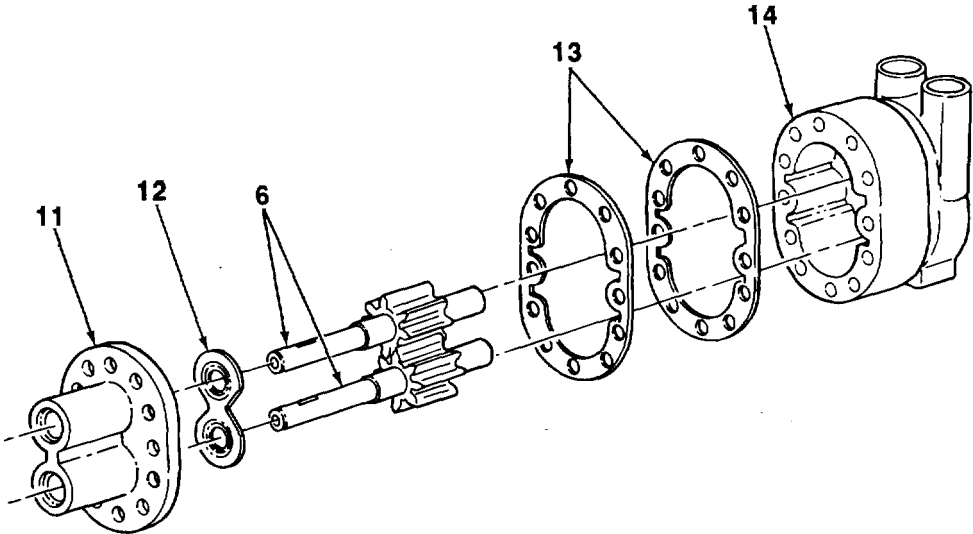

- 6. Install ten bolts (10) to hydraulic pump (1).
- 7. Install two studs (9) and install nut (8) to each end of two studs.

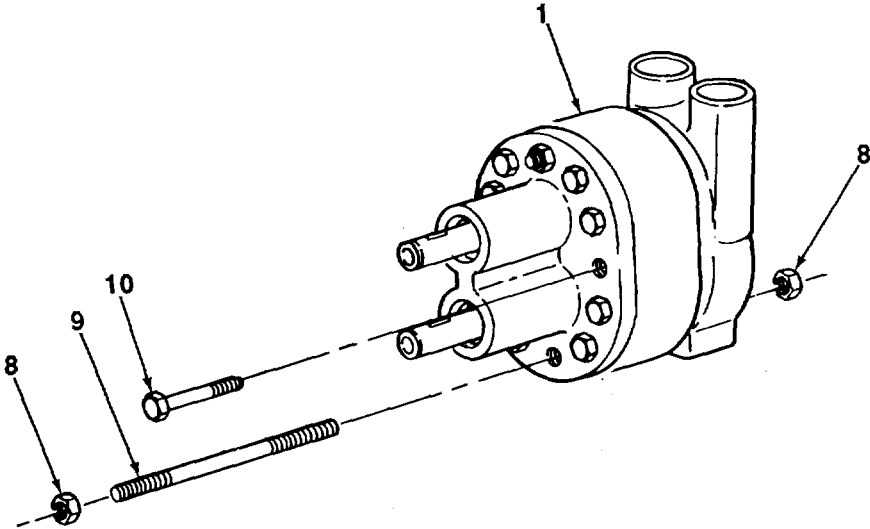

TA704236

17-2. HYDRAULIC ROTARY PUMP MAINTENANCE (Con't).**e. INSTALLATION**

1. Install woodruff key (7) to gearshaft (6).
2. Install spacer (4) and hydraulic pump (1) to subframe bracket (2) with bolt (3).
3. Install two bolts (5).

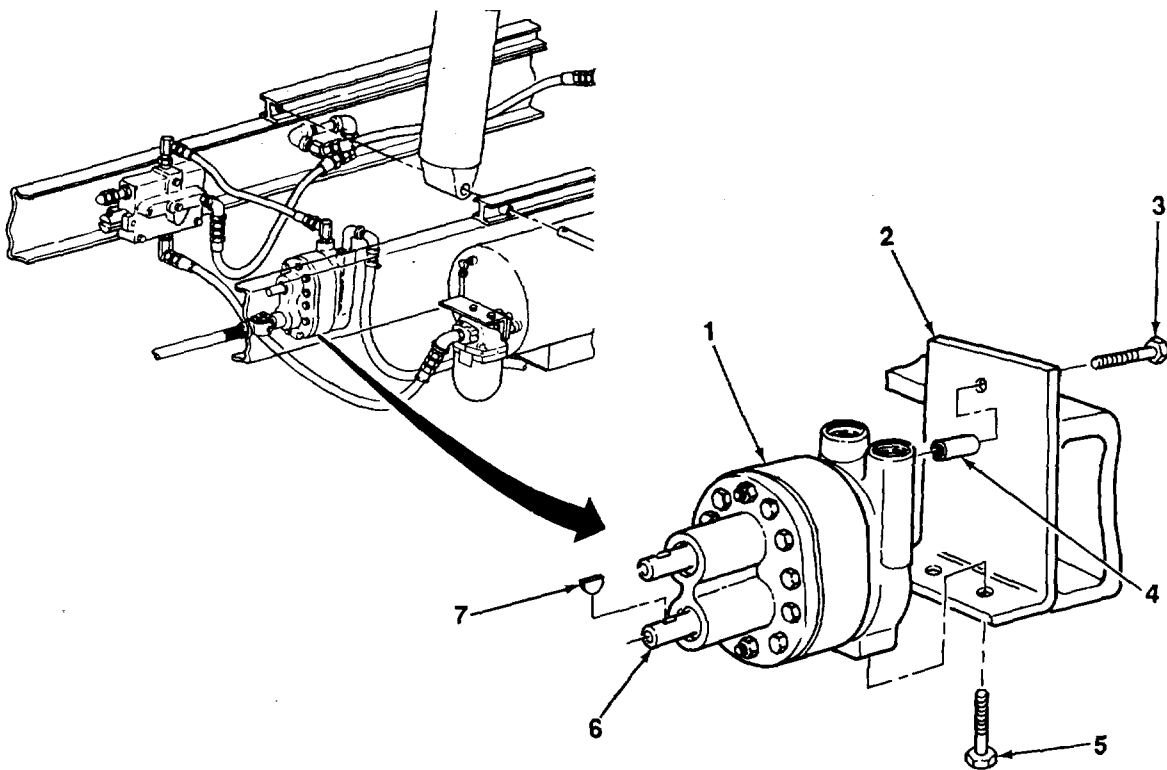
**FOLLOW-ON TASKS:**

- Install power take-off output shaft (see paragraph 16-4).
- Connect reservoir-to-pump suction hose and fittings (see TM 5-3805-254-20).
- Connect pump-to-valve pressure hose and fittings (see TM 5-3805-254-20).

TA704237

17-3. HYDRAULIC PUMP CONTROL VALVE MAINTENANCE.

This Task Covers:

- | | |
|----------------------------|-----------------|
| a. Removal | d. Assembly |
| b. Disassembly | e. Installation |
| c. Cleaning and Inspection | |

Initial Setup:

Equipment Conditions:

- Dump body control lever and linkage disconnected (see TM 5-3805-254-20).
- Valve-to-reservoir return hose and fittings disconnected (see TM 5-3805-254-20).
- Valve-to-cylinder pressure hose and fittings disconnected (see TM 5-3805-254-20).
- Pump-to-valve pressure hose and fittings disconnected (see TM 5-3805-254-20).

Tools/Test Equipment:

- General mechanic's tool kit

Materials/Parts:

- Lubricating oil (Item 14, Appendix B)
 - Dry cleaning solvent (Item 23, Appendix B)
 - One nylon seal
 - Two copper washers
 - Three lockwashers
 - Four preformed packings
- **General Safety Instructions:**
- Dry cleaning solvent is flammable and must not be used near open flame. Use only in a well-ventilated area.

a. REMOVAL

1. Remove two nuts (7), lockwashers (6), washers (5), and bolts (3) holding control valve (1) to subframe bracket (4). Discard lockwashers.
2. Remove bolt (2) and control valve (1) from subframe bracket (4).

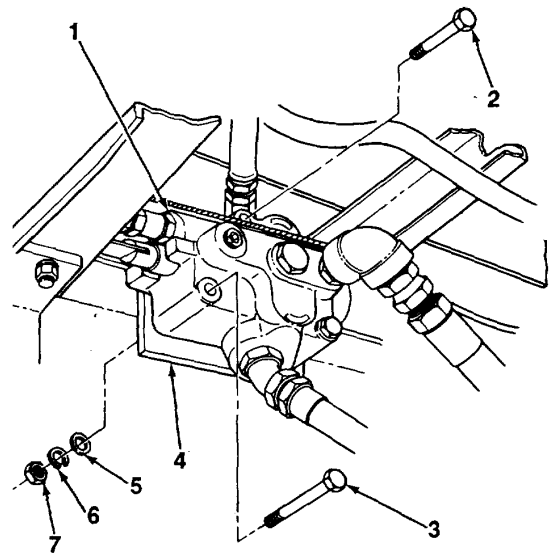

TA704238

17-3. HYDRAULIC PUMP CONTROL VALVE MAINTENANCE (Con't).

b. DISASSEMBLY

- 1. Remove plug (13), preformed packing (12), spring (11), and spring seat (10) from control valve housing (9). Discard preformed packing.
- 2. Remove pipe plug (14).
- 3. Remove valve (8) assembly.

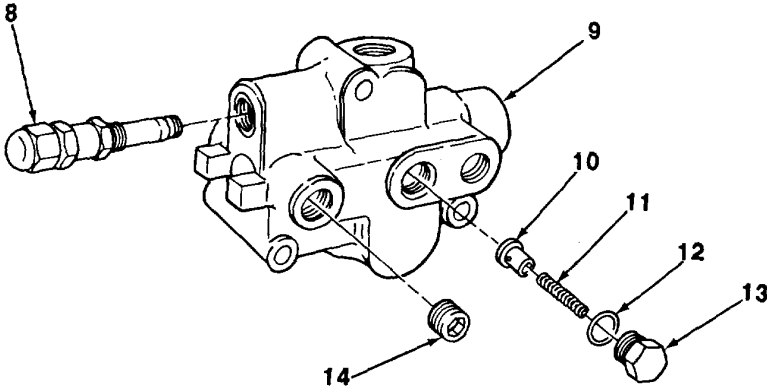

NOTE

Perform steps 4 through 10 to disassemble valve assembly.

- 4. Remove cap (15), nut (17), and two copper washers (16) from valve (8). Discard copper washers.
- 5. Remove preformed packing (25), nylon seal (24), and preformed packing (23). Discard preformed packings and nylon seal.
- 6. Note position of plunger (18) in valve (8) and remove plunger from valve.
- 7. Remove spring (19), spring plunger (20), preformed packing (21), and ball (22). Discard preformed packing.

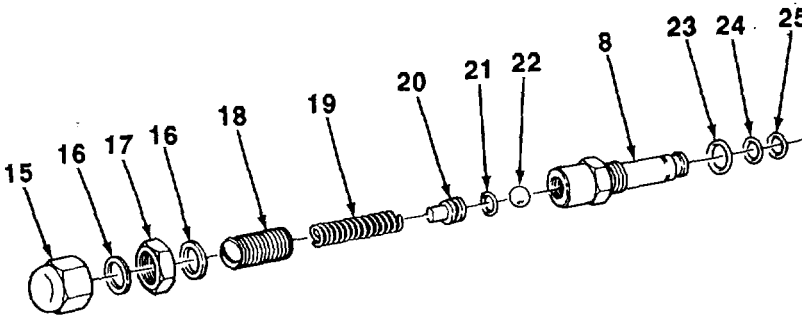

TA704239

17-3. HYDRAULIC PUMP CONTROL VALVE MAINTENANCE (Con't).

- 8. Pry diaphragm holder (30) from control valve housing (9).
- 9. Remove diaphragm (29) from diaphragm holder (30).
- 10. Remove retaining ring (28), washer (27), and valve (26) assembly from control valve housing (9).

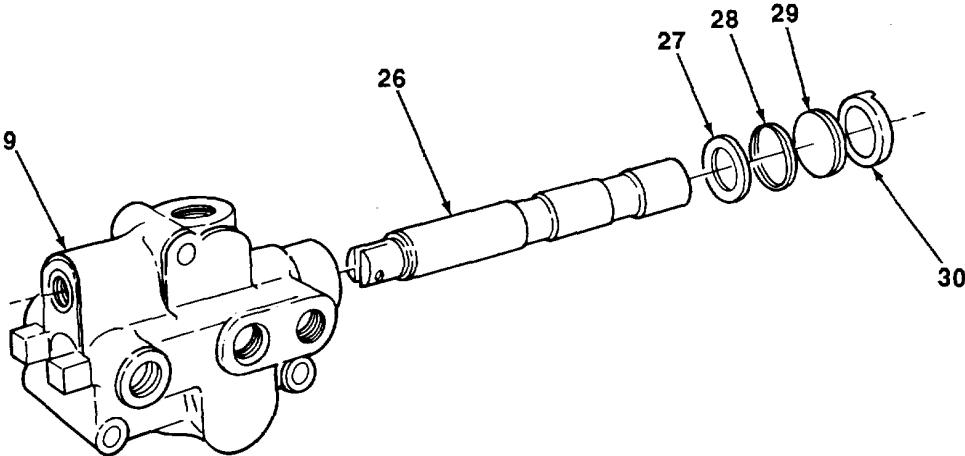

WARNING

Components are under spring pressure. Use care when removing screw to avoid injury.

NOTE

Perform step 11 to disassemble valve assembly.

- 11. Remove screw (35), lockwasher (34), spacer (33), two spring retainers (31), and spring (32) from end of valve (26). Discard lockwasher.

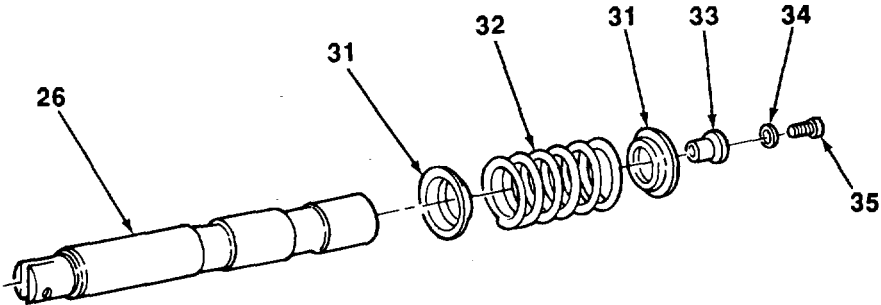

17-3. HYDRAULIC PUMP CONTROL VALVE MAINTENANCE (Con't).

c. CLEANING AND INSPECTION I**WARNING**

Dry cleaning solvent, P-D-680, is toxic and flammable. Always wear protective goggles and gloves, and use only in a well-ventilated area. Avoid contact with skin, eyes, and clothes, and DO NOT breathe vapors. DO NOT use near open flame or excessive heat. The solvent's flash point is 100°F-138°F (38°C-59°C). If you become dizzy while using cleaning solvent, immediately get fresh air and medical help. If solvent contacts eyes, immediately wash your eyes and get medical aid.

1. Clean metal parts with dry cleaning solvent.
2. Inspect metal parts for cracks, breaks, wear, and other damage. Replace if damaged.
3. Inspect bores of control valve for scratches and other damage.
4. Inspect for broken or deformed springs. Replace if damaged.

d. ASSEMBLY**NOTE**

Perform step 1 to assemble valve assembly.

1. Install spring (32), two spring retainers (31), and spacer (33) to end of valve (26) with new lockwasher (34) and screw (35).

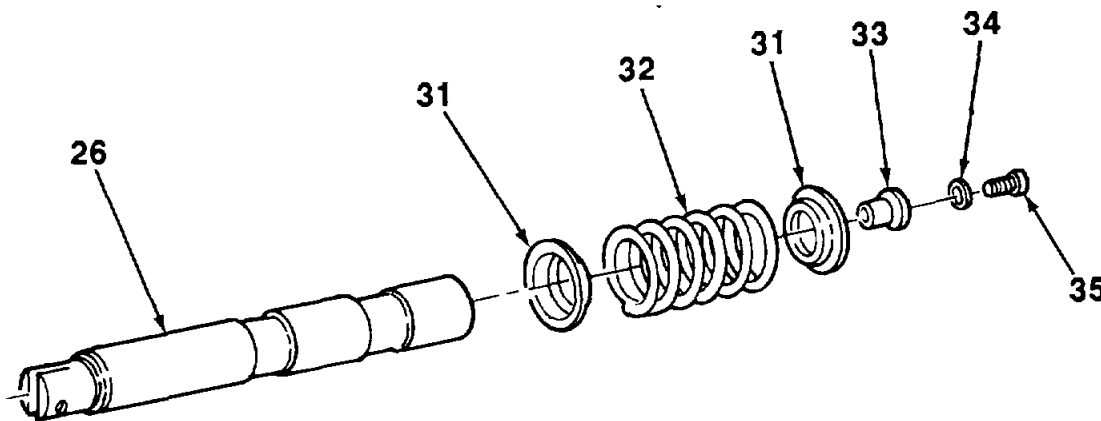

TA704241

17-3. HYDRAULIC PUMP CONTROL VALVE MAINTENANCE (Con't).

- 2. Install valve (26) assembly and washer (27) to control valve housing (9) with retaining ring (28).
- 3. Install diaphragm (29) to diaphragm holder (30).
- 4. Press diaphragm holder (30) into control valve housing (9).

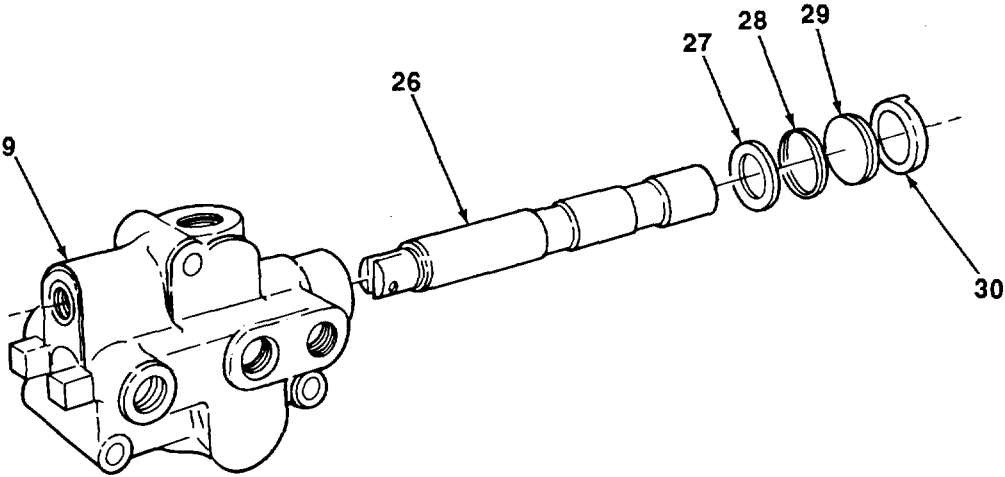

NOTE

Perform steps 5 through 8 to assemble valve assembly.

- 5. Install ball (22), new preformed packing (21), spring plunger (20), and spring (19) into valve (8).
- 6. Install plunger (18).
- 7. Install new preformed packing (23), new nylon seal (24), and new preformed packing (25).
- 8. Install two new copper washers (16), nut (17), and cap (15).

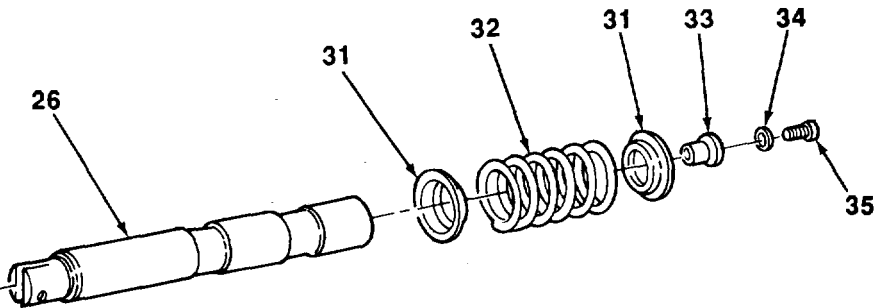

17-3. HYDRAULIC PUMP CONTROL VALVE MAINTENANCE (Con't).

9. Install valve (8) assembly to control valve housing (9).
10. Install pipe plug (14).
11. Install spring seat (10), spring (11), new preformed packing (12), and plug (13).

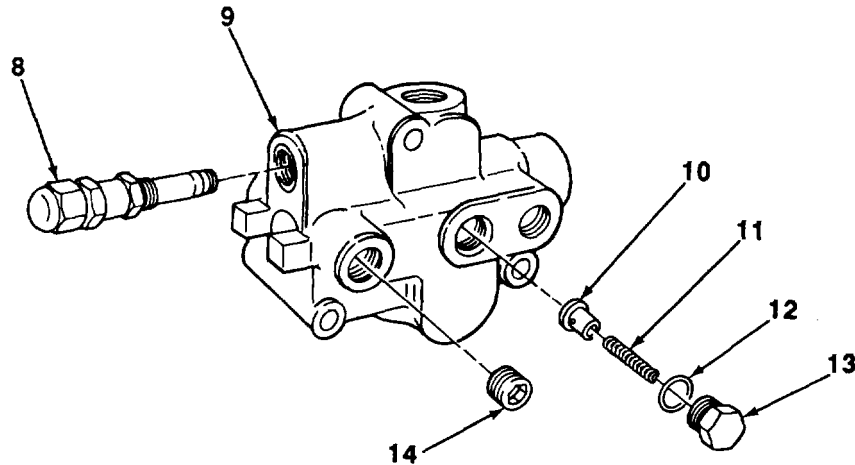
**e. INSTALLATION**

1. Install control valve (1) to subframe bracket (4) with bolt (2).
2. Install two bolts (3), washers (5), new lockwashers (6), and nuts (7).

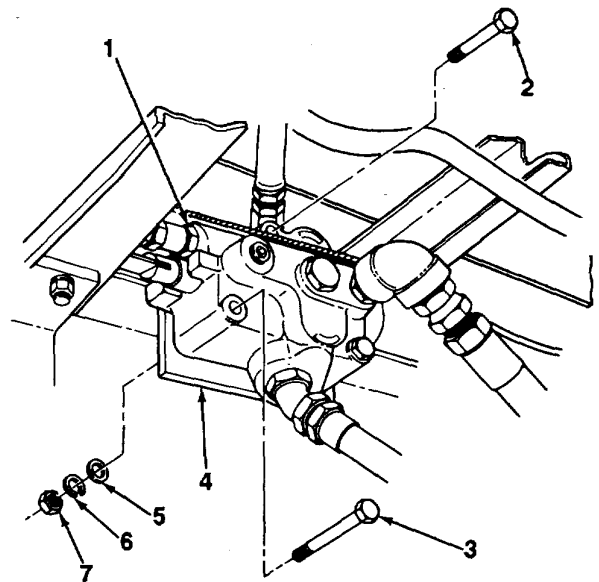
**FOLLOW-ON TASKS:**

- Connect pump-to-valve pressure hose and fittings (see TM 5-3805-254-20).
- Connect valve-to-reservoir return hose and fittings (see TM 5-3805-254-20).
- Connect valve-to-cylinder pressure hose and fittings (see TM 5-3805-254-20).
- Connect dump body control lever and linkage (see TM 5-3805-254-20).

TA704243

17-4. HYDRAULIC OIL RESERVOIR REPLACEMENT.

This Task Covers:

- a. Removal
- b. Cleaning and Inspection
- c. Installation

Initial Setup:

Equipment Conditions:

- Reservoir-to-pump suction hose and fittings disconnected (see TM 5-3805-254-20).
- Hydraulic filter and housing removed (see TM 5-3805-254-20).

Materials/Parts:

- Dry cleaning solvent (Item 23, Appendix B)
- Two lockwashers

Personnel Required: Two

Tools/Test Equipment:

- General mechanic's tool set
- Field automotive shop set

General Safety Instructions:

- Dry cleaning solvent is flammable and must not be used near open flame. Use only in a well-ventilated area.

a. REMOVAL

1. Position floor jack under hydraulic oil reservoir (2) and support hydraulic oil reservoir.

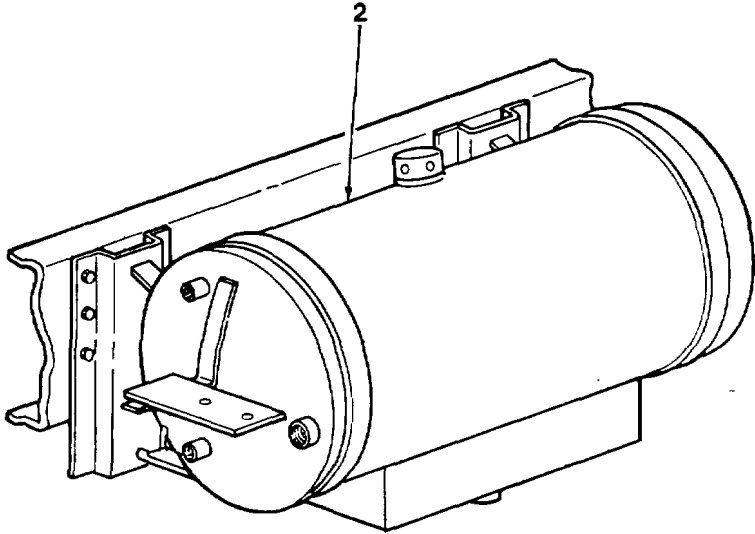
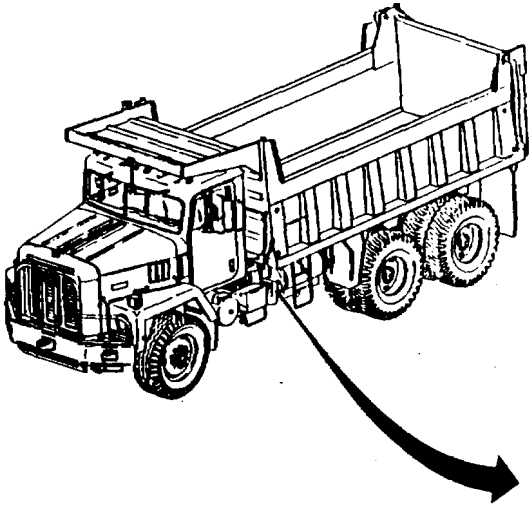

TA704244

17-4. HYDRAULIC OIL RESERVOIR REPLACEMENT (Con't).

- 2. Remove two nuts (5), lockwashers (4), and two straps (3) from hydraulic oil reservoir (2). Discard lockwashers.
- 3. Lower hydraulic oil reservoir (2) to ground.
- 4. Remove two nuts (6) and sight indicator (7) from end of hydraulic oil reservoir (2).
- 5. Remove two elbows (1) from hydraulic oil reservoir (2).

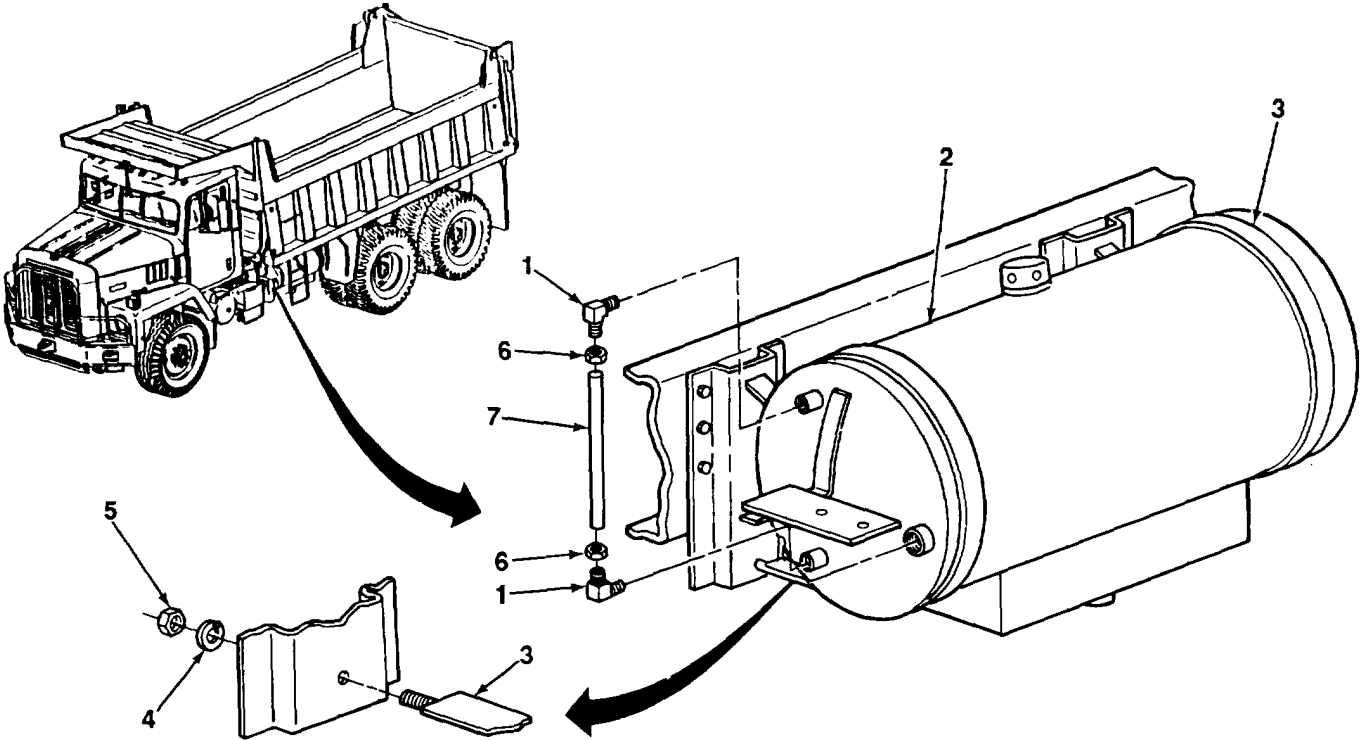

TA704245

17-4. HYDRAULIC OIL RESERVOIR REPLACEMENT (Con't).

b. CLEANING AND INSPECTION**WARNING**

Dry cleaning solvent, P-D-680, is toxic and flammable. Always wear protective goggles and gloves, and use only in a well-ventilated area. Avoid contact with skin, eyes, and clothes, and DO NOT breathe vapors. DO NOT use near open flame or excessive heat. The solvent's flash point is 100°F-138°F (38°C-59°C). If you become dizzy while using cleaning solvent, immediately get fresh air and medical help. If solvent contacts eyes, immediately wash your eyes and get medical aid.

1. Clean hydraulic oil reservoir and parts with dry cleaning solvent.
2. Inspect hydraulic oil reservoir for dents, cracks, holes, and corrosion. Replace if damaged.
3. Inspect sight indicator for cracks and clarity. Replace if defective.
4. Inspect other parts for cracks, corrosion, and other damage. Replace if damaged.

c. INSTALLATION I

1. Install two elbows (1) to end of hydraulic oil reservoir (2).
2. Install two nuts (6) and sight indicator (7).
3. Using floor jack, raise hydraulic oil reservoir (2) and move to vehicle.
4. Install hydraulic oil reservoir (2) with two straps (3), new lockwashers (4), and nuts (5).

FOLLOW-ON TASKS:

- Install hydraulic filter and housing (see TM 5-3805-254-20).
- Install reservoir-to-pump suction hose and fittings (see TM 5-3805-254-20).

**APPENDIX A
REFERENCES**

A-1. SCOPE.

This appendix lists all forms, field manuals, technical manuals, and other publications referenced in this manual and which apply to the Direct and General Support Maintenance of the dump truck.

A-2. PUBLICATION INDEX.

The following indexes should be consulted frequently for latest changes or revisions and for new publications relating to material covered in this technical manual.

Consolidated Index of Army Publications and Blank Forms	DA Pam 25-30
U.S. Army Equipment Index of Modification Work Orders	DA Pam 750-10

A-3. FORMS.

Refer to DA Pam 738-750, *The Army Maintenance Management System (TAMMS)*, for instructions on the use of maintenance forms.

Equipment Inspection and Maintenance Worksheet.....	DA 2404
Preventive Maintenance Schedule and Record	DD 314
Processing and Deprocessing Record for Shipment, Storage, and Issue of Vehicles and Spare Engines	DD 1397
Product Quality Deficiency Report.....	SF Form 368
Recommended Changes to Equipment Technical Publications	DA Form 2028-2
Recommended Changes to Publications and Blank Forms.....	DA Form 2028

A-4. FIELD MANUALS.

Camouflage	FM 5-20
First Aid for Soldiers	FM 21-11

A-5. TECHNICAL BULLETINS.

Color, Marking, and Camouflage Painting of Military Vehicles, Construction Equipment, and Materials Handling Equipment.....	TB 43-0209
Elimination of Combustibles from Interior of Metal or Plastic Gasoline and Diesel Fuel Tanks.....	TB 750-1047
Non-aeronautical Equipment Army Oil Analysis Program (AOAP)	TB 43-0210
Tactical Wheeled Vehicles: Repair of Frames	TB 9-2300-247-40

A-6. TECHNICAL MANUALS.

Cooling Systems: Tactical Vehicles	TM 750-254
Direct Support and General Support Maintenance (Including Repair Parts and Special Tools List) for Engine, Diesel NTC-290	TM 5-2815-241-34&P
Direct Support and General Support Maintenance Repair Parts and Special Tools Lists for Truck, Dump: 20-Ton, 6 x 4, ON-OFF Highway, 71,000 GVW, IHC MODEL F-5070 (CCE), (NSN 3805-00-192-7249)	TM 5-3805-254-34P
Inspection, Care, and Maintenance of Antifriction Bearings.....	TM 9-214
Materials Used for Cleaning, Preserving, Abrading, and Cementing Ordnance Materiel and Related Items Including Chemicals	TM 9-247
Operator's Manual for Truck, Dump: 20-Ton, 6 x 4, ON-OFF Highway, 71,000 GVW, IHC MODEL F-5070 (CCE), (NSN 3805-00-192-7249)	TM 5-3805-254-10
Operator's Manual for Welding Theory and Application.....	TM 9-237
Operator's, Unit, Direct Support, and General Support Maintenance Manual for Care, Maintenance, Repair, and Inspection of Pneumatic Tires and Inner Tubes	TM 9-2610-200-14
Operator's, Unit, Intermediate Direct Support, and Intermediate General Support Maintenance Manual for Lead-acid Storage Batteries	TM 9-6140-200-14
Organizational and Direct Support Maintenance Manual (Including RPSTL) for Army Oil Analysis Sampling Valves Army Oil Analysis Program, Nonaeronautical Equipment.....	TM 9-2300-422-23&P
Organizational Maintenance Manual for Truck, Dump: 20-Ton, 6 x 4, ON-OFF Highway, 71,000 GVW, IHC MODEL F-5070 (CCE), (NSN 3805-00-192-7249).....	TM 5-3805-254-20
Organizational Maintenance Repair Parts and Special Tools Lists for Truck, Dump: 20-Ton, 6 x 4, ON-OFF Highway, 71,000 GVW IHC MODEL F-5070 (CCE), (NSN 3805-00-192-7249)	TM 5-3805-254-20P
Painting Instructions for Army Materiel.....	TM 43-0139
Procedures for Destruction of Tank-automotive Equipment to Prevent Enemy Use	TM 750-244-6

A-7. OTHER PUBLICATIONS.

Truck, Dump (DED), 20-Ton, 6 x 4, ON-OFF Highway, 71,000 GVW IHC MODEL F-5070 (CCE), (NSN 3805-00-192-7249)	LO 5-3805-254-12
--	------------------

**APPENDIX B
EXPENDABLE/DURABLE SUPPLIES AND MATERIALS LIST**

Section I. INTRODUCTION

B-1. SCOPE.

This appendix lists expendable/durable supplies and materials you will need to operate and maintain the dump truck. This listing is for informational purposes only and is not authority to requisition the listed items. These items are authorized to you by CTA 50-970, *Expendable/Durable Items (Except Medical, Class V, Repair Parts, and Heraldic Items)*, or CTA 8-100, *Army Medical Department Expendable/Durable Items*.

B-2. EXPLANATION OF COLUMNS.

a. **Column (1) Item Number.** This number is assigned to the entry in the listing and is referenced in the "Initial Setup" of maintenance paragraphs or narrative instructions to identify the material needed (e.g., Dry cleaning solvent, Item 23, Appendix B).

b. **Column (2) - Level.** This column identifies the lowest level of maintenance that requires the listed item.

*C - Operator/Crew
O - Organizational Maintenance
F - Direct Support Maintenance
H - General Support Maintenance*

c. **Column (3) National Stock Number.** This is the National Stock Number assigned to the item. Use it to request or requisition the item.

d. **Column (4) Description.** Indicates the Federal item name and, if required, a description to identify the item. The last line for each item indicates the Commercial and Government Entity (CAGE) Code in parentheses followed by the part number, if applicable.

e. **Column (5) Unit of Measure (U/M).** Indicates the measure used in performing the actual maintenance function. This measure is expressed by a two-character alphabetical abbreviation (e.g., ea, in., pr). If the unit of measure differs from the unit of issue, requisition the lowest unit of issue that will satisfy your requirements.

Section II. EXPENDABLE/DURABLE SUPPLIES AND MATERIALS LIST

(1) ITEM NUMBER	(2) LEVEL	(3) NATIONAL STOCK NUMBER	(4) DESCRIPTION (CAGE) PART NUMBER	(5) U/M
1	O	8040-00-664-4318	ADHESIVE: General Purpose, Type II (81348) MMM-A-1617 1 Pint Can	pt
2	O	6850-00-181-7933 6850-00-181-7940	ANTIFREEZE: Ethylene Glycol, Inhibited, Heavy-duty, Single Package (81349) MIL-A-46153 5 Gallon Can 55 Gallon Drum	gl gl
3	O	7920-00-061-0038	BRUSH: Scrub (81348) H-B-1490	ea
4	O	5350-00-192-5051	CLOTH: Abrasive (58536) A-A1048 180 Grit - 50 Sheets	ea
5	O	5350-00-221-0872	CLOTH: Abrasive, Crocus (81348) P-C-458 50 Sheets	ea
6	O	7930-00-282-9699	DETERGENT: General Purpose, Liquid (81349) MIL-D-16791 1 Gallon Can	gl
7	O	9150-00-698-2382	FLUID: Hydraulic, Transmission, Dexron II (24617) MIL-L-2104 1 Quart Can	qt
8	O	3439-00-255-9935	FLUX: Soldering Rosin Base (81348) OF506 1 Pound Can	lb
9	O	9140-00-286-5296	FUEL OIL, DIESEL: DF-2, Regular (81348) VV-F-800 55 Gallon Drum, 16 Gage	gl
			B-2	

Section II. EXPENDABLE/DURABLE SUPPLIES AND MATERIALS LIST (Con't)

(1) ITEM NUMBER	(2) LEVEL	(3) NATIONAL STOCK NUMBER	(4) DESCRIPTION (CAGE) PART NUMBER	(5) U/M
10	O	9150-00-190-0904	GREASE: Automotive and Artillery (81349) MIL-G-10924 1 ¾ Pound Can	lb
11	O	9150-00-398-4170	GREASE: Special Purpose (07644) 25-10M5AO 1 Pound Can	lb
12	O	6810-00-238-8119	NAPTHA: Aliphatic (81348) TTN95 1 Gallon Can	gl
13	O	9150-00-270-0067	OIL: Lubricating, Gear (81348) VV-L-765 5 Gallon Can	gl
14	O	9150-00-186-6681 9150-00-186-9858 9150-00-189-6729	OIL: Lubricating, Internal Combustion Engine, Tactical Service, OE/HDO 30 (81349) MIL-L-2104 1 Quart Can 5 Gallon Can 55 Gallon Drum	qt gl gl
15	F	8010-00-652-3626	PASTE: Prussian Blue (81349) MIL-P-30501 1 Ounce Tube	oz
16	F	9150-00-250-0926	PETROLATUM: Technical (81348) VV-P-236	lb
17	C	7920-00-205-1711	RAG: Wiping Cotton and Cotton-synthetic, White (58536) A-A-531 50 Pound Bale	lb
18	F	4940-00-873-1730	RUBBER CEMENT (16720) V750-1	oz

Section II. EXPENDABLE/DURABLE SUPPLIES AND MATERIALS LIST (Con't)

(1) ITEM NUMBER	(2) LEVEL	(3) NATIONAL STOCK NUMBER	(4) DESCRIPTION (CAGE) PART NUMBER	(5) U/M
19	O	8040-00-833-9563	SEALANT: Adhesive Silicone, Rubber, RTV Type I, (80244) MIL-A-46106TYI 5 Ounce Package	oz
20	O	6810-00-264-6618	SODA: Bicarbonate, Technical, (81348) O-S-576 1 Pound Box	lb
21	O	3439-00-265-7102	SOLDER: Lead Alloy (81348) QQ-S-571 1 Pound Spool/Roll	lb
22	O	6850-00-935-1082	SOLVENT: Cleaning Compound (81349) MIL-C-81302 6 Ounce Bottle	oz
23	O	6850-00-664-5625 6850-00-281-1985 6850-00-285-8011	SOLVENT: Dry Cleaning Type II (81349) P-D-680 1 Quart Can 1 Gallon Can 55 Gallon Can	qt gal gal
24	O	5975-00-074-2072	STRAP: Tie-down, Electrical Components (96906) MS 3367-1-9 Box of 100	ea
25	O	9905-00-537-8954	TAG: Marker (81349) MIL-T-12755 50 each	ea

**Section II. EXPENDABLE/DURABLE SUPPLIES AND
MATERIALS LIST (Con't)**

(1) ITEM NUMBER	(2) LEVEL	(3) NATIONAL STOCK NUMBER	(4) DESCRIPTION (CAGE) PART NUMBER	(5) U/M
26	O	8030-00-067-7368	TAPE: Antiseizing ¼ Inch Width (71643) TEMPRTH 54 Feet Long	ft
		8030-00-889-3535	½ Inch Wide (76381) 4B 260 Inches Long	in.
27	O	5640-00-103-2254	TAPE: Duct, 2 Inch Width (07124) C-519 60 Yard Roll	yd
28	O	5970-00-198-8621	TAPE: Insulation, Electrical (81348) HH1510	ft
29	O	7510-00-473-9513	TAPE: Pressure Sensitive Adhesive, Masking, Flat, 2 Inch Width (81349) MIL-T-2397 60 Yard Roll	yd
30	O	5970-00-815-1295	TUBING: Heat Shrinkable (81349) MIL-1-23053/5	ft
31	O	6830-01-325-5586	TRICHLOROTRIFLUOROETHANE: Technical (22527) T-180 4 Liter Cylinder	li
32	O	4020-00-291-5901	TWINE: Fibrous, Cotton (String), 16-Ply (81348) T-T-871 375 Yard Roll	yd
33	O	8305-01-301-0191	WIPES: Lint-Free (28480) 92193W	ea
34	O	9505-00-596-0191	WIRE: Nonelectrical (81348) QQ-W-461 5 Pound Roll	lb
B-5/(B-6 Blank)				

APPENDIX C
ILLUSTRATED LIST OF MANUFACTURED ITEMS

Section I. INTRODUCTION

C-1. SCOPE.

- a. This appendix includes complete instructions for making items authorized to be manufactured or fabricated.
- b. All bulk materials needed for manufacture of an item are listed by National Stock Number (NSN), part number, or specification number in the manufacturing instructions. All dimensions given are in standard units.

Section II. Manufacturing Instructions

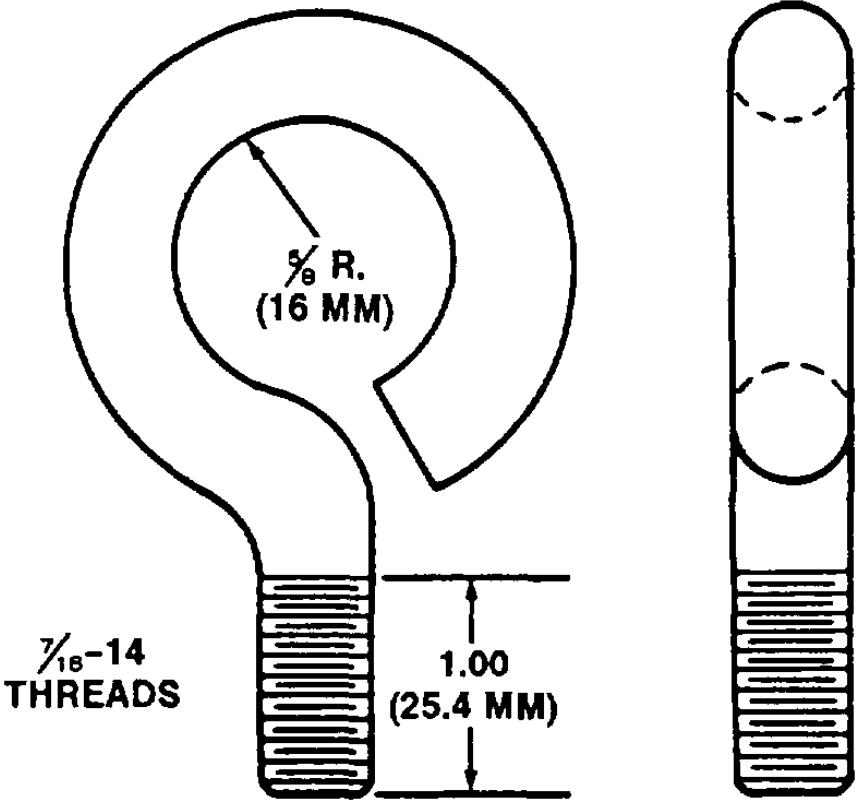

- 1. Fabricate from 1/2 X 6 in. cold rolled steel.
- 2. Thread size 7/16 X 14 X 1 in. long.
- 3. Heat unthreaded end and bend over 14 in. diameter rod.

**APPENDIX D
TORQUE LIMITS**

D-1. SCOPE.

This appendix lists standard torque values, as shown in Table D-1, and provides general information for applying torque. Special torque values and tightening sequences are indicated in the maintenance procedures for applicable components.





D-2. GENERAL.

- a. Always use the torque values listed in Table D-1 when the maintenance procedure does not give a specific torque value.
- b. Unless otherwise indicated, standard torque tolerance shall be $\pm 10\%$.
- c. Torque values listed are based on clean, dry threads. Reduce torque by 10% when engine oil is used as a lubricant. Reduce torque by 20% if new plated capscrews are used.
- d. Capscrews threaded into aluminum may require reductions in torque of 30% or more of Grade 5 capscrews torque. Capscrew threaded into aluminum must also attain two capscrew diameters of thread engagement.

CAUTION

If replacement capscrews are of higher grade than originally supplied, use torque specifications for the original. This will prevent equipment damage due to overtightening.

Table D-1. Torque Limits.

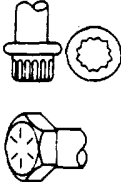
Current Usage	Much Used	Much Used	Used at Times	Used at Times
Quality of Material	Indeterminate	Minimum Commercial	Medium Commercial	Best Commercial
SAE Grade Number Capscrew Head Markings Manufacturer's marks may vary These are all SAE Grade 5 (3 line)	1 or 2  	5 	6 or 7 	8 
Capscrew Body Size Inches - Thread	Torque lb.-ft. (N•m)	Torque lb.-ft. (N•m)	Torque lb.-ft. (N•m)	Torque lb.-ft. (N•m)
$\frac{1}{4}$ 20 28	5 (7) 6 (8)	8 (11) 10 (14)	10 (14)	12 (16) 14 (19)
$\frac{5}{16}$ 18 24	11 (15) 13 (18)	17 (23) 19 (26)	19 (26)	24 (33) 27 (37)
$\frac{3}{8}$ 16 24	18 (24) 20 (27)	31 (42) 35 (47)	34 (46)	44 (60) 49 (66)
$\frac{7}{16}$ 14 20	28 (38) 30 (41)	49 (66) 55 (75)	55 (75)	70 (95) 78 (106)
$\frac{1}{2}$ 13 20	39 (53) 41 (56)	75 (102) 85 (115)	85 (115)	105 (142) 120 (163)
$\frac{5}{8}$ 12 18	51 (69) 55 (75)	110 (149) 120 (163)	120 (163)	155 (210) 170 (231)
$\frac{3}{4}$ 11 18	83 (113) 95 (129)	150 (203) 170 (231)	167 (226)	210 (285) 240 (325)
$\frac{7}{8}$ 10 16	105 (142) 115 (156)	270 (366) 295 (400)	280 (380)	375 (508) 420 (569)
1 9 14	160 (217) 175 (237)	395 (536) 435 (590)	440 (597)	605 (820) 675 (915)
1 8 14	235 (319) 250 (339)	590 (800) 660 (895)	660 (895)	910 (1234) 990 (1342)

TA704247

INDEX

Subject	Paragraph	Page
A		
Adapter Housing:		
Repair	6-39	6-182
Replacement	6-22	6-104
Air and Vacuum Shift.....	16-2	16-5
Air Compressor:		
Governor	10-2	10-7
Repair	10-3	10-8
Air Intake Duct.....	15-12	15-31
Air Shift Chamber, Power Divider Differential	9-3	9-33
Air Spring, Driver's Seat	15-29	15-80
Antiseizing Tape	1-19	1-8
Arms, Steering.....	12-5	12-25
Army Materiel, Destruction of, Prevent Enemy Use	1-3	1-1
Auxiliary Transmission:		
Linkage	6-4	6-33
Repair	6-2	6-7
Replacement.....	6-1	6-2
Top Cover	6-3	6-28
Axle:		
Forward-rear	8-3	8-4
Front.....	8-1	8-1
Power Differential Lock, Rear	9-4	9-37
Rear-rear.....	8-4	8-9
Skid Plate		
Forward-rear.....	8-2	8-3
Rear-rear	8-2	8-3
B		
Beams, Equalizer	13-1	13-1
Bench Check, Generator.....	5-1	5-1
Bleed Steering System.....	12-4	12-22

INDEX

Subject	Paragraph	Page
Body:		
Chassis Wiring Harness	5-6	5-38
Dump	15-36	15-106
Subframe	14-4	14-7
Bogle:		
Brackets	14-9	14-17
Crossmember	14-9	14-17
Bracket:		
Bogle	14-9	14-17
Cab Crossmember	14-9	14-16
Engine	14-6	14-11
Heater	15-33	15-97
Brake Spider, Front	10-1	10-1
Brake, Jacobs Exhaust, Wiring Harness	5-8	5-39
Brakedrum	11-1	11-1
Bumper 14-2	14-3	14-3

C

Cab:		
Assembly	15-4	15-13
Crossmember Brackets	14-8	14-16
Door:		
Glass, Window Regulator	15-15	15-38
Handles	15-14	15-36
Opening Weatherseal	15-8	15-26
Panels	15-13	15-32
Replacement	15-16	15-42
Rear:		
Glass	15-26	15-68
Trim	15-5	15-21
Carrier, Low Planetary:		
Repair	6-38	6-179
Replacement	6-20	6-101

INDEX

Subject	Paragraph	Page
Center Support:		
Repair	6-41	6-201
Replacement	6-24	6-109
Channel	14-4	14-9
Check, Door	15-9	15-28
Cleaning, General Maintenance	1-12	1-5
Clutch:		
First	6-23	6-105
Forward:		
Repair	6-30	6-127
Replacement	6-16	6-94
Fourth:		
Repair	6-31	6-140
Replacement	6-17	6-96
Low	6-21	6-102
Second	6-26	6-114
Third	6-18	6-97
Coat Hook	15-6	15-24
Column, Steering	12-6	12-28
Compression Fittings	1-20	1-9
Compressor, Air:		
Governor	10-2	10-7
Repair	10-3	10-8
Control Valve:		
Hydraulic Pump	17-3	17-11
Power Take-off	16-5	16-18
Repair	16-34	6-151
Replacement	6-14	6-83
Control:		
Heater	15-34	15-101
Panel, Heater	15-34	15-101
Converter:		
Housing	6-15	6-86
Torque:		
Cooler	6-6	6-42
Replacement	6-11	6-72
Core, Heater	15-33	15-97

INDEX

Subject	Paragraph	Page
Cover:		
Engine	15-1	15-2
Radio Opening	15-20	15-51
Cowl Ventilator	15-11	15-30
Crossmember:		
Bogie	14-9	14-17
Brackets, Cab	14-8	14-16
Engine	14-6	14-11
Rear	14-11	14-20
Torque Rod	14-10	14-18
Cylinder, Dump Body Hydraulic Lift.....	17-1	17-1
 D 		
Data, Equipment.....	1-6	1-2
Destruction of Army Materiel to Prevent Enemy Use	1-3	1-1
Differential:		
Air Shift Chamber, Power Divider	9-3	9-33
Forward-rear	9-1	9-1
Interaxle	9-2	9-20
Lock, Rear Axle Power	9-4	9-37
Rear-rear.....	9-5	9-39
Door:		
Check.....	15-9	15-28
Glass, Cab	15-9	15-38
Handles, Cab	15-14	15-36
Opening Weatherseal, Cab	15-8	15-26
Panels, Cab	15-13	15-32
Replacement, Cab	15-16	15-42
View Glass, Right.....	15-17	15-44
Dovetail.....	15-10 15-29	
Drag Link	12-11	12-66
Driver's Seat:		
Air Spring	15-29	15-80
Repair	15-31	15-82
Shock Absorber	15-30	15-81

INDEX

Subject	Paragraph	Page
Drum, Brake	11-1	11-1
Duct, Air Intake	15-12	15-31
Dump Body:		
Hydraulic Lift Cylinder	17-1	17-1
Replacement	15-36	15-106
Dust Shield	10-1	10-1

E

Electrical Ground Points	1-17	1-7
End Play Adjustment, Starter Motor	5-4	5-32
Engine:		
Brackets	14-6	14-11
Cover	15-1	15-2
Crossmember	14-6	14-11
Mounts	3-3	3-12
Replacement	3-1	3-2
Wiring Harness	5-6	5-38
Equalizer Beams	13-1	13-1
Equipment:		
Data	1-6	1-2
Improvement Recommendations, Reporting	1-4	1-1

F

Fan:		
Hub, Radiator	4-7	4-38
Motor, Heater	15-32	15-93
Radiators	4-8	4-37
Fender	15-24	15-60
First Clutch	6-23	6-105
Fittings:		
Compression	1-20	1-9
Transmission, Cooler	6-5	6-39

INDEX

Subject	Paragraph	Page
Floorboards	15-3	15-7
Floormat	15-2	15-4
Fluid Disposal	1-22	1-10
Flywheel.....	6-10	6-64
Forward Clutch:		
Repair	6-30	6-127
Replacement.....	6-16	6-94
Forward-rear Axle:		
Replacement.....	8-3	8-4
Skid Plate.....	8-2	8-3
Forward-rear Differential	9-1	9-1
Fourth Clutch:		
Repair	6-31	6-140
Replacement.....	6-17	6-96
Frame:		
Reinforcement	14-7	14-14
Repair	14-12	14-21
Tie Tube.....	14-3	14-6
Front:		
Axle	8-1	8-1
Springs.....	13-2	13-7
Support:		
Repair.....	6-29	6-122
Replacement	6-15	6-86
Fuel Lines	3-2	3-8

G

Gear:		
Low Ring.....	6-21	6-102
Power Steering:		
Left:		
Repair.....	12-2	12-4
Replacement	12-1	12-1

INDEX

Subject	Paragraph	Page
Power Steering (Con't):		
Right:		
Repair	12-3	12-15
Replacement	12-3	12-15
Ring	6-23	6-105
Unit:		
Repair	6-40	6-186
Replacement	6-25	6-112
General Maintenance:		
Cleaning	1-12	1-5
Inspection Instructions	1-15	1-6
Lines	1-18	1-8
Lockwire	1-21	1-9
Preservation of Parts	1-13	1-6
Transmission	1-23	1-10
Tubes	1-20	1-9
Generator:		
Bench Check	5-1	5-1
Repair	5-1	5-1
Test	5-1	5-1
Glass:		
Cab Door	15-15	15-38
Cab Rear	15-26	15-68
Windshield	15-25	15-65
Governor:		
Air Compressor	10-2	10-7
Assembly	6-35	6-171
Grille Guard	14-1	14-1
Ground Points, Electrical	1-17	1-7
Guard, Grille	14-1	14-1
Gussets:		
Rear	14-11	14-20
Torque Rod	14-10	14-18

H

Handles, Cab Door	15-14	15-36
-------------------------	-------	-------

INDEX

Subject	Paragraph	Page
Harness, Wiring:		
Body and Chassis	5-6	5-38
Engine	5-6	5-38
Jacobs Exhaust Brake	5-8	5-39
Transmission	5-6	5-38
Headlining.....	15-23	15-58
Heater:		
Box.....	15-35	15-104
Control:		
Panel	15-34	15-101
Replacement	15-34	15-101
Core, Bracket	15-33	15-97
Fan Motor.....	15-32	15-93
Hinge, Cab.....	15-16	15-42
Hook, Coat	15-6	15-24
Hoses, Transmission Cooler	6-5	6-39
Housing:		
Adapter:		
Repair	6-39	6-182
Replacement	6-22	6-104
Converter	6-15	6-86
Output:		
Repair	6-37	6-173
Replacement	6-19	6-99
Transmission	6-27	6-117
Hub, Radiator Fan	4-7	4-38
Hydraulic:		
Lift Cylinder, Dump Body	17-1	17-1
Oil Reservoir	17-4	17-17
Pump:		
Control Valve	17-3	17-11
Steering.....	12-7	12-40
Rotary Pump.....	17-2	17-4
Input Shaft	6-16	6-94

INDEX

Subject	Paragraph	Page
Inserts	15-3	15-7
Inspection Instructions.....	1-15	1-6
Instrument Panel:		
Pad.....	15-21	15-52
Replacement.....	15-21	15-52
Intake Duct, Air.....	15-12	15-31
Interaxle Differential	9-2	9-20
 J 		
Jacobs Exhaust Brake Wiring Harness	5-8	5-39
Joint, Universal.....	7-1	7-1
 K 		
Knuckle, Steering	12-8	12-49
 L 		
Lines:		
Fuel.....	3-2	3-8
General Maintenance.....	1-18	1-8
Link, Drag	12-11	12-66
Linkage:		
Auxiliary Transmission.....	6-4	6-33
Tailgate	15-27	15-70
Location and Description of Major Components	1-5	1-2
Lockwire, General Maintenance.....	1-21	1-9
Low:		
Clutch.....	6-21	6-102

INDEX

Subject	Paragraph	Page
Low (Con't):		
Planetary Carrier:		
Repair	6-38	6-179
Replacement	6-20	6-101
Ring Gear.....	6-21	6-102
Shift Valve:		
Repair.....	6-33	6-149
Replacement	6-13	6-82
Trimmer Valve	6-32	6-147

M

Maintenance, General:		
Cleaning.....	1-12	1-5
Inspection Instructions	1-15	1-6
Lines	1-18	1-8
Lockwire.....	1-21	1-9
Preservation of Parts	1-13	1-6
Transmission	1-23	1-10
Tubes	1-20	1-9
Major Components, Location and Description	1-5	1-2
Modulator Valve, Transmission	6-7	6-51
Molding, Rear Window	15-7	15-25
Motor, Heater Fan	15-32	15-93
Mounts, Engine.....	3-3	3-12

O

Oil Pump:		
Repair	6-28	120
Replacement.....	6-15	6-86
Oil Reservoir, Hydraulic.....	17-4	17-17

INDEX

Subject	Paragraph	Page
Output Housing:		
Repair	6-37	6-173
Replacement.....	6-19	6-99
Output Shaft, Power Take-off.....	16-4	16-16
Overhaul Stand:		
Install Transmission	6-9	6-62
Remove Transmission	6-9	6-62
 P 		
Pad, Instrument Panel.....	15-21	15-52
Painting.....	1-14 1-6	
Panel:		
Cab Door.....	15-13	15-32
Instrument.....	15-22	15-54
Pad, Instrument.....	15-21	15-52
Parts:		
General Maintenance.....	1-18	1-8
Preservation.....	1-13	1-6
Tagging	1-16	1-7
Planetary Carrier, Low:		
Repair	6-38	6-179
Replacement.....	6-20	6-101
Power Divider Differential Air Shift Chamber	9-3	9-33
Power Steering Gear:		
Left:		
Repair.....	12-2	12-4
Replacement	12-1	12-1
Right:		
Repair.....	12-3	12-15
Replacement	12-1	12-1
Power Take-off:		
Control Valve	16-5	16-18
Output Shaft.....	16-4	16-16

INDEX

Subject	Paragraph	Page
Power Take-off (Con't):		
Repair	16-3	16-8
Replacement	16-1	16-1
Preservation of Parts	1-13	1-6
Propeller Shaft	7-1	7-1
Pump:		
Control Valve, Hydraulic	17-3	17-11
Hydraulic Rotary	17-2	17-4
Oil:		
Repair	6-28	6-8120
Replacement	6-15	6-86
Steering Hydraulic	12-7	12-40

R

Radiator:		
Fan:		
Hub	4-7	4-38
Replacement	4-6	4-37
Maintenance	4-4	4-18
Shell	4-3	4-12
Shroud	4-5	4-36
Shutter	4-1	4-1
Support	14-13	14-22
Radio Opening Cover	15-20	15-51
Rear:		
Axle Power Differential Lock	9-4	9-37
Crossmember	14-11	14-20
Gussets	14-11	14-20
Springs	13-3	13-13
Trim Cab	15-5	15-21
Rear-rear Axle:		
Replacement	8-4	8-9
Skid Plate	8-2	8-3
Rear-rear Differential	9-5	9-39
Release Lever, Tailgate	15-27	15-70

INDEX

Subject	Paragraph	Page
Reporting Equipment Improvement Recommendations	1-4	1-1
Right Door View Glass	15-17	15-44
Right Power Steering.....	12-1	12-1
Ring Gear:		
Low	6-21	6-102
Replacement.....	6-23	6-105
Rod, Torque:		
Crossmembers	14-10	14-18
Gussets.....	14-10	14-18
Replacement.....	13-4	13-20
Rotary Pump, Hydraulic.....	17-2 17-4	

S

Seat, Driver's:		
Air Spring	15-29	15-80
Repair	15-31	15-82
Shock Absorber	15-30	15-81
Second Clutch	6-26	6-114
Shaft:		
Input	6-16	6-94
Power Take-off Output.....	16-4	16-16
Propeller.....	7-1	7-1
Shell, Radiator	4-3	4-12
Shield, Dust	10-1	10-1
Shift, Air and Vacuum.....	16-2	16-5
Shift Valve, Low:		
Repair	6-33	6-149
Replacement.....	6-13	6-82
Shock Absorber, Driver's Seat	15-30	15-81
Shroud, Radiator	4-5	4-36
Shutter, Radiator	4-1	4-1
Shutterstat	4-2	4-10

INDEX

Subject	Paragraph	Page
Skid Plate:		
Forward-rear axle.....	8-2	8-3
Rear-rear Axle.....	8-2	8-3
Solenoid, Starter Motor.....	5-5	5-35
Spider, Front Brake	10-1	10-1
Springs:		
Front.....	13-2	13-7
Rear	13-3	13-13
Starter Motor:		
End Play Adjustment.....	5-4	5-32
Repair	5-3	5-14
Solenoid.....	5-5	5-35
Test	5-2	511
Steering:		
Arms.....	12-5	12-25
Column.....	12-6	12-28
Hydraulic Pump.....	12-7	12-40
Knuckle	12-8	12-49
Wheel.....	12-9	12-58
Steering Gear, Power:		
Left:		
Repair.....	12-2	12-4
Replacement	12-1	12-1
Right:		
Repair.....	12-3	12-15
Replacement	12-1	12-1
Steering System:		
Adjust	12-4	12-22
Bleed.....	12-4	12-22
Subframe, Body.....	14-4	14-7
Sunvisor.....	15-19	15-49
Support:		
Center:		
Repair	6-41	6-201
Replacement.....	6-24	6-109

INDEX

Subject	Paragraph	Page
Support (Con't):		
Front:		
Repair	6-29	6-122
Replacement	6-15	6-86
Radiator	14-13	14-22
 T 		
Tagging.....	1-16	1-7
Tailgate:		
Release Lever, Linkage	15-27	15-70
Replacement	15-28	15-77
Take-off, Power:		
Control Valve	16-5	16-18
Output Shaft.....	16-4	16-16
Repair	16-3	16-8
Replacement.....	16-1	16-1
Tape, Antiseizing	1-19	1-8
Test:		
Generator.....	5-1	5-1
Starter Motor	5-2	5-11
Third Clutch	6-18	6-97
Tie-rod 12-10	12-61	
Tie Tube, Frame	14-3	14-6
Tire	11-2	11-4
Top Cover, Auxiliary Transmission.....	6-3	6-28
Torque Converter:		
Cooler	6-6	6-42
Replacement.....	6-11	6-72
Torque Rod:		
Crossmembers	14-10	14-18
Gussets.....	14-10	14-18
Replacement.....	13-4	13-20

INDEX

Subject	Paragraph	Page
Transmission:		
Auxiliary:		
Linkage	6-4	6-33
Repair	6-2	6-7
Replacement	6-1	6-2
Top Cover	6-3	6-28
Cooler Hoses	6-5	6-39
Fittings	6-5	6-39
General Maintenance	1-23	1-10
Housing	6-27	6-117
Install on Overhead Stand	6-9	6-62
Modulator Valve	6-7	6-51
Remove from Overhead Stand	6-9	6-62
Replacement	6-8	6-58
Wiring Harness	5-6	5-38
Trim, Cab Rear	15-5	15-21
Trimmer Valve, Low	16-32	6-147
Troubleshooting, Symptom Index	2-3	2-2
Tubes, General Maintenance	1-20	1-9

U

Unit, Gear:		
Repair	6-40	6-186
Replacement	6-25	6-112
Universal Joint	7-1	7-1

V

Vacuum and Air Shift	16-2	16-5
----------------------------	------	------

INDEX

Subject	Paragraph	Page
Valve:		
Control:		
Hydraulic Pump	17-3	17-11
Power Take-off	16-5	16-18
Repair	6-34	6-151
Replacement	6-14	6-83
Low Shift:		
Repair	6-33	6-149
Replacement	6-13	6-82
Low Trimmer	6-32	6-147
Modulator, Transmission	6-7	6-51
Trimmer, Replacement	6-12	6-80
Vent Window	15-18	15-47
Ventilator, Cowl	15-11	15-30
View Glass, Right Door	15-17	15-44

W

Weatherseal, Cab Door Opening	15-8	15-26
Wheel, Steering	12-9	12-58
Window:		
Molding, Rear	15-7	15-25
Regulator	15-15	15-38
Vent	15-18	15-47
Windshield Glass	15-25	15-65
Wiring:		
Diagram	5-7	5-39
Harness:		
Body and Chassis	5-6	5-38
Engine	5-6	5-38
Jacobs Exhaust Brake	5-8	5-39
Transmission	5-6	5-38
Work Safety	1-11	1-5

TM 5-3805-254-34

By Order of the Secretary of the Army:

GORDON R. SULLIVAN
General, United States Army
Chief of Staff

Official:

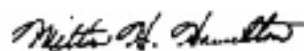

MILTON H. HAMILTON
Administrative Assistant to the
Secretary of the Army
04081

Distribution:

To be distributed in accordance with DA Form 12-25-E (Block 6046) requirements for TM5-3805-2544.

*U.S. GOVERNMENT PRINTING OFFICE 1 9 9 3 -7- 017/ 8 01 4 6

THE METRIC SYSTEM AND EQUIVALENTS

LINEAR MEASURE

- 1 Centimeter = 10 Millimeters = 0.01 Meters = 0.3937 Inches
- 1 Meter = 100 Centimeters = 1,000 Millimeters = 39.37 Inches
- 1 Kilometer = 1,000 Meters = 0.621 Miles

SQUARE MEASURE

- 1 Sq Centimeter = 100 Sq Millimeters = 0.155 Sq Inches
- 1 Sq Meter = 10,000 Sq Centimeters = 10.76 Sq Feet
- 1 Sq Kilometer = 1,000,000 Sq Meters = 0.386 Sq Miles

CUBIC MEASURE

- 1 Cu Centimeter = 1,000 Cu Millimeters = 0.06 Cu Inches
- 1 Cu Meter = 1,000,000 Cu Centimeters = 35.31 Cu Feet

LIQUID MEASURE

- 1 Milliliter = 0.001 Liters = 0.0338 Fluid Ounces
- 1 Liter = 1,000 Milliliters = 33.82 Fluid Ounces

TEMPERATURE

- $5/9 (^{\circ}\text{F} - 32) = ^{\circ}\text{C}$
- 212° Fahrenheit is equivalent to 100° Celsius
- 90° Fahrenheit is equivalent to 32.2° Celsius
- 32° Fahrenheit is equivalent to 0° Celsius
- $9/5 \text{ C}^{\circ} + 32 = \text{F}^{\circ}$

WEIGHTS

- 1 Gram = 0.001 Kilograms = 1,000 Milligrams = 0.035 Ounces
- 1 Kilogram = 1,000 Grams = 2.2 lb.
- 1 Metric Ton = 1,000 Kilograms = 1 Megagram = 1.1 Short Tons

APPROXIMATE CONVERSION FACTORS

TO CHANGE	TO	MULTIPLY BY
Inches	Centimeters	2.540
Feet	Meters	0.305
Yards	Meters	0.914
Miles	Kilometers	1.609
Square Inches	Square Centimeters	6.451
Square Feet	Square Meters	0.093
Square Yards	Square Meters	0.836
Square Miles	Square Kilometers	2.590
Acres	Square Hectometers	0.405
Cubic Feet	Cubic Meters	0.028
Cubic Yards	Cubic Meters	0.765
Fluid Ounces	Milliliters	29.573
Pints	Liters	0.473
Quarts	Liters	0.946
Gallons	Liters	3.785
Ounces	Grams	28.349
Pounds	Kilograms	0.454
Short Tons	Metric Tons	0.907
Pound-Feet	Newton-Meters	1.356
Pounds Per Square Inch	Kilopascals	6.895
Miles Per Gallon	Kilometers Per Liter	0.425
Miles Per Hour	Kilometers Per Hour	1.609
TO CHANGE	TO	MULTIPLY BY
Centimeters	Inches	0.394
Meters	Feet	3.280
Meters	Yards	1.094
Kilometers	Miles	0.621
Square Centimeters	Square Inches	0.155
Square Meters	Square Feet	10.764
Square Meters	Square Yards	1.196
Square Kilometers	Square Miles	0.386
Square Hectometers	Acres	2.471
Cubic Meters	Cubic Feet	35.315
Cubic Meters	Cubic Yards	1.308
Milliliters	Fluid Ounces	0.034
Liters	Pints	2.113
Liters	Quarts	1.057
Liters	Gallons	0.264
Grams	Ounces	0.035
Kilograms	Pounds	2.205
Metric Tons	Short Tons	1.102
Newton-Meters	Pound-Feet	0.738
Kilopascals	Pounds Per Square Inch	0.145
Kilometers Per Liter	Miles Per Gallon	2.354
Kilometers Per Hour	Miles Per Hour	0.621

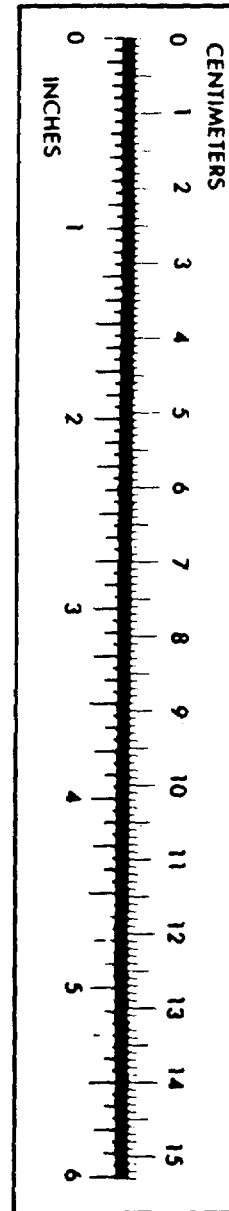

RECOMMENDED CHANGES TO EQUIPMENT TECHNICAL PUBLICATIONS



THEN... JOT DOWN THE DOPE ABOUT IT ON THIS FORM, CAREFULLY TEAR IT OUT, FOLD IT AND DROP IT IN THE MAIL!

SOMETHING WRONG WITH THIS PUBLICATION?

FROM: (PRINT YOUR UNIT'S COMPLETE ADDRESS)

DATE SENT

PUBLICATION NUMBER

PUBLICATION DATE

PUBLICATION TITLE

BE EXACT... PIN-POINT WHERE IT IS				IN THIS SPACE TELL WHAT IS WRONG AND WHAT SHOULD BE DONE ABOUT IT:
PAGE NO.	PARA-GRAPH	FIGURE NO.	TABLE NO.	

PRINTED NAME, GRADE OR TITLE, AND TELEPHONE NUMBER

SIGN HERE:

TEAR ALONG PERFORATED LINE

